

B|W Controls

Induction Relays

THE SERIES 1500 INDUCTION RELAY WITH FIELD CONVERTIBLE CONTACTS PROVIDES A VERSATILE AND RELIABLE LIQUID LEVEL CONTROL

APPLICATION

As the pioneer producer of electrode-activated float-less level control systems, we acquired broad, practical experience in developing and manufacturing equipment to meet the requirements of a wide range of liquid level applications.

The Series 1500 Induction Relays provide versatile and economical means of controlling many processing and production functions from remote locations with the safety inherent in a low energy sensing circuit that is isolated from the AC power source.

Installed near pumps, motors or other operating equipment, the Series 1500 Induction Relay permits use of low-cost light gauge wires for the control circuit to level sensing electrodes. Relays with low voltage secondary coils provide remote control up to 36,000 feet from contact type pilot devices.

Available as open chassis units or furnished factory mounted in a choice of standard or special enclosures, these relays are connected to a constant source of alternating current. When properly installed, they will draw a maximum of 9 volt-amperes regardless of the line or electrode circuit voltage.

FEATURES

The 1500 Series Induction Relay, not only retains the high quality and durability of the Series 1100 Induction Relay, but also provides these important features.

- Available with 1, 2 or 3 isolated double break contacts
- Contacts can be added in the field
- Contact arrangement can be added or changed in the field from N.O. to N.C. or N.C. to N.O.
- All terminals completely accessible and have #8 pan head screws with captivated wire clamp
- Z type rectified relay module can be easily attached for D.C. sensing
- All contacts rated 25 AMP at 120V or 240VAC

CONTACT RATINGS

25 Amp Resistive at 120, 240, or 480 VAC
 1 HP Single Phase at 120 or 240 VAC
 Heavy Duty Pilot 120 to 600 VAC
 2 Amp Resistive at 120 VDC
 10 Amp Resistive at 48 VDC

CIRCUIT VERSATILITY

The Series 1500 Induction Relay can have contacts easily added and/or changed from N.O. to N.C. or N.C. to N.O.

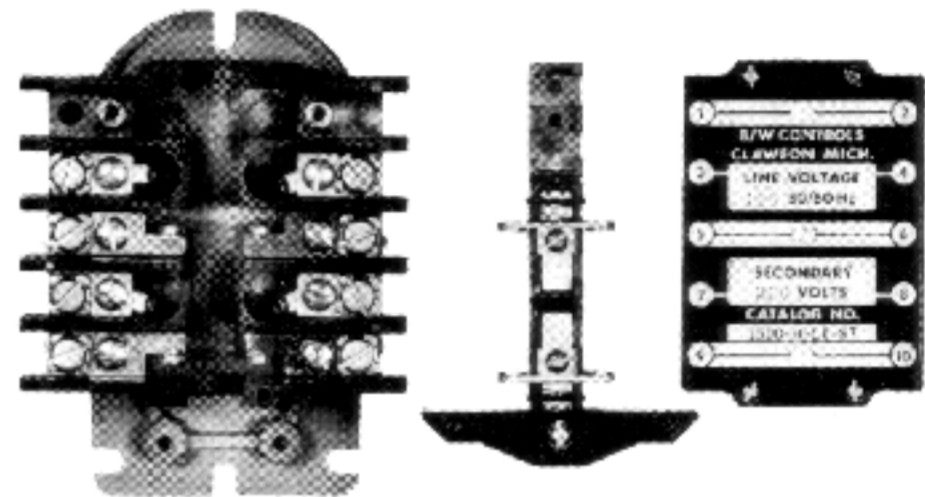

Remove cover plate and armature

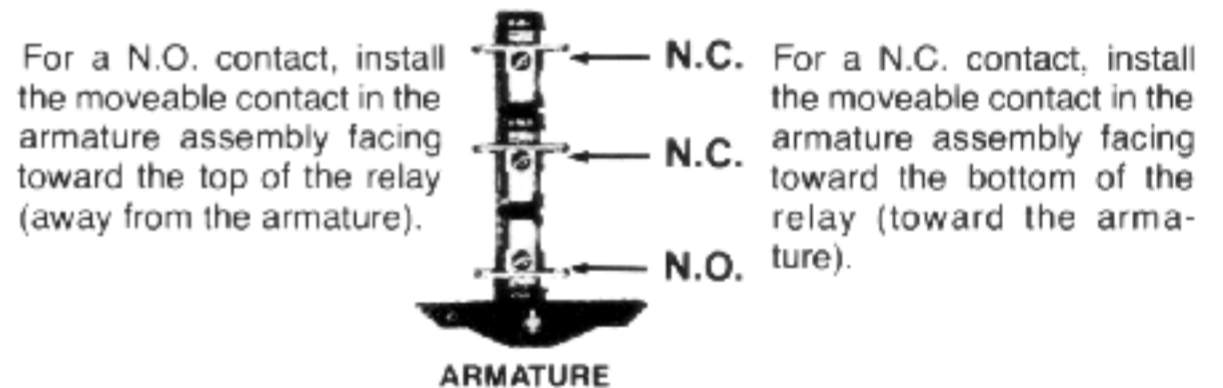

ARMATURE

N.O. CONTACT

N.C. CONTACT



For a N.O. contact, install the stationary contacts facing toward the bottom of the relay (toward the armature).

For a N.C. contact, install the stationary contacts facing toward the top of the relay (away from the armature).

Replacement Contact #15-00001

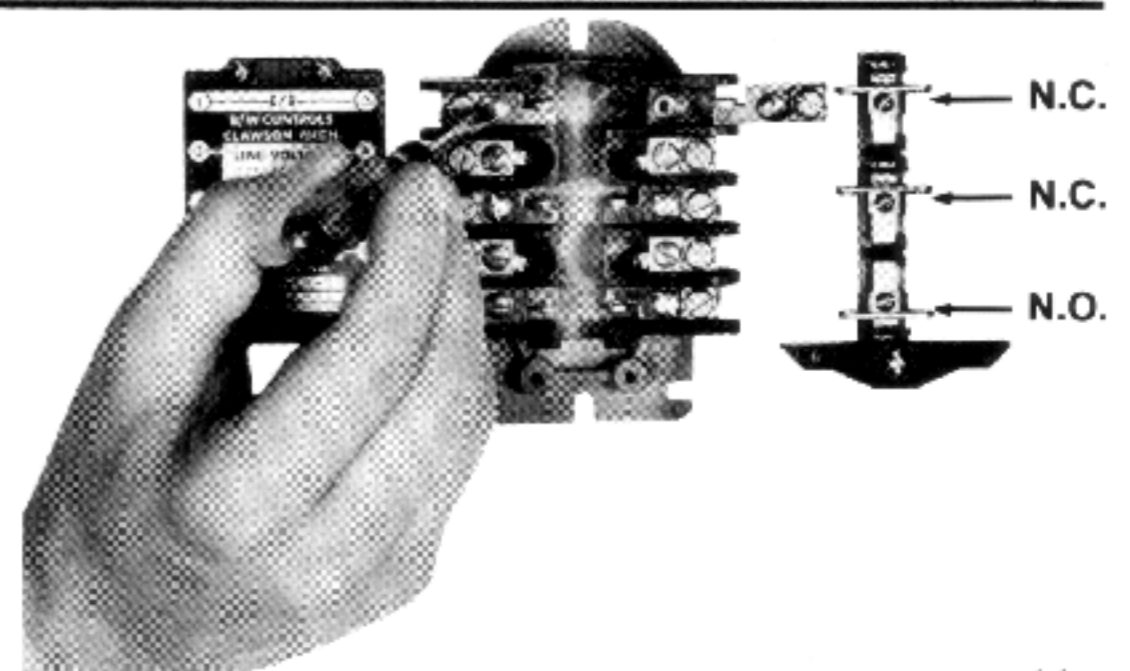

PRINCIPLE OF OPERATION

A floatless liquid level control system consists of a relay of the proper type, a holder designed to support one or more electrodes or probes in the liquid container, and the corrosion resistant electrodes themselves. Inasmuch as all BIW induction relays are quite similar — differing only in contact arrangement, the following description of how a 1500-C Relay functions on a pump down control application will serve to explain the design, construction, and operating principles for the entire line.

As shown in diagrams below, the laminated core of the relay is **A** shaped. The primary coil is assembled to the upper bar of the core, and the secondary coil for the electrode is placed on the lower bar. An armature located below the legs of the **A** core is connected to an insulated arm carrying the movable contacts. When the armature is raised, these contacts close or open the motor and electrode circuits, depending upon whether the contacts are normally open or closed. (Contacts shown normally open in this example.)

When a source of alternating current is connected to the primary coil at terminals 3 and 4, the primary coil sets up a magnetic flux which — following the lines of least resistance — circulates through the shortest path. As shown in Figure 1, this is through the lower bar of the laminated core on which the secondary coil is mounted. This magnetic flux induces a voltage in the secondary or electrode circuit coil. No current can flow in this coil, however, until the circuit is completed between the electrodes. **Thus, the**

electrode circuit voltage being generated within the relay has no connection with the power line.

The BIW 1500 induction relay utilizes the liquid as an electrical conductor to complete the secondary circuit between the upper and lower electrodes. Thus, when the liquid contacts the upper electrode, the resulting flow of current in this circuit sets up a bucking action in the lower bar of the core. This action tends to divert lines of magnetic force to the core legs and sets up an attraction that pulls the armature into contact with the legs, as shown in Figure 2. This armature movement closes the electrode and load contacts.

The lower contacts on 1500-C Relays (terminals 9 and 10) connect the secondary circuit to ground when liquid contacts the upper electrode and act as a holding circuit to maintain the relay in its closed position until the liquid falls below the lower electrode. This holding circuit provides control of the relay over any desired range in the liquid level, depending on the distance between the upper and lower electrodes.

The flow of current through the low energy secondary circuit is very small and varies with the voltage of the secondary coil. The secondary coil is selected to operate over the resistance of the liquid being controlled. Accordingly, since there is a wide range of secondary coils from which to choose, it is important that complete information regarding the nature of the liquid be furnished when ordering B W induction relays.

1500-C RELAY USED FOR PUMP DOWN CONTROL

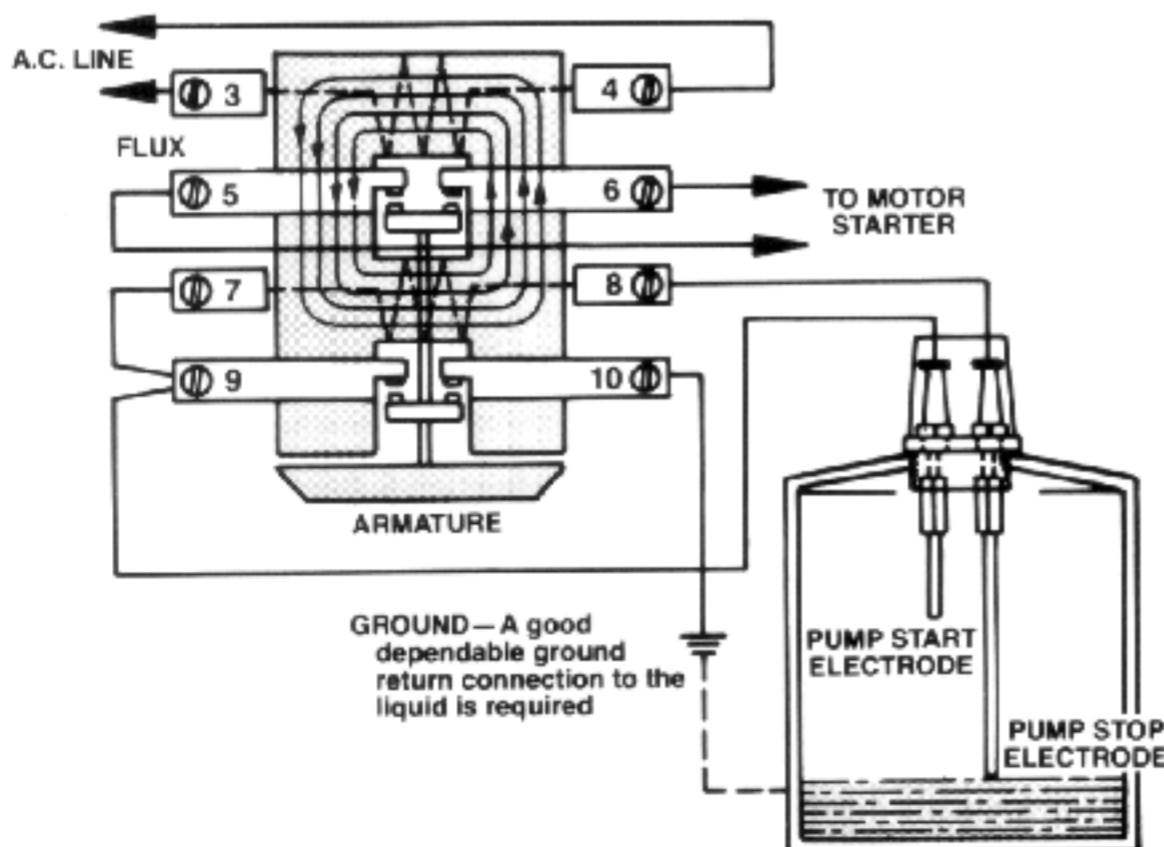

Figure 1—Secondary coil circuit open; armature down.

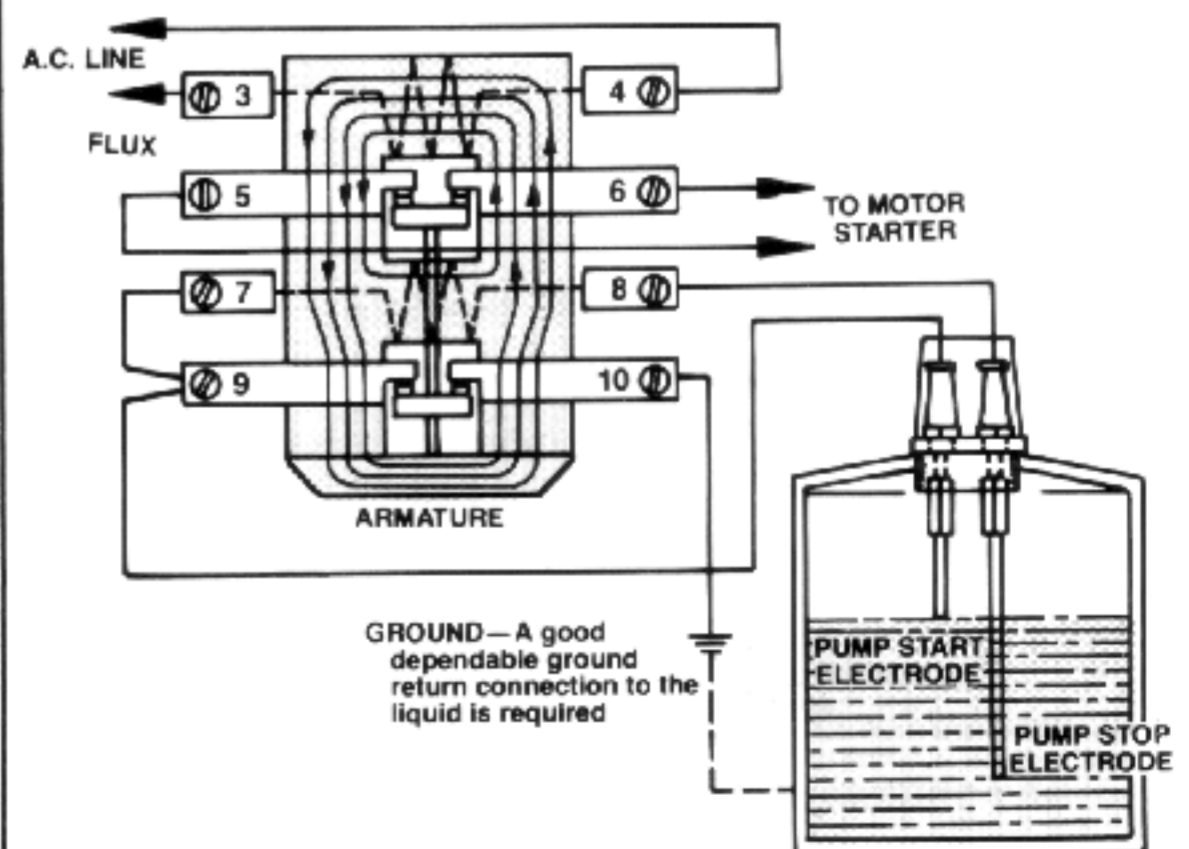

Figure 2—Secondary coil circuit closed; armature up.

INDUCTION RELAY COIL SELECTION DATA

PRIMARY COIL

The primary coil voltage should be chosen to match the line voltage of the control system. The 1500 Series Induction Relay can be supplied with any of the following line voltages:

PRIMARY COIL

LINE VOLTAGE	FREQUENCY (Hertz)	MAXIMUM AMPERES (Secondary Shorted)	B W COIL NUMBER
110-120	50-60	.075	02-089000
208-240	50-60	.038	02-089200
440-480	50-60	.019	02-089300
550-600	50-60	.015	02-089400

SECONDARY COIL SELECTION

Since B|W level control systems use the liquid as an electrical conductor to complete the relay's secondary circuit — and since the resistance of liquids varies, it is necessary that each induction relay be equipped with a secondary coil that will operate over the resistance of the liquid it controls. The following tables list the operating characteristics of various coils available. All values are based on line voltage of 115, 230, 460 or 575 volts at 60 Hertz.

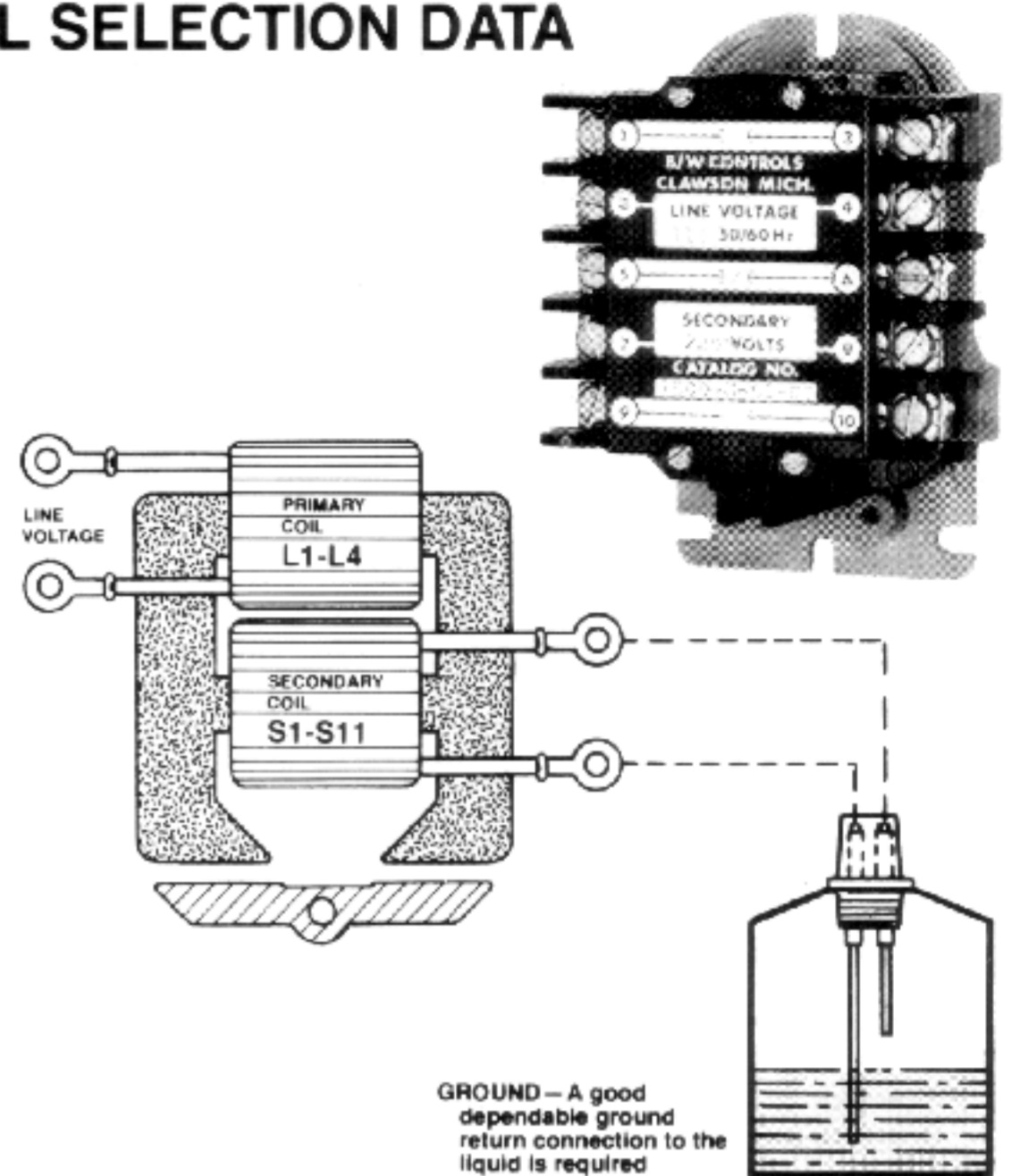

RECOMMENDED SECONDARY COILS FOR VARIOUS TYPES OF LIQUIDS

COIL VOLTAGE	TYPICAL LIQUIDS	MAXIMUM AMPERES (Shorted)	MAX. SPECIFIC RESISTANCE OF LIQUID (ohms-cm)	MIN. SPECIFIC CONDUCTIVITY OF LIQUID (micromho/cm)	COIL NUMBER
12	Metallic circuits.	.44	15	67,000	02-088700
24	Metallic circuits.	.22	61	16,000	02-088800
40	Acid or caustic solutions; Milk; Brine and salt solutions; Plating solutions; Buttermilk; Soups.	.117	216	4,630	02-088900
90	Weak acid or caustic solutions; Beer, Baby foods; Fruit juices.	.053	1,065	940	02-089000
220	Sewage; Most water — except very soft; Pottery slip; Water soluble oil solutions; Starch solutions.	.022	6,650	150	02-089500
360	Very soft water; Sugar syrup.	.013	17,000	59	02-089300
480	Steam condensate; Strong alcohol solutions.	.011	26,600	38	02-089400
800	Demineralized or distilled water.*	.006	92,600	11	02-123700

*Exceptionally pure water produced for some industrial applications requires use of B|W Type 52-Series Solid-State Relay. (See Page 5 of Catalog Section 5200.)

NOTE 1: The maximum closing resistance in ohms over which each coil will operate is approximately equal to the specific resistance values shown above. All B|W relays may be energized indefinitely with the secondary circuit shorted without damaging the coils.

NOTE 2: Maximum distance limitations for typical induction relay secondary circuits are: 220 secondary - 900 feet, 360 secondary - 350 feet, 480 secondary - 250 feet and 800 secondary - 70 feet. For others see Section 8040.

See Page 17 for additional liquids.

RECTIFIED RELAYS FOR D.C. SENSING CIRCUITS

The Series 1500 BIW induction relays can be supplied with the Zener diode module added in the secondary circuit to provide full wave rectified dc outputs for operation from contact type sensors rather than level sensing electrodes. These diodes limit the voltage surge, normally experienced when the secondary circuit is opened, to about 50% above the rated secondary voltage.

Typical applications for these relays include: Detecting metal parts in a press — voltage surge limitation prevents marring polished surfaces and reduces shock hazards. Simultaneous multiple machine control — permits series or parallel connection of relays without regard for phasing of primary coil voltages.

The Zener diode modules can be easily added to either the 12V, 24V or 40V Series 1500 Induction Relays. Shown is the module being attached to terminals 7 and 8 of the relay. To order the Zener diode modules separately, use the following part numbers.



SECONDARY CIRCUIT LIMITATIONS

VOLTAGE		MAX. RESISTANCE (N=No. of Relays)	
Rated	Maximum	Series Connected	Parallel Connected
12 v. dc.	18 v. dc.	15 ohms x N	15 ohms ÷ N
24 v. dc.	36 v. dc.	60 ohms x N	60 ohms ÷ N
40 v. dc.	68 v. dc.	210 ohms x N	210 ohms ÷ N

SECONDARY COIL	ZENER DIODE MODULE PART NO.
12V	15-000019
24V	15-000029
40V	15-000039

MANUAL RESET RELAYS FOR USE WITH ONE ELECTRODE

BIW Manual Reset relays are basic induction relays equipped with a N.O. or N.C. reset button which permits an operator to reestablish the electrode for high or low level cutoff operation. Once a pump has been stopped by the liquid leaving or contacting the electrode, it cannot be started again until the relay has been manually reset by means of the pushbutton. Available as single pole or double pole —

normally open or normally closed — and as single pole, double throw relays. When ordering, please specify operation desired.

NOTE: When ordering a manual reset relay, indicate an "M" for the last digit of the catalog number on page 9, and indicate if a N.O. or N.C. reset button is required.

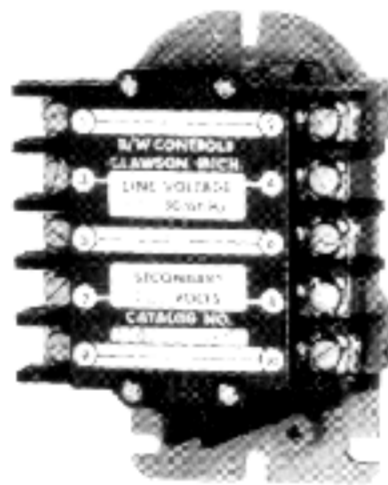

CATALOG CODE

See Pages 8 & 9 for Complete Catalog Numbers

CATALOG CODE	CONTACT ARRANGEMENT			RESET BUTTON	OPERATION AND APPLICATION
	Normally Open	Normally Closed	Holding Circuit		
C	1	0	1	N.O.	Low level cut off with manual reset.
F	2	0	1	N.O.	Same as Type above with additional contact.
D	0	1	1	N.C.	High level cutoff with manual reset.
H	0	2	1	N.C.	Same as above with additional contact.
G	1	1	1	N.C.	High level cutoff and/or signal, manual reset
G	1	1	1	N.O.	Low level cutoff and/or signal, manual reset.

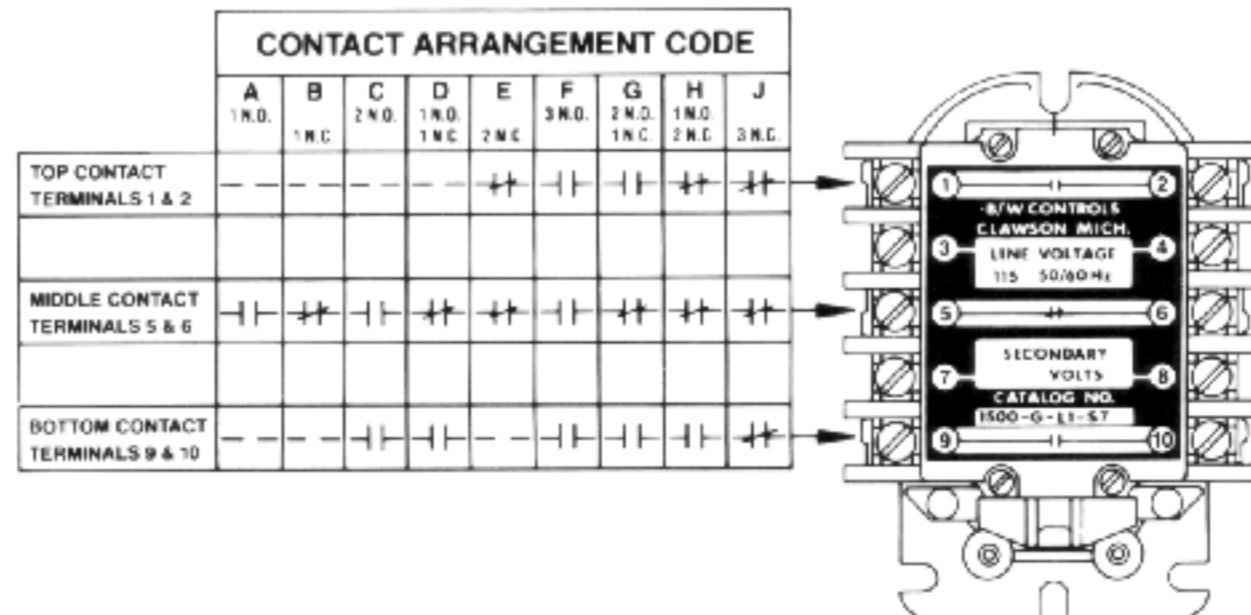

B|W Controls

Induction Relays

REFER TO SERVICE BULLETIN FORM 511 FOR DETAILED WIRING

INDUCTION RELAY CONTACT ARRANGEMENT	WIRING DIAGRAM AND OPERATION	TYPICAL APPLICATIONS						
<p>1500-A RELAY</p> <p>Contact Arrangement</p> <table border="1"> <tr> <td>Normally Open</td> <td>Normally Closed</td> <td>Holding Circuit</td> </tr> <tr> <td>1</td> <td>0</td> <td>0</td> </tr> </table>	Normally Open	Normally Closed	Holding Circuit	1	0	0	<p>Form 594</p>	<p>High Level Signal Control. Low Level Cutoff when wired in series with Stop button in 3-wire pushbutton stations. Remote, long distance and low voltage manual control applications, etc.</p> <p>(Similar to 1100-L)</p>
Normally Open	Normally Closed	Holding Circuit						
1	0	0						
<p>1500-C RELAY</p> <p>Contact Arrangement</p> <table border="1"> <tr> <td>Normally Open</td> <td>Normally Closed</td> <td>Holding Circuit</td> </tr> <tr> <td>2</td> <td>0</td> <td>0</td> </tr> </table>	Normally Open	Normally Closed	Holding Circuit	2	0	0	<p>Form 596</p>	<p>Same as 1500-A Relay above except that an additional Normally Open contact is provided to permit simultaneous operation of different types of secondary signal devices in remote locations.</p> <p>(Similar to 1100-2L)</p>
Normally Open	Normally Closed	Holding Circuit						
2	0	0						
<p>1500-B RELAY</p> <p>Contact Arrangement</p> <table border="1"> <tr> <td>Normally Open</td> <td>Normally Closed</td> <td>Holding Circuit</td> </tr> <tr> <td>0</td> <td>1</td> <td>0</td> </tr> </table>	Normally Open	Normally Closed	Holding Circuit	0	1	0	<p>Form 595</p>	<p>Low Level Signal Control. High Level Cutoff when wired in series with Stop button in 3-wire pushbutton stations. Remote, long distance and low voltage manual control applications, etc.</p> <p>(Similar to 1100-R)</p>
Normally Open	Normally Closed	Holding Circuit						
0	1	0						
<p>1500-E RELAY</p> <p>Contact Arrangement</p> <table border="1"> <tr> <td>Normally Open</td> <td>Normally Closed</td> <td>Holding Circuit</td> </tr> <tr> <td>0</td> <td>2</td> <td>0</td> </tr> </table>	Normally Open	Normally Closed	Holding Circuit	0	2	0	<p>Form 598</p>	<p>Same as 1500-B Relay above except that an additional Normally Closed contact is provided to permit simultaneous operation of different types of secondary signal devices in remote locations.</p> <p>(Similar to 1100-2R)</p>
Normally Open	Normally Closed	Holding Circuit						
0	2	0						
<p>1500-D RELAY</p> <p>Contact Arrangement</p> <table border="1"> <tr> <td>Normally Open</td> <td>Normally Closed</td> <td>Holding Circuit</td> </tr> <tr> <td>1</td> <td>1</td> <td>0</td> </tr> </table>	Normally Open	Normally Closed	Holding Circuit	1	1	0	<p>Form 597</p>	<p>High or Low Level Signal Control. High or Low Level Cutoff when wired in series with Stop button in 3-wire pushbutton stations. Can also be used to interlock various types of signal devices.</p> <p>(Similar to 1100-D)</p>
Normally Open	Normally Closed	Holding Circuit						
1	1	0						

CAUTION: Electrodes are terminals of live electrical circuits and must be installed to prevent accidental contact by personnel. Control power must be disconnected before servicing.

* **A GOOD DEPENDABLE GROUND RETURN CONNECTION TO THE LIQUID IS REQUIRED.**

‡ For direct wiring to a 208-240VAC, 1 phase load device, 2 load contacts are required; see Series 1500E, F & H Relays.

REFER TO SERVICE BULLETIN FORM 511 FOR DETAILED WIRING

INDUCTION RELAY CONTACT ARRANGEMENT	WIRING DIAGRAM AND OPERATION	TYPICAL APPLICATIONS						
<p>1500-C RELAY</p> <p>Contact Arrangement</p> <table border="1"> <tr> <td>Normally Open</td> <td>Normally Closed</td> <td>Holding Circuit</td> </tr> <tr> <td>1</td> <td>0</td> <td>1</td> </tr> </table>	Normally Open	Normally Closed	Holding Circuit	1	0	1	<p>Form 596</p>	<p>Pump Down Control for sewage and sump pumps, condensate return systems, etc. Low Level Cutoff for submersible pumps. Normally closed Solenoid Valve Control for discharging liquids from tanks, etc.</p> <p>(Similar to 1100-LH)</p>
Normally Open	Normally Closed	Holding Circuit						
1	0	1						
<p>1500-F RELAY</p> <p>Contact Arrangement</p> <table border="1"> <tr> <td>Normally Open</td> <td>Normally Closed</td> <td>Holding Circuit</td> </tr> <tr> <td>2</td> <td>0</td> <td>1</td> </tr> </table>	Normally Open	Normally Closed	Holding Circuit	2	0	1	<p>Form 599</p>	<p>Same as 1500-C Relay above except that additional Normally Open contact is provided to permit simultaneous operation of second pump. Extra contact can also be used for signal purposes if desired.</p> <p>(Similar to 1100-2LH)</p>
Normally Open	Normally Closed	Holding Circuit						
2	0	1						
<p>1500-D RELAY</p> <p>Contact Arrangement</p> <table border="1"> <tr> <td>Normally Open</td> <td>Normally Closed</td> <td>Holding Circuit</td> </tr> <tr> <td>0</td> <td>1</td> <td>1</td> </tr> </table>	Normally Open	Normally Closed	Holding Circuit	0	1	1	<p>Form 597</p>	<p>Pump Up Control for supply pumps on elevated tanks and towers, carbonators, etc. High Level Cutoff for pumps and valves. Normally closed Solenoid Valve Control for plating tank and boiler make-up, etc.</p> <p>(Similar to 1100-RH)</p>
Normally Open	Normally Closed	Holding Circuit						
0	1	1						
<p>1500-H RELAY</p> <p>Contact Arrangement</p> <table border="1"> <tr> <td>Normally Open</td> <td>Normally Closed</td> <td>Holding Circuit</td> </tr> <tr> <td>0</td> <td>2</td> <td>1</td> </tr> </table>	Normally Open	Normally Closed	Holding Circuit	0	2	1	<p>Form 601</p>	<p>Same as 1500-D Relay above except that additional Normally Closed contact is provided to permit simultaneous operation of second pump. Extra contact can also be used for signal purposes if desired.</p> <p>(Similar to 1100-2RH)</p>
Normally Open	Normally Closed	Holding Circuit						
0	2	1						
<p>1500-G RELAY</p> <p>Contact Arrangement</p> <table border="1"> <tr> <td>Normally Open</td> <td>Normally Closed</td> <td>Holding Circuit</td> </tr> <tr> <td>1</td> <td>1</td> <td>1</td> </tr> </table>	Normally Open	Normally Closed	Holding Circuit	1	1	1	<p>Form 600</p>	<p>Pump Up or Pump Down Control for same applications listed above for BIW 1500-C and 1500-D Relays. It is also suitable for use in controlling hydropneumatic tanks and motorized valve installations.</p> <p>(Similar to 1100-DH)</p>
Normally Open	Normally Closed	Holding Circuit						
1	1	1						

CAUTION: Electrodes are terminals of live electrical circuits and must be installed to prevent accidental contact by personnel. Control power must be disconnected before servicing.

* A GOOD DEPENDABLE GROUND RETURN CONNECTION TO THE LIQUID IS REQUIRED.

‡ For direct wiring to a 208-240VAC, 1 phase load device, 2 load contacts are required; see Series 1500E, F & H Relays.

BIW Controls

Induction Relays

CONDUCTIVE LIQUIDS

With the exception of products such as oil, gasoline, animal fats and other similar products, most liquids and some moist bulk materials have sufficient conductivity to use BIW level detecting relays. The Series 1500 relay can be used on liquids with resistance up to about 90,000 ohm-cm (conductivity to 11 micromho/cm). For liquids with higher resistance the BIW Series 5200 relays must be used for applications up to 12 megohms resistance. The vapor above some liquids is considered an explosive hazard and in these cases the BIW Series 5300 and 5510 relays with intrinsically safe sensing circuit should be used.

Liquids such as milk and beer, and some pharmaceutical products will foam during processing. The liquid phase is always a better conductor than the foam, and when the interface level is to be detected, the relay sensitivity must be carefully selected and it would be well to check the factory for our recommendation.

With nearly 50 years of experience Patriot has compiled a history of applications in most major industries around the world. If you have questions regarding the proper relay selection, write us, phone us, or send a sample for test. Chances are that we have the answer for you.

TYPICAL LIQUIDS

The following recommendations are satisfactory for general use, but because the conductivity of liquids varies greatly with concentration, purity, temperature and other factors, some applications may require a different selection.

A number of the products listed are produced as solids such as crystals or powders, and our relay selection is based on the normally used commercial solutions of these materials.

Liquid Description	Secondary Coil
Acetic Acid — Up to 75%	90 Volt *
— 75 to 90%	220 Volt *
— Glacial	Use 5200-H Relay
Acetone	Use 5200-H or 5300 Relay
Acids — General	40 or 90 Volt *
— Anhydrous	Use 5200-H Relay
Alcohols	Use 5200-H or 5300 Relay
Alkalies — General	40 or 90 Volt
— Anhydrous	Use 5200-H Relay
Alum Solutions	220 Volt
Aluminum Sulphate	90 Volt
Aluminum Hydroxide	90 Volt
Amino Acids	90 Volt
Ammonia-Anhydrous Liquid	Use 5200-H Relay
Ammonium Chloride	40 Volt
Ammonium Hydroxide (Ammonia)	220 Volt
Ammonium Nitrate	Use 5300 Relay
Ammonium Sulphate	220 Volt
Baby Foods	90 Volt
Barium Chloride	40 Volt
Barium Nitrate	40 Volt
Beer	90 Volt
Black Liquor	40 Volt
Blood	220 Volt
Borax — Up to 10%	220 Volt
— Greater than 10%	90 Volt
Boric Acid	220 Volt
Bread Dough	90 Volt
Buttermilk	24 or 40 Volt
Cadmium Chloride	40 Volt
Cake Batter	220 Volt
Calcium Chloride	40 Volt
Calcium Hydroxide	220 Volt
Carbolic Acid — Up to 90%	220 Volt
— 90 to 100%	Use 5200-H Relay
Catsup	90 Volt
Caustic Soda (Sodium Hydroxide)	40 Volt
Cement Slurry	220 Volt
Chromic Acid	40 Volt *
Citric Acid	40 or 90 Volt *
Coffee	90 Volt
Condensate — Ordinary Water	480 Volt
— D.I. Water	Use 5200-H Relay
Corn Syrup	480 Volt
Corn — Cream Style	90 Volt
Ethylene Glycol	Use 5200-H Relay
Ferric Chloride	Use 5200-L Relay
Ferrous Sulphate	220 Volt

Liquid Description	Secondary Coil
Formaldehyde	Use 5200-H Relay
Formic Acid — Up to 75%	90 Volt *
— 75 to 90%	220 Volt *
Glycerine (Glycerol)	Use 5200-H Relay
Hydrochloric Acid	Use 5200-L Relay
Hydrofluoric Acid — Up to 20%	220 Volt *
— Above 20%	40 Volt *
Hydrofluorsilicic Acid	90 Volt *
Hydrogen Peroxide	Use 5200-H or 5300 Relay
Jams & Jellies	360 Volt
Juices — Fruit & Vegetable	40 or 90 Volt
Lemon Oil Essence	Use 5200-H Relay
Lignite	800 Volt
Lithium Chloride	40 Volt
Magnesium Hydroxide	90 Volt
Mayonnaise	220 Volt
Methanol	Use 5200-H or 5300 Relay
Methyl Ethyl Ketone (MEK)	Use 5200-H Relay
Milk	40 Volt
Molasses	220 Volt
Muriatic Acid	40 Volt *
Mustard	40 Volt
Nitric Acid	40 or 90 Volt *
Orange Juice	90 Volt
Paper Stock	220 Volt
Penicillin	220 Volt
Phosphoric Acid	40 Volt *
Plating Solutions	40 or 90 Volt *
Salts — Chemical	40 or 90 Volt *
Sodium Carbonate (Soda Ash)	90 Volt
Sodium Chloride (Table Salt)	40 Volt *
Sodium Hydroxide (Caustic Soda)	40 Volt *
Sodium Hypochlorate	40 Volt
Sodium Silicate (Water Glass)	90 Volt
Soups	40 Volt
Starch Solutions	220 Volt
Sugar — Low Concentrations	220 Volt
— High Concentrations	360 Volt
Sulphuric Acid	Use 5200-L Relay
Vinegar	90 Volt
Water — Sea	40 Volt
— Ordinary Potable	220 Volt
— Ordinary Soft	360 Volt
— Ordinary Condensate	480 Volt
— Purified Distilled	800 Volt or 5200-H Relay
— Purified Deionized	Use 5200-H Relay
Zinc Chloride	40 Volt

* Use 5200-L to minimize corrosion

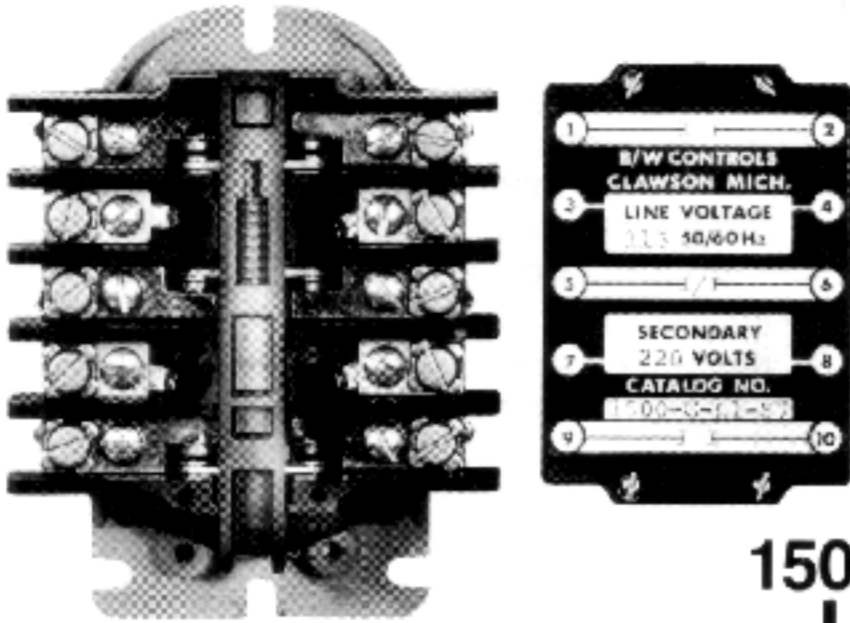

Cat. No. 1500-G-L1-S7
Shown with cover removed

INDUCTION TYPE CATALOG NUMBER



Catalog
Section

	CONTACT ARRANGEMENTS	
	NORMALLY OPEN	NORMALLY CLOSED
A	1	0
B	0	1
C	2	0
D	1	1
E	0	2
F	3	0
G	2	1
H	1	2
J	0	3

	LINE VOLTAGE
L1	110-120 Volts 50/60 HZ
L2	208-240 Volts 50/60 HZ
L3	440-480 Volts 50/60 HZ
L4	550-600 Volts 50/60 HZ
L5	120/240 Volts 50/60 HZ
Dual Voltage List \$6.00	

Consult Factory For Special Line Voltages.

All contacts rated at:
 25 Amp Resistive at 120, 240, or 480 VAC
 1 HP Single Phase at 120 or 240 VAC
 Heavy Duty Pilot 120 to 600 VAC
 2 Amp Resistive at 120 VDC
 10 Amp Resistive at 48 VDC

B/W PART NUMBER CROSS REFERENCE

OLD PART NO.	1100 RELAY	1500 RELAY
11-045000	1100-LH-*	1500-C-*
11-045300	1100-2LH-*	1500-F-*
11-044500	1100-RH-*	1500-D-*
11-044800	1100-2RH-*	1500-H-*
11-045500	1100-DH-*	1500-G-*
11-044900	1100-L-*	1500-A-*
11-045200	1100-2L-*	1500-C-*
11-044300	1100-R-*	1500-B-*
11-044700	1100-2R-*	1500-E-*
11-045400	1100-D-*	1500-D-*
11-045100	1100-LM-*	1500-C-*
11-052900	1100-2LM-*	1500-F-*
11-044600	1100-RM-*	1500-D-*
11-053000	1100-2RM-*	1500-H-*
11-052800	1100-DM-1-*	1500-G-*
11-045600	1100-DM-2-*	1500-G-*
		*See Catalog Numbering for Completion of Catalog Number.

EXAMPLE: A liquid level application requires 1 N.O., 1 N.C. and 1 N.O. Holding Contact. The line voltage available is 115 VAC. It is desired to detect the level of storm run-off water. The installation is outside requiring a Nema 4 water tight enclosure.

CAT. NO. 1500—G—L1—S8—N4—X

BIW Controls

Induction Relays

CONTROL RELAY WIRING SYSTEM

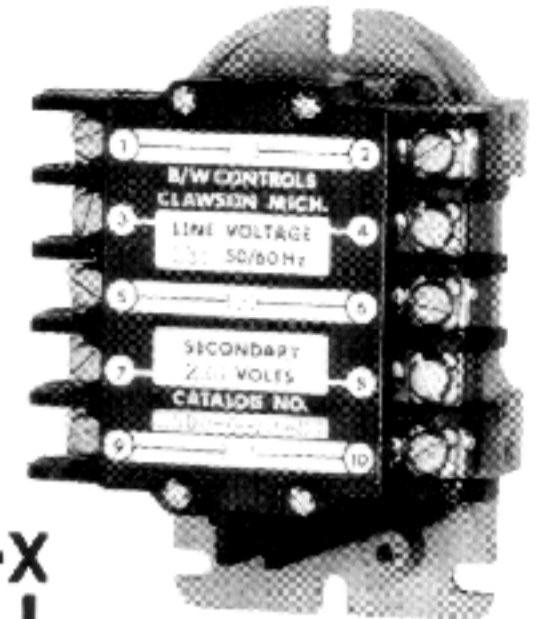

S7		
	• SECONDARY COIL VOLTAGE	TYPICAL LIQUIDS
S1	12 Volts A.C.	Metallic circuits
S2	24 Volts A.C.	Metallic circuits
S3	40 Volts A.C.	Acid or caustic solutions; Milk; Brine and salt solutions; Plating solutions; Buttermilk; Soups.
S4	90 Volts A.C.	Weak acid or caustic solutions; Beer; Baby foods; Fruit juices.
S7	220 Volts A.C.	Sewage; Most water-except very soft; Pottery slip; Water soluble oil solutions; Starch solutions.
S8	360 Volts A.C.	Very soft water; Sugar syrup.
S9	480 Volts A.C.	Steam condensate; Strong alcohol solutions.
S11	800 Volts A.C.	Demineralized or distilled water.*
S1Z	12 Volts A.C.	17 Volt D.C. Sensing Circuit
S2Z	24 Volts A.C.	34 Volt D.C. Sensing Circuit
S3Z	40 Volts A.C.	56 Volt D.C. Sensing Circuit

X	
	ADDITIONAL OPTIONS
X	None
M	Manual Reset Button NOTE: See page 5 for manual reset relay. Consult factory for NEMA 7 manual reset option.

N1	
	TYPE OF ENCLOSURE
OC	Open Chassis
N1	Nema 1, General Purpose
N4	Nema 4, Weather Proof, Watertight & Dust Tight
N4X	Nema 4X Fiberglass Watertight, Dust Tight & Corrosion Resistant
N7	Nema 7, Class I, Group D; Class II, Groups E, F & G
N12	Nema 12, Oil Tight



NEMA 1



NEMA 4

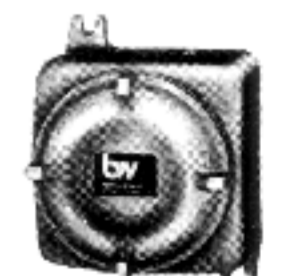

NEMA 7



NEMA 12

• Additional Secondary Coil Voltages Available - Consult Factory
 * Exceptionally Pure Water May Require BIW 5200H Series Relay. Catalog Page 18

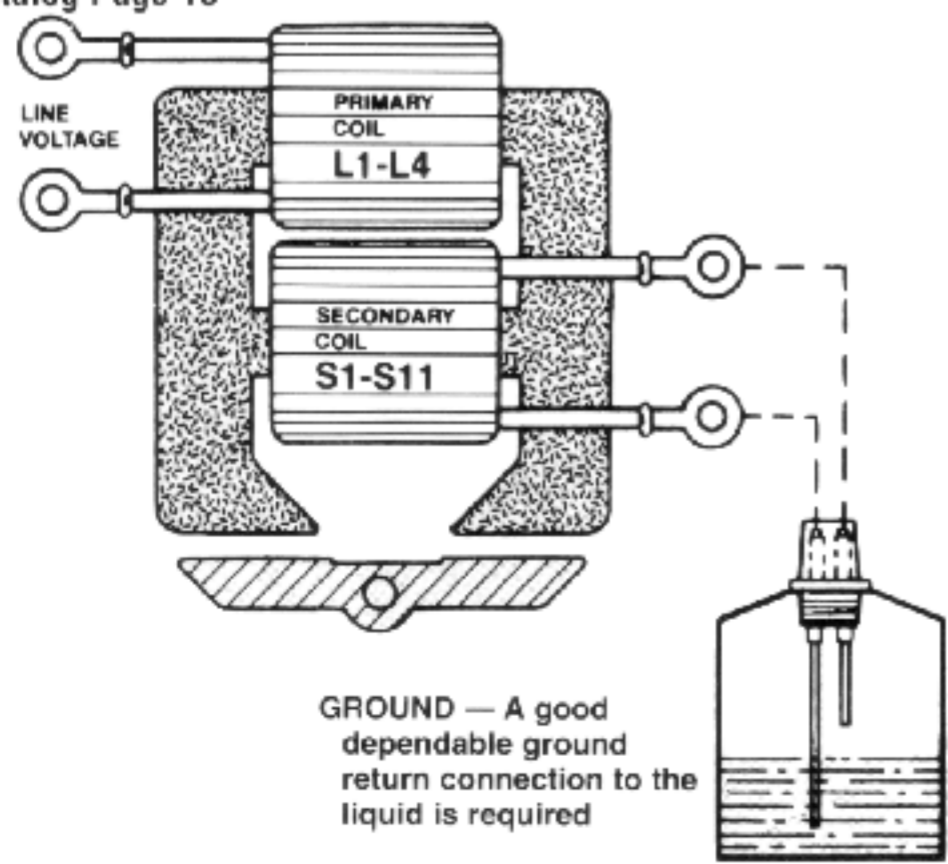

GROUND — A good dependable ground return connection to the liquid is required

DIMENSIONS

OPEN CHASSIS

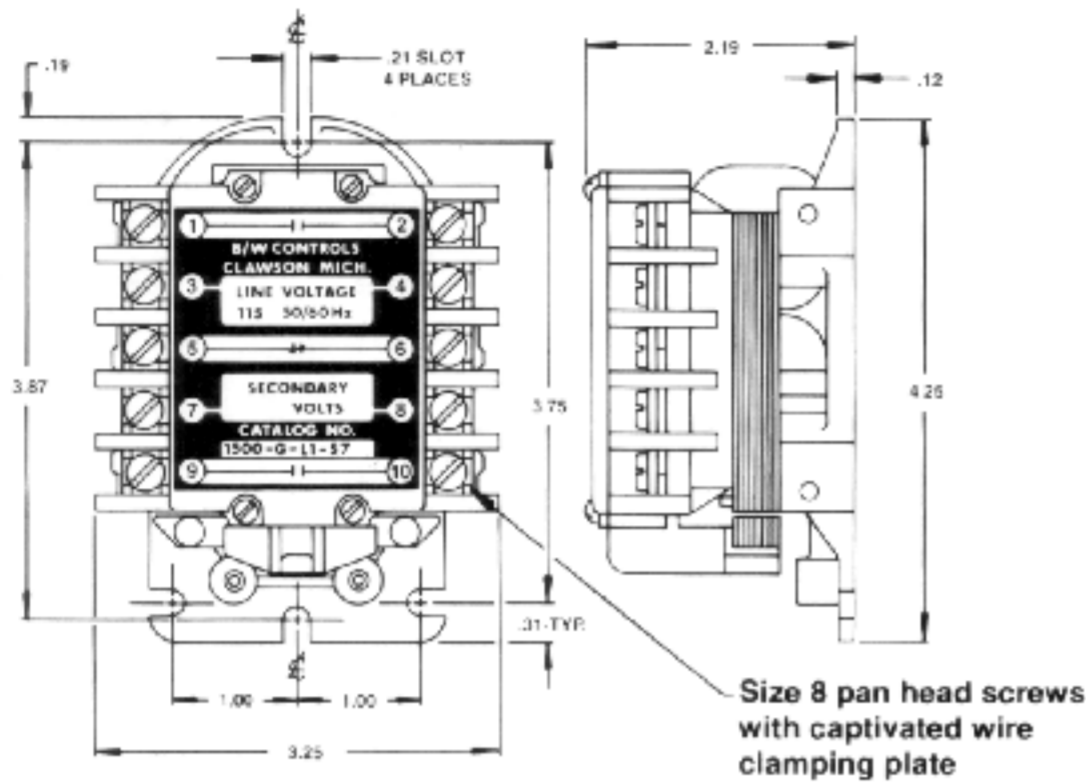

Approx. Shipping weight
1.5 pounds.

NEMA TYPE 1 GENERAL PURPOSE ENCLOSURE

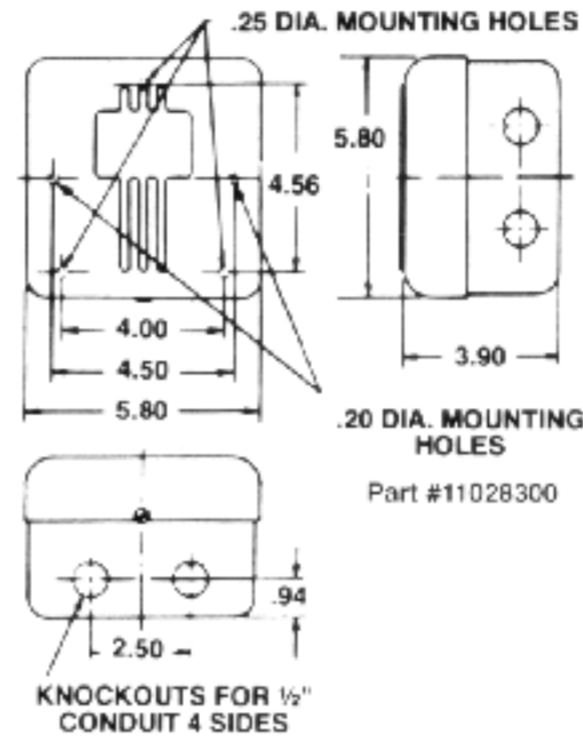

Approx. shipping weight:
5 pounds with relay.

NEMA TYPE 4 WATER & DUST TIGHT ENCLOSURE

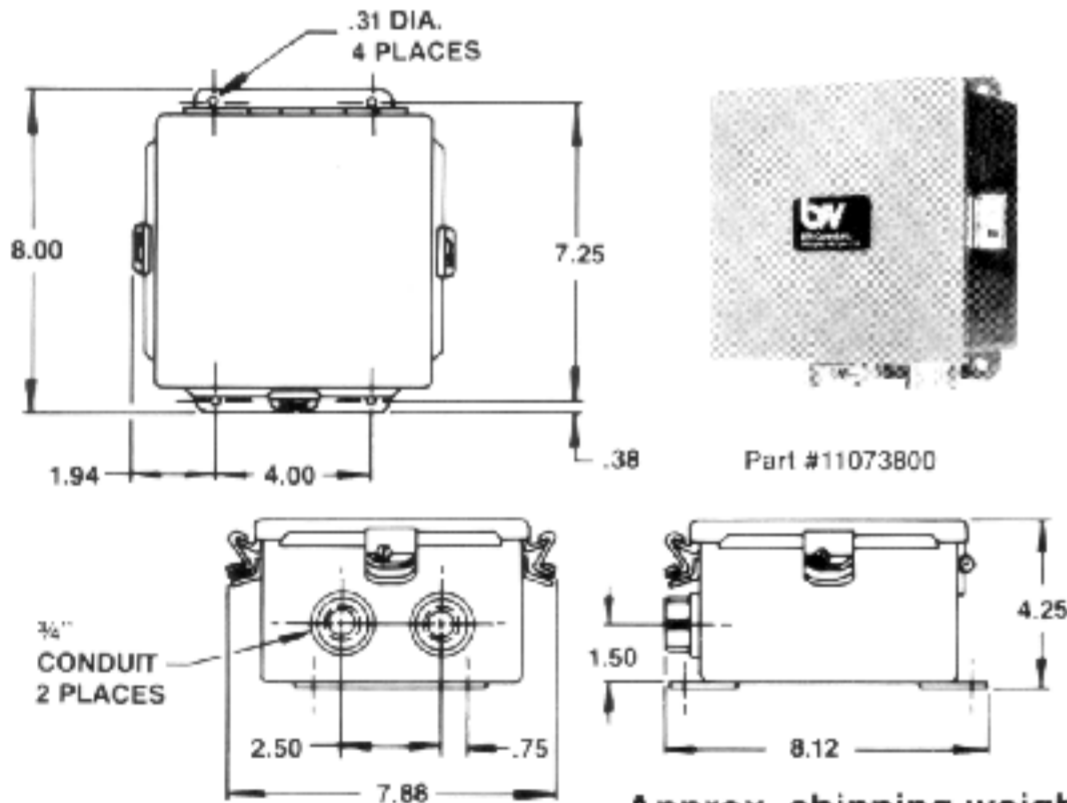

Approx. shipping weight:
9 pounds with relay.

NEMA TYPE 7 EXPLOSION-PROOF ENCLOSURE

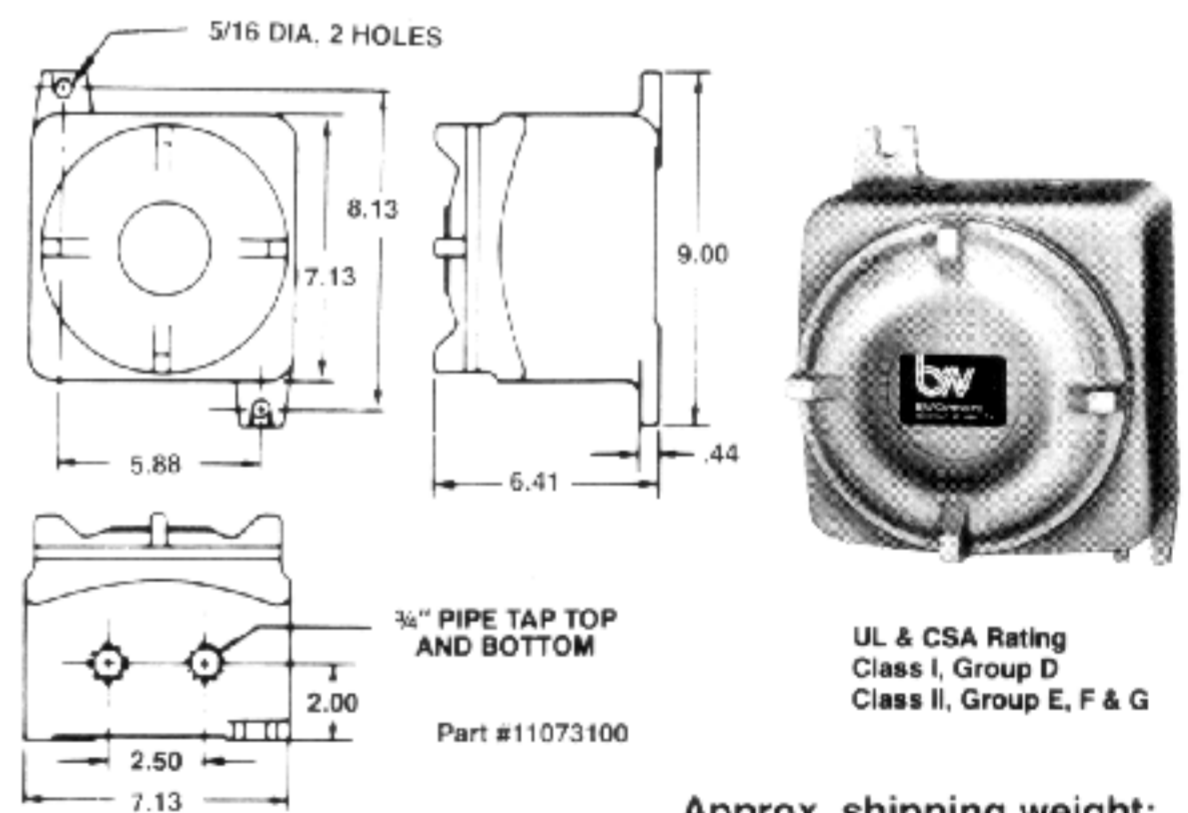

Approx. shipping weight:
12 pounds with relay.



UL & CSA Rating
Class I, Group D
Class II, Group E, F & G

NEMA TYPE 12 OIL-TIGHT ENCLOSURES

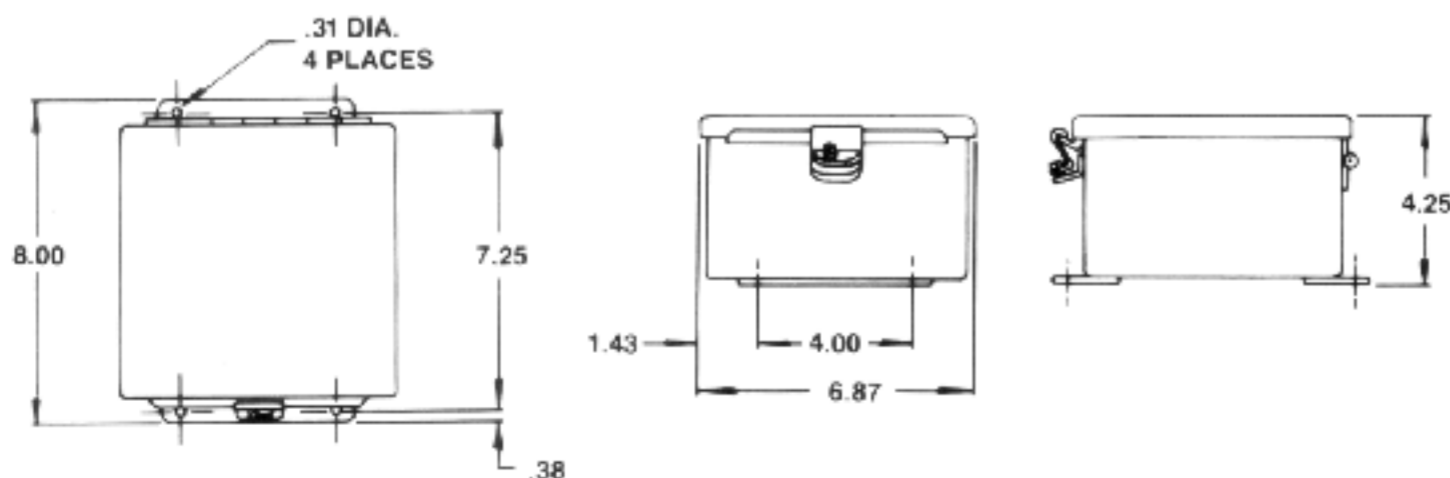

Approx. shipping weight:
7 pounds with relay.



Part #11073900