

KBCC™

Chassis Mount Variable Speed DC Motor Control
for Shunt Wound and PM Motors thru 3 Hp

Patented Overload Circuit

TYPICAL APPLICATIONS

- Transfer Pumps • Door Openers • Feeders
- Indexers • Tapping Machines • Conveyors
- Robotics • Screen Presses
- Exercise Equipment

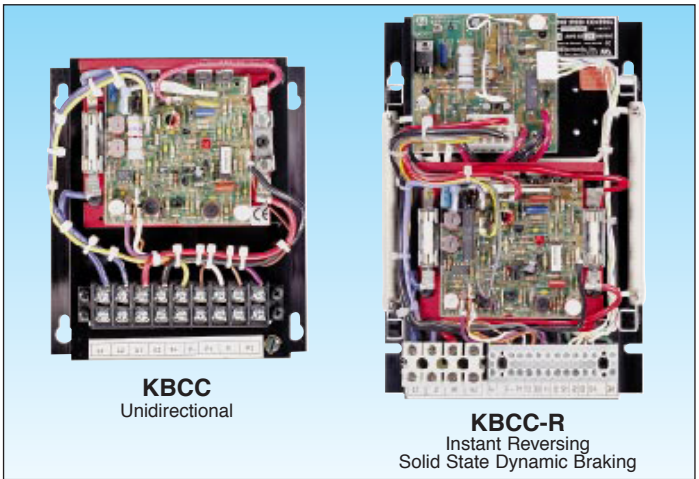

STANDARD FEATURES – All Models

- Tachometer or Armature Feedback
- Plug-in Horsepower Resistor®[▲]
- Built-in AC Line and Armature[▲] Fuses
- MOV Transient Protection
- Trimpots: MIN, MAX, IR, CL, ACCEL, DECEL
- Rugged Aluminum Heatsink
- Voltage Following
- Auto Inhibit®, Inhibit™ and Enable
- CL LED Indicator

SPECIAL FUNCTIONS – “R” Suffix Only

- Forward-Brake-Reverse
- Anti-plug Instant Reverse
- Run-Brake-Jog
- Auxiliary Trimpot for Speed Adjustment
- Rapid Cycling

[▲] Armature Fuse and Plug-in Horsepower® are supplied separately.

SPECIFICATIONS

Speed Range (Ratio)	50:1
Load Regulation (0 – Full Load, 50:1 Speed Range)(% Base Speed)	1*
Line Voltage Regulation (At Full Load, ± 15% Line Variation) (% Base Speed)....	1/2*
Control Linearity (% Speed vs. Dial Rotation)	2
CL Torque Range (% Full Load)	0 – 200
ACCEL/DECEL Time Range (Secs.)2 – 10
MIN Speed Trimpot Range (% Full Speed)	0 – 30*
MAX Speed Trimpot Range (% Full Speed)	50 – 120*
Maximum Allowable Ambient Temperature (At Full Rating °C/°F)	45/113
Maximum Number of Starts/Stops or Reversals (Operations/Minute).....	30**

* Performance is for 90V PM motors on 115 VAC and 180V PM motors on 230 VAC.

** Based on a brake time of one (1) second. For increased operations per minute and longer brake time, contact factory.

* CE Compliance Requires KBRF-200A RFI Filter

DESCRIPTION

The KBCC chassis control utilizes the KBMM™ modular control to provide a low-cost, reliable, variable speed SCR drive for PM and Shunt Wound DC motors. Models with the “R” suffix contain the KB APRM®* which provides anti-plug “instant” reverse and solid state dynamic braking. All models are equipped with KB’s exclusive Plug-in Horsepower Resistor®. It eliminates the need for recalibrating IR Comp and Current Limit when the control is used on various horsepower motors. The controls also contain Inhibit™ which allows for electronic switching of the armature voltage and Auto Inhibit® which provides rapid safe switching of the AC line.

The KBCC controls are built on a rugged aluminum heatsink and contain AC line and armature fusing, a 5K ohm remote potentiometer, and a barrier terminal block. In lieu of the potentiometer, the control can be operated in a voltage following mode by supplying an *isolated* analog signal (0-9VDC) to the input terminals P2 (+) and F-. Adjustment trimpots are provided for MIN, MAX, IR COMP, CL, ACCEL and DECEL.

* Patented.

PLUG-IN HORSEPOWER RESISTOR® CHART

Motor Horsepower Range		Plug-in-Horsepower Resistor® Resistance Value (ohms)
Armature Voltage 90 – 130 VDC	Armature Voltage 180 VDC	
1/100 – 1/50	1/50 – 1/25	1.0
1/50 – 1/30	1/25 – 1/15	.51
1/30 – 1/20	1/15 – 1/10	.35
1/20 – 1/12	1/10 – 1/6	.25
1/12 – 1/8	1/6 – 1/4	.18
1/8 – 1/5	1/4 – 1/3	.1
1/4	1/2	.05
1/3	3/4	.035
1/2	1	.025
3/4	1½	.015
1	2	.01
1½	3	.006



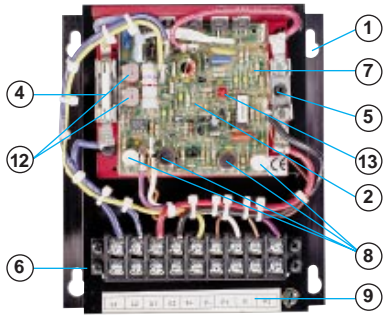

FEATURES & FUNCTIONS

- (1) Rugged Aluminum Heatsink
- (2) KBMM™ Speed Control
- (3) APRM® Reversing Module
- (4) AC Line Fuse included
- (5) Armature Fuse (Customer supplied)
- (6) Barrier Terminal Block
- (7) Plug-in Horsepower Resistor®
- (8) Trimpots: MIN, MAX, IR and CL
- (9) Keyhole slots facilitate mounting
- (10) Aux. Trimpots for Speed Adjustment
- (11) Dynamic Brake Resistor
- (12) Trimpots: ACCEL, DECEL
- (13) CL LED Indicator

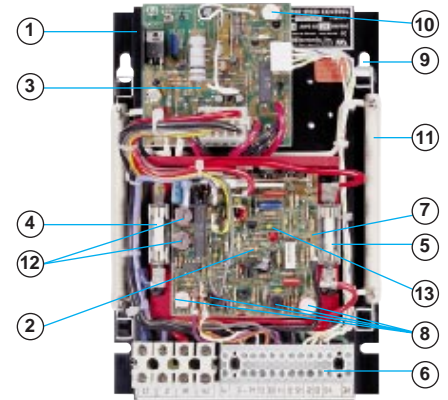

ELECTRICAL RATINGS

Unidirectional		Reversing		AC Line Voltage (VAC) ±15% 50/60 Hz	Max AC Load Current (RMS Amps)	Max DC Load Current (Avg. Amps)	Maximum Horsepower [Hp, (KW)]	AC Line Fuse Rating (A)
Model Number	KB Part Number	Model Number	KB Part Number					
KBCC-125	9936	KBCC-125R	9937	115	24.0	16.0	1.5, (1.1)	25
KBCC-225	9938	KBCC-225R	9924	230	24.0	16.0	3, (2.3)	25

MECHANICAL SPECIFICATIONS

INCHES
[mm]

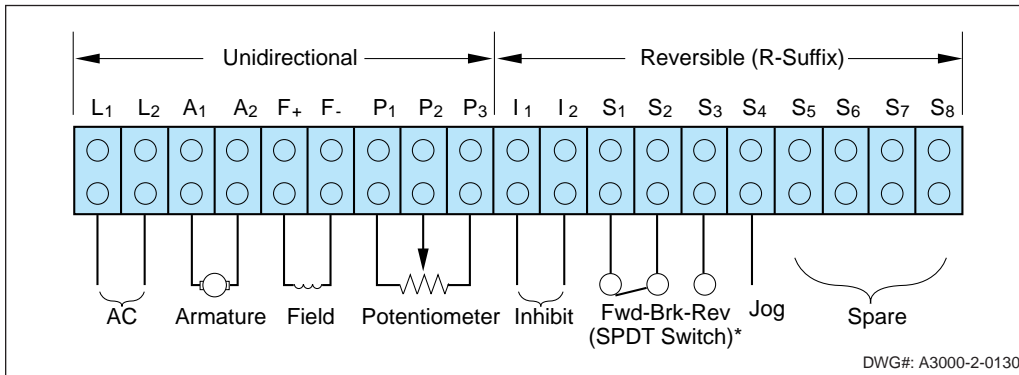
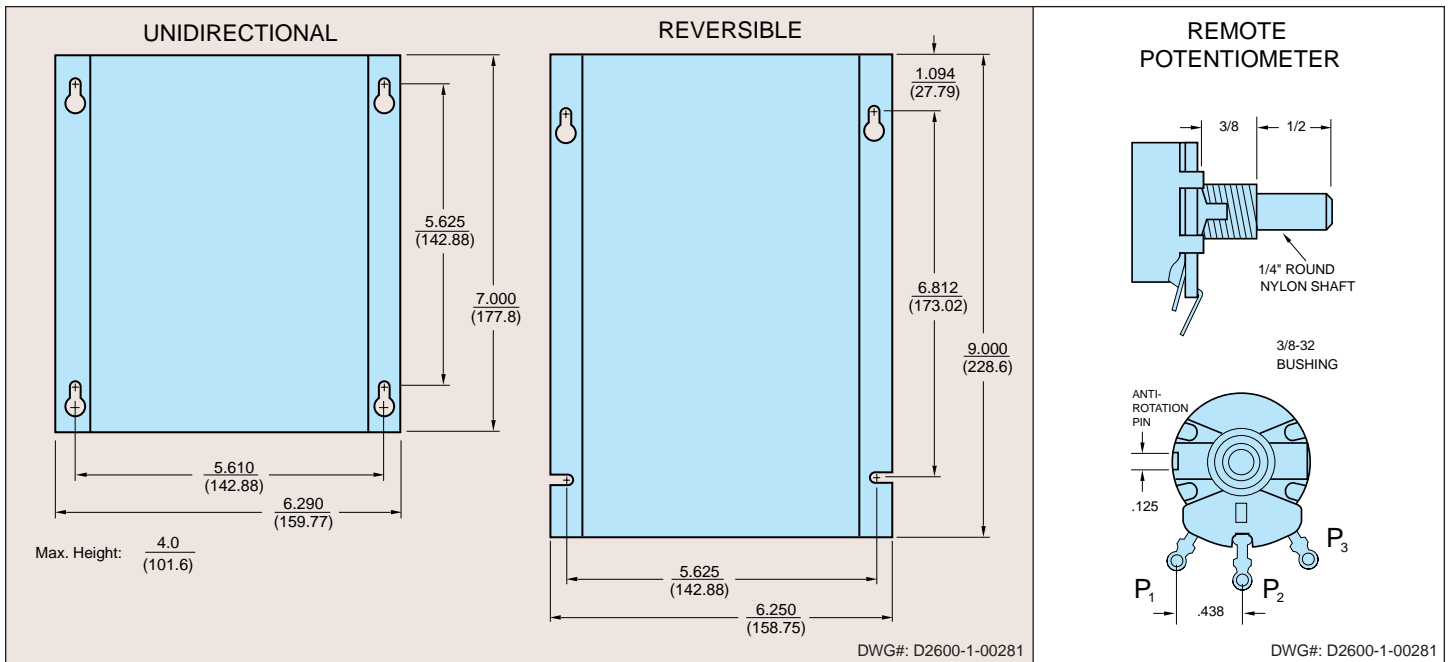

WIRING

R-suffix models are equipped with the KB APRM®. For detailed connection diagram see "KBCC-R Connection Diagrams."

Note: *Only 10 mA of current is switched. Any switch or relay may be used except a solid state type.

© 1998 KB Electronics, Inc.



KB ELECTRONICS, INC.

12095 NW 39th Street, Coral Springs, FL 33065-2516
 (954) 346-4900 • FAX (954) 346-3377
 Outside Florida Call TOLL FREE (800) 221-6570
 www.kbelectronics.com