

MULTI-DRIVE™
Solid State
DC Motor
Speed Control
With
Adj. Acceleration
& Deceleration

Model KBMD-240D



KB Part No.
9370A

Installation
and
Operating
Instructions

See **SAFETY WARNING** on page 4.

- Dual Voltage Input (120V or 240V)
- Up to 1HP-120V & 2HP-240V with Auxiliary Heatsink* (P/N 9861)
- Multiple Horsepower capability with Plug-In Horsepower Resistor® (Supplied Separately)
- Forward-Brake-Reverse Switch (P/N 9860) (Optional)
- Rugged NEMA 1 enclosure
- Contains AC Line and Armature Fusing**
- Patented KBMM Speed Control Module
- Current Limit LED Indicator

* Rating without Heatsink is 3/4HP at 120V and 1-1/2HP at 240V.

** Armature Fuse supplied separately.



PENTA  POWER™

Spec Tech Industrial 203 Vest Ave. Valley Park, MO 63088 Phone: 888 SPECTECH
Email: sales@spectechind.com www.spectechind.com

© 1997 KB ELECTRONICS, INC.

IMPORTANT

Read these simplified instructions before operating control.

(Remove (2) 6-32 screws and slide off front cover.)

- Set the Dual Voltage Switch to the correct AC line input voltage, "115" or "230."
- Install the correct Plug-In Horsepower Resistor® according to input voltage and motor horsepower (see chart)—Table 3, page 3.
- Install proper size Armature Fuse—(see Fuse Selection Chart).
- Install Auxiliary Heatsink on controls used with motors rated above 3/4 HP on 120 volts and 1-1/2 HP on 240 volts.
- Recheck connections: AC line to L1 and L2; armature to A+ and A-; and field (Shunt motor only) to F+ and F-. Connect ground via ground screw. (Note if motor runs in improper direction reverse armature leads.)
- Nominal trimpot settings are as follows (expressed in % of full CW rotation):

Table 1

MIN (minimum speed):	15%
MAX (maximum speed):	60%
IR (IR compensation):	15%
CL (current limit/torque):	65%
ACCEL (acceleration start):	20%
DECEL (deceleration):	20%

- (For detailed instructions see Selection IV, pages 9 & 10.)

FOR TECHNICAL ASSISTANCE CALL TOLL FREE (OUTSIDE FLORIDA ONLY) 1-800-221-6570.

LIMITED WARRANTY

For a period of 18 months from date of original purchase KB will repair or replace without charge devices which our examination proves to be defective in material or workmanship. This warranty is valid if the unit has not been tampered with by unauthorized persons, misused, abused, or improperly installed and has been used in accordance with the instructions and/or ratings supplied. The foregoing is in lieu of any other warranty or guarantee expressed or implied, and we are not responsible for any expense (including installation and removal), inconvenience, or consequential damage, including injury to any person, caused by items of our manufacture or sale. Some states do not allow certain exclusions or limitations found in this warranty so that they may not apply to you. In any event, KB's total liability, under all circumstances, shall not exceed the full purchase price of this unit. (Rev. 10/84)

The information contained in this brochure is intended to be accurate. However, the manufacturer retains the right to make changes in design which may not be included herein.

Multi-Drive[®] is versatile.

• DUAL AC VOLTAGE

1. The basic Model KBMD-240D has dual AC line voltage input capability** which provides 0-full speed capability on DC motors from 1/100th-3/4 HP at 120 VAC and 1/50th-1-1/2 HP at 240 VAC (set the Dual Voltage Switch to the corresponding input voltage "115" or "230").

• HORSEPOWER EXTENDER

2. Add the KB Auxiliary Heatsink to increase the horsepower



KBMD-240D



KBMD-240D
With Auxiliary
Heatsink
& FWD-BRK-REV Switch

NOTE: An optional FORWARD-BRAKE-REVERSE Switch is available.

TABLE 2. ELECTRICAL RATINGS*

MODEL NUMBER	AC LINE VOLTAGE (VAC)**	MOTOR VOLTAGE (VDC)***	AC LOAD CURRENT (RMS AMPS)	DC LOAD CURRENT (AVG. AMPS)	MAX. HP
KBMD-240D Without Auxiliary Heatsink	120	90-130	12.0	8.0	3/4
	240	180	12.0	8.0	1-1/2
KBMD-240 With Auxiliary Heatsink	120	90-130	16.0	11.0	1
	240	180	16.0	11.0	2

* The Multi-Drive[®] can be converted to the higher rating by installing KB's Auxiliary Heatsink.

** The Multi-Drive[®] must be set for either 120 V or 240 VAC line voltage input by setting the Dual Voltage Switch to "115" or "230". When the control is set for "115" use only 90-130 VDC rated motors. When the control is set for "230" use only 180 VDC rated motors.

*** The Multi-Drive[®] also supplies field voltage for shunt motors as follows:

On 120 VAC line, field voltage is 100 VDC using F-, F+ and 50 VDC using L-, F-

On 240 VAC line, field voltage is 200 VDC using F-, F+ and 100 VDC using L-, F-

capability to 1/100th-1 HP at 120 VAC and 1/50-2 HP at 240 VAC. KB Part No. SC-9861.

• ALL MOTOR SIZES

3. Multi-Drive[®] adapts to a complete range of motor horsepower by selecting and installing the proper Plug-In Horsepower Resistor[®] (see chart).

• REVERSIBLE

4. A FWD-BRK-REV Switch Kit is available as an option.



KB Part No.
SC-9860

Forward Brake
Reverse Switch



Plug-In
Horsepower
Resistor[®]

TABLE 3. PLUG-IN HORSEPOWER RESISTOR CHART***

AC LINE VOLTAGE		PLUG-IN HORSEPOWER RESISTOR* (Resistance Value-OHMS) **
120 VAC	240 VAC	
MOTOR HORSEPOWER RANGE		PLUG-IN HORSEPOWER RESISTOR* (Resistance Value-OHMS) **
ARMATURE VOLTAGE 90-130 VDC	ARMATURE VOLTAGE 180 VDC	
1/100-1/50	1/50-1/25	1.0
1/50-1/30	1/25-1/15	.51
1/30-1/20	1/15-1/10	.35
1/20-1/12	1/10-1/6	.25
1/12-1/8	1/6-1/4	.18
1/8-1/5	1/4-1/3	1
1/4	1/2	.05
1/3	3/4	.035
1/2	1	.025
3/4	1 1/2	.015
1*	2*	.01

Motor horsepower and armature voltage must be specified when ordering so that proper Horsepower Resistor[®] will be supplied.

* Use with Auxiliary Heatsink

** For overlapping motor horsepower range use lower value Plug-In Horsepower Resistor[®].

*** Customer choice use PWR and avoid recalibration or select one resistor and recalibrate for different motors.

TABLE OF CONTENTS

Section	Page
Simplified Instructions	
Warranty	2
MULTI-DRIVE[®] Versatility	
Electrical Ratings	3
Introduction	6
I Application Information	6
A. Motor Type	6
B. Torque Requirements	6
C. Acceleration Start	6
D. Limitations in Use	6
II Installation Instructions	7
A. Location and Mounting	7
B. Initial Setup	7
C. Wiring	7
D. Fusing	8
III Operation	9
IV Adjustments and Control	
Functions	9
A. Acceleration Start (ACCEL)	9
B. Maximum Speed (MAX) Adjustment	9
C. Minimum Speed (MIN) Adjustment	10
D. Current Limit (CL)/ Torque-Adjustment	10
E. IR-Comp (IR) Adjustment	10

Section	Page
V Trouble Shooting Guide	11
VI Internal Wiring Diagrams	13

LIST OF ILLUSTRATIONS

Figure	Page
1. MULTI-DRIVE [®] Versatility	3
2. Location of Features and Functions	5
3. Mounting Dimensions	7
4. Connection Diagram	8
5. ACCEL/DECEL Trimpot Adjustment	9

LIST OF TABLES

Table	Page
1. Nominal Trimpot Settings	2
2. Electrical Ratings	3
3. Plug-In Horsepower Resistor Chart	3
4. General Performance Specifications	5
5. Minimum Supply Wire Size Requirements	8



SAFETY WARNING—PLEASE READ CAREFULLY

This product should be installed and serviced by a qualified technician, electrician or electrical maintenance personnel familiar with its operation and the hazards involved. Proper installation which includes wiring, mounting in proper enclosure, fusing or other overcurrent protection and grounding, can reduce the chance of electric shocks, fires or explosion in this product or products used with this product, such as electric motors, switches, coils, solenoids and/or relays. Eye protection must be worn and insulated adjustment tools must be used when working with control under power. This product is constructed of materials (plastics, metals, carbon, silicon, etc.) which may be a potential hazard. Individual material safety data sheets (MSDS) are available upon request. Proper shielding, grounding and filtering of this product can reduce the emission of radio frequency interference (RFI) which may adversely affect sensitive electronic equipment. If information is required on this product, contact our factory. It is the responsibility of the equipment manufacturer and individual installer to supply this safety warning to the ultimate user of this product. (SW effective 7/89)

TABLE 4. GENERAL PERFORMANCE SPECIFICATIONS

Speed range (ratio)	50:1
Load regulation (% base speed) (0–full load; 50:1 speed range)	1*
Line voltage regulation (% base speed) (at full load; 100–130 VAC)	1/2*
Control linearity (% speed vs. dial rotation)	2
CL/torque range (% full load)	0–200
ACCEL/DECEL time period (0–full speed) (secs.)	.2–10
Min. speed trimpot range (% full speed)	0–30*
Max. speed trimpot range (% full speed)	50–110*
IR compensation trimpot range (at specified full load) (volts)	0–24
Maximum allowable ambient temperature at full rating (°C/°F)	50/122

*Performance is for SCR rated PM motors only. Lower performance can be expected with other motor types. Factory setting is for 3% load regulation. To obtain superior regulation, see Sec. IV E. (page 10). Other factory trimpot settings are as follows: CL-150% FL, ACCEL-2 secs., DECEL-2 secs., MIN-(0)-speed, MAX-full speed & IR-6 volts.

FIG. 2 LOCATION OF FEATURES AND FUNCTIONS

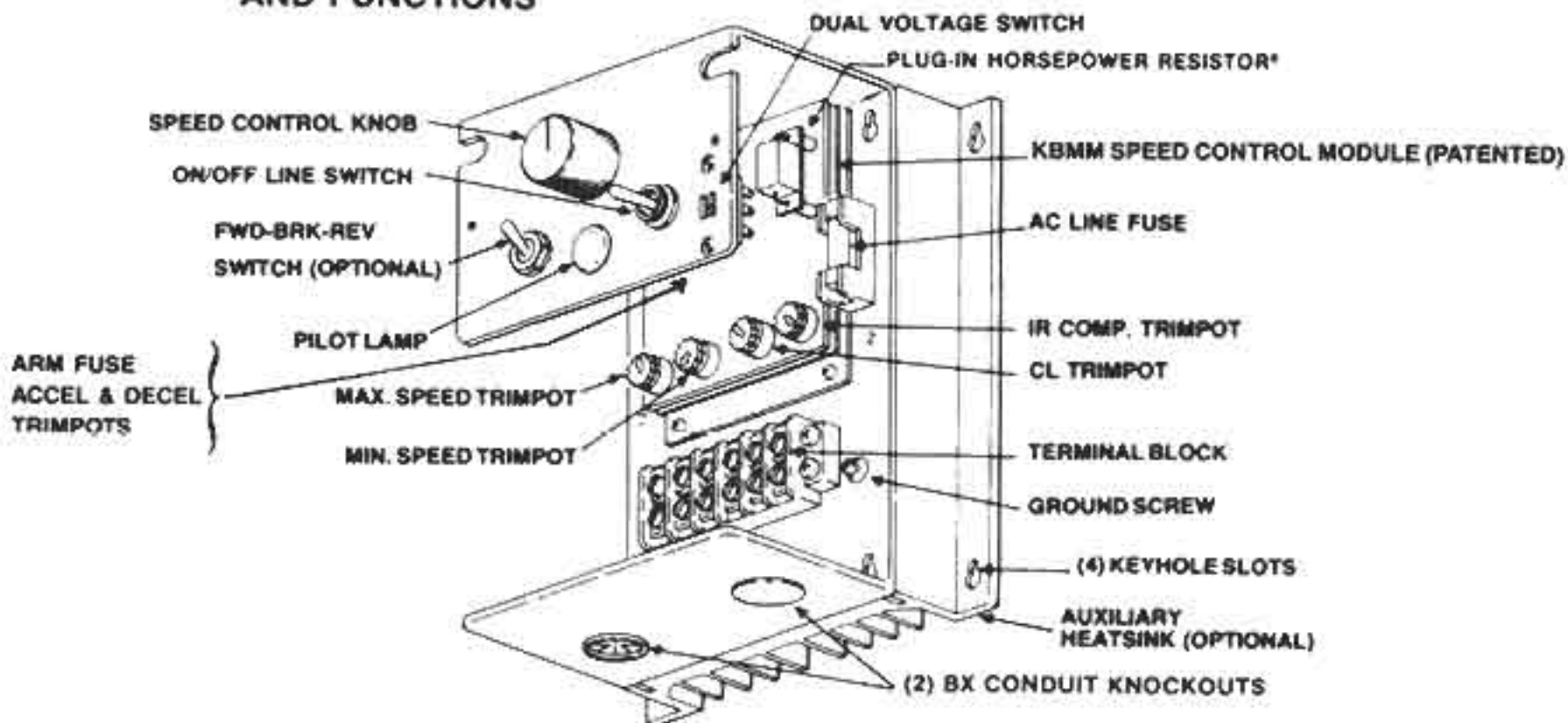

INTRODUCTION

The New Multi-Drive[®] Full Wave Solid State DC Motor Speed Control with the patented KBMM Speed Control Module represents the latest state-of-the-art design achievable through modern technology.

Features Include: Short circuit protection, CL LED Indicator, Auto Inhibit.

- **Integrated Circuitry**

Used to control and amplify command and reference levels with both closed and open loop feedback to provide superior motor regulation. (Speed changes due to load, line voltage, or temperature variations are held to minimum levels).

- **High Quality Components**

Selected and tested for proven dependability.

- **Transient Protection**

Used to prevent failure of the power bridge circuit caused by voltage spikes on the AC line.

- **High Reliability**

When used in accordance with the instructions included in this manual, the Multi-Drive[®] will provide years of trouble-free operation.

SECTION I. APPLICATION INFORMATION

A. Motor Type. Multi-Drive[®] is designed for Permanent Magnet (PM) and Shunt Wound D.C. motors. Controls operated on 120 volt AC inputs are designed for 90 volt SCR rated motors. Controls operated on 240 volt AC inputs are designed for 180 volt SCR rated motors. Use of higher voltage motors will result in degradation of full speed performance. Also, if motor is not an SCR rated type, the actual AC line amperage at full load should not exceed the motor's DC nameplate rating.

B. Torque Requirements. When replacing an AC induction motor with a DC motor and speed control, consideration must be given to the maximum torque requirements. The full load torque rating of the DC motor must be equal to, or greater than, that of the AC motor.

C. Acceleration Start. The Multi-Drive[®] contains an adjustable acceleration start feature which allows the motor to smoothly accelerate from 0–full speed over a time period of .2–10 seconds. The "ACCEL" is factory set at 2 seconds.

D. Limitations in Use. Multi-Drive[®] controls are designed for use on machine applications.

CAUTION: Consult factory before using on constant horsepower applications such as saws or drill presses. Do not use in explosive atmosphere.

CAUTION: Be sure the Multi-Drive[®] is used within its max. ratings. Follow all installation instructions carefully. (Refer to Section II.)

SECTION II. INSTALLATION INSTRUCTIONS

A. Location and Mounting. The Multi-Drive[®] control should be mounted on a flat surface and located in an area where it will not be exposed to contaminants such as water, metal chips, solvents, or excessive vibration.

When mounting in an airtight enclosure, the air space should be large enough to provide adequate heat dissipation. The maximum allowable ambient temperature at full rating is 50°C (122°F). Consult your factory representative if more information is required.

NOTE: Adequate clearance must be allowed to permit motor and power cables to enter through BX knockouts on bottom of control.

FIG. 3 MOUNTING DIMENSIONS (INCHES, MM)

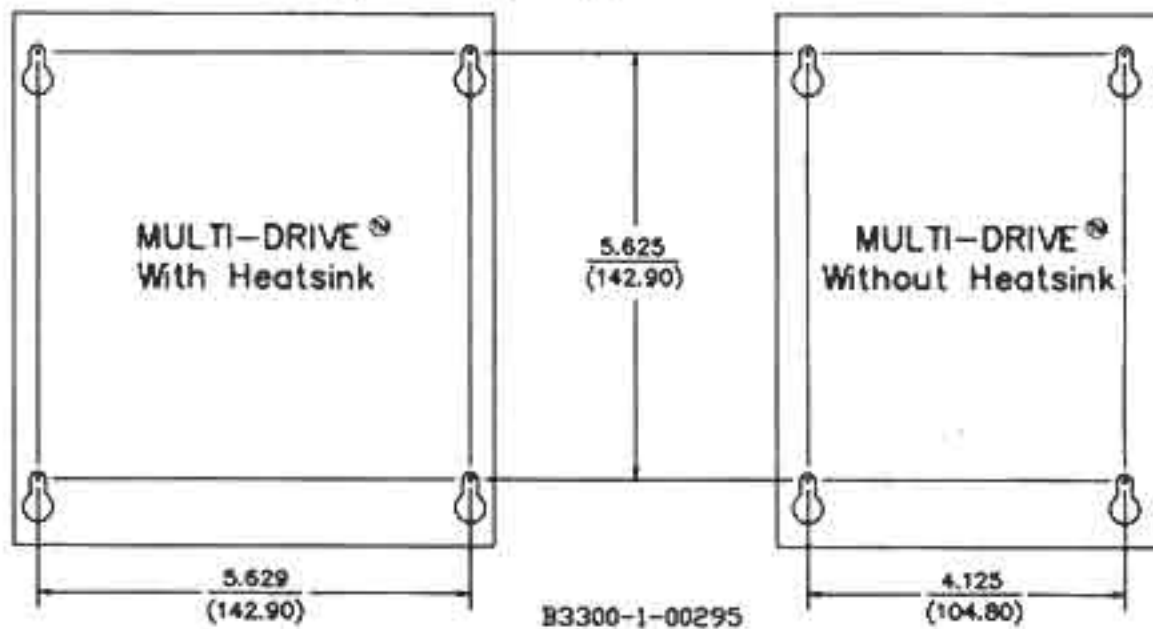

B. Initial Setup. WARNING: To prevent electrical shock turn power off before wiring.

- (1) Slide open front cover by removing two 6-32 screws.
- (2) Install Plug-In Horsepower Resistor[®] corresponding to motor voltage and horsepower. (See chart Table 3, page 3)
- (3) Set the Dual Voltage Switch to proper position "115" or "230" which corresponds to the nominal AC input line voltage 120 or 240 VAC.
- (4) Install proper Armature fuse according to Fuse Selection Chart. (Table 6, page 8)
- (5) Trimpots have been factory adjusted. If readjustment is required see section IV pages 9 & 10.
- (6) Install Auxiliary Heatsink if motor is larger than 3/4 HP on 120 VAC and 1-1/2 HP on 240 VAC. (Use (6) No. 10-32 screws)

C. Wiring. (See Fig. 4 for terminal arrangement and wiring information.)

- (1) Connect the Multi-Drive[®] to a standard 120 V or 240 V 50/60 Hz power source. [Be sure the DVS is set to the proper voltage "115" or "230" and motor voltage corresponds to the line voltage. (e.g. 90-130 VDC motor on 115-120 VAC and 180 VDC motor 230-240 VAC)]
- (2) Follow the recommended supply wire sizes as per Table 5. (For Stepdown operation see note on page 8.)
- (3) Follow the NEC and other appropriate electrical codes. **CAUTION:** Separate branch protection must be provided on 240 V circuits.
- (4) Replace front cover and the two 6-32 screws.

TABLE 5. MINIMUM SUPPLY WIRE SIZE REQUIREMENTS.

MAX. MOTOR AMPS (DC AMPS)	MAX. MOTOR HP 90 V	MAX. MOTOR HP 180 V	MINIMUM WIRE SIZE (AWG) Cu Only	
			MAX. 50 FOOT RUN	MAX. 100 FOOT RUN
8.0	3/4	1-1/2	16	14
11.0	1	2	14	12*

*Maximum recommended wire size

Application Note: Stepdown operation: The control can be set up for stepdown operation (e.g.: 90 VDC motors used with 240 VAC line input). If stepdown operation is required, the following procedure is used.

1. Place dual voltage switch in "115" position.
2. Cut out and remove the resistor R308 (large blue body) from the back of the dual voltage switch. For shunt wound motors only—connect motor field wires to F+ and L₁ terminals.

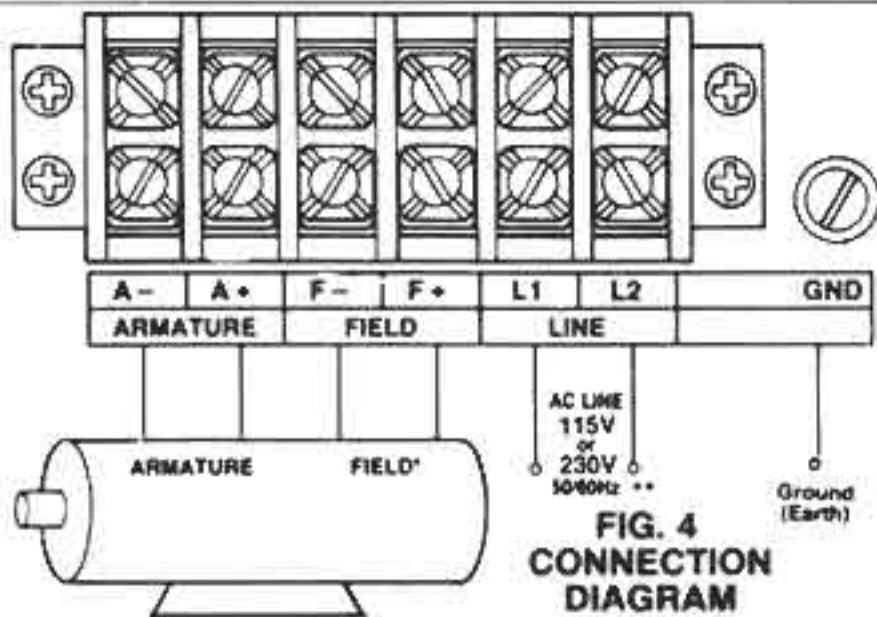

- * Use F- & F+ for shunt motors only. On motors with half voltage fields (e.g. 50 V field with 100 V rated armature) use L₁ & F+ terminals.
- ** Be sure to set the Dual Voltage Switch to the proper position "115" or "230".

TABLE 6. FUSE SELECTION CHART

90 VDC MOTOR HORSEPOWER	180 VDC MOTOR HORSEPOWER	APPROX. DC MOTOR CURRENT (AMPS)	FUSE RATING (AC AMPS) ARM	RECOM. RATING (AC AMPS) LINE
			1/30	1/15
1/20	1/10	.5	3/4	12
1/15	1/8	.65	1	12
1/12	1/6	.85	1-1/4	12
1/8	1/4	1.3	2	12
1/6	1/3	1.7	2-1/2	12
1/4	1/2	2.5	4	12
1/3	3/4	3.3	5	12
1/2	1	5.0	8	12
3/4	1-1/2	7.5	12	12
1	2	10.0	15	25

CAUTION: If control is wired to a transformer, it is advisable to switch the secondary to disconnect power. If the primary is switched, additional snubber capacitors may have to be added across the transformer output to prevent damage to the power bridge.

WARNING: Do not wire switch or relay in series with armature or catastrophic failure will result.

D. Fusing.

- (1) The Multi-Drive™ contains a built-in replaceable AC line fuse rated 20A-240 VAC. (Use Buss type MDA or equiv.) The AC line fuse protects the control against catastrophic failure. If the fuse blows, the control is miswired, the motor is shorted or grounded, or the Speed Control Module is defective. (Note: jumping of fuse will void warranty)
- (2) Armature Fuse—Provides motor overload protection. Armature fuses are available from your distributor. Fuse at approximately 1.7 times the D.C. amperage rating of the motor. (See Fuse Selection Chart)

SECTION III. OPERATION

1. Set ON/OFF power switch to "OFF".
2. Set speed control knob to "0".
3. Set FWD-BRK-REV switch (if installed) to "FWD".
4. Turn power switch to "ON" gradually increase speed control knob setting. Motor should come up to speed smoothly and remain stable. (NOTE: If control fails to operate, see Troubleshooting Guide, Section V, p. 11, 12)

SECTION IV. ADJUSTMENTS AND CONTROL FUNCTIONS

The Multi-Drive[®] has been factory adjusted to provide 0 to full speed range using the speed control knob. Minimum and maximum speed trimpots are provided to change the speed from other than 0 to full speed. An acceleration start trimpot is factory set to provide motor acceleration from 0 to full speed over a time period of 2 seconds (approx.) each time the AC power is applied. The current limiting (CL, or torque output) adjustment is factory set to approximately one and a half times the motor rating. The IR Compensation (IR) is factory adjusted to provide excellent motor regulation under normal operation.

NOTE: In order for the IR comp and CL trimpot settings to be correct, the proper Plug-In Horsepower Resistor[®] must be installed for the particular motor and input voltage being used. Do not attempt to change the settings of the trimpots unless absolutely necessary since they are factory adjusted to near optimum settings.

The following procedure, presented in order of adjustment sequence, should be used when readjusting all trimpot functions:

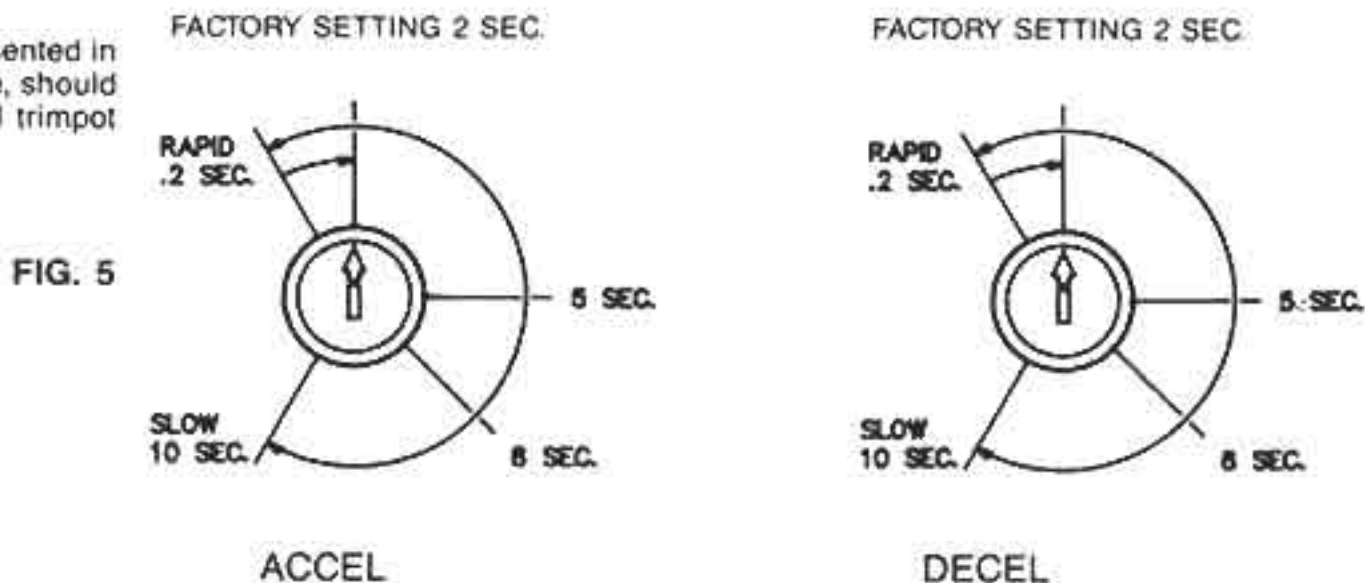

- Acceleration Start and Deceleration.** ACCEL and DECEL trimpots are located on the left side of the speed control module. If the ACCEL and/or DECEL are to be readjusted to different times, adjust trimpots according to Figure 5.
- Maximum Speed Adjustment.** Turn Speed Control Knob to full speed (maximum CW position). Adjust max. speed trimpot to new desired setting.

NOTE: Do not attempt to adjust the max. speed above the rated motor RPM since unstable motor operation may occur. For moderate changes in the max. speed, there will be a slight effect on the min. speed setting when the min. speed is set at zero. There may be significant variation in the min. speed setting if the min. speed is at a higher than zero setting.

- C. Minimum Speed Adjustment.** If a higher than zero minimum speed is desired, readjust the minimum speed by turning the speed control knob to zero setting (full CCW position). Then adjust the Min. Speed Trimpot to the desired setting.

NOTE: The min. speed adjustment will affect the max. speed setting. Therefore, it is necessary to re-adjust the max. speed after the min. speed, and it may be necessary to repeat the sequence until both the min. and max. speeds are set to the desired levels.

- D. Current Limit (CL/Torque Adjustment).** CL circuitry is provided to protect the motor and control against overloads. The CL also limits the inrush current to a safe level during startup. The CL is factory set to approximately 1.5 times the full load rating of the motor. (CL trimpot is nominally set to approx. 75% of full CW rotation.) CL LED will light when control is in current limit.

NOTE: The correct value Plug-In Horsepower Resistor* must be installed in order for the CL and IR comp. to operate properly.

To set the CL to factory specifications adjust as follows:

1. Set speed control knob at approximately 30–50% CW rotation. Set CL trimpot to full CCW position.
2. Connect a DC ammeter in series with the armature lead.
3. Lock shaft of motor (be sure CL pot is in full CCW position). Apply power and rotate CL pot CW slowly until DC ammeter reads 1.5 times motor rating (do not exceed 2 times motor rating).

- E. IR Compensation Adjustment.** IR compensation is provided to substantially improve load regulation. If the load presented to the motor does not vary substantially, the IR adjustment may be set at a minimum level (approximately 1/4 of full setting). The control is factory adjusted to approximately 3% regulation if superior performance is desired (less than 1% speed change of base speed from 0 to full load), then the IR comp should be adjusted as follows:

NOTE: Excessive IR comp. will cause control to become unstable, which causes motor cogging.

1. Set IR comp. trimpot at approximately 25% of CW rotation. Run motor unloaded at approximately 1/3 speed and record RPM.
2. Run motor with maximum load and adjust IR comp. trimpot so that the motor speed under load equals the unloaded speed per step 1.
3. Remove load and recheck unloaded RPM. If unloaded RPM has shifted, repeat procedure for more exact regulation.

The MULTI-DRIVE™ is now compensated to provide minimal speed change under large variations of applied load.

SECTION V. TROUBLESHOOTING GUIDE

The following Troubleshooting Guide is intended for use by a qualified technician. The Guide is designed to isolate common malfunctions of the MULTI-DRIVE[®] and/or motor. It should be used with the parts lists and schematics contained in this manual.

SYMPTOM

POSSIBLE CAUSE

CORRECTIVE ACTION

- | | | |
|---|--|--|
| 1. Motor does not run; power ON indicator not lit. | 1. Power switch in OFF position, or AC voltage not brought to L ₁ , L ₂ terminals. | 1. Move power switch to ON position. Correct wiring to control. |
| | 2. Blown line fuse. | 2. Replace line fuse with 20A rated 3AB-type fuse. If fuse blew due to miswiring, speed control module may be defective. |
| | 3. Defective power switch. | 3. Replace power switch. |
| 2. Motor does not run; power ON indicator lit. | 1. Speed control knob set to 0. | 1. Turn knob CW to start motor. |
| | 2. Defective motor. | 2. Check for defective motor, worn brushes, etc. Replace motor. |
| | 3. Plug-in Horsepower Resistor [®] not installed. | 3. Install proper Plug-in Horsepower Resistor [®] |
| | 4. Blown armature fuse. | 4. Replace fuse with proper value. |
| 3. Motor hums, or runs at very low speed (with control knob set at high number) or motor slows down substantially when load is applied. | 1. Low voltage. | 1. Check line voltage at control and rewire as required. |
| | 2. Overload condition; control in current limit mode (CL trimpot not set correctly). (CL LED lit) | 2. Reduce loading; CL trimpot setting may have to be increased. See Section IV. |
| | 3. Plug-in Horsepower Resistor [®] not correct size. | 3. Install proper size Plug-In Horsepower Resistor [®] |
| | 4. Incorrect wiring. Armature and shunt connections interchanged (shunt motor only). | 4. Correct wiring (armature has lower resistance than field). |

SECTION V. TROUBLESHOOTING GUIDE

SYMPTOM

POSSIBLE CAUSE

CORRECTIVE ACTION

4. Erratic motor performance.

1. Defective motor, worn brushes, etc.

1. Repair motor.

2. Overload condition.

2. Remove overload.

3. Plug-in Horsepower Resistor*
wrong size.

3. Replace Plug-in Horsepower
Resistor* with proper size.

4. IR comp and/or CL trimpots not
set properly.

4. Readjust trimpots as per Section IV.

5. Defective speed control module.

5. Replace module.

6. Dual Voltage Switch set in wrong
position.

6. Recheck line voltage and set Dual
Voltage Switch to proper position
"115" or "230".

5. Motor continues to run when speed
control knob is set to 0.

1. Min. speed trimpot not set to full
CCW position.

1. Readjust min. trimpot.

2. IR comp trimpot set too high.

2. Lower IR comp trimpot setting.

6. Motor runs in wrong direction.

1. Armature leads reversed.

1. Reconnect armature leads.

The following portion of the Troubleshooting Guide refers only to controllers that have the FWD-BRK-REV switch option.

SYMPTOM

POSSIBLE CAUSE

CORRECTIVE ACTION

1. Motor will not run in either forward
or reverse direction.

1. Faulty wiring or loose connections
to reversing switch.

1. Correct wiring (see internal wiring
diagram).

2. Defective FWD-BRK-REV switch.

2. Replace switch assembly.

2. No braking action in brake mode.

1. Faulty wiring or loose connection.

1. Correct wiring.

2. Faulty FWD-BRK-REV switch.

2. Replace switch assembly.

3. Defective Brake Resistor.

3. Replace resistor.

SECTION VI. (A) INTERNAL WIRING DIAGRAMS

1. BASIC MULTI-DRIVE[®]

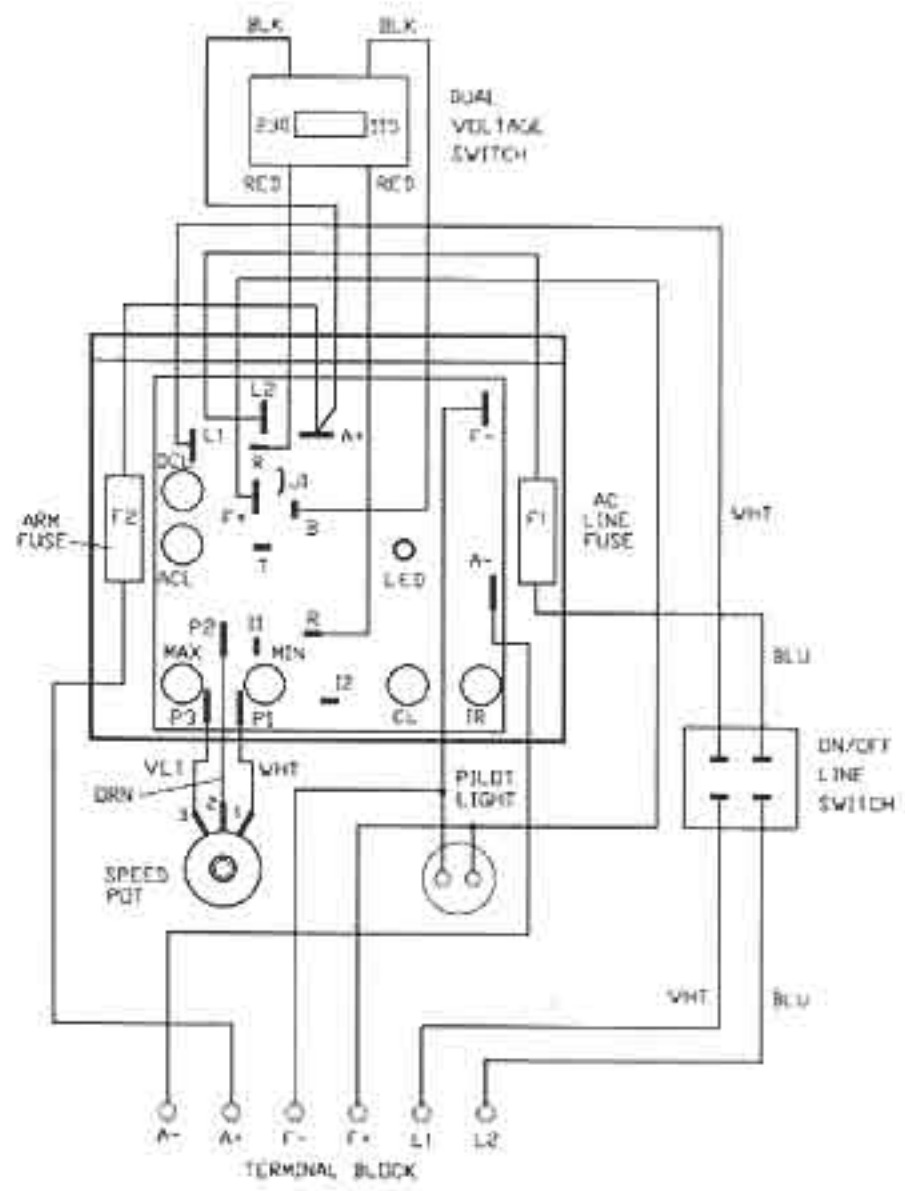

2. FORWARD-BRAKE-REVERSE SWITCH (OPTIONAL)

