

KBMG-212D

ULTRACOMPACT REGENERATIVE DRIVE

FULL-WAVE • 4-QUADRANT
SCR Variable Speed and Torque Control for
PM and Shunt Motors

ONE MODEL COVERS:

1/10 – 1HP (90VDC) @ 115VAC – 50/60 Hz
1/5 – 2HP (180VDC) @ 230VAC – 50/60Hz

- Conveyors • Indexers • Feeders • Positioners
- Textile Equipment • Packaging Machinery
- Web Control • Converting Machinery

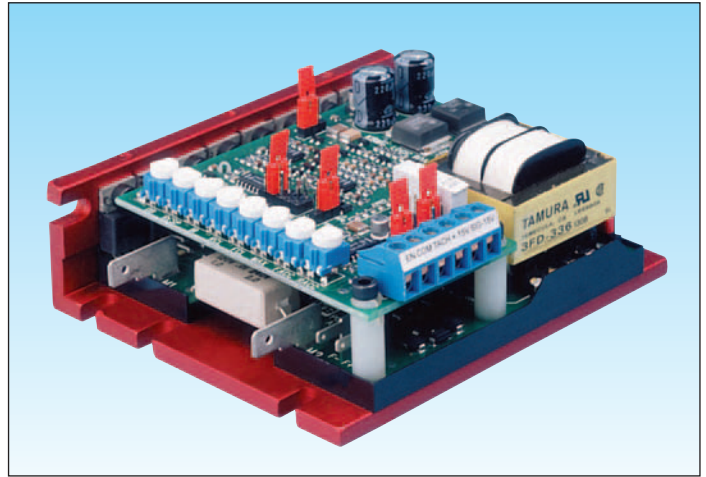

STANDARD FEATURES

• Jumper Selectable Features

Operation Mode: Speed, Torque
AC Line Voltage (VAC– 50/60 Hz): 115, 230
DC Armature Voltage (VDC): 90, 180
Tach-generator Voltage (VDC): 7, 50
DC Current Output (ADC): 1.7, 2.5, 5.0, 7.5, 10*
Analog Input Voltage (VDC): 0 – 10, 0 – 15
Enable: Coast to Stop (CTS), Regenerate to Stop (RTS)

• Trimpot Adjustments

Dead Band (DB) • Response (RESP) • IR Compensation (IR)
Forward Current Limit (FCL) • Reverse Current Limit (RCL)
Maximum Speed (MAX) • Forward Acceleration (FACC)
Reverse Acceleration (RACC)

• LED's

Power On (PWR ON) • Overload (OL)

SPECIFICATIONS

AC Line Input Voltage (VAC $\pm 10\%$ 50/60 Hz)	115 or 230
AC Line Frequency (Hz)	50/60
Armature Voltage Range 115VAC Line (VDC)	0 – ± 90
Armature Voltage Range 230VAC Line (VDC)	0 – ± 90 , 0 – ± 180
Field Voltage at 115VAC Line (VDC)	100/50
Field Voltage at 230VAC Line (VDC)	200/100
Max Load Capacity (% for 2 Minutes)	150
Ambient Temperature Operating Range ($^{\circ}\text{C}$)	0 – 50
Speed Range (Ratio)	50:1
Armature Feedback Load Regulation (% Base Speed)	± 1
Tach-generator Feedback Load Regulation (% Set Speed)	± 1
AC Line Regulation (% Base Speed)	± 0.5
Current Ranges (Amps DC)	1.7, 2.5, 5.0, 7.5, 10*
Forward Accel (FACC) and Reverse Accel (RACC) Range (Sec.)	0.1 – 15
Dead Band Range (% Base Speed)	0 – ± 5
Max Speed Trimpot Range (% Base Speed)	55 – 110
IR Comp Range at 115VAC Line (VDC @ Full Load)	0 – 20
IR Comp Range at 230VAC Line (VDC @ Full Load)	0 – 40
Forward CL (FCL) and Reverse CL (RCL) Range (% Range Setting)	0 – 175
Voltage Following Input Range (VDC)**	0 – ± 10 , 0 – ± 15
Voltage Following Linearity (% Base Speed)	± 0.5

* Requires Auxiliary Heatsink KB P/N 9861

** Requires isolated input or signal isolator

DESCRIPTION

The KBMG is an ultracompact, full-wave regenerative drive capable of operating DC PM or Shunt motors in a bidirectional mode. Its 4-quadrant operation provides forward and reverse torque in both speed directions. This allows the control to maintain constant speed with overhauling loads and provides rapid reversing and controlled braking. Because of its excellent controllability and response time, the KBMG can replace servos in many applications. The control is factory set for armature feedback, which provides up to 1% load regulation over a motor base speed of 50:1. Tach-generator feedback is also provided for superior load regulation if required. A simple jumper setting converts the KBMG to a torque control. In this mode, motor torque rather than motor speed is controlled.

An important feature of the drive is the factory-calibrated, built-in, selectable motor current jumper. It eliminates the need to recalibrate IR Comp and Current Limit for most applications.

The control contains an Enable function that can be used to start and stop the motor electronically via a contact closure. Through a jumper selection, the motor can be controlled to rapidly “regenerate to stop” or to “coast to stop.”

KB's exclusive Auto Inhibit[®] circuit provides safe, smooth starting even during rapid cycling of the AC line. The Overspeed Protect Circuit prevents failure of the power bridge in extreme overhauling conditions. Reliability of the KBMG is further enhanced with the use of a high speed current limit circuit and MOV transient protection. LED's, which can be used for diagnostics, are provided for power on and motor overload. A rugged extruded aluminum heatsink ensures enhanced heat transfer, which provides a higher control rating while maintaining cooler running SCR's.

Power connections to the KBMG are made via quick connect terminals and signal input connections are made via a removable barrier terminal block.

A 5K remote potentiometer and full operating instructions are supplied.

OPTIONAL FEATURES

- **SIMG Bipolar Signal Isolator (P/N 8832)** – Allows a nonisolated signal source to be used.
- **Multi Speed Board (P/N 8833)** – Provides discrete preset speeds which can be controlled from a PLC.
- **4-Quadrant Accel/Decel (P/N 8834)** – Provides independent settings of forward accel, forward decel, reverse accel and reverse decel.
- **DIN Rail Mounting Kit (P/N 9995)** – Converts control to standard DIN Rail Mounting.

ELECTRICAL RATINGS

Model Number	KB Part Number	AC Line Voltage (VAC) $\pm 10\%$ 50/60 Hz	Motor Voltage (VDC)	Rating Without Auxiliary Heatsink			Rating With Auxiliary Heatsink		
				Max. AC Line Current (RMS Amps)	Max. DC Load Current (Avg. Amps)	Maximum Horsepower HP, (KW)	Max. AC Line Current (RMS Amps)	Max. DC Load Current (Avg. Amps)	Maximum Horsepower HP, (KW)
KBMG-212D	8831	115	0 – ± 90	12.0	8.0	0.75, (0.5)	16.0	11.0	1, (0.75)
		230	0 – ± 180	12.0	8.0	1.5, (1.0)	16.0	11.0	2, (1.5)

CONNECTION DIAGRAMS

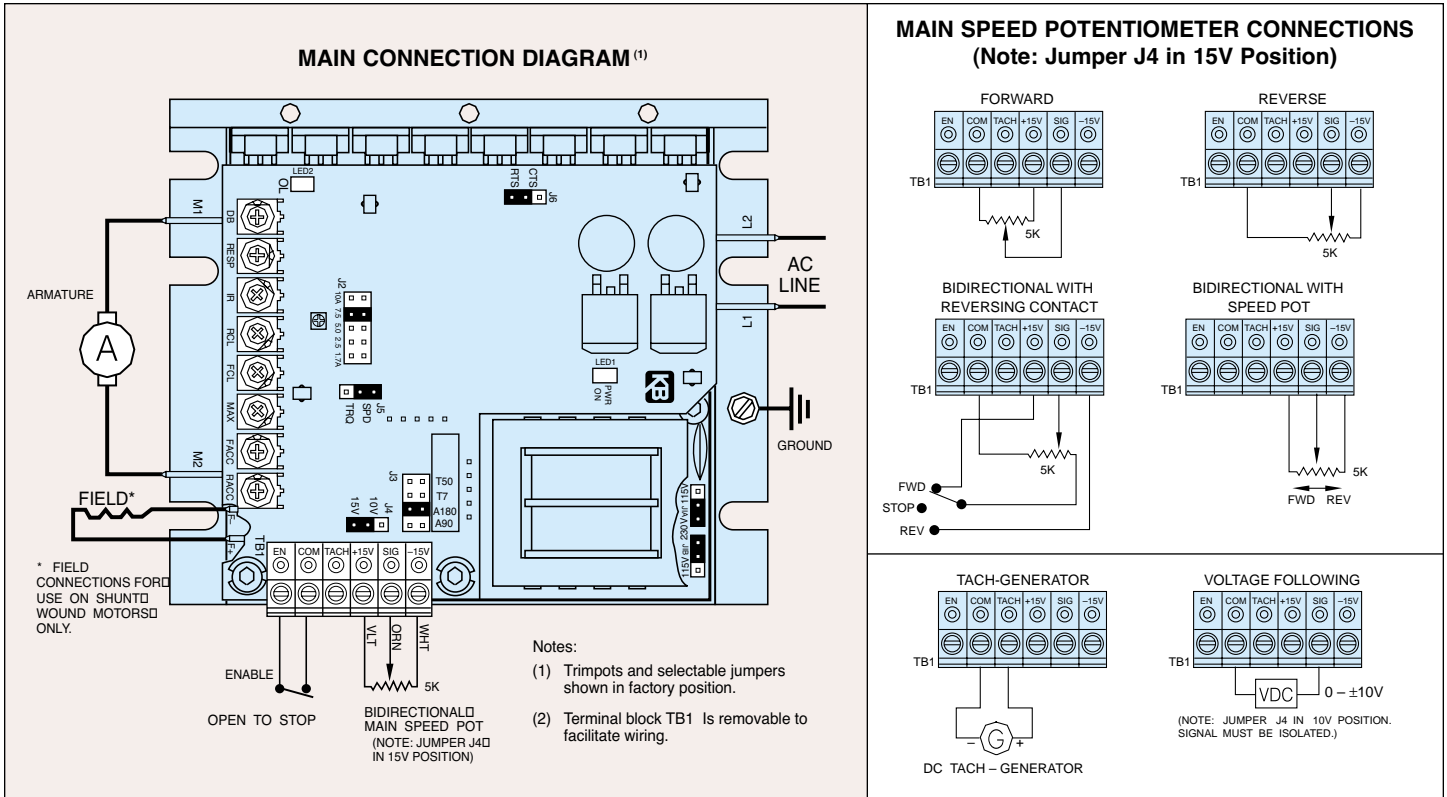

MECHANICAL SPECIFICATIONS INCHES [mm]

