

KBPC-225

PENTA DRIVE™

NEMA-4X, IP-65

Variable Speed-Torque SCR DC Motor Control
for Shunt Wound and PM DC Motors

RATED – 3 Hp @ 230 VAC – 50/60 Hz

Washdown and Watertight
for Indoor and Outdoor Use



STANDARD FEATURES

- Electronic Overload Protection
- LED's for "Power On," "Overload" and "Stop"
- Electronic Start-Stop

JUMPER SELECTABLE FEATURES

- Control Mode: Speed, Torque
- Feedback Type: Armature, Tachometer
- Tachometer Voltage[▲] (VDC): 7, 20/30, 50
- Timed Current Limit: TCL, NTCL

Bold figure indicates factory setting. [▲] Per 1,000 RPM

TRIMPOT ADJUSTMENTS

- Minimum speed (MIN)
- Current Limit (CL)
- Acceleration (ACCEL)
- Timed Current Limit (TCL)
- Maximum Speed (MAX)
- IR Compensation (IR)
- Deceleration (DECEL)
- Jog Speed (JOG)[▲]

[▲] Used with Run-Stop-Jog option.

OPTIONAL FEATURES

- Forward-Brake-Reverse Switch (P/N 9339)
- Signal Isolator, KBSI-240D (P/N 9431)
- Run-Stop-Jog Switch (P/N 9340)
- White Case (FDA) (P/N 9392)
- Auto/Manual Kit (P/N 9377)

SPECIFICATIONS

AC Line Input (VAC ± 15%, 50/60 Hz)	230
Horsepower at 230 VAC Line (Hp) [KW]	3 [2.25]
Armature Voltage Range at 230 VAC Line (VDC)	0 - 200(1)
Field Voltage at 230 VAC Line (VDC)	200/100(2)
Ambient Temperature Range (°C)	0 - 45
Speed Range (Ratio)	50:1(3)
Load Regulation [Armature Feedback] (% Base Speed)	±1
Load Regulation [Tachometer Feedback] (% Set Speed)	±1
AC Line Voltage Regulation (% Base Speed)	±0.5
ACCEL and DECEL Ranges (Seconds)	0.1 - 15

DESCRIPTION

The KBPC Series NEMA-4X (IP-65) SCR DC Motor Speed and Torque Control is designed for applications requiring washdown watertight integrity. Its housing is ruggedly constructed of die cast aluminum which is protected with an acrylic coating for the ultimate in corrosion resistance. All switches are sealed with rubber boots and the main speed potentiometer contains a shaft seal.

The KBPC state-of-the-art electronics include short circuit and transient protection to provide the ultimate in reliability. Electronic overload protection is also provided, which prevents motor burnout and demagnetization of PM motors. The control can be operated in either the speed or torque mode via a jumper selection. The KBPC contains jumper selections for feedback type (armature/ tachometer).

Standard features include Electronic Start/Stop and LED Indicator Array for "Power On," "Stop" and "Overload."

Although the KBPC is factory set for most applications, a variety of trimpots allow adjustment of the following parameters: MIN and MAX speed, Acceleration, Deceleration, Current Limit, IR Comp, and Timed Current Limit. The drive offers the ultimate in flexibility with the availability of several customer installed options. These include: Forward-Brake-Reverse (one cycle per minute), Run-Stop-Jog, Input Signal Isolation, and Electronic Potentiometer. A complete instruction manual is included.

MIN SPEED Range (% Base Speed)	0 - 30
MAX SPEED Range (% Base Speed)	60 - 120
IR COMP Range at 230 VAC Line (VDC)	0 - 30
CL Range (% Range Setting)	0 - 180
Timed CL Range (Seconds)	0.5 - 15
Voltage Following Linearity (% Base Speed)	±0.5

1. Maximum recommended output voltage is 180 VDC at 230 VAC. Exceeding this output voltage will cause a reduction in load regulation performance.
2. For shunt wound motor with lower field voltage, use F1 and L1 connection.
3. Consult motor manufacturers for constant torque speed range of motor. (Typical speed range for most 3 Hp motor is 20:1.)

* CE Compliance Requires KBRF-200A RFI Filter



ELECTRICAL RATINGS

Model Number	KB Part Number	Input Line Voltage (VAC-50/60Hz)	Armature Voltage (VDC)	Maximum AC Load Current (RMS Amps)	Maximum DC Load Current (DC AMPS)	Maximum Power Hp (KW)
KBPC-225	9391 (Black)	230	0 – 180	22	15	3 (2.25)
	9392 (White)					

MECHANICAL SPECIFICATIONS INCHES [mm]

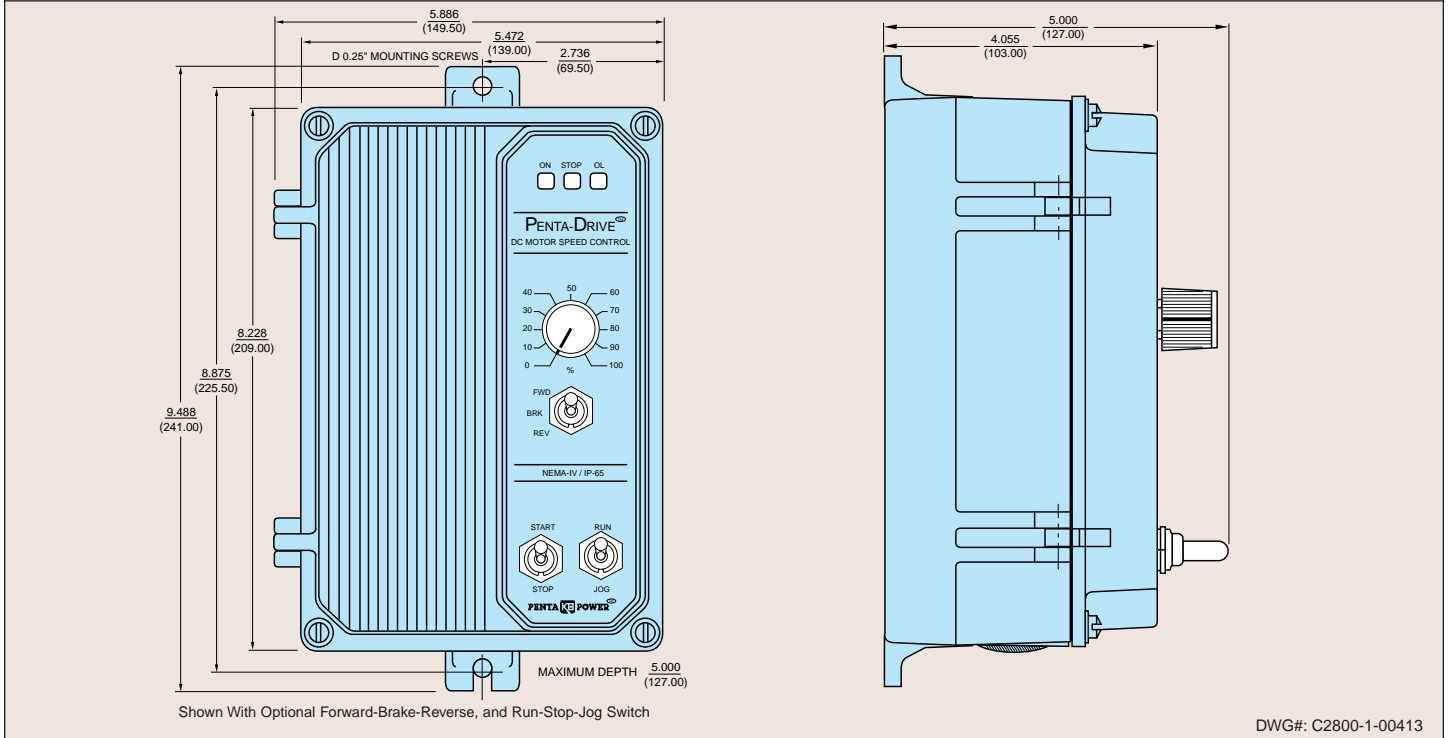

INTERNAL CONNECTION DIAGRAM

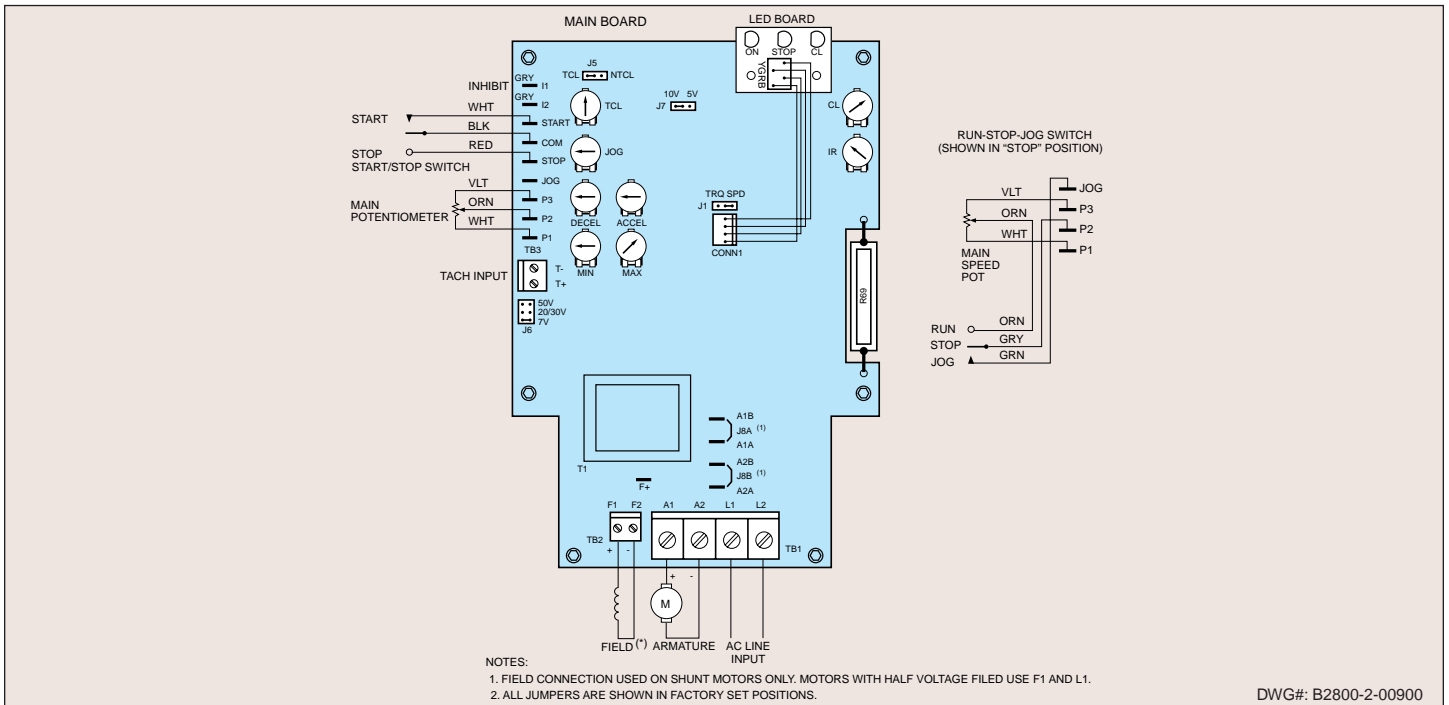

© 1998 KB Electronics, Inc.



KB ELECTRONICS, INC.
 12095 NW 39th Street, Coral Springs, FL 33065-2516
 (954) 346-4900 • FAX (954) 346-3377
 Outside Florida Call TOLL FREE (800) 221-6570
 www.kbelectronics.com