



"The Right Control
for Your Application"

Spec Tech Industrial 203 Vest Ave. Valley Park, MO 63088 Phone: 888 SPECTECH

Email: sales@spectechind.com

www.spectechind.com

DATA SHEET D-270

KBPI SERIES

NEMA-4X, IP-65

Indexing and Cycling SCR Controls for PM DC Motors

1/6 – 1 HP at 90 VDC, 1/3 – 2 HP at 180 VDC

MODEL KBPI-240D (Unidirectional)
KB Part No. 8500

MODEL KBPI-240DR (Reversing)
KB Part No. 8501



DESIGNED FOR INDEXING APPLICATIONS

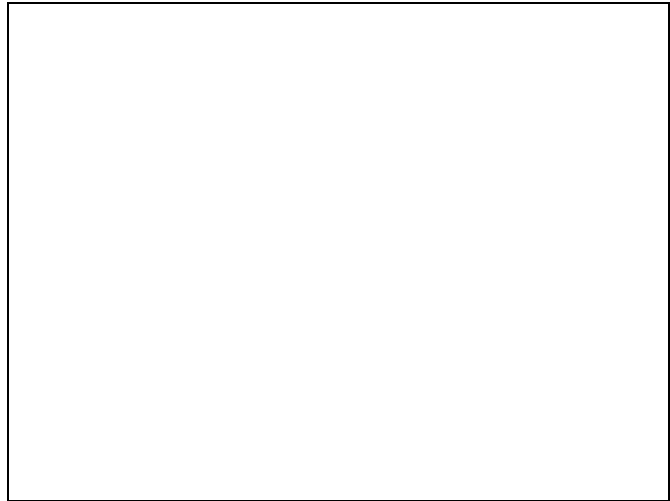

STANDARD FEATURES

- LED's for "Power On," Stop and Overload (OL)
- Electronic Start/Stop
- Adjustment Trimpots:
Minimum Speed (MIN), Maximum Speed (MAX)
Current Limit (CL), IR Compensation (IR)
- Built-in Armature Fusing

JUMPER SELECTABLE FEATURES

- AC Line Voltage (VAC – 50/60 Hz): 115/230
- DC Armature Voltage (VDC): 90/180
- DC Current Output (Amps DC): 2 / 3.3 / 5 / 10
- Stop Function Contact: NO / NC
- Run/Stop Priority: Stop / Run

SPECIFICATIONS

AC Line Input (VAC ± 10%, 50/60 Hz)	115, 230
Horsepower Range at 115 VAC Line	
(HP) [KW]	1/6 – 1 [.12 – .75]
Horsepower Range at 230 VAC Line	
(HP) [KW]	1/3 – 2 [.25 – 1.5]
Armature Voltage Range at 115 VAC Line (VDC)	0 – 100
Armature Voltage Range at 230 VAC Line (VDC)	0 – 200
Current Ranges (ADC)	2, 3.3, 5, 10
CL Trimpot Range (% Range Setting)	0 – 170
MIN Speed Trimpot Range (% Base Speed)	0 – 30
MAX Speed Trimpot Range (% Base Speed)	60 – 120
IR Comp Trimpot Range (VDC)	0 – 30
Speed Range (Ratio)	50:1
AC Line Voltage Regulation (% Base Speed)	± 0.5
Voltage Following Linearity (% Base Speed)	± 0.5
Load Regulation (% Base Speed)	± 1
Ambient Temp Range (EC)	0 – 45
Potentiometer, Front Cover (Ohms ÷ Watts)	5K – 1/3
Maximum Run/Stop Operations (Ops/Min)	30
Enclosure Type (NEMA)	4X

* CE Compliance Requires KBRF-200 RFI Filter.

DESCRIPTION

The KBPI INDEXER controls are packaged in a Nema 4X enclosure, which is ruggedly constructed of die cast aluminum. The controls are designed specifically for cycling and indexing applications.

Two models are offered which provide the choice of uni-directional or reversing operation. Both models can operate with either 115 or 230 VAC and with 90 or 180 VDC motors (proper jumper settings are required). The controls provide the user with *isolated* logic functions: STOP, JOG and RUN.

Other functions, such as cycle on demand, can easily be obtained. Another feature of the control is jumper J1 which is used for DC current selection. It automatically presets the IR Compensation and Current Limit for safe operation on various motors. Standard features include built-in armature fusing and an LED indicator array for "power on," "stop" and "overload." Model number KBPC-240DR also contains logic input for "Reverse Run" and "Reverse Jog."

The controls contain trimpots that can be used to readjust Minimum and Maximum speed, Current Limit and IR Compensation. The front panel contains a built-in 5K ohm speed potentiometer and a Run, Jog/Stop switch. Included with each control is a detailed instruction and user manual.

TOTAL INDEXING PERFORMANCE

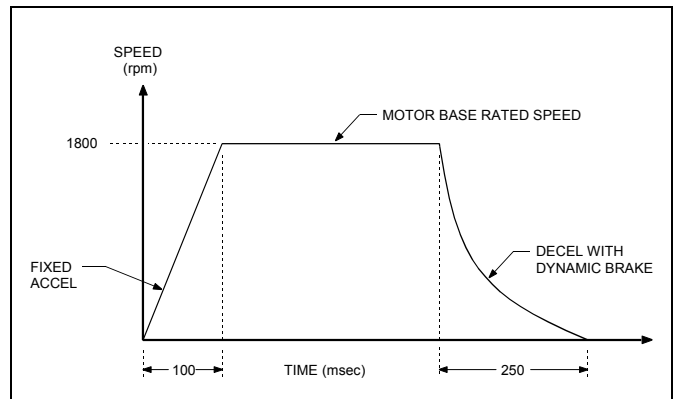

SPECIFICATIONS

Model Number	KB Part Number	AC Line Voltage (VAC) ±10% 50/60 Hz	Motor Voltage (VDC)	Max. AC Load Current (RMS Amps)	Max. DC Load Current (DC Amps)	Maximum Horsepower HP, (KW)	Type of Operation	Logic Provided
KBPI-240D	8500	115	0 – 90	15	10.2	1, (.75)	Unidirectional	Run, Jog, Stop, Rtn
		230	0 – 180	15	10.2	2, (1.5)	Unidirectional	Run, Jog, Stop, Rtn
		230	0 – 90	15	10.2	1, (.75)	Unidirectional	Run, Jog, Stop, Rtn
KBPI-240DR	8501	115	0 – 90	15	10.2	1, (.75)	Reversing	Fwd Run, Fwd Jog, Stop, Rev Run, Rev Jog, Rtn
		230	0 – 180	15	10.2	2, (1.5)	Reversing	Fwd Run, Fwd Jog, Stop, Rev Run, Rev Jog, Rtn
		230	0 – 90	15	10.2	1, (.75)	Reversing	Fwd Run, Fwd Jog, Stop, Rev Run, Rev Jog, Rtn

MECHANICAL SPECIFICATIONS INCHES [mm]

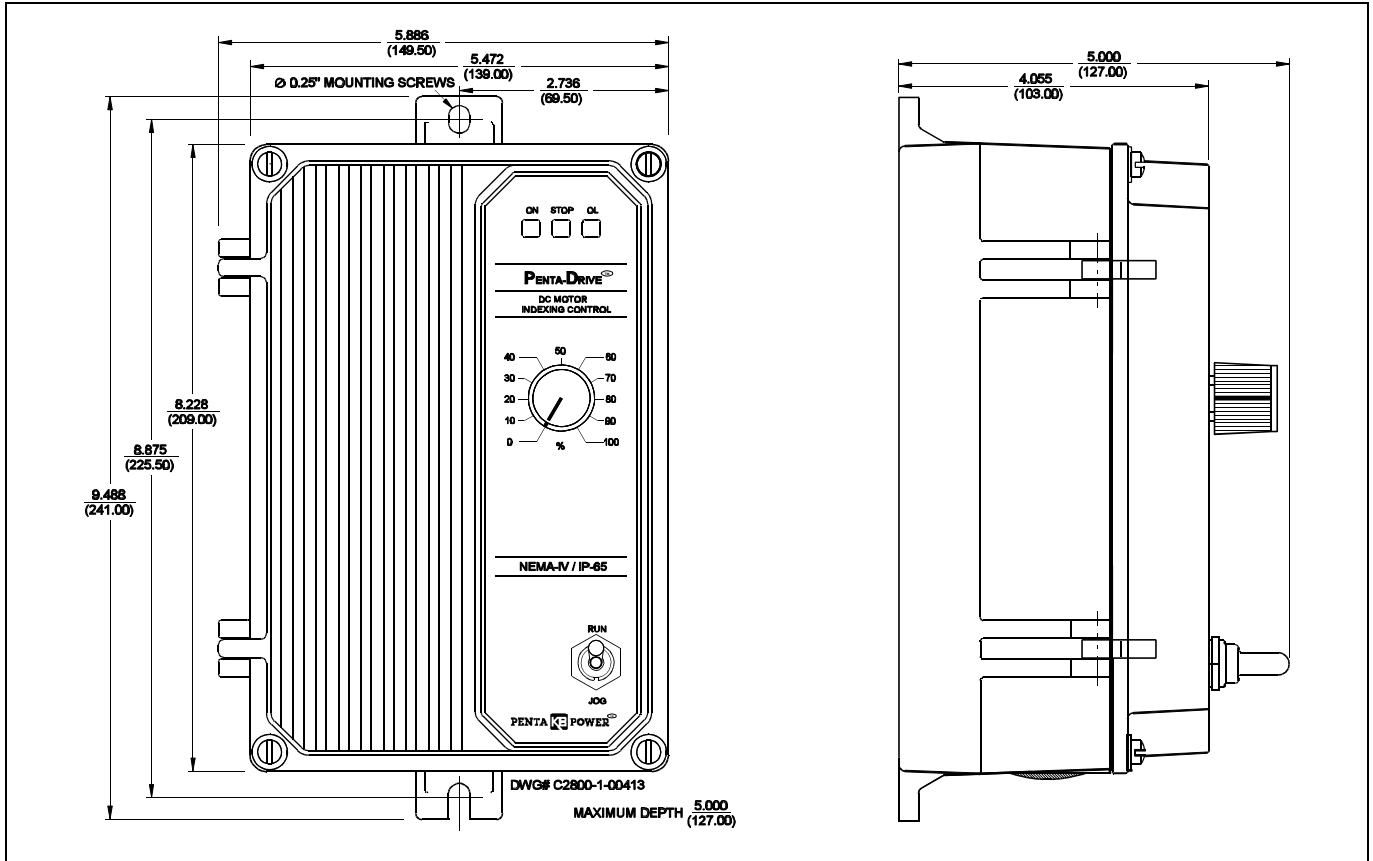

CONNECTION DIAGRAMS

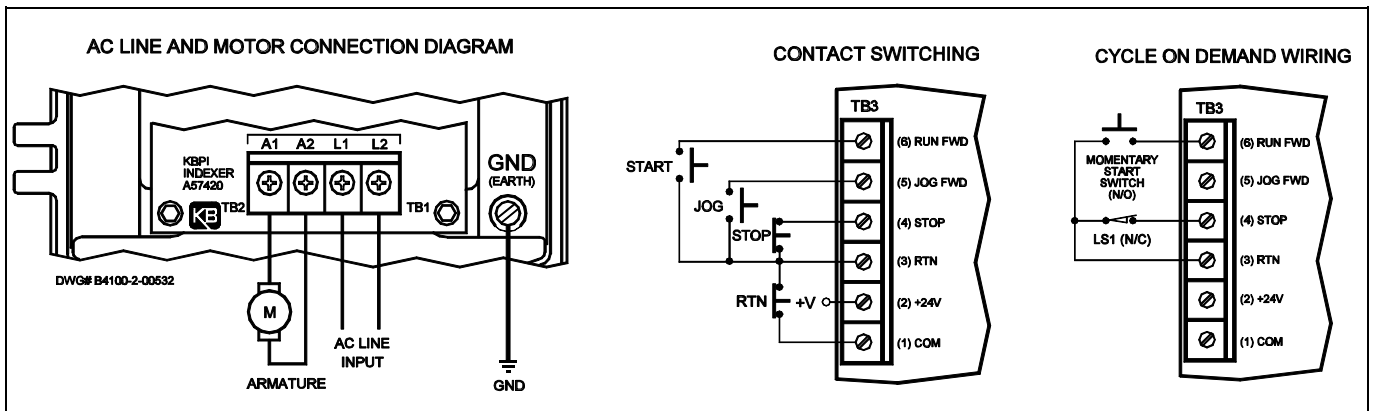

KB ELECTRONICS, INC.
 12095 NW 39th Street, Coral Springs, FL 33065 • (954) 346-4900 • Fax (954) 346-3377
 Outside Florida Call **TOLL FREE** (800) 221-6570 • Email – info@kbelectronics.com
 www.kbelectronics.com