

# INSTALLATION AND OPERATING INSTRUCTIONS

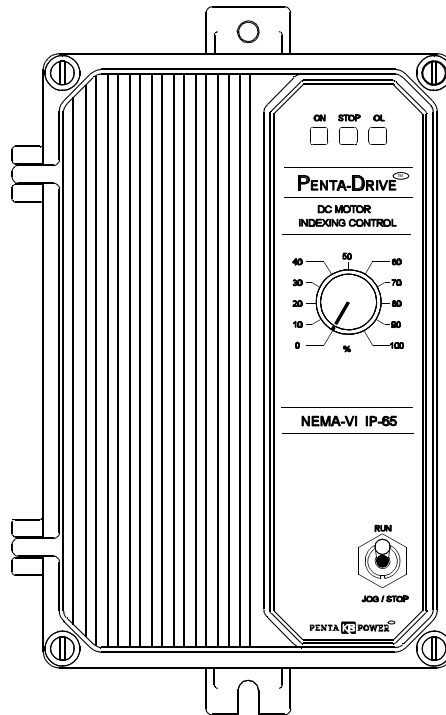
## KBPI<sup>TM</sup> SERIES

### SCR INDEXING & CYCLING CONTROLS

— Designed for Indexing Applications —

#### FOR PM DC MOTORS RATED

(1/6 – 1 HP @ 90VDC) and (1/3 – 2 HP @ 180VDC)



This control will not operate without installing the correct armature fuse – supplied separately.



See Page 2



#### This Manual Covers the Following Models

Model No.	Operation	Part No.
KBPI-240D	Unidirectional	8500
KBPI-240DR	Reversible	8501



See Safety Warning on Page 2

The information contained in this manual is intended to be accurate. However, the manufacturer retains the right to make changes in design which may not be included herein.

## PENTA **KB** POWER<sup>TM</sup>

A COMPLETE LINE OF MOTOR DRIVES

© 1998 KB Electronics, Inc.

## TABLE OF CONTENTS

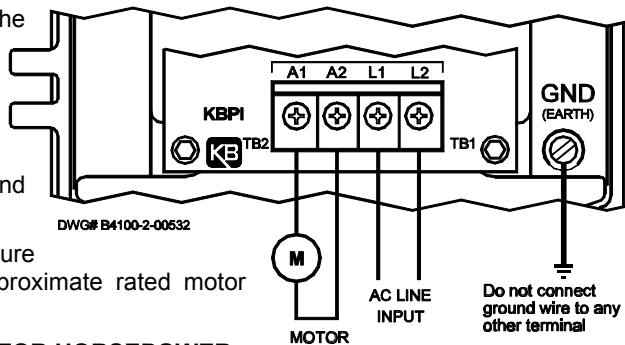
<u>Section</u>	<u>Page</u>
i. Simplified Setup and Operating Procedures .....	1
ii. Safety Warning .....	2
I. General Information .....	2
II. Mounting .....	7
III. Setting AC Line and Motor Voltage .....	9
IV. Setting Motor Current (Jumper J1) .....	9
V. Wiring .....	10
VI. Fusing .....	11
VII. Logic Functions and Wiring .....	12
VIII. Application Wiring Diagrams .....	14
IX. Application Wiring Diagrams, Reversible Models .....	17
X. Operation .....	18
XI. Trimpot Adjustments .....	18
XII. Function Indicator Lamps .....	19
XIII. Troubleshooting Guide .....	20
XIV. Limited Warranty .....	30
 <b><u>TABLES</u></b> 	
1. Electrical Ratings .....	3
2. General Performance Specifications .....	6
3. Selectable Jumper Reference Chart .....	7
4. Relationship of AC Line Input and Motor Voltage with Jumper J1 on Logic Board and Jumpers J2 and J3 on Power Board (All Models) .....	9
5. Jumper J1 Setting vs Motor Horsepower .....	9
6. Terminal Block Wiring Information .....	10
7. Armature Fuse Chart .....	11
8. Jumper "JW" Operation .....	13
9. Parts Lists .....	22, 23, 26, 27
 <b><u>FIGURES</u></b> 	
1A. Control Layout (Logic Module) .....	4
1B. Control Layout (Main Board) .....	5
2. Typical Indexing Performance .....	6
3. Mechanical Specifications .....	8
4. AC Line and Motor Connection Diagram .....	10
5. Remote Potentiometer Connection .....	11
6. Analog Voltage Connection .....	11
7. Run Command .....	12
8. Jog Command .....	12
9. Jog Command Used as Stop .....	12
10. Stop Command .....	13
11. Jumper "JR" Operation .....	14
12. Solid State Switching .....	14
13. Contact Switching .....	14
14. Correct Keyway Positions for Cam and Limit Switch Assemblies .....	15
15. Cycle on Demand Wiring .....	16
16. Sequence of Cycle on Demand Operation .....	16
17. Reversing Logic Wiring Diagrams .....	17
18. Schematics .....	21, 24, 25
19. Internal Wiring Diagram .....	28

i.  **SIMPLIFIED SETUP AND OPERATING PROCEDURES**

Before operating this control you must read these instructions. They are to be used as a reference only and are not intended to replace the detailed instructions provided herein. **You must read the Safety Warning before proceeding.**





1. **AC Power** – Be sure jumpers J2A and J2B on power board and jumper "J1" on logic board are set to the correct positions to match the AC line input voltage. (See table 4, p. 9.) Connect AC power to terminal block TB1 terminals L1 and L2. When power is turned on, LED 1 on main power board will light. **Be sure AC power is disconnected when making other connections to control. Do not bundle AC power and motor wires with wires connected to TB3 terminals.**

2. **Motor Leads** – Connect the motor leads to terminal block TB2 terminals A1 and A2. Be sure motor nameplate voltage rating corresponds to control output voltage rating. Do not use control with shunt wound motors.



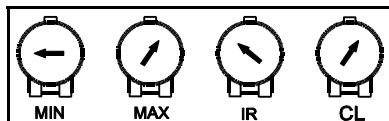
3. **Motor Current Setting** – Be sure Jumper J1 is set to the approximate rated motor current (10A, 5A, 3.3A, 2A).

**JUMPER J1 SETTING vs MOTOR HORSEPOWER**

Jumper J1*	Motor Horsepower Range	
	90 VDC	180 VDC
10A 	3/4 – 1	1 – 2
5A 	Ω	1
3.3A 	1/4 – 1/3	1/2 – 3/4
2A 	1/6	1/3

\*Note: Jumper J1 is shown in the factory setting.

4. **Trimpot Settings** – Trimpots should be set to the approximate position as shown:



5. **Main Speed Pot** – Turn the main speed pot on the front cover of the control to a 15% or greater setting.



## ii. SAFETY WARNING! — PLEASE READ CAREFULLY

This product should be installed and serviced by a qualified technician, electrician or electrical maintenance person familiar with its operation and the hazards involved. Proper installation, which includes wiring, mounting in proper enclosure, fusing or other overcurrent protection and grounding, can reduce the chance of electric shocks, fires or explosion in this product or products used with this product, such as electric motors, switches, coils, solenoids and/or relays. Eye protection must be worn and insulated adjustment tools must be used when working with control under power. This product is constructed of materials (plastics, metals, carbon, silicon, etc.) which may be a potential hazard. Proper shielding, grounding and filtering of this product can reduce the emission of radio frequency interference (RFI) which may adversely affect sensitive electronic equipment. If information is required on this product, contact our factory. It is the responsibility of the equipment manufacturer and individual installer to supply this safety warning to the ultimate user of this product. (SW effective 11/92)

This control contains Start/Stop and Inhibit circuits that can be used to start and stop the control. However, these circuits are never to be used as safety disconnects since they are not fail-safe. Use only the AC line for this purpose.

The potentiometer circuit (P1, P2, P3) of this control is not isolated from AC line. **Be sure to follow all instructions carefully. Fire and/or electrocution can result due to improper use of this product.**

**CE** This product complies with all CE directives pertinent at the time of manufacture. Contact factory for detailed installation instructions and Declaration of Conformity. Installation of a CE approved RFI filter (KBRF-200A, KB P/N 9945C or equivalent) is required. Additional shielded motor cable and/or AC line cables may be required along with a signal isolator (KBSI-240D, KB P/N 9431 or equivalent).

### Special Instruction for Cycle on Demand Applications

The camshaft of the Index drive should be in the middle of its dwell position. This is the position in which the motor should receive its signal to start. Connect the normally closed side of the cycling limit switch (LS1) to the control's TB3 terminals STOP (4) and RTN (3). **Note: See fig. 14, p. 15 for information regarding the correct dwell position and cycling cam lobe positions.**

#### I. GENERAL INFORMATION.

The KBPI INDEXER controls are packaged in a NEMA 4X enclosure which is ruggedly constructed of die cast aluminum. The controls are designed specifically for cycling and indexing applications. A variety of models provide different features and input voltage ratings (see table 1, p. 3). The controls provide the user with **isolated** logic functions: STOP, JOG and RUN. Other functions, such as **cycle on demand**, can easily be obtained. An important feature of the control is jumper J1 which is used for DC current selection. It automatically presets the IR Compensation and Current Limit for safe operation on various motors. Standard features include built-in armature fusing and an LED indicator array for "power on," "stop" and "overload." Part Number 8501 also contain logic input for "Reverse Run" and "Reverse Jog." The controls contain trimpots that can be used to readjust Minimum and Maximum speed, Current Limit and IR Compensation. The front panel contains a built-in 5K ohm speed potentiometer and a Run, Jog/Stop switch. (See table 3, p. 7 for selectable jumper information.)

**IMPORTANT!** Control part number and ratings must correspond to the AC Line voltage, motor voltage and type of operation (Unidirectional or Reversing). See table 1.

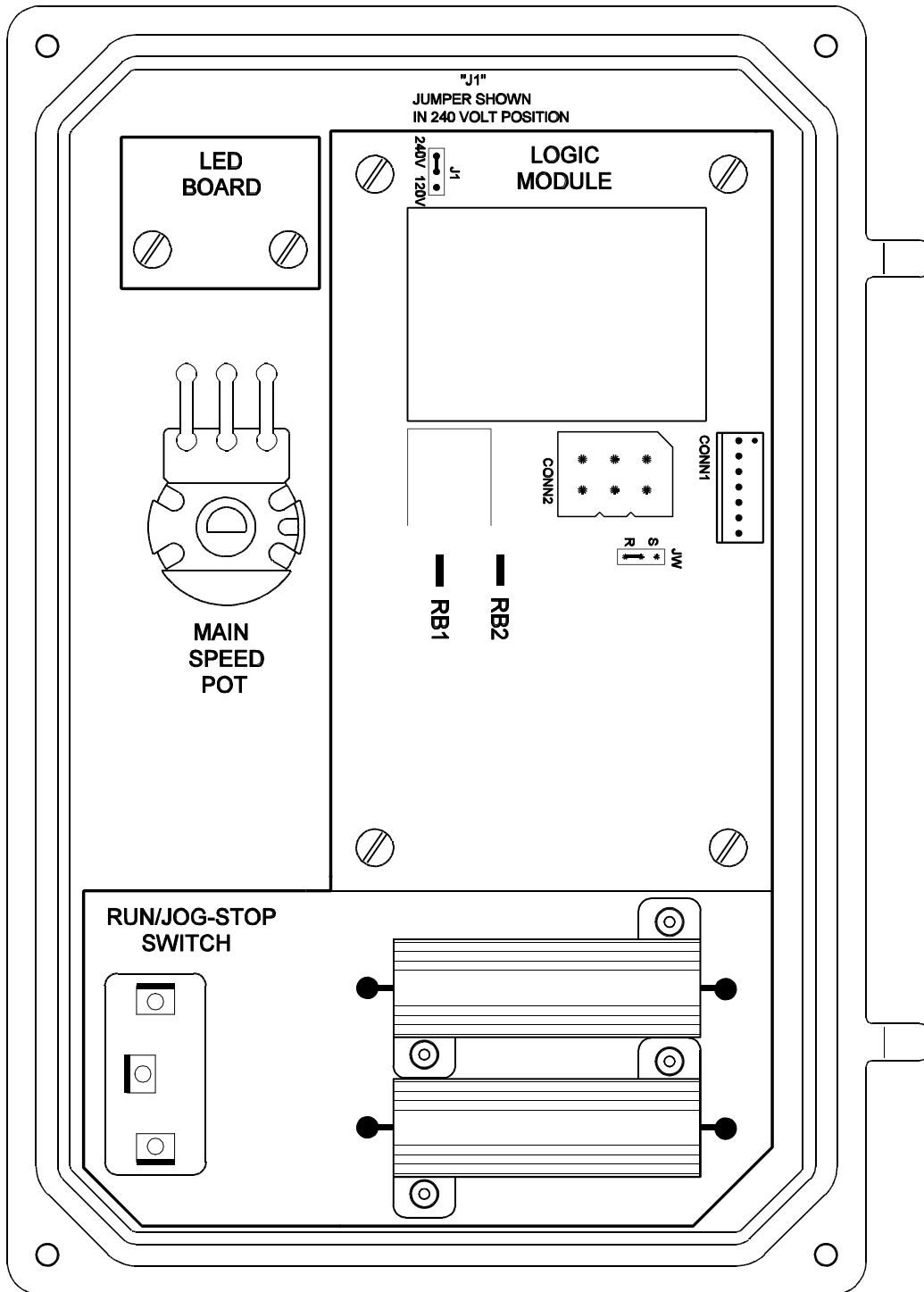
**TABLE 1 – ELECTRICAL RATINGS**

Model Number	Part Number	Input Line Voltage (VAC 50/60 Hz ±10%)	Motor Armature Voltage (VDC)	Maximum AC Load Current (RMS Amps)	Maximum DC Load Current (DC Amps)	Maximum Horsepower HP, (KW)	Type of Operation	Logic Provided
KBPI-240D	8500	120	0 – 90	15.0	10.2	1, (.75)	Unidirectional	Run, Jog, Stop, Rtn
		240	0 – 180	15.0	10.2	2, (1.5)	Unidirectional	Run, Jog, Stop, Rtn
		240	0 – 90*	15.0	10.2	1, (.75)	Unidirectional	Run, Jog, Stop, Rtn
KBPI-240DR	8501	120	0 – 90	15.0	10.2	1, (.75)	Reversing	Fwd Run, Fwd Jog, Stop, Rev Run, Rev Jog, Rtn
		240	0 – 180	15.0	10.2	2, (1.5)	Reversing	Fwd Run, Fwd Jog, Stop, Rev Run, Rev Jog, Rtn
		240	0 – 90*	15.0	10/2	1, (.75)	Reversing	Fwd Run, Fwd Jog, Stop, Rev Run, Rev Jog, Rtn

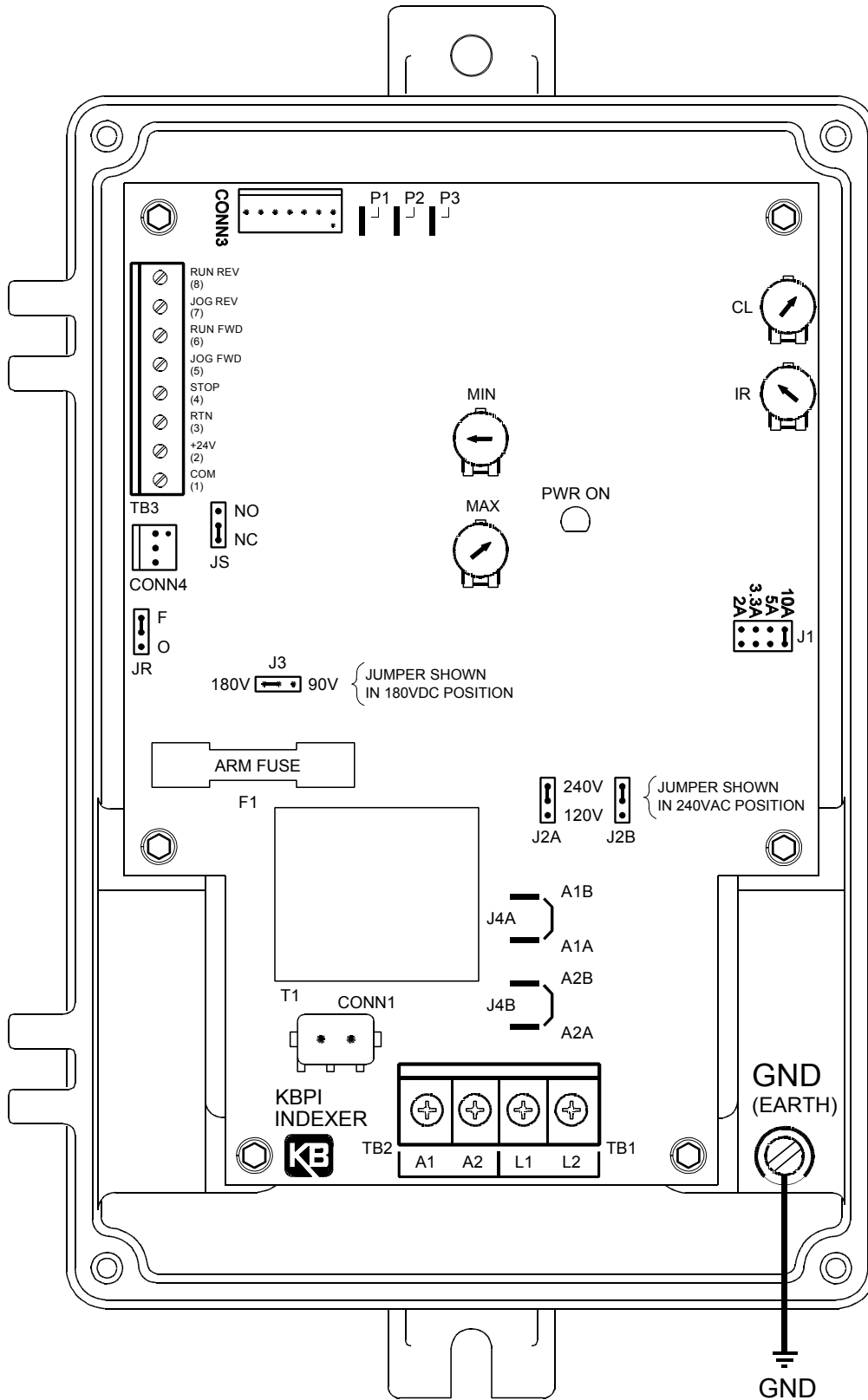
\*Denotes step-down operation. A 90 Vdc motor used on a 240 VAC line input.

**NOTE: Motor performance and brush life may be affected.**

**FIG. 1A CONTROL LAYOUT (Logic Module)**



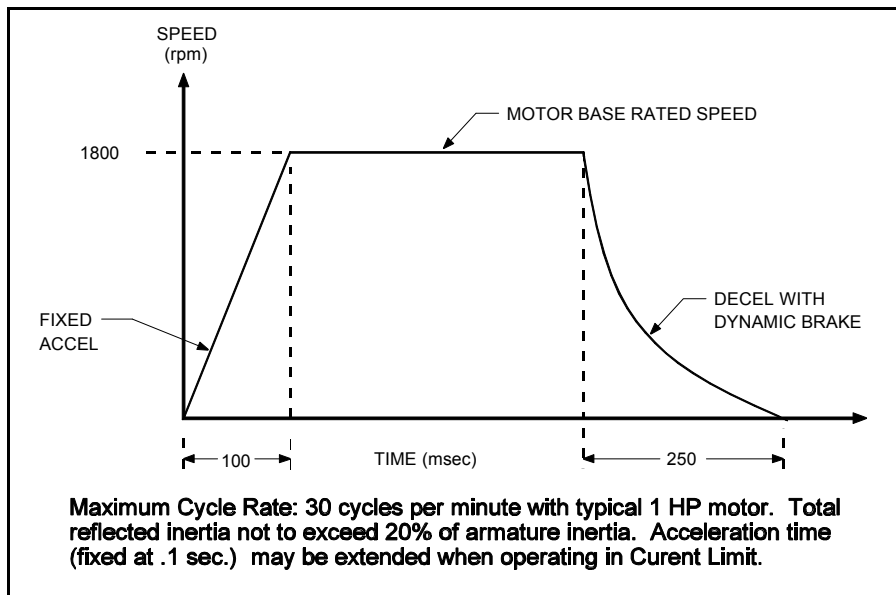
**FIG. 1B CONTROL LAYOUT (Main Board)**



**TABLE 2 – GENERAL PERFORMANCE SPECIFICATIONS**

Parameter (Units)	Specifications		
	Model No. KBPI-240D (P/N 8500) & Model No. KBPI-240DR (P/N 8501)		Factory Setting
AC Line Input (VAC ± 10%, 50/60 Hz)	120	240	240
Horsepower Range (HP) [KW]	1/6 - 1, [.12 - .75]	1/3 - 2, [.25 - 1.5]	2, [1.5]
Armature Voltage Range (VDC)	0 – 100	0 – 200	170
Current Ranges (ADC)	2, 3.3, 5, 10		10
CL Trimpot Range (% Range Setting)	0 – 170		150
Min. Speed Trimpot Range (% base spd)	0 – 30		0
Max. Speed Trimpot Range (% base spd)	60 – 120		100
IR Comp Trimpot Range (VDC)	0 – 30		4
Speed Range (Ratio)	50:1		—
AC Line Voltage Regulation (% base spd)	± 0.5		—
Voltage Following Linearity (% base spd)	± 0.5		—
Load Regulation (% base speed)	± 1		—
Ambient Temp Range (°C)	0 – 45		—
Potentiometer, Front Cover (ohms – watts)	5K – 1/3		—
Maximum Run/Stop Operations (ops/min)	30		—
Enclosure Type (NEMA)	4X		—

**FIG. 2 – TYPICAL INDEXING PERFORMANCE**





**TABLE 3 – SELECTABLE JUMPER REFERENCE CHART**

<b>Jumper</b>	<b>Location*</b>	<b>Description</b>	<b>Factory Setting</b>
J1	1	Establishes the range of maximum armature current.	See sec. IV, p. 9.
J2A, J2B	1	Sets the AC input line voltage (120/240 VAC) for the main PC Board.	Set according to model part numbers. See table 1, p. 3.
J3	1	Sets the DC output voltage range to motor (90V/180V).	Set according to model part numbers. See table 1, p. 3.
JR	1	Used to activate the return (RTN) circuit. "F" position – RTN is jumpered to common. "O" position – RTN used as logic disable. See sec. VII, D, p. 13.	Set to "F" position.
JS	1	Used to set the STOP function operation. "NC" position – Use a normally closed contact for open to stop operation. "NO" position – Use a normally open contact for "close to stop" operation.	Set to "NC" position.
J1	2	Sets the operating AC line voltage for the logic module. (120/240 VAC.)	Set according to model part numbers. See table 1, p. 3.
JW	2	Determines the priority of the Run and Stop logic commands. See table 8, p. 13.	Set to "R" position for "cycle on demand".

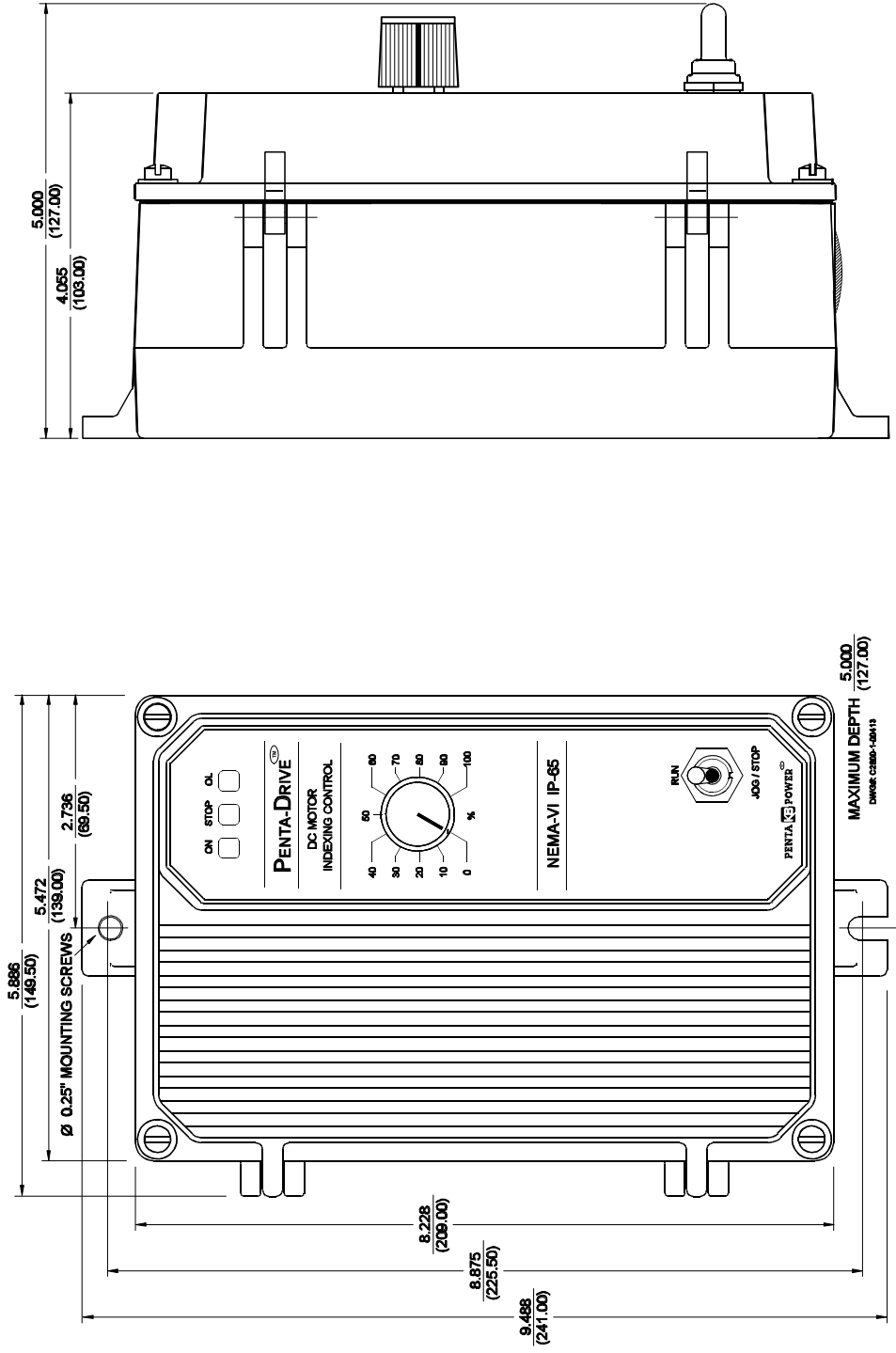
\*Notes: 1) Main Printed Circuit Board. (fig. 1B, p. 5)  
2) Logic PC board. (fig. 1A, p. 4)

**II. MOUNTING.**

Mount the control in a vertical position on a flat surface. Be sure to leave enough room below the bottom of the control to allow for the AC line and motor connections and other wiring that may be necessary. Care should be taken to avoid extreme hazardous locations where physical damage can occur. **Note: Do not use this control in an explosion proof application.** If the control is mounted in a closed, unventilated cabinet, remember to allow for proper heat dissipation. If full rating is required, a minimum enclosure size of 12" W x 24" H x 12" D should be used.

**Front Cover** – The KBPI case is designed with a hinge so that when the front cover is open, all wiring stays intact. To open the cover, the four cover screws must be loosened, so they no longer are engaged in the case bottom. Note that these screws are captive and the front cover holes are threaded. After mounting and wiring, close the front cover, **making sure all wires are contained within the enclosure and the gasket is in place around the cover lip.** Tighten all four cover screws so that the gasket is slightly compressed. **Do not overtighten.**

FIG. 3 – MECHANICAL SPECIFICATIONS INCHES  
[mm]



### III. SETTING AC LINE AND MOTOR VOLTAGE.

The KBPI is factory set to operate with a 230VAC - 50/60 Hz AC line input and a 180-VDC PM motor. By utilizing jumpers J2A, J2B and J3 on the main PC board and Jumper J1 on the logic PC board, different AC line voltage/motor voltage combinations can be achieved.

#### A. FACTORY SETTING: 240 VOLTS AC LINE INPUT WITH 0-180 VDC OUTPUT:

Jumpers J2A, J2B on main PC board set to "240"  
 Jumper J3 on main PC board set to "240"  
 Jumper J1 on logic PC board set to "240"

#### B. 120 VOLTS AC LINE INPUT WITH 0-90 VDC OUTPUT:


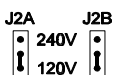


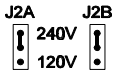


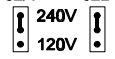

Jumpers J2A, J2B on main PC board set to "120"  
 Jumper J3 on main PC board set to "120"  
 Jumper J1 on logic PC board set to "120"

#### C. 240 VOLTS AC LINE INPUT WITH 0-180 VDC OUTPUT (STEP-DOWN):

Jumpers J2A, J2B on main PC board set to "240"  
 Jumper J3 on main PC board set to "120"  
 Jumper J1 on logic PC board set to "240"

The above information is summarized in table 4.

**TABLE 4 – Relationship of AC Line Input and Motor Voltage with Jumper J1 on Logic Board and Jumpers J2 and J3 on Power Board (All Models)**

AC Line Voltage (VAC -50/60Hz)	J1 Position Logic Board		J2A, J2B Position Power Board		Motor Voltage (VDC)	J3 Position on Power Board
	Setting	Diagram	Setting	Diagram		
120	120V		120V, 120V		90V	
240	240V		240V, 240V		180V	
240	240V		240V, 240V		90V*	





\*Denotes step-down operation. A 90 VDC motor used on a 240 VAC line input.

**Note: Motor performance and brush life may be affected.**

### IV. SETTING MOTOR CURRENT (JUMPER J1)

Jumper J1 is used to set the range of armature current which can be further modified with the current limit (CL) trimpot. The factory setting of J1 is 10 amps. The CL trimpot is factory set to provide 150% of the J1 setting. For example, when J1 is in the 10 amp position, the actual armature current is 15 amps. When J1 is in the 5 amp position, the control provides a maximum armature current of 7.5 amps. The position of J1 should be set to the approximate DC motor current rating. Table 5 is provided as a reference. (See fig. 1b, p. 5 for location of jumper J1.)

**TABLE 5 – JUMPER J1 SETTING vs MOTOR HORSEPOWER**

Jumper J1*	Motor Horsepower Range	
	90 VDC	180 VDC
10A 	3/4 – 1	1 – 2
5A 	Ω	1
3.3A 	1/4 – 1/3	1/2 – 3/4
2A 	1/6	1/3

\*Note: Jumper J1 is shown in the factory setting.

## V. WIRING



**WARNING!** Read Safety Warning on page 2 before attempting to use this control. Wire control in accordance with the National Electric Code requirements and other codes that apply. Be sure to fuse each conductor which is not at ground potential. Failure to follow the Safety Warning Instructions may result in electric shock, fire or explosion. **Do not fuse neutral or grounded conductors.** Note: See sec. VI, p.11 Fusing. A separate AC line switch, or contactor, must be wired as a disconnect switch, so that the contacts open each ungrounded conductor. (See fig. 4 for AC Line and Armature connection.) **Note: Do not bundle AC or motor leads with logic leads or erratic operation may occur.**

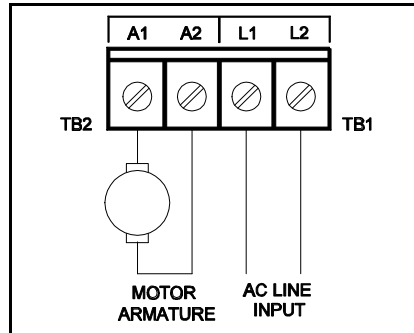
1. Twist logic wires (speed adjustment potentiometer or voltage signal input wires) to avoid picking up electrical noise. If wires are longer than 18," use shielded cable.
2. You may have to earth ground the shielded cable. If noise is coming from devices other than the drive, ground the shield at the drive end (ground screw in enclosure). If noise is generated by a device on the drive, ground the shield at the end away from the drive. Do not ground both ends of the shield.
3. Do not bundle logic wires with power carrying wires or other sources of electrical noise. Never run speed adjustment potentiometer or voltage signal input wires in the same conduit as motor or AC line voltage wires.
4. Connect earth ground to the earth ground screw provided in the enclosure. (See fig. 1B, p. 5 for ground screw location.)

Two .875" (22.2 mm) knockout holes are provided for a standard 1/2" knockout connector (not supplied) for wiring. A plug is provided if only one knockout is required. Be sure to use suitable connectors and wiring that are appropriate for the application.

- A. **AC Line** – Connect AC Line to terminals L1 and L2. (Be sure jumper J1 on the Logic Board and jumpers J2A and J2B on the Power Board are set to the correct position to match the AC Line input voltage. (See table 4 p. 9.)
- B. **Motor Armature** – Connect motor armature to terminals A1 (+) and A2 (-). (Be sure jumper J3 on the Power Board is set to the correct position 90V, 180V to match the motor voltage. (See table 4, p. 9.)

**WARNING!** Do not wire switches or relays in series with the armature. **Armature switching can cause catastrophic failure of motor and/or control. Do not bundle AC line and motor wires with other wires (e.g.: potentiometer, analog input, Run, Jog, Stop, etc.) since erratic operation may occur. Do not use this control on shunt wound motors.**

**FIG. 4 – AC LINE AND MOTOR CONNECTION DIAGRAM**



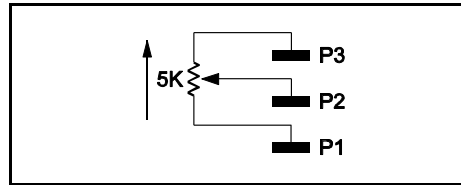
**TABLE 6 – TERMINAL BLOCK WIRING INFORMATION**

Terminal Block Designation	Connection Designation	Supply Wire Gauge*		Maximum Tightening Torque ( in – lbs)
		MINIMUM	MAXIMUM	
TB1	L1, L2	22	12	12
TB2	A1, A2	22	12	12
TB3	Logic Connections	24	14	3.5

\*Use Cu wire only (AWG)

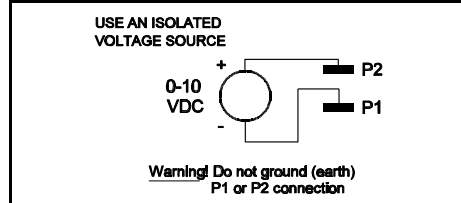
C. **Ground** – Be sure to ground (earth) the control by connecting a ground wire to the Green Ground Screw located to the right of the terminal block. **Do not connect ground wire to any other terminals on control.**

**FIG. 5 – REMOTE POTENTIOMETER CONNECTION**



D. **Main Potentiometer** – The control is supplied with the main potentiometer prewired. However, the control can also be operated from a remote potentiometer, or from an *isolated* analog voltage for voltage following. To operate from an external source remove **white, orange and violet** potentiometer leads from terminals P1, P2 and P3. The leads may be taped and left in the control. The potentiometer itself may be removed, if a seal is used to cover the hole in the front cover. **Note: Use shielded cable on all connections to P1, P2, or P3 over 12" (30cm) in length. Do not ground shield.**

**FIG. 6 – ANALOG VOLTAGE CONNECTION**



1. Remote Potentiometer. Connect remote potentiometer wires to terminals P1, P2 and P3, so that the "high" side of the potentiometer connects to P3, the "wiper" to P2 and the "low" side to P1. (See fig. 5.)
2. Analog Input. An *isolated* 0-10VDC analog voltage can also be used to drive the control. **Note: If an isolated signal voltage is not available, an optional signal isolator (KB P/N 9431) should be used.** Connect the *isolated* input voltage to terminal P2 (positive) and P1 (negative). (See fig. 6.) Adjust the MIN trimpot clockwise to achieve a 0<sup>+</sup> output voltage.

**VI. FUSING.**

- A. **AC Line Fusing** – Most electrical codes require that each ungrounded conductor contain fusing. Separate branch circuit fusing or circuit breaker may be required. Check **all** electrical codes that may apply to the installation. This control does **not** contain AC line fuses. A 20 amp rated fuse or circuit breaker can be used.
- B. **Armature Fusing** – The control contains a built in armature fuse holder. An armature fuse rated 1.5 times higher than the full load of the motor, must be installed before operating the control. This fuse should not blow unless the motor is shorted or another catastrophic failure occurs. An armature fuse replacement such as Littelfuse 326 or Buss ABC ceramic fuse or equivalent can be used. Fuse supplied separately from your distributor. See table 7 for armature fuse chart.

**TABLE 7 – ARMATURE FUSE CHART**

Motor Horsepower		Approx. DC Motor Current Amps	Fuse Rating (AC Amps)
90VDC	180VDC		
1/6	1/3	1.7	2
1/4	1/2	2.5	4
1/3	3/4	3.3	5
1/2	1	5.0	8
3/4	1	7.5	12
1	2	10.0	20

**Note: Armature fuse is not supplied and must be installed for control to operate.**

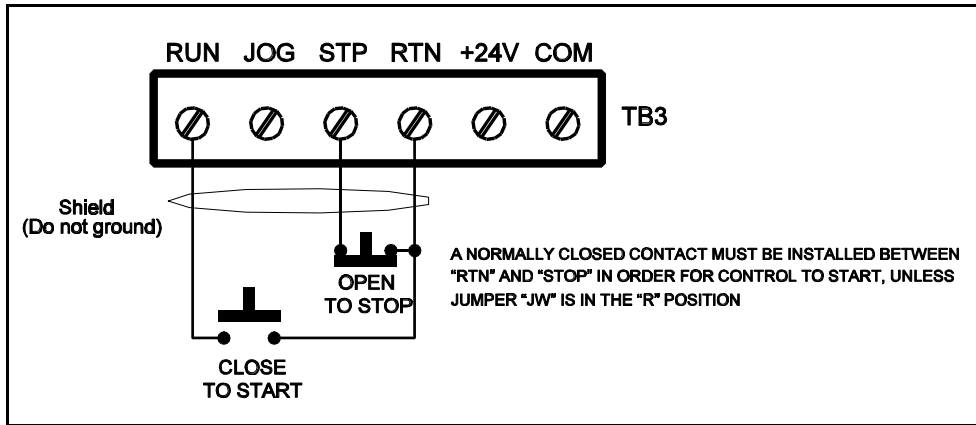
VII. LOGIC FUNCTIONS AND WIRING.

**Warning!** Do not use any of the logic functions (STP, RTN) as an emergency stop since they are not fail safe. Use only an AC line (L1, L2) disconnect for that purpose. To prevent erratic operation, do not bundle logic wiring with AC line and motor wires. Use shielded cables on logic wiring over 12" (30 cm) in length. Do not ground or common shield.

The control contains several logic functions which are described in detail below. All connections are made to terminal block TB3. (See fig. 1B, p. 5 for TB3 location.)

- A. **"RUN"** – A *momentary* contact closure between terminals "RUN" and "RTN" latches the control into a continuous run mode. To stop the control, the stop circuit must be activated by opening the contact between the "STP" and "RTN" terminals. **Note: All momentary closures must be present for no less than 50 milliseconds and a normally closed (NC) contact must be maintained between the "STP" and "RTN" terminals in order for the drive to run.**

FIG. 7 – RUN COMMAND



- B. **"JOG" (Stop)** – A maintained contact closure between terminals "JOG" and "RTN" will cause the control to run continuously. This is not a latching function. The drive will **run** only as long as the contact is closed and **stop** when it is opened. (See fig. 8.)

FIG. 8 – JOG COMMAND

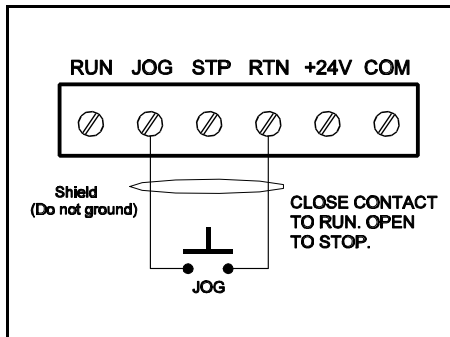
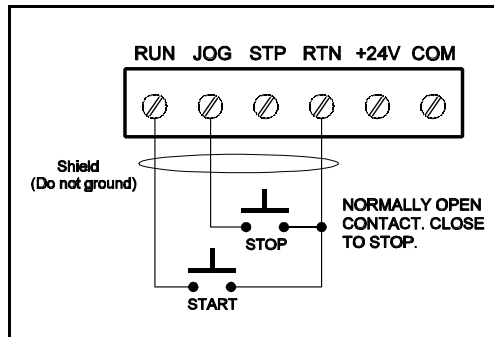


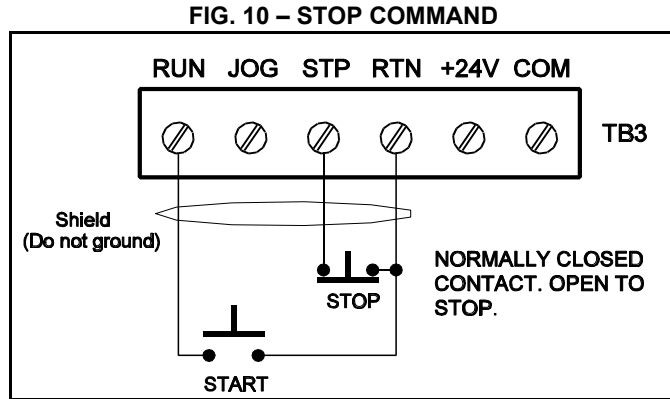
FIG. 9 – JOG COMMAND USED AS STOP



**Application Note:**

The "JOG" can also be used as a normally open (NO) STOP command. When the control is started with the momentary "RUN" command, it can be stopped by connecting a momentary contact between the "JOG" and the "RTN" terminals. See fig. 9. (Note: The control can also be stopped by opening the "STP" contact.)

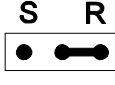
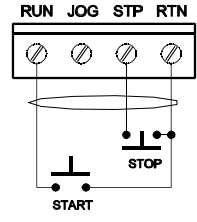
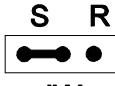
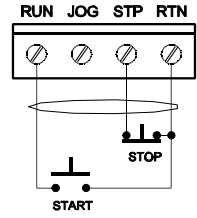
C. **"STOP" (STP)** — Use a normally closed (NC) contact between terminals "STP" and "RTN." Opening the contact activates the control's Dynamic Brake producing a rapid stop. (Note: A normally open (NO) limit switch or contact can also be used to activate the stop command. To use a (NO) contact move jumper JS to the "NO" position). (See table 3, p. 7.)



**Application Note:**

The setting of jumper "JW" establishes the priority a "STOP" command has over a "RUN" command. If jumper "JW" is placed in position "S," the "STOP" command has priority over the "RUN". If the "STOP" is activated (contact open), the control cannot be started with the "START" command. If jumper "JW" is in the "R" position (factory setting), the "RUN" command has priority over the "STOP." In this mode of operation the control can be started with the "RUN" command even though the "STOP" is activated (contact open). This setting of jumper JW in the "R" position is used for cycle on demand applications. See table 8 for detailed information of jumper "JW" operation. **Warning!** Do not use as safety stop. See Safety Warning on page 2.

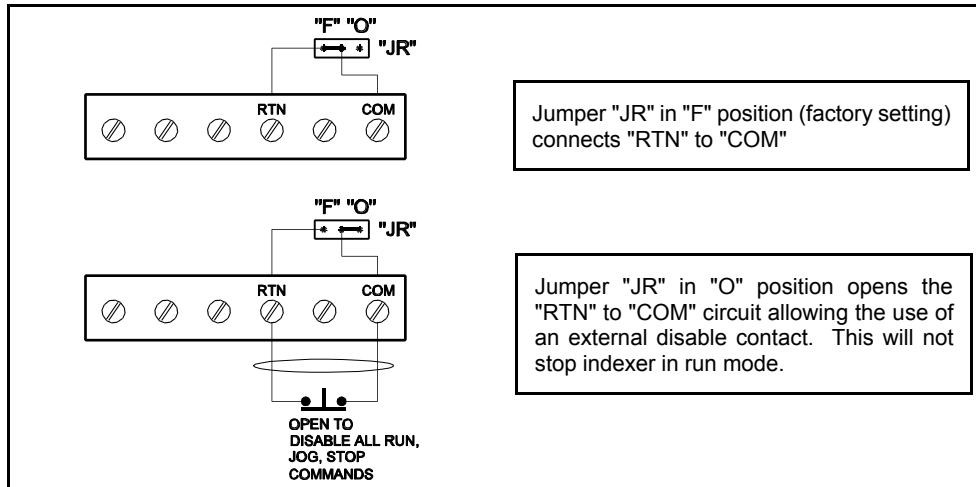
**TABLE 8 – JUMPER "JW" OPERATION**

JUMPER "JW" SETTING	DESCRIPTION	CIRCUIT	OPERATION
 <p style="text-align: center;"><b>JW</b></p> <p style="text-align: center;">"R" (Factory Setting)</p>	<p>"Run" has priority over "Stop." Control will run even if stop contact is open. *(Use this setting for "Cycle on Demand" operation.)</p>		<p>When start contact is made, control will run with "STP" open. If "STP" is closed and then reopened, control will stop.</p>
 <p style="text-align: center;"><b>JW</b></p> <p style="text-align: center;">"S"</p>	<p>"Stop" has priority over "Run." Control will run only when "STP" contact is closed.</p>		<p>When start contact is made, "STP" contact must be closed for control to run.</p>

D. **"RETURN" (RTN)** – When Jumper "JR" is moved to position "O" from the factory setting "F" it disables all of the command functions (Run, Jog, Stop, etc.). To enable these functions a contact must be placed between the "RTN" and "COM" terminals. Note: Opening the return control will not stop the indexer, if opened while indexer is running.

**Warning! Do not use as emergency or safety stop. See Safety Warning on page 2. See fig. 11, p. 14, for jumper "JR" operation. Failure to follow the Safety Warning Instructions may result in electric shock, fire or explosion.**

**FIG. 11 – JUMPER “JR” OPERATION**



- E. **+24 VDC SUPPLY** – The +24V terminal provides a nominal<sup>1</sup> 24 VDC @ 12 mA output for use with an external load such as one solid-state 3-wire proximity switch.
- F. **Common "COM"** — This terminal is referenced to all logic signals (RUN, JOG, STOP) through the Return ("RTN") terminal. The control is factory supplied with jumper "JR" in the "F" position which connects the "RTN" and "COM" terminals together.

**Note: Control will not operate unless jumper "JR" is in the "F" position.**

**VIII. APPLICATION WIRING DIAGRAMS.**

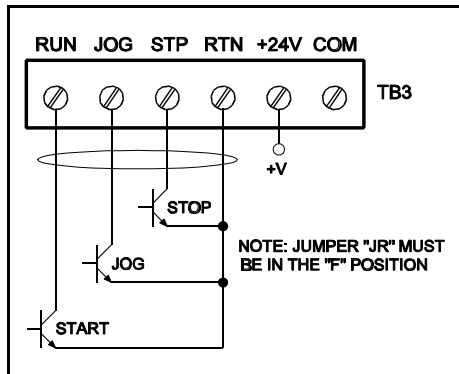
**Example 1:**

Solid-state switching devices, such as NPN transistors or proximity switches, may be used for logic commands if they meet the following criteria:

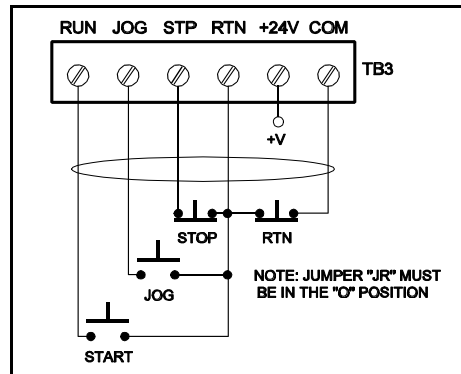
Must be capable of switching 30 VDC, at 24 mA, with an off-state leakage current of less than 1 mA. (See fig. 12.) **Warning!** Do not ground or short +24V to com or return on TB3. Do not use +24V for other than open collector sensors. (See fig. 12.)

**Example 2:** For optimum operation, contacts used on logic inputs should be rated for low-level logic switching (i.e. gold contacts). (See fig 13.)

**FIG. 12 – SOLID STATE SWITCHING**



**FIG. 13 – CONTACT SWITCHING**



<sup>1</sup>Output voltage provided can vary between 20 and 24VDC



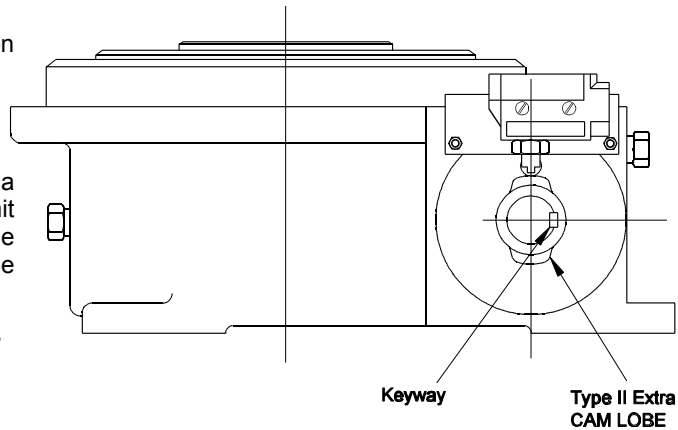
**Example 3: “Cycle on Demand” – Important Information**

In a “Cycle on Demand” application, the Indexer Drive will make one complete cycle of movement of table or conveyor and then dwell until it receives an external signal from the machine’s controller or operator to start again. If motor receives a signal to start while the Indexer Drive is in its dwell position, the motor will accelerate from a paused position to full speed during one half of the dwell of the main indexer cam. When the motor has reached its maximum speed and is no longer accelerating, the motion of the Indexer Drive can start. As the Indexer re-enters its dwell portion of the main cam, the signal cam located on the camshaft of the Indexer Drive will actuate the limit switch to signal a stop (**Note: Due to time delays, the signal cam may have to signal a stop some degrees before the indexer drive actually enters the dwell.**) It is important that the motor is made to stop while in the dwell of the main cam. Stopping in any other position could damage the control or the Indexer Drive! (See fig. 14A, 14B and 14C on page 15.)

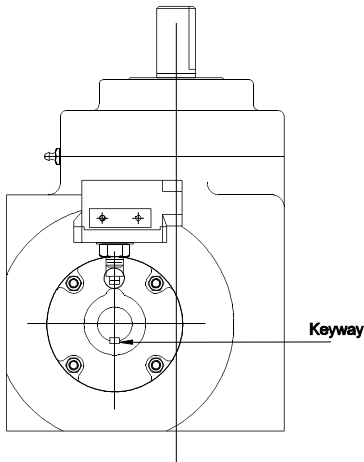
**FIG. 14 – CORRECT KEYWAY POSITION FOR CAM AND LIMIT SWITCH ASSEMBLIES**

A standard Roller Gear unit with the CAM & Limit Switch mounted on the correct keyway position directly opposite of the output shaft, 90° (clockwise) from the CAM Lobe. The CAM & Limit Switch may also be mounted on the reducer. \*If the unit has a “Type II” motion, a special Limit Switch CAM is needed with one extra Lobe, 180° from the first Lobe (as shown).

**FIG. 14A – ROLLER GEAR UNIT**

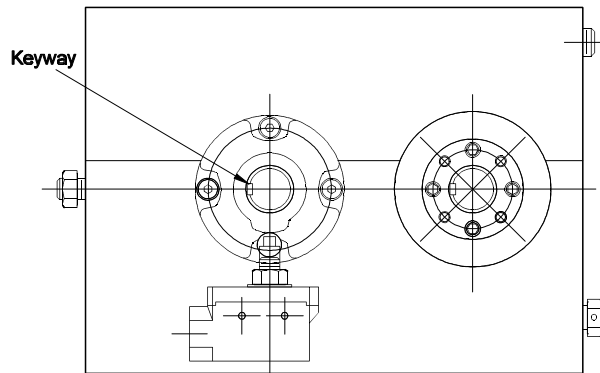


**FIG. 14B – RIGHT ANGLE UNIT**



A standard right angle unit with the CAM & Limit Switch mounted on the housing has a correct keyway position directly opposite of the CAM Lobe. CAM & Limit Switch may also be mounted on the reducer.

**FIG. 14C – PARALLEL UNIT**



A standard parallel unit with the CAM & Limit Switch mounted on the housing has a correct keyway position directly opposite of the output shaft, 90° (clockwise) from the CAM Lobe. CAM & Limit Switch may also be mounted on the reducer.

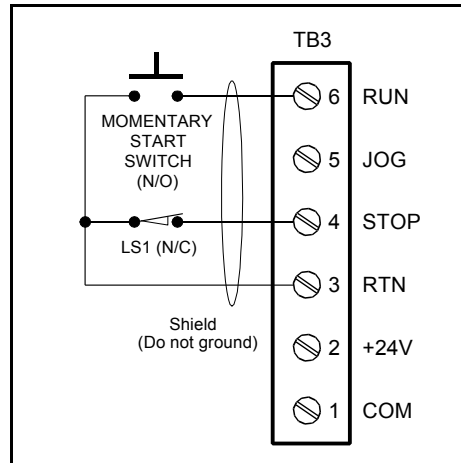
The "Cycle on Demand" function is required for most indexing table applications. The control can be easily set for this operation as follows:

1. Jumper "JW" must be in the "R" position (factory setting) see table 8, p. 13.
2. Jumper "JR" must be in the "F" position (factory setting) see sec. VII, D, p. 13.
3. Wire limit switch LS1 (normally closed) and start switch (normally open) as shown.

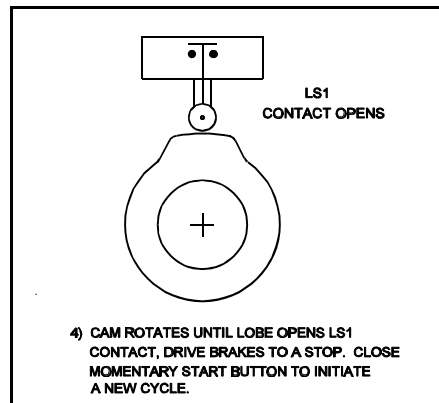
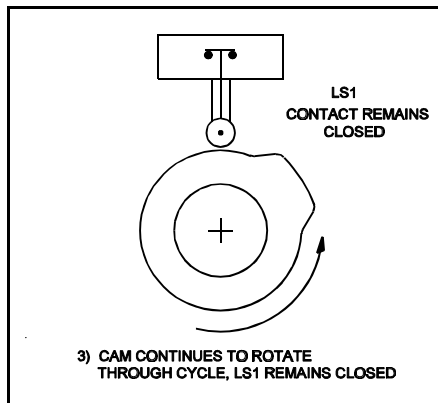
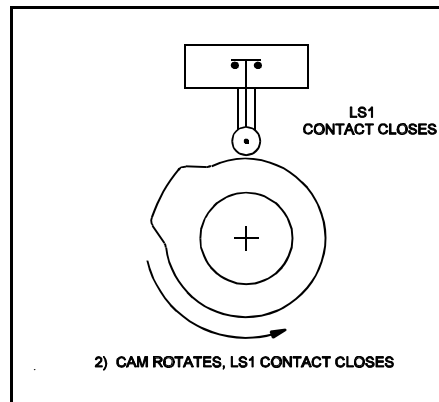
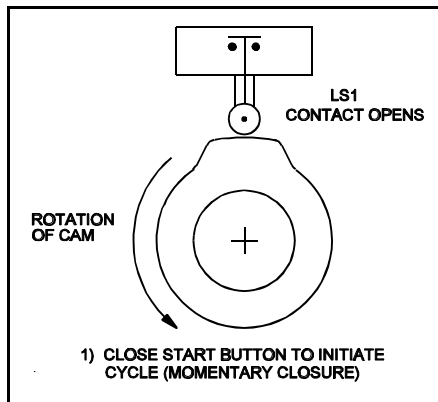
The "Cycle on Demand Operation" begins with limit switch LS1 riding on the cam lobe. (Since LS1 is a normally closed switch, it will be open when riding on the lobe.) The cycle is initiated by momentarily closing the start switch. The drive will start even though LS1 is open (Jumper JW is in the "R" position giving priority to the start switch which overrides the stop.) As the cam shaft rotates it moves off LS1 which closes. When the lobe rotates around back to LS1, LS1 now opens and the drive stops. The drive is now ready to repeat the cycle by initiating another start command. See fig. 16.

**Note: A normally open (NO) STOP contact can also be used. To convert to a normally open STOP, move jumper JS from the factory position "NC" to position "NO."**

**FIG. 15 – CYCLE ON DEMAND WIRING**



**FIG. 16 – SEQUENCE OF CYCLE ON DEMAND OPERATION**



**IX. APPLICATION WIRING DIAGRAMS**

Reversible Model KBPI-240DR (120/240 VAC)

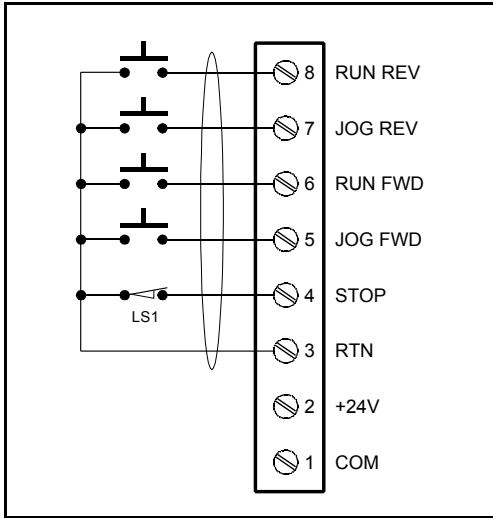
Reversing models carry out the same functions as the unidirectional models except they can be made to index in both the forward and reverse direction. A special circuit APRM<sup>®</sup> provides a lockout feature that prevents catastrophic damage to the drive if a "Reverse" command is given during "Forward" operation (and vice versa). The reversing drives contain two additional positions on the terminal block: "Run Rev" and "Jog Rev." The stop logic command is made with a normally closed (NC) contact.

**Note: The sense of the stop logic can be changed from normally closed (NC) to normally open (NO) by placing jumper JS in the "NO" position.**

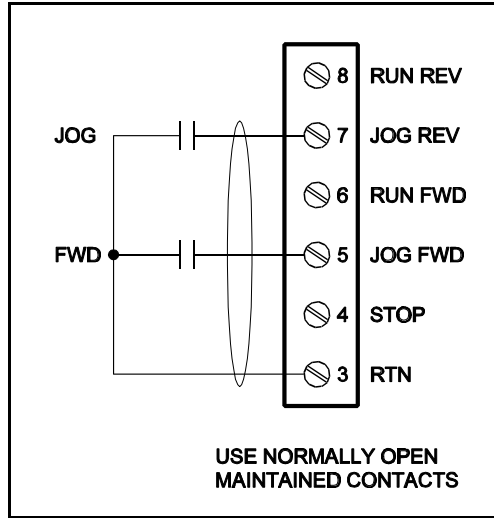
The following wiring diagrams illustrate typical logic circuits. Many other configurations are possible. Consult factory if help is needed.

**FIG. 17 – SEQUENCE OF CYCLE ON DEMAND OPERATION**

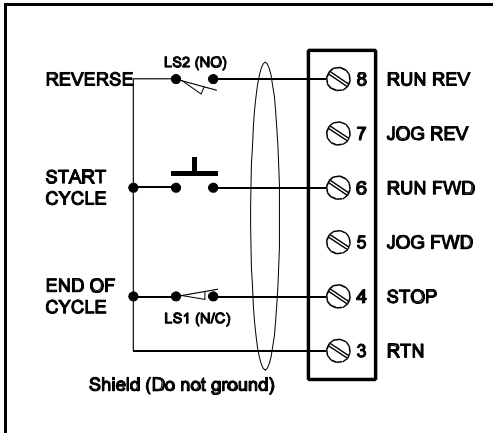
**FIG. 17A – GENERAL CONNECTION DIAGRAM**



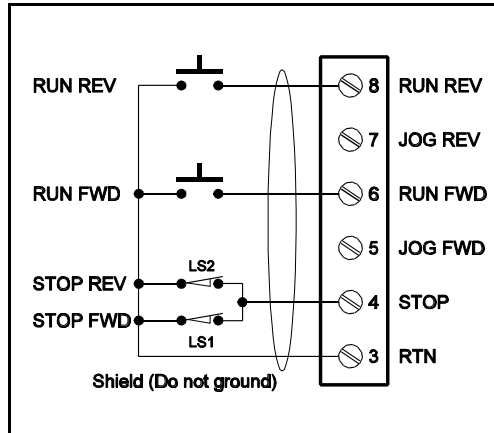
**FIG. 17B – REVERSING USING EXTERNAL CONTACTS**



**FIG. 17C – CYCLE ON DEMAND WITH REVERSE**



**FIG. 17D – FORWARD AND REVERSE CYCLE ON DEMAND**



## X. OPERATION.



**WARNING! Read Safety Warning on page 2 before attempting to operate the control or severe injury or death can result. Failure to follow the Safety Warning Instructions may result in electric shock, fire or explosion.**

After the control has been set up properly (the jumpers set to the desired positions and the wiring completed), the start-up procedure can begin. If AC power has been properly brought to the control, the "ON" and the "STOP" indicators will be lighted. Before starting control, be sure the main potentiometer is set to approximately 15% rotation. To start the control, move the Run - Jog/Stop toggle to the "Run" position and release. The "Stop" indicator should extinguish and the motor should rotate. The motor will increase in speed as the potentiometer knob is rotated clockwise.

**Note: If the motor rotates in the wrong direction, it will be necessary to disconnect the main AC power and reverse the armature wires. To stop the motor, move the Stop toggle to the Stop position. If power is lost the control will not restart, unless the Run-Jog/Stop toggle is moved to the "Run" position.**

## XI. TRIMPOT ADJUSTMENTS.

The control contains trimpots which have been factory adjusted for most applications. Figure 1B on page 5, illustrates the location of the trimpots and their approximate adjustment positions. Some applications may require readjustment of the trimpots in order to tailor the control to exact requirements. (See table 2, p. 6 for range and factory setting of trimpots.) Readjust trimpots as follows:



**WARNING! Do not adjust trimpots with main power on if possible. If adjustments are made with power on, insulated adjustment tools must be used and safety glasses must be worn. High voltage exists in this control. Electrocutation and/or fire can result if caution is not exercised. Safety Warning on page 2 must be read and understood before proceeding. Failure to follow the Safety Warning Instructions may result in electric shock, fire or explosion.**

- A. Minimum Speed (MIN)** – The MIN trimpot is used to set the minimum voltage of the drive. This sets the minimum speed of the motor. Adjust the MIN trimpot as follows:
  1. Rotate Main Potentiometer to minimum speed position (full counterclockwise).
  2. Increase setting of MIN trimpot so that motor runs at desired minimum speed.
- B. Maximum Speed (MAX)** – The MAX trimpot is used to set the maximum voltage of the drive. Adjust the MAX trimpot as follows:
  1. Rotate Main Potentiometer to maximum speed position (full clockwise).
  2. Adjust MAX trimpot setting to desired setting of motor speed.
- C. Current Limit (CL)** – This trimpot is used to set the maximum amount of DC current that the motor can draw. The amount of DC current determines the amount of motor torque. The CL trimpot is factory set at 150% of the current established by the jumper J1 selection. Readjust the CL trimpot as follows:
  1. Turn CL trimpot to minimum (CCW) position. Be sure jumper J1 is in proper position approximately equal to the motor DC ampere rating. (See sec. IV, p. 9.)
  2. Set the main potentiometer at approximately 30 – 50% rotation.
  3. Wire in a DC ammeter in series with armature lead. Lock shaft of motor.
  4. Apply power. Rotate CL trimpot CW until desired CL setting is reached (factory setting is 1.5 times rated motor current).

**CAUTION:**

1. Adjusting the CL above 150% of motor rating can cause overheating and demagnetization of some PM motors. Consult motor manufacturer.
2. Do not leave the motor in a locked condition for more than a few seconds since armature damage may occur.

**D. IR Compensation (IR)** – The IR Comp circuit is used to stabilize motor speed under varying loads. Readjust the IR trimpot as follows:

1. Run the motor at approximately 30-50% of rated speed under no load and measure actual speed.
2. Load the motor to rated current. Rotate IR trimpot so that the loaded speed is the same as the unloaded speed measured in 1.

Control is now compensated so that minimal speed change will occur over a wide range of motor load. **[Note: Too much IR Comp will cause unstable (oscillatory) operation.]**

**XII. FUNCTION INDICATOR LAMPS.**

The control contains three LED Indicator Lamps on the front cover that reflect its operational status.

**A. Power On Indicator (ON)** – This lamp will glow GREEN when the AC line is connected to the control. **(Note: As a convenience, an additional power on indicator (Green) is located on the main printed circuit board.)**

**B. Stop Indicator (STOP)** – This lamp will glow YELLOW when the control is placed in the STOP mode with the Run, Jog/Stop Switch or logic contact.

**C. Overload Indicator (OL)** – When the motor is loaded to the current limit setpoint (CL setpoint is established by the setting of jumper J1 and the CL trimpot) this lamp will glow RED. If the OL indicator remains lit during control operation, a fault condition may exist. Possible causes for this condition are as follows:

1. Motor is overloaded - check motor amps with DC ammeter in series with armature.
2. Motor may be defective - check motor for shorts or grounds.
3. The CL may be set too low - check position of jumper J1 and CL trimpot.

**Note: In some applications, especially those requiring the motor to cycle on and off or from one speed to another, the OL indicator may blink indicating a transient overload. This is a normal condition for the application.**

## **XIII – TROUBLESHOOTING GUIDE**

---

### **MOTOR WILL NOT RUN:**

1. Check control operation by placing RUN - JOG/STOP in RUN position.
  2. Make sure disconnect fuses or circuit breaker in AC line are okay.
  3. Check fuse on PC board and if open, replace.
  4. Check logic. See Start-up Procedures and Application Section.
  5. Be sure speed pot is not set at zero.
  6. Unit is in current limit – See if "OL" indicator is lighted. Check position of jumper J1. (See table 5, p. 9) and CL trimpot setting.
  7. With power removed from unit and motor leads disconnected, check motor for worn or improperly seated brushes.
  8. Check for locked motor shaft.
  9. Contact Factory.
- 

### **FUSE BLOWING:**

1. Improper wiring – check AC line and motor wiring. Be sure ground wire is connected **only** to the Green ground screw.
  2. Improper AC line voltage. Be sure 120VAC is connected to 120VAC rated controls and 240VAC is connected to 240VAC rated controls.
  3. Motor brushes worn or improperly seated.
  4. Motor load is too heavy. Check for machine "jam-up" or excessive load. ("OL" LED is continuously lighted.)
  5. Contact Factory.
- 

### **BRAKING NON-FUNCTIONAL** (control may not stop):

1. Improper logic wiring.
  2. Motor brushes worn or improperly seated.
  3. Contact Factory.
- 

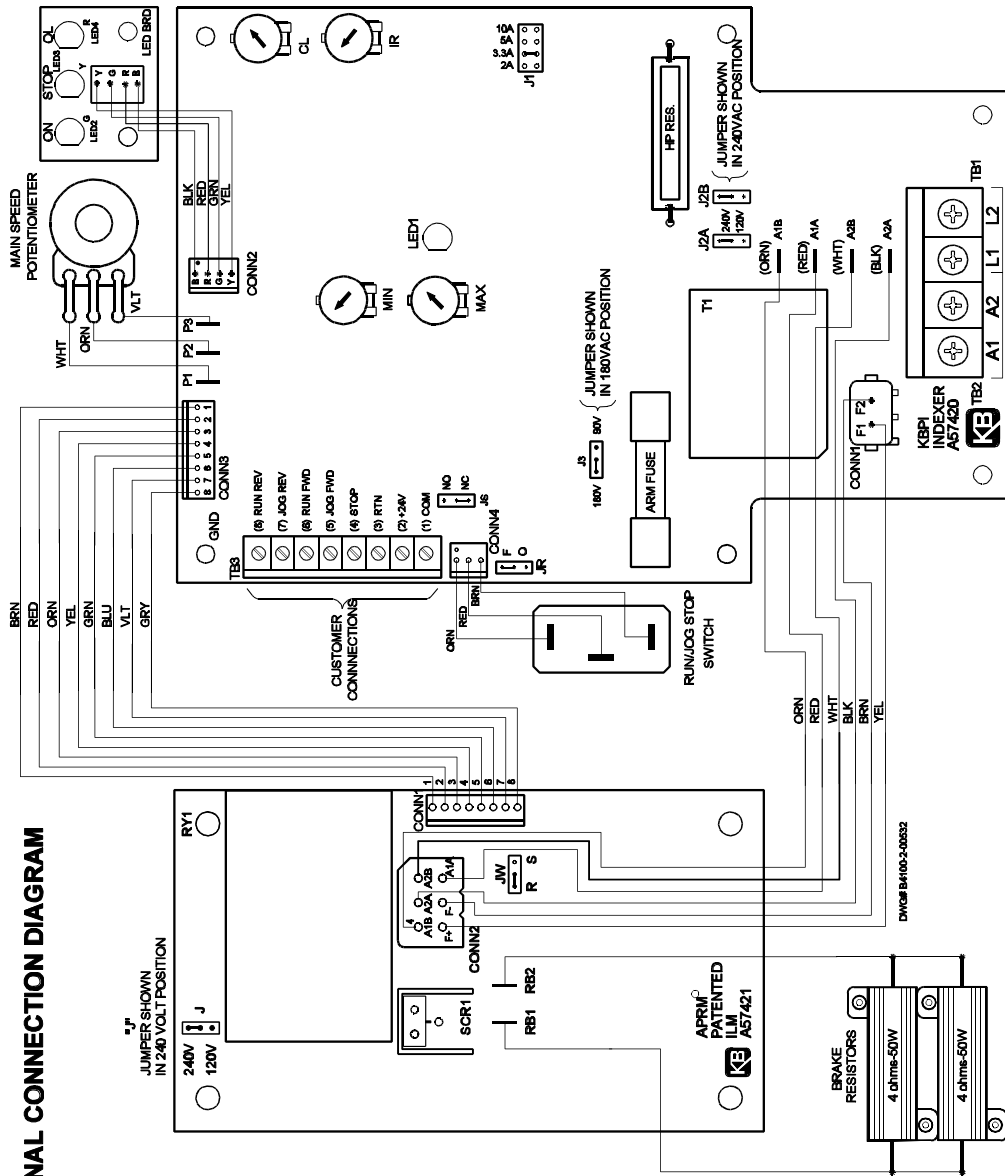
### **NO SPEED CONTROL:**

1. Speed pot miswired or wiring defective.
  2. Control not set up properly (see Application Section).
  3. Contact Factory.
- 

### **MOTOR WILL NOT RUN AT 1725 RPM:**

1. Improper setting of Max Speed trimpot – rotate pot clockwise to increase speed.
2. Unit is in current limit ("OL" LED is lighted). (See sec. XI, C, p. 18.)
3. Low line voltage. Check AC line voltage: 115VAC  $\pm 10\%$  or 230VAC  $\pm 10\%$ .
4. Verify motor nameplate voltage complies with control output voltage rating.
5. Contact Factory.

**FIG.19 – INDEXER INTERNAL CONNECTION DIAGRAM**



#### **XIV – LIMITED WARRANTY**

For a period of 18 months from date of original purchase, KB will repair or replace without charge devices which our examination proves to be defective in material or workmanship. This warranty is valid if the unit has not been tampered with by unauthorized persons, misused, abused, or improperly installed and has been used in accordance with the instructions and/or ratings supplied. The foregoing is in lieu of any other warranty or guarantee, expressed or implied, and we are not responsible for any expense, including installation and removal, inconvenience, or consequential damage, including injury to any person, caused by items of our manufacture or sale. Some states do not allow certain exclusions or limitations found in this warranty so that they may not apply to you. In any event, KB's total liability, under all circumstances, shall not exceed the full purchase price of this unit. (rev 4/88)



**KB ELECTRONICS, INC.**

12095 NW 39th Street, Coral Springs, FL 33065 • (954) 346-4900 • Fax (954) 346-3377  
Outside Florida Call **TOLL FREE** (800) 221-6570 • **E-mail** – [info@kbelectronics.com](mailto:info@kbelectronics.com)  
[www.kbelectronics.com](http://www.kbelectronics.com)

(A40285) – Rev. E – 1/99