

# KBWD

## PULSE WIDTH MODULATED WHISPER DRIVE™

PWM DC MOTOR SPEED CONTROLS  
For PM DC Motors

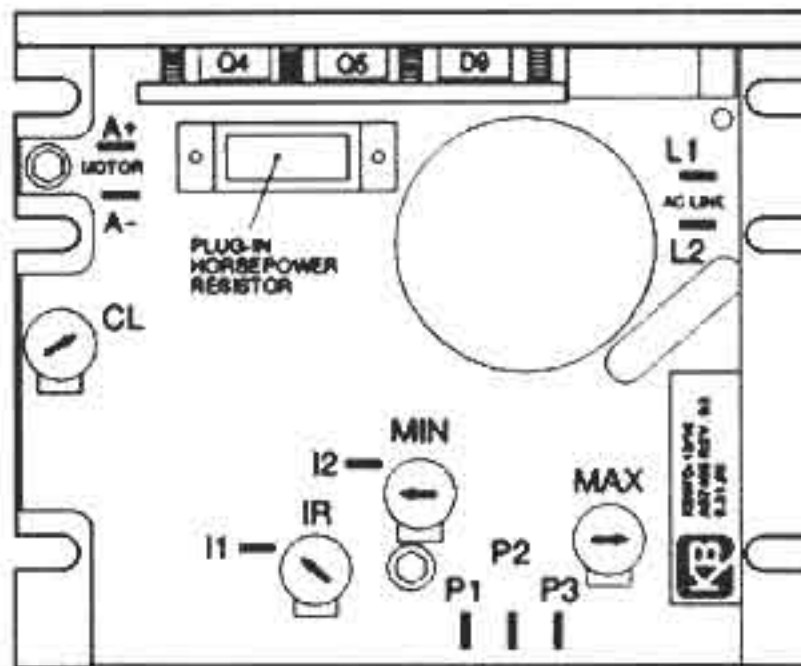
# INSTALLATION AND OPERATING INSTRUCTIONS

This Manual Covers the Following Models

MODEL NO.	PART NO.
KBWD - 13	8609
KBWD - 16	8607



See Safety Warning and Application  
Note Warning on Pages 1 and 2



- Model No. KBWD-13 P/N 8609  
Rated 3.0 amps DC @ 120 VAC 50/60 Hz
- Model No. KBWD-16 P/N 8607  
Rated 6.0 amps DC @ 120 VAC 50/60 Hz

**PENTA KB POWER™**

Spec Tech Industrial 203 Vest Ave. Valley Park, MO 63088 Phone: 888 SPECTECH  
Email: sales@spectechind.com www.spectechind.com

©1996 KB Electronics, Inc.

## TABLE OF CONTENTS

<u>Section</u>	<u>Page</u>
i. Safety Warning	1
ii. Simplified Instructions	1
iii. Application Note: <b>Warning</b>	2
I. General Information	2
II. Installation Instructions	5
III. Operation	8
IV. Trimpot Adjustments	8
V. Limited Warranty	14
<b>TABLES</b>	
1. Specifications	3
2. Ratings	3
3. Plug-in Horsepower Resistor® Chart	4
4. Parts List	11,12
<b>FIGURES</b>	
1. Factory Setting of Trimpots	1
2. Mechanical Specifications	5
3. AC Line and Motor Connection Diagram	6
4. General Connection Diagram	7
5A. Remote Potentiometer Connection	8
5B. Analog Voltage Connection	8
5C. Microprocessor Connection	8
6. Schematic	10



## i. SAFETY WARNING! - PLEASE READ CAREFULLY

This product should be installed and serviced by a qualified technician, electrician or electrical maintenance person familiar with its operation and the hazards involved. Proper installation which includes wiring, mounting in proper enclosure, fusing or other overcurrent protection and grounding, can reduce the chance of electric shocks, fires or explosion in this product or products used with this product, such as electric motors, switches, coils, solenoids and/or relays. Eye protection must be worn and insulated adjustment tools must be used when working with control under power. This product is constructed of materials (plastics, metals, carbon, silicon, etc.) which may be a potential hazard. Proper shielding, grounding and filtering of this product can reduce the emission of radio frequency interference (RFI) which may adversely affect sensitive electronic equipment. If information is required on this product, contact our factory. It is the responsibility of the equipment manufacturer and individual installer to supply this safety warning to the ultimate user of this product. (SW effective 11/92)

This control contains electronic Start/Stop and inhibit circuits that can be used to start and stop the control. However, these circuits are never to be used as safety disconnects since they are not fail-safe. Use only the AC line for this purpose.

The input circuits of this control (potentiometer, inhibit) are not isolated from AC line. Be sure to follow all instructions carefully. Fire and/or electrocution can result due to improper use of this product.

## ii. SIMPLIFIED INSTRUCTIONS

**Important:** Read these simplified instructions before operating control. (See Safety Warning.)

1. Be sure AC line voltage is 120 VAC 50/60 Hz which corresponds to the KBWD™ rated voltage.
2. Install the correct Plug-in Horsepower Resistor® according to motor current and or horsepower.

**Note: Disregard the horsepower rating marked on the Plug-in Horsepower Resistor® since it is not correct for PWM controls.**

3. Recheck connections: AC line to L1 and L2; armature to A+ and A-. (Note: If motor runs in improper direction, Interchange armature leads.)
4. Nominal factory trimpot settings are as follows: (Shown in % of full CW rotation)(See Fig. 1 above.)

FIG. 1 - FACTORY SETTING OF TRIMPOTS



### iii. APPLICATION NOTE:



### WARNING!

1. PWM controls are designed with power transistors wired directly in series with the motor. If for some reason this transistor short circuits, a "runaway" condition could develop where the motor will almost instantaneously accelerate to full speed. This could cause physical harm to an operator or user of the machinery or equipment on which the control is installed. In some cases a proper sized fuse, when installed in series with the motor armature, will prevent this "runaway" condition. Use extreme caution when applying PWM controls to certain applications. KB has available a protective device "PSM" which is designed to prevent "runaway."
2. PWM controls emit substantial levels of radio frequency interference (RFI) compared to SCR controls. KB has available RFI filters which will eliminate most of the RFI. However, RFI can still be radiated and conducted from the control and through the motor wires. Shielded cables and other means of reducing the effect of RFI may have to be employed for some applications.
3. This control may contain inhibit, enable and other circuits that can be used to turn control "on" and "off." **Do not use these circuits as a safety disconnect.** Use only the AC line for that purpose.

### i. GENERAL INFORMATION

#### Product Description.

The KBWD Pulse Width Modulated (PWM) PM DC motor speed control provides excellent dynamic response to load variations. The efficient PWM waveform produces an almost pure DC current to the motor (form factor < 1.05) which has several advantages over a conventional SCR control. The PWM significantly lowers audible motor noise and provides longer brush life. It also produces less motor heating which allows a smaller, less costly motor to be used for most applications. Another advantage of PWM is higher output which provides increased output speed. In addition, the KBWD contains pulse-by-pulse current sensing which provides short circuit protection and prevents control damage due to shorted motors.

A unique feature of the KBWD control is the Plug-in Horsepower Resistor<sup>®</sup>. It eliminates the need for recalibrating IR Comp and Current Limit when the control is used on various horsepower motors. The control contains armature feedback which provides excellent load regulation.

The control contains quick disconnect terminals as standard. A potentiometer (5K), isolated analog signal (0-5 VDC), or PWM microprocessor output can be used to vary the output of the control.

**TABLE 1 - SPECIFICATIONS**

Parameter	Units	Specification	Factory Setting
Speed Range	Ratio	50:1	----
Operating Frequency	KHz	>16	----
Form Factor	amps RMS/amps DC	<1.05	----
Ambient Operating Temperature Range	°C	0 - 45	----
Load Regulation	% Base Speed	1*	----
ACCEL Range (Non-adjustable)	Seconds	0.2, 1, 2.5, and 6	2.5
MIN Trimpot Range	% Base Speed	0 - 40	0
MAX Trimpot Range	% Base Speed	80 - 140	100
CL Range	% Range Setting	0 - 150	150
IR COMP Trimpot Range	VDC	0 - 25	6
AC Line Voltage Regulation	% Base Speed	±0.5	----
Speed Potentiometer	KΩ	5	----

\*Load regulation data is based on a motor having linear IR Comp. characteristics.

**TABLE 2- RATINGS**

Model	AC Line Input Voltage (VAC-50/60Hz)	DC Output Voltage (VDC)	MAX DC Output Current (ADC)		MAX Motor Horsepower* (HP,(KW))
			@ 100 VDC	@ 130 VDC	
KBWD-13	120	0 - 130	3.5	3.0	1/3, (0.25)
KBWD-16	120	0 - 130	6.0	5.0	1/2, (0.35)

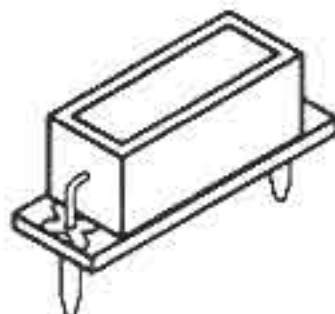
\*Maximum Motor Horsepower is for 90VDC SCR Rated Motors and 130VDC PWM Rated Motors.



## PLUG-IN HORSEPOWER RESISTOR®

A Plug-in Horsepower Resistor® must be installed to match the KBWD to the motor horsepower. See Table 2 for the correct value. Plug-in Horsepower Resistors® are stocked by your distributor.

**Note:** The horsepower ranges marked on the Plug-in Horsepower Resistors® are not correct for PWM controls - See chart.



**CAUTION**  
Be sure Plug-in Horsepower Resistor® is inserted completely into mating socket.

The Plug-in Horsepower Resistor® will match the motor characteristics to the control without having to calibrate the Current Limit (CL) and IR Compensation (IR) for most applications.

**TABLE 3 - PLUG-IN HORSEPOWER RESISTOR® CHART\***

Motor Armature Current (Amps DC)	Plug-in Horsepower Resistor® (OHMS)	90 VDC SCR Rated Motor Horsepower	130 VDC PWM Rated Motor Horsepower
3.3 - 6.0	.1	1/3 - 1/2	1/2
2.5	.18	1/4	1/3
1.3 - 2.0	.25	1/8 - 1/6	1/6 - 1/4
.7 - 1.0	.51	1/15 - 1/10	1/12 - 1/8
.4 - .6	1.0	1/30 - 1/20	1/20 - 1/15
.1 - .3	2.0	1/50 - 1/100	1/30 - 1/50

\* (1) For motor current not on chart use next lowest value Plug-in Horsepower Resistor®

(2) Disregard the horsepower ranges marked on Plug-in Horsepower Resistor® since they are not correct for PWM controls. Refer to resistance value in ohms.

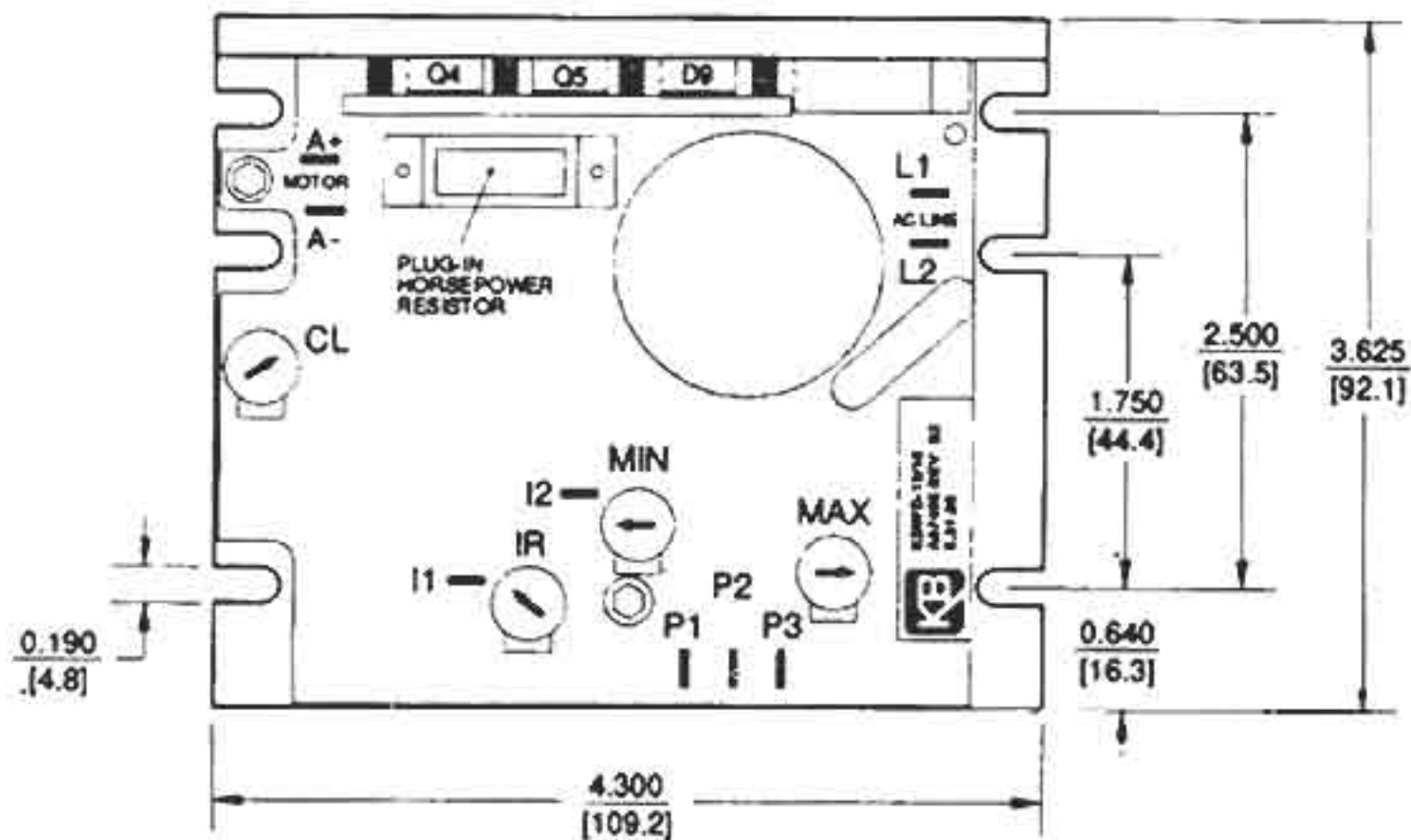
## II. INSTALLATION INSTRUCTIONS

### A. Location and Mounting

The KBWD control should be mounted on a flat surface and located in an area where it will not be exposed to contaminants such as water, metal chips, solvents or excessive vibration. (See Fig. 2 for Mechanical Specifications.)

When mounting in an enclosure, the air space should be large enough to provide adequate heat dissipation. The maximum allowable ambient temperature at full rating is 45°C/113°F. Consult factory if more information is required.

FIG. 2 - MECHANICAL SPECIFICATIONS INCHES  
(MM)



NOTE: MAXIMUM HEIGHT IS  $\frac{2.510}{[63.75]}$

## B. Initial Setup and Wiring.

### i. General Instructions

1. Install proper size Plug-in Horsepower Resistor®. (See chart - Table 3 p. 4.)
2. Connect the KBWD to a standard 120V 50/60Hz AC line. (Be sure the AC input voltage corresponds to the control voltage rating and the motor rating (e.g. 90-130 VDC motor on 120 VAC)).
3. Follow the NEC and other electrical codes that apply.
4. Connect control in accordance to connection diagram - See Fig. 4 p. 7.
5. Ground (earth). The control should be connected to ground (earth) since it contains a metal chassis.
6. When using a step-down transformer (240 VAC to 120 VAC) be sure the VA rating of the transformer is at least 3 times the VA rating of the motor.

### ii. Wiring

1. **AC Line** - Connect AC line (120 VAC 50/60 Hz) to terminals L1 and L2. It is recommended that a line fuse or circuit breaker be installed with a 10 amp - 125 VAC rating. Connect chassis to ground (earth).
2. **Motor Armature** - Connect motor armature to terminals A(+) and A(-). Be sure motor voltage corresponds to control output voltage range (90 - 130 VDC). It is recommended that a fuse be installed in series with the armature; choose a fuse rating equal to the motor rating.
3. **Main Potentiometer** - The control can be operated from a remote potentiometer, or from an isolated analog voltage for voltage following.
  - a. **Remote Potentiometer** - Connect remote potentiometer wires to terminals P1, P2 and P3, so that the "high" side of the potentiometer connects P3, the "wiper" to P2 and the "low" side to P1 (See Fig. 5A p. 8)
  - b. **Analog Input** - An isolated 0-5 VDC or analog voltage can also be used to drive the control. Note: If an isolated signal voltage is not available, an optional signal isolator can be installed (Model KBSI-240D, P/N 9431). Connect the isolated input voltage to terminal P2 (positive) and P1 (negative). (See Fig. 5B p. 8.)

FIG. 3 - AC LINE AND MOTOR CONNECTION DIAGRAM

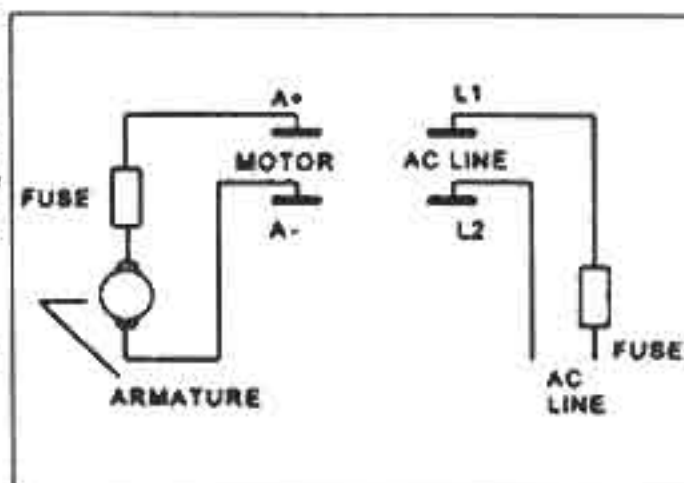
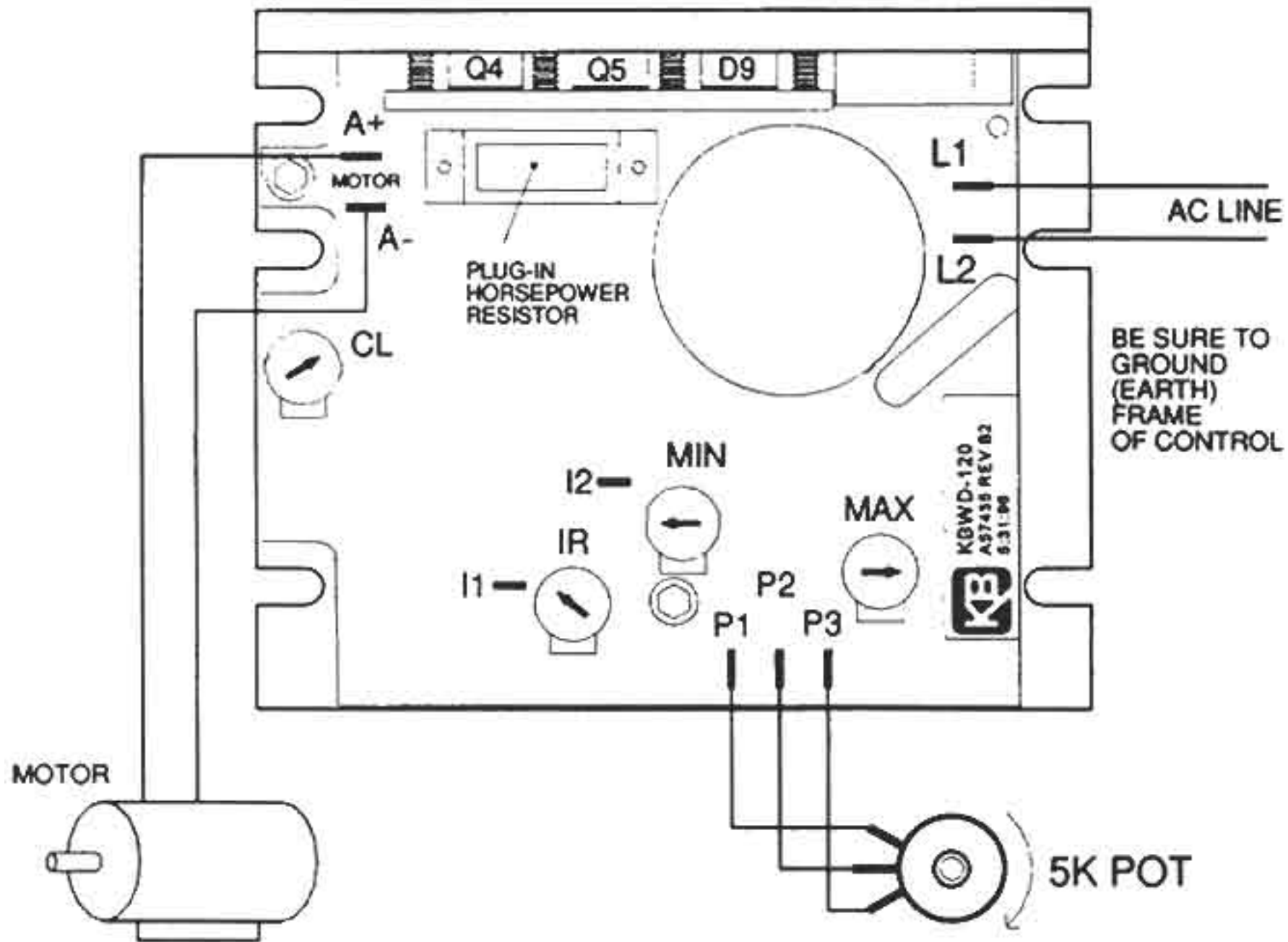





FIG. 4 - GENERAL CONNECTION DIAGRAM



- c. **Microprocessor Input** - An isolated PWM signal from a microprocessor can be used to operate the control. The output frequency should be 200 Hz or greater and should be derived from an optocoupler with a transistor or operational amplifier signal output. (See Fig. 5C)

### III. OPERATION.

 **WARNING!** Read Safety Warning on page 3 before attempting to operate the control or severe injury or death can result.

After the control has been set up properly and the wiring has been completed, the start-up procedure can begin. Before starting, be sure the main potentiometer is in the minimum position. To start the control, the potentiometer knob should be rotated clockwise; the motor should begin to rotate.

**Note:** If the motor rotates in the wrong direction, it will be necessary to disconnect the main AC power and reverse the armature wires.

### IV. TRIMPOT ADJUSTMENTS

The control contains trimpots which have been factory adjusted for most applications. Fig. 1, p.1 illustrates the location of the trimpots and their approximate adjustment positions. Some applications may require readjustment of the trimpots in order to tailor the control to exact requirements. (See Table 1, p. 3 for range and factory setting of all trimpots.) Readjust trimpots as follows:

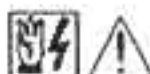
 **WARNING!** Do not adjust trimpots with main power on if possible. If adjustments are made with power on, insulated adjustment tools must be used and safety glasses must be worn. High voltage exists in this control. Electrocutation and/or fire can result if caution is not exercised. Safety warning on pages 1 and 2 must be read and understood before proceeding.

FIG. 5A - REMOTE POTENTIOMETER CONNECTION

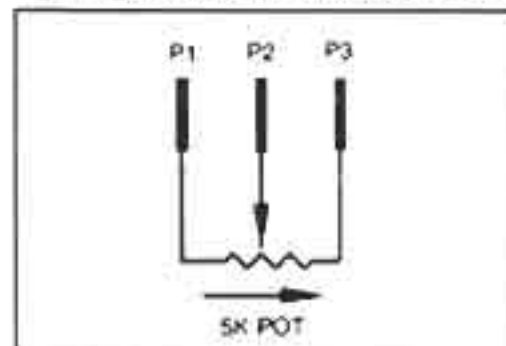


FIG. 5C - MICROPROCESSOR CONNECTION

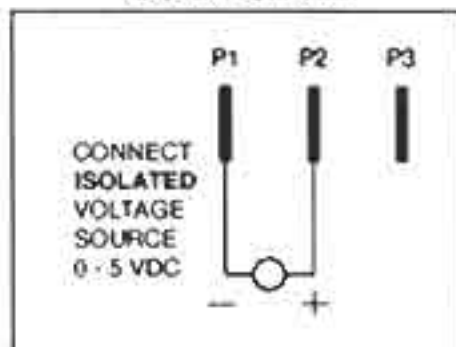
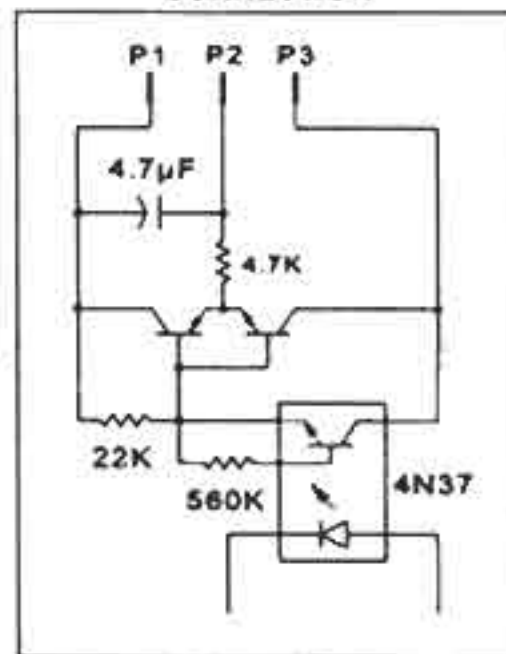


FIG. 5C - MICROPROCESSOR CONNECTION



- A. Minimum Speed (MIN)** - The MIN trimpot is used to set the minimum voltage of the drive. This sets the minimum speed of the motor. Adjust the MIN trimpot as follows:
1. Rotate Main Potentiometer to minimum speed position (full counterclockwise).
  2. Increase setting of MIN trimpot so that motor runs at desired minimum speed.
- B. Maximum Speed (MAX)** - The MAX trimpot is used to set the maximum voltage of the drive. Adjust the MAX trimpot as follows:
1. Rotate Main Potentiometer to maximum speed position (full clockwise).
  2. Adjust MAX trimpot setting to desired setting of motor speed. **(Caution: Do not exceed rated RPM of motor.)**
- C. Current Limit (CL)** - This trimpot is used to set the maximum amount of DC current that the motor can draw. The amount of DC current is directly proportional to the motor torque. The CL trimpot is factory set at 150% of the current established by the Plug-in Horsepower Resistor® selection. (See Table 3, p. 4.) Readjust the CL trimpot as follows:
1. Turn CL trimpot to minimum (CCW) position. Be sure proper value Plug-in Horsepower Resistor® is installed.
  2. Wire in a DC ammeter in series with armature lead. Lock shaft of motor.
  3. Apply power. Rotate CL trimpot CW until desired CL setting is reached (factory setting is 1.5 times rated motor current).

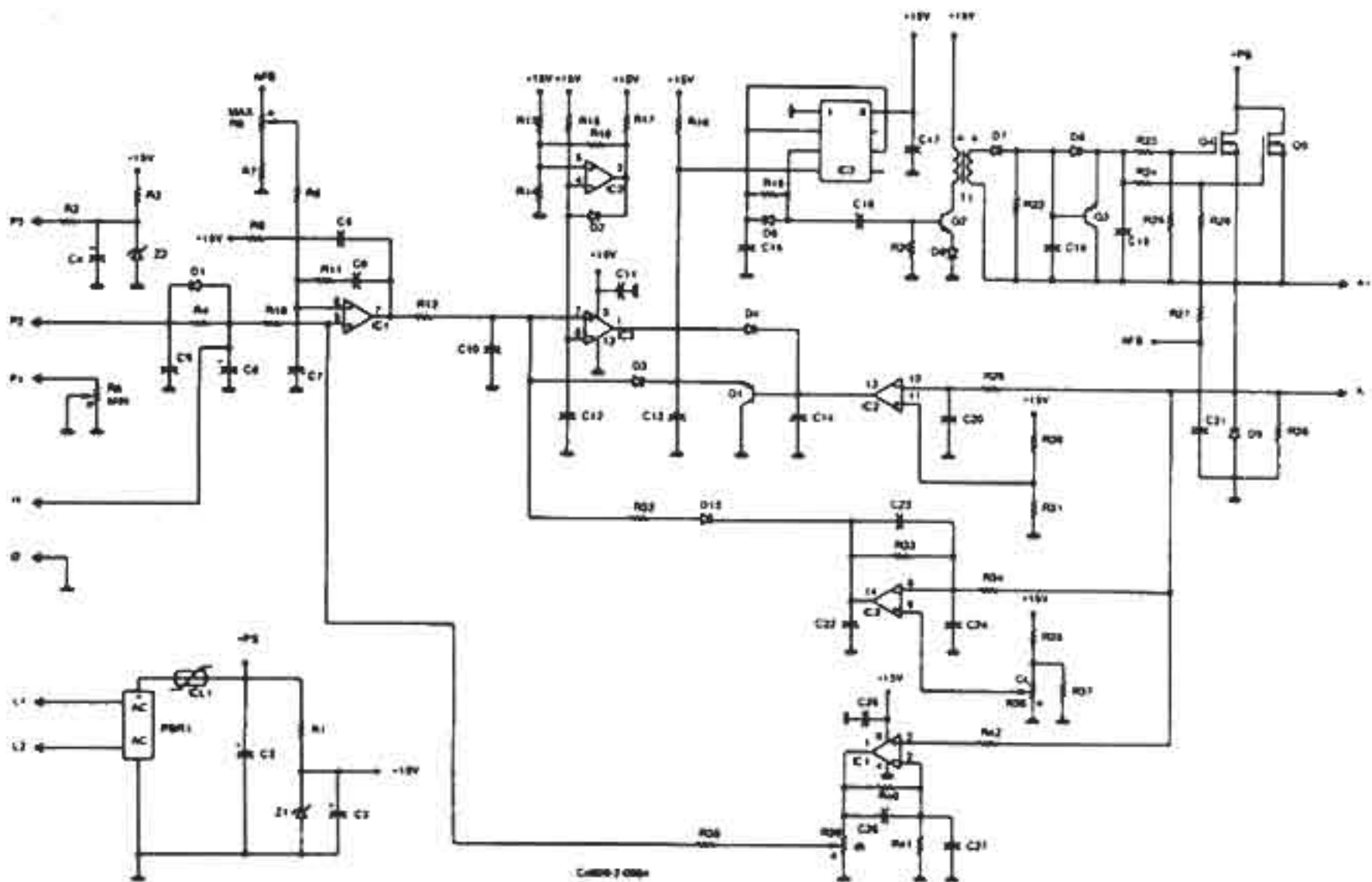
#### **CAUTION**

1. **Adjusting the CL above 150% of motor rating can cause overheating and demagnetization of some PM motors. Consult motor manufacturer.**
  2. **Do not leave the motor in a locked condition for more than a few seconds since armature damage may occur.**
- D. IR Compensation (IR)** - The IR comp circuit is used to stabilize motor speed under varying loads. Readjust the IR trimpot as follows:
1. Run the motor at approximately 30-50% of rated speed under no load and measure actual speed.
  2. Load the motor to rated current. Rotate IR trimpot so that the loaded speed is the same as the unloaded speed measured in 1.
  3. Unload motor and recheck speed. Repeat step 2 if necessary.

Control is now compensated so that minimal speed change will occur over a wide range of motor load. **(Note: Too much IR Comp will cause unstable (oscillatory) operation.)**

**Note:** The horsepower ranges marked on the Plug-in Horsepower Resistor® are not correct for PWM controls. (Use resistance value.) (See Table 3 p. 4.)

FIG. 6 - SCHEMATIC



NOTE: INHIBIT AVAILABLE AS AN OPTION

**TABLE 4 - PARTS LIST KBWD-13 (See Table 4a for KBWD-16)**

<b>Ckt Ref</b>	<b>Specification</b>	<b>Manufacturer-Type</b>	<b>Description</b>
C2	820 $\mu$ F-250VDC-20%	81DA	Bus Capacitor
C3	100 $\mu$ F-35V-20%	Electrolytic	Capacitor
C4	0.47 $\mu$ F-50V-20%	Electrolytic-NP	Capacitor
C5	0.022pF-50V-20%	Multilayer Ceramic	Capacitor
C6	0.1 $\mu$ F-50V-20%	Multilayer Ceramic	Capacitor
C7,10,12,16,18,19,22,27	1000pF-50V-10%	Multilayer Ceramic	Capacitor
C8 <sup>1</sup>	15 $\mu$ F-35V-20%	Electrolytic	Accel/Decel Capacitor
C9,11,14,24,25	0.01 $\mu$ F-50V-30%	Ceramic Tubular	Capacitor
C13,15,23	100pF-50V-10%	Multilayer Ceramic	Capacitor
C17	0.1 $\mu$ F-50V-20%	Metallized Film	Capacitor
C20	220pF-50V-10%	Multilayer Ceramic	Capacitor
C21	0.01 $\mu$ F-500V-20%	Ceramic Disc	Capacitor
C26	0.01 $\mu$ F-50V-20%	Multilayer Ceramic	Capacitor
D1-8,13	0.15A-100PIV	1N4148	Diode
D9	8A-600PIV	FESF8JT	Fast Diode
ICL1	0.5 - 16A	KCC:CL100	Inrush Current Limiter
IC1	-----	LM358P	Dual Op Amp
IC2	-----	LM339N	Quad Comparator
IC3	-----	TLC555	Timer
PBR1	8A-400PIV	KBU8G	Power Bridge
Q1,3	600mA-40V	2N4403	Bipolar Transistor
Q2	600mA-40V	2N4401	Bipolar Transistor
Q4	200V-18A	IR:IRF640	Power Mosfet
R1	4.3K-7W/70°C-5%	-----	Resistor
R2,19,22	2.2K-0.25W-5%	Carbon Film	Resistor
R3,20	4.7K-0.25W-5%	Carbon Film	Resistor
R4,8,12,40	47K-0.25W-5%	Carbon Film	Resistor
R5	2.5K-0.15W-20%	Carbon(PT10LV)	MIN Trimpot
R6	10K-0.15W-20%	Carbon (PT10LV)	MAX Trimpot



**TABLE 4 - PARTS LIST KBWD-13 (continued)**

<b>Ckt Ref</b>	<b>Specification</b>	<b>Manufacturer-Type</b>	<b>Description</b>
R7	7.5K-0.25W-5%	Carbon Film	Resistor
R9	3.3M-0.25W-5%	Carbon Film	Resistor
R10,18,25,26,30,32,35,41,42	10K-0.25W-5%	Carbon Film	Resistor
R11	560K-0.25W-5%	Carbon Film	Resistor
R13	33K-0.25W-5%	Carbon Film	Resistor
R14,16,17	22K-0.25W-5%	Carbon Film	Resistor
R15	100K-0.25W-5%	Carbon Film	Resistor
R23,24	47-0.25W-5%	Carbon Composition	Resistor
R27	330K-0.25W-5%	Carbon Film	Resistor
R28 <sup>1</sup>	5W/70°C-5%	-----	PHR
R29	3.3K-0.25W-5%	Carbon Film	Resistor
R31	1.2K-0.25W-5%	Carbon Film	Resistor
R33	4.7M-0.25W-5%	Carbon Film	Resistor
R34	3.3K-0.25W-5%	Carbon Film	Resistor
R36	10K-0.15W-20%	Carbon (PT10LV)	CL Trimpot
R37	750-0.25W-5%	Carbon Film	Resistor
R38	100K-0.25W-5%	Carbon Film	Resistor
R39	10K-0.15W-20%	Carbon (PT10LV)	IR Trimpot
T1	1:1	-----	Pulse Transformer
Z1	15V-1W-5%	1N4744A	Zener Diode
Z2	7.5V-0.5W-1%	1N5236B	Zener Diode

<sup>1</sup> Component whose value and/or rating may change with application.

**TABLE 4a - COMPONENT CHANGES REQUIRED FOR KBWD-16**

C2	1500µF-250VDC-20%	81DA	Bus Capacitor
Q5 (To be added)	200V-18A	URF640	Power Mosfet

## V - LIMITED WARRANTY

For a period of 18 months from date of original purchase, KB will repair or replace without charge devices which our examination proves to be defective in material or workmanship. This warranty is valid if the unit has not been tampered with by unauthorized persons, misused, abused, or improperly installed and has been used in accordance with the instructions and/or ratings supplied. The foregoing is in lieu of any other warranty or guarantee expressed or implied, and we are not responsible for any expense, including installation and removal, inconvenience, or consequential damage, including injury to any person, caused by items of our manufacture or sale. Some states do not allow certain exclusions or limitations found in this warranty so that they may not apply to you. In any event, KB's total liability, under all circumstances, shall not exceed the full purchase price of this unit. (rev 4/88)



**KB ELECTRONICS, INC.**

12095 NW 39th Street, Coral Springs, FL 33065 • (954) 346-4900 • Fax (954) 346-3377

Outside Florida Call TOLL FREE (800) 221-6570 • Email - info@kbelectronics.com

www.kbelectronics.com

Rev. A (A40274)

PC 1M 09/99