

KBWS

PULSE WIDTH MODULATED (PWM) WHISPER-DRIVE™ DC Motor Speed Controls with Built-in Input Signal Isolation

For Permanent Magnet DC Motors Rated:

1/50 – 1/2 HP (SCR), 3/4 HP (PWM) @ 115 Volts AC
1/25 – 1 HP (SCR), 1½ HP (PWM) @ 208/230 Volts AC

TYPICAL APPLICATIONS

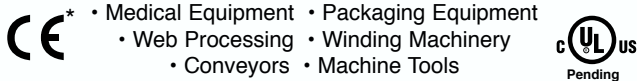

• Medical Equipment • Packaging Equipment
• Web Processing • Winding Machinery
• Conveyors • Machine Tools

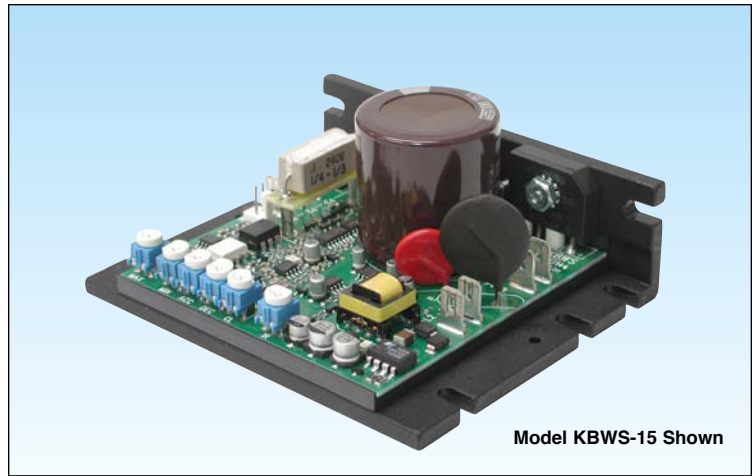

Model KBWS-15 Shown

BENEFITS

- Replaces costly choke and capacitor filtering.
- Provides quieter and cooler operation.
- Extended brush life on SCR rated motors.

STANDARD FEATURES

- **Plug-in Horsepower Resistor®:** Automatically calibrates IR Compensation and Current Limit (supplied separately).
- **Diagnostic LEDs:** Power On (PWR ON) and Current Limit (CL).
- **Short Circuit Protection:** Protects the control from a short circuit at the motor.
- **Isolated Signal Input Circuit:** Eliminates the need for an external signal isolator (accepts 0 - 5 Volts DC input).
- **Protection Features:** Undervoltage protection. MOV input transient protection. AC line inrush current limit protection.
- **Inhibit Circuit:** Provides electronic coast-to-stop.
- **Auto AC Line Select:** Control automatically adjusts for 115 or 208/230 Volt AC line input (dual voltage models).
- **Motor Voltage Selection:** Allows motor voltage to be set to 90/130 or 180 Volts DC (dual voltage models).

TRIMPOT ADJUSTMENTS

- **Maximum Speed (MAX)** • **Minimum Speed (MIN)**
- **Acceleration (ACC)** • **Deceleration (DEC)**
- **Current Limit (CL)** • **IR Compensation (IR)**

OPTIONAL ACCESSORIES

- **DIN Rail Mounting Kit (P/N 9995):** Allows mounting of the control to a DIN Rail.
- **Product Safety Module (PSM) (P/N 8611):** Protects the machine operator from injury due to a runaway or uncontrolled acceleration condition.
- **AC Line / Armature Fuse Kit (P/N 9849)**

Note: * Requires CE RFI filter KBRF-300 (KB P/N 9484) or equivalent.

DESCRIPTION

The KBWS PWM (pulse width modulated) controls are designed to operate PWM and SCR rated Permanent Magnet motors ranging from 1/50 HP to 1½ HP. They operate at a switching frequency greater than 16 kHz to provide high motor efficiency and quiet operation. Another advantage of PWM is higher output voltage (up to 130 Volts DC for 115 Volt AC line and 220 Volts DC for 208/230 Volt AC line) which provides increased motor speed.

The KBWS contains pulse-by-pulse current sensing, which provides short circuit protection and prevents control damage due to commutator arcing. Permanent magnet motor demagnetization is completely eliminated because current peaks are reduced to safe levels. The controls contain an AC line inrush current limiter (ICL) which reduces the AC line surge current during startup.

Standard features of the KBWS include diagnostic LEDs (Power On and Current Limit) and adjustable trimpots (Maximum Speed, Minimum Speed, Acceleration, Deceleration, Current Limit and IR Compensation). Also provided is a connector for an Inhibit Switch and quick-connect terminals for AC line, motor armature and Main Speed Potentiometer. The Plug-In Horsepower Resistor® matches the motor characteristics to the control which eliminates the need to recalibrate the Current Limit (CL) and IR Compensation (IR) trimpots.

The KBWS contains built-in isolation for all inputs. This includes signal voltage, Main Speed Potentiometer, Inhibit Circuit and +5VDC Power Supply. The dual voltage models contain a jumper to select motor voltage and special circuitry which automatically accepts AC line input voltages of 115 or 208/230 Volts AC without having to make a jumper selection.

Optional accessories for the KBWS include a DIN Rail Mounting Kit, a Product Safety Module (PSM) and an AC Line / Armature Fuse Kit.

See **SAFETY WARNING** on reverse side.

PENTA KB POWER™

Spec Tech Industrial 203 Vest Ave. Valley Park, MO 63088 Phone: 888 SPECTECH
Email: sales@spectechind.com www.spectechind.com

GENERAL PERFORMANCE SPECIFICATIONS

Parameter	Specification	Factory Setting
AC Line Voltage Regulation (% Base Speed)	0.5	—
Armature Voltage Range at 115 Volt AC Line Input (Volts DC)	0 – 130	90
Armature Voltage Range at 208/230 Volt AC Line Input (Volts DC)	0 – 130, 0 – 220	180
Maximum Load Capacity (% for 2 Minutes)	150	—
Switching Frequency at Motor (kHz)	>16	—
Signal Following Input Voltage Range (Volts DC)	0 – 5	—
Maximum Speed Trimspot (MAX) Range (% Base Speed)	70 – 100	100
Minimum Speed Trimspot (MIN) Range (% Base Speed)	0 – 30	0
Acceleration Trimspot (ACC) Range (Seconds)	0.2 – 10	1
Deceleration Trimspot (DEC) Range (Seconds)	0.2 – 10	1
Current Limit Trimspot (CL) Range (% Full Load)	0 – 200	150
IR Compensation Trimspot (IR) Range at 90/130 Volts DC Output (Volts DC)	0 – 10	5
IR Compensation Trimspot (IR) Range at 180/220 Volts DC Output (Volts DC)	0 – 20	10
Speed Regulation (50:1 Speed Range) (% Base Speed)	1	—
Speed Range (Ratio)	50:1	—
Operating Temperature Range (°C)	0 – 45	—

ELECTRICAL RATINGS

Model	Part No.	AC Line Input Voltage (±10%, 50/60Hz) (Single Phase Volts AC)	Motor Voltage (Volts DC)	Maximum AC Line Current (Amps AC)	Maximum Load Current (Amps DC)	Maximum Horsepower Rating HP, (kW)	
						SCR Rated Motors	PWM Rated Motors
KBWS-12*	9490	115	0 - 90, 130	4.0	2.5	1/4, (0.18)	1/3, (0.25)
KBWS-15*	9491	115	0 - 90, 130	8.0	5.0	1/2, (0.37)	3/4, (0.5)
KBWS-22D*	9492	115	0 - 90, 130	4.0	2.5	1/4, (0.18)	1/3, (0.25)
		208/230	0 - 180, 220	4.0	2.5	1/2, (0.37)	3/4, (0.5)
KBWS-25D	9493	115	0 - 90, 130	8.0	5.0	1/2, (0.37)	3/4, (0.5)
		208/230	0 - 180, 220	8.0	5.0	1, (0.75)	1½, (1)
		208/230	0 - 90, 130	8.0	5.0	1/2, (0.37)	3/4, (0.5)

* Minimum order, 100 pieces.

PLUG-IN HORSEPOWER RESISTOR® SELECTION CHART

Motor Current (Amps DC)	SCR Rated Motor Horsepower Ranges [HP, (kW)]		PWM Rated Motor Horsepower Ranges [HP, (kW)]		Plug-in Horsepower Resistor®	
	90 Volt DC	180 Volt DC	130 Volt DC	200 Volt DC	Ω	Part No.
3.3 – 5.0	1/3, (0.25) – 1/2, (0.37)	3/4, (0.5) – 1, (0.75)	1/2, (0.37) – 3/4, (0.5)	1, (0.75) – 1½, (1)	0.1	9838
2.5	1/4, (0.18)	1/2, (0.37)	1/3, (0.25)	3/4, (0.5)	0.18	9837
1.3 – 2.0	1/8, (0.09) – 1/6, (0.1)	1/4, (0.18) – 1/3, (0.25)	1/6, (0.1) – 1/4, (0.18)	1/3, (0.25) – 1/2, (0.37)	0.25	9836
0.7 – 1.0	1/15, (0.05) – 1/10, (0.08)	1/6, (0.1) – 1/5, (0.15)	1/12, (0.06) – 1/8, (0.09)	1/6, (0.1) – 1/4, (0.18)	0.51	9834
0.4 – 0.6	1/30, (0.02) – 1/20, (0.04)	1/15, (0.05) – 1/10, (0.08)	1/20, (0.04) – 1/15, (0.05)	1/8, (0.09) – 1/6, (0.1)	1.0	9833
0.1 – 0.3	1/100, (0.007) – 1/50, (0.01)	1/50, (0.01) – 1/25, (0.03)	1/50, (0.01) – 1/30, (0.02)	1/25, (0.03) – 1/20, (0.04)	2.0	9949

MECHANICAL SPECIFICATIONS (Inches / [mm])

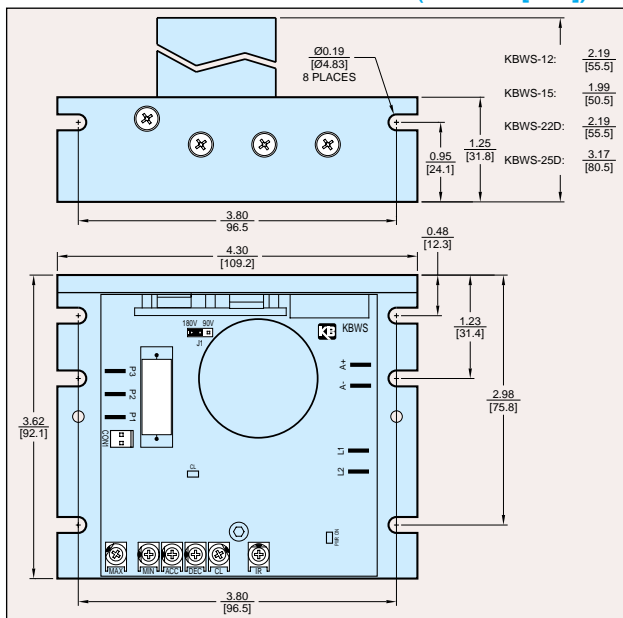

CONTROL LAYOUT & CONNECTION DIAGRAM

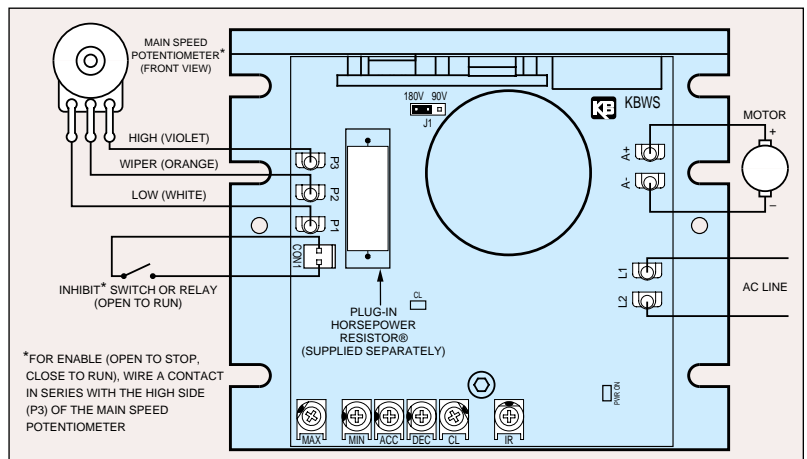

⚠️ PWM SAFETY WARNING! This control does not contain protection circuitry to prevent full speed runaway in the event of main power transistor failure. However, an optional Product Safety Module (PSM) (P/N 9995) can be installed to prevent full speed runaway. If a PSM is not used, the installer of this product should take proper precautions to include other means, such as mechanical disconnects, warning notices, etc., to protect the operator of the machine involved.

Application Note: This control is not recommended for applications where the AC line is to be rapidly cycled on and off.



KB ELECTRONICS, INC.

12095 NW 39th Street, Coral Springs, FL 33065-2516 • (954) 346-4900 • Fax (954) 346-3377

Outside Florida Call **TOLL FREE** (800) 221-6570 • **E-mail** – info@kbelectronics.com

www.kbelectronics.com

(A42105) – Rev. A – 2/2001