

Type PSS Softstarters

ABB Softstarters
Type PSS



6

General information

ABB low voltage softstarters now cover the whole range from 3A to 1250A. The new PSS line brings a wide array of benefits for smaller motors in a flexible, compact form.

Compact line

PSS03 to PSS25 softstarters are a very compact solution for starting small motors with rated current from 3 to 25A. They are suitable for 230, 400, 500 and 600V and designed for DIN rail mounting.

The built-in bypass contacts allow you to build space-saving, compact designs.

Adjustable parameters include acceleration time and initial voltage for starting and deceleration time for stopping. In addition, these units cover a control voltage range of 24 – 110 VAC/DC and 100V – 277 VAC.

UL File # E161428

Flexible line

PSS18/30 to PSS300/515 softstarters provide a flexible solution for motor starting. Rated motor currents are covered from 18A to 300A when connected in line like a traditional full voltage starter. These units can also be wired inside the motor-delta, like a wye-delta starter, covering motors up to 515A. This flexibility makes it easier than ever before to replace wye-delta starters.

The total solid state solution — with no moving contacts in the power circuit — is an attractive solution for applications with many starts per hour. Adjustable parameters include acceleration time, initial voltage and optional current limit for starting and deceleration time for stopping.

Class 10 overload protection is standard for Type PSS enclosed softstarters.

UL File # E161428

General information

Catalog number explanation

PSS Open type

PSS - 18/30 - 500 - F ^③

Maximum motor current
when connected in-line

Maximum motor current
when connected inside delta

Control voltage
F - 100V – 120V, 50/60Hz
L - 220V – 240V, 50/60Hz

Line voltage
500: 208V – 500V
690: 575V – 690V

6

PSS Enclosed type

P 18 D F 1 - 48 A A

Soft starter
PSS enclosed

Softstarter amps
18 60 175
30 72 250
37 85 300
44 105
50 142

Connection type
L: Inline
D: Inside delta

Combination type
No digit – non-combination
F – fusible disconnect
B – thermal magnetic circuit breaker
M – magnetic only breaker

Enclosure
1 – NEMA 1
2 – NEMA 12 ^②
3 – NEMA 3R ^②
4 – NEMA 4 ^②
X – NEMA 4x stainless steel ^②

Options ^①
A – Start-stop pushbutton
B – Across the line rated (AC3) contactor with emergency bypass control
C – 2 position selector switch
D – 3 position selector switch
E – Pilot light
F – Start-stop pushbutton and pilot light
H – 2 position selector switch and pilot light
J – 3 position selector switch and pilot light
M – Shunt rated (AC1) bypass contactor
W – Isolation contactor

Fuse clip
A – 30A, 600V, Class J
B – 60A, 600V, Class J
C – 100A, 600V, Class J
D – 200A, 600V, Class J
E – 400A, 600V, Class J
F – 600A, 600V, Class J
G – 800A, 600V, Class L

Circuit breaker amp ratings
D – 15 M – 70 W – 225 E – 700
E – 20 N – 80 X – 250
F – 25 P – 60 Y – 300
G – 30 R – 100 Z – 350
H – 35 S – 125 A – 400
J – 40 T – 150 B – 450
K – 50 U – 175 C – 500
L – 60 V – 200 D – 600

MCP/MAG only rating
A – 3 E – 50 J – 400
B – 5 F – 100 K – 600
C – 10 G – 150 L – 800
D – 25 H – 225

Line voltage
20: 208V 120V control voltage
23: 230V 120V control voltage
38: 380V 220V control voltage
41: 415V 220V control voltage
48: 480V 120V control voltage
60: 600V 120V control voltage

^① For more options, see page 6.8

^② Bypass contactor required.

^③ See page 6.3 for the PSS03, PSS12 & PSS25 softstarters.

Open 3A – 25A

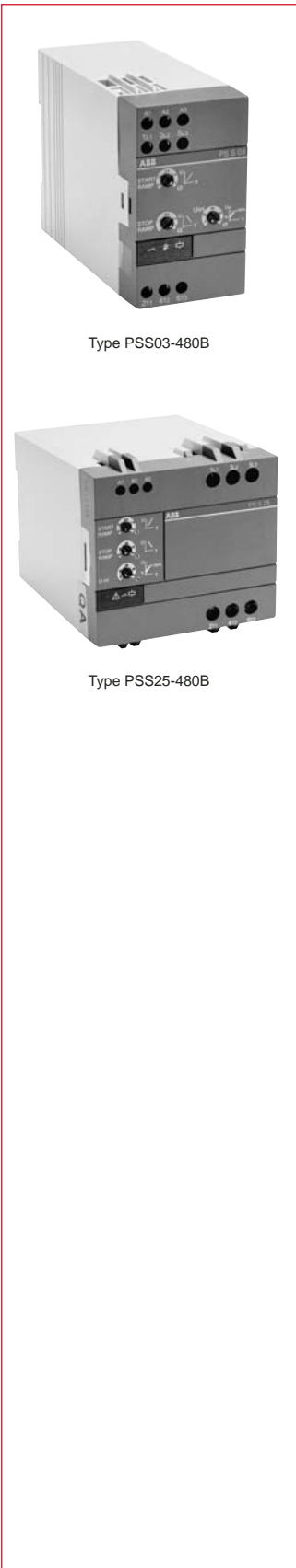

Type PSS03-480B

Type PSS25-480B

PSS Open type ①②

Operating voltage 50Hz – 60Hz	Maximum HP rating three phase	Maximum current amperes	Catalog number	List price
220 – 240V	0.5	3	PSS03-220B	\$ 270
	3	12	PSS12-220B	345
	7.5	25	PSS25-220B	405
380 – 415V	1	3	PSS03-400B	270
	5	12	PSS12-400B	345
	10	25	PSS25-400B	405
440 – 480V	1.5	3	PSS03-480B	270
	7.5	12	PSS12-480B	345
	15	25	PSS25-480B	405
550 – 600V	10	12	PSS12-600B	375
	20	25	PSS25-600B	445

6

① Overload protection not included; external overload relay must be in power circuit. Use ABB TA series overload.
 ② See page 6.12 for single phase wiring schematic.

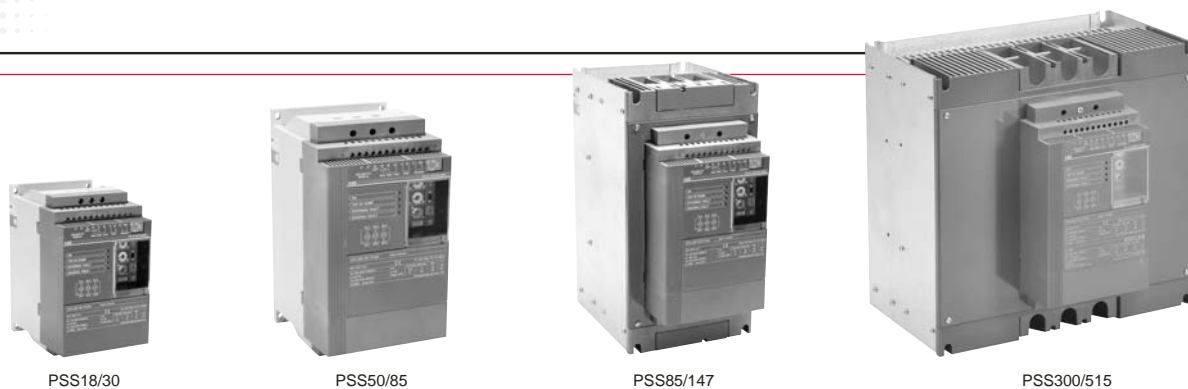

6

Connected inline ①②③

Maximum motor current		Maximum horsepower					Weight (lbs.)	Catalog number	List price
UL	IEC	208V	240V	380V	480V	600V			
18	18	5	5	10	10	15	PSS18/30-500F PSS18/30-690F	\$ 620 744	
28	30	7.5	10	15	20	25	PSS30/52-500F PSS30/52-690F	680 820	
34	37	10	10	20	25	30	PSS37/64-500F PSS37/64-690F	750 900	
40	44	10	10	25	30	30	PSS44/76-500F PSS44/76-690F	900 1080	
47	50	15	15	25	30	40	PSS50/85-500F PSS50/85-690F	1120 1345	
56	60	15	20	30	40	50	PSS60/105-500F PSS60/105-690F	1325 1590	
67	72	20	20	40	50	60	PSS72/124-500F PSS72/124-690F	1460 1750	
85	85	25	30	50	60	75	PSS85/147-500F PSS85/147-690F	1650 1980	
105	105	30	40	60	75	100	PSS105/181-500F PSS105/181-690F	1700 2040	
125	142	40	40	75	100	125	PSS142/245-500F PSS142/245-690F	2250 2700	
156	175	50	60	100	125	150	PSS175/300-500F PSS175/300-690F	2900 3395	
225	250	75	75	150	150	200	PSS250/430-500F PSS250/430-690F	3400 3965	
248	300	75	100	150	200	250	PSS300/515-500F PSS300/515-690F	3950 4530	

Connected inside delta ①②③

30	30	7.5	10	15	20	25	PSS18/30-500F PSS18/30-690F	\$ 620 744
48	52	15	15	30	30	40	PSS30/52-500F PSS30/52-690F	680 820
58	64	20	20	30	40	50	PSS37/64-500F PSS37/64-690F	750 900
69	76	20	25	40	50	60	PSS44/76-500F PSS44/76-690F	900 1080
81	85	25	30	50	60	75	PSS50/85-500F PSS50/85-690F	1120 1345
96	105	30	30	60	75	75	PSS60/105-500F PSS60/105-690F	1325 1590
116	124	40	40	60	75	100	PSS72/124-500F PSS72/124-690F	1460 1750
147	147	50	50	75	100	150	PSS85/147-500F PSS85/147-690F	1650 1980
181	181	60	60	100	150	150	PSS105/181-500F PSS105/181-690F	1700 2040
215	245	75	75	150	150	200	PSS142/245-500F PSS142/245-690F	2250 2700
270	300	75	100	150	200	250	PSS175/300-500F PSS175/300-690F	2900 3395
389	430	125	150	250	300	400	PSS250/430-500F PSS250/430-690F	3400 3965
429	515	150	150	300	350	400	PSS300/515-500F PSS300/515-690F	3950 4530

NOTE: Open softstarters are converted from connected inline to connected inside delta by means of a DIP switch. See circuit diagram on pages 6.13 - 6.15 for information.

① Catalog numbers are shown with 120V control. For 240V control, replace "F" with "L" in catalog number.

② Overload protection not included; external overload relay must be in power circuit. Use ABB TA series overload.

③ Current transformer not included. See page 6.8 for current transformers.

Enclosed ① NEMA 1, 12



Connected inline

Maximum motor current		Maximum horsepower					NEMA 1, 480V		NEMA 1, 600V		NEMA 12, 480V ②		NEMA 12, 600V ②	
UL	IEC	208V	240V	380V	480V	600V	Catalog number	List price	Catalog number	List price	Catalog number	List price	Catalog number	List price
18	18	5	5	10	10	—	P18L1-48	\$ 1095	—	—	P18L2-48M	\$ 1395	—	—
						15	—	—	P18L1-60	\$ 1219	—	—	P18L2-60M	\$ 1519
25	—	—	7.5	—	15	—	P22L1-48	1155	—	—	P22L2-48M	1480	—	—
						20	—	—	P22L1-60	1295	—	—	P22L2-60M	1620
28	30	7.5	10	15	20	—	P30L1-48	1155	—	—	P30L2-48M	1480	—	—
						25	—	—	P30L1-60	1295	—	—	P30L2-60M	1620
34	37	10	10	20	25	—	P37L1-48	1325	—	—	P37L2-48M	1725	—	—
						30	—	—	P37L1-60	1475	—	—	P37L2-60M	1875
40	44	10	10	25	30	—	P44L1-48	1475	—	—	P44L2-48M	1925	—	—
						30	—	—	P44L1-60	1755	—	—	P44L2-60M	2205
47	50	15	15	25	30	—	P50L1-48	1595	—	—	P50L2-48M	2045	—	—
						40	—	—	P50L1-60	1820	—	—	P50L2-60M	2270
56	60	15	20	30	40	—	P60L1-48	1860	—	—	P60L2-48M	2360	—	—
						50	—	—	P60L1-60	2135	—	—	P60L2-60M	2635
67	72	20	20	40	50	—	P72L1-48	1935	—	—	P72L2-48M	2485	—	—
						60	—	—	P72L1-60	2225	—	—	P72L2-60M	2775
85	85	25	30	50	60	—	P85L1-48	2475	—	—	P85L2-48M	3250	—	—
						75	—	—	P85L1-60	2805	—	—	P85L2-60M	3580
105	105	30	40	60	75	—	P105L1-48	2600	—	—	P105L2-48M	3375	—	—
						100	—	—	P105L1-60	2940	—	—	P105L2-60M	3715
125	142	40	40	75	100	—	P142L1-48	3350	—	—	P142L2-48M	4225	—	—
						125	—	—	P142L1-60	3800	—	—	P142L2-60M	4675
156	175	50	60	100	125	—	P175L1-48	3780	—	—	P175L2-48M	5180	—	—
						150	—	—	P175L1-60	4150	—	—	P175L2-60M	5550
225	250	75	75	150	150	—	P250L1-48	4300	—	—	P250L2-48M	5700	—	—
						200	—	—	P250L1-60	4750	—	—	P250L2-60M	6140
248	300	75	100	150	200	—	P300L1-48	4760	—	—	P300L2-48M	6460	—	—
						250	—	—	P300L1-60	5215	—	—	P300L2-60M	6915

6

Connected inside delta

30	30	7.5	10	15	20	—	P18D1-48	\$ 1095	—	—	P18D2-48M	\$ 1395	—	—
						25	—	—	P18D1-60	\$ 1219	—	—	P18D2-60M	\$ 1519
37	—	10	—	—	25	—	P22D1-48	1155	—	—	P22D2-48M	1480	—	—
						30	—	—	P22D1-60	1295	—	—	P22D2-60M	1620
48	52	15	15	30	30	—	P30D1-48	1155	—	—	P30D2-48M	1480	—	—
						40	—	—	P30D1-60	1295	—	—	P30D2-60M	1620
58	64	20	20	30	40	—	P37D1-48	1325	—	—	P37D2-48M	1725	—	—
						50	—	—	P37D1-60	1475	—	—	P37D2-60M	1875
69	76	20	25	40	50	—	P44D1-48	1475	—	—	P44D2-48M	1925	—	—
						60	—	—	P44D1-60	1755	—	—	P44D2-60M	2205
81	85	25	30	50	60	—	P50D1-48	1595	—	—	P50D2-48M	2045	—	—
						75	—	—	P50D1-60	1820	—	—	P50D2-60M	2270
96	105	30	30	60	75	—	P60D1-48	1860	—	—	P60D2-48M	2360	—	—
						75	—	—	P60D1-60	2135	—	—	P60D2-60M	2635
116	124	40	40	60	75	—	P72D1-48	1935	—	—	P72D2-48M	2485	—	—
						100	—	—	P72D1-60	2225	—	—	P72D2-60M	2775
147	147	50	50	75	100	—	P85D1-48	2475	—	—	P85D2-48M	3250	—	—
						150	—	—	P85D1-60	2805	—	—	P85D2-60M	3580
181	181	60	60	100	150	—	P105D1-48	2600	—	—	P105D2-48M	3375	—	—
						150	—	—	P105D1-60	2940	—	—	P105D2-60M	3715
215	245	75	75	150	150	—	P142D1-48	3350	—	—	P142D2-48M	4225	—	—
						200	—	—	P142D1-60	3800	—	—	P142D2-60M	4675
270	300	75	100	150	200	—	P175D1-48	3780	—	—	P175D2-48M	5180	—	—
						250	—	—	P175D1-60	4150	—	—	P175D2-60M	5550
389	430	125	150	250	300	—	P250D1-48	4300	—	—	P250D2-48M	5700	—	—
						400	—	—	P250D1-60	4750	—	—	P250D2-60M	6140
429	515	150	150	300	350	—	P300D1-48	4760	—	—	P300D2-48M	6460	—	—
						400	—	—	P300D1-60	5215	—	—	P300D2-60M	6915

① All enclosed softstarters include a control power transformer and Class 10 overload.
 ② Includes shunt rated (AC1) bypass contactor.

Enclosed ① NEMA 1 Combination

Connected inline

Maximum motor current		Maximum horsepower					480V with fusible disconnect switch NEMA 1		600V with fusible disconnect switch NEMA 1		480V with circuit breaker NEMA 1		600V with circuit breaker NEMA 1		
UL	IEC	208V	240V	380V	480V	600V	Catalog number	List price	Catalog number	List price	Catalog number	List price	Catalog number	List price	
18	18	5	5	10	10	—	P18LF1-48A	\$ 1370	—	—	P18LB1-48E	\$ 1370	—	—	
		—	—	—	—	15	—	—	—	P18LF1-60A	\$ 1709	—	—	P18LB1-60E	\$ 1709
25	—	—	7.5	—	15	—	P22LF1-48B	1580	—	—	P22LB1-48G	1580	—	—	
		—	—	—	—	20	—	—	—	P22LF1-60B	1835	—	—	P22LB1-60G	1835
28	30	7.5	10	15	20	—	P30LF1-48B	1580	—	—	P30LB1-48J	1580	—	—	
		—	—	—	—	25	—	—	—	P30LF1-60B	1835	—	—	P30LB1-60J	1835
34	37	10	10	20	25	—	P37LF1-48B	1750	—	—	P37LB1-48K	1750	—	—	
		—	—	—	—	30	—	—	—	P37LF1-60B	2040	—	—	P37LB1-60K	2040
40	44	10	10	25	30	—	P44LF1-48C	2075	—	—	P44LB1-48L	2075	—	—	
		—	—	—	—	30	—	—	—	P44LF1-60B	2400	—	—	P44LB1-60L	2400
47	50	15	15	25	30	—	P50LF1-48C	2195	—	—	P50LB1-48N	2195	—	—	
		—	—	—	—	40	—	—	—	P50LF1-60C	2565	—	—	P50LB1-60N	2565
56	60	15	20	30	40	—	P60LF1-48C	2460	—	—	P60LB1-48N	2460	—	—	
		—	—	—	—	50	—	—	—	P60LF1-60C	2905	—	—	P60LB1-60N	2905
67	72	20	20	40	50	—	P72LF1-48C	2535	—	—	P72LB1-48R	2535	—	—	
		—	—	—	—	60	—	—	—	P72LF1-60C	3010	—	—	P72LB1-60R	3010
85	85	25	30	50	60	—	P85LF1-48D	3475	—	—	P85LB1-48S	3475	—	—	
		—	—	—	—	75	—	—	—	P85LF1-60D	4060	—	—	P85LB1-60S	4060
105	105	30	40	60	75	—	P105LF1-48D	3600	—	—	P105LB1-48T	3600	—	—	
		—	—	—	—	100	—	—	—	P105LF1-60D	4195	—	—	P105LB1-60T	4195
125	142	40	40	75	100	—	P142LF1-48D	4550	—	—	P142LB1-48V	4550	—	—	
		—	—	—	—	125	—	—	—	P142LF1-60D	5365	—	—	P142LB1-60V	5365
156	175	50	60	100	125	—	P175LF1-48E	5580	—	—	P175LB1-48X	5580	—	—	
		—	—	—	—	150	—	—	—	P175LF1-60E	5950	—	—	P175LB1-60X	5950
225	250	75	75	150	150	—	P250LF1-48E	6100	—	—	P250LB1-48Y	6100	—	—	
		—	—	—	—	200	—	—	—	P250LF1-60E	7900	—	—	P250LB1-60Y	7900
248	300	75	100	150	200	—	P300LF1-48E	6560	—	—	P300LB1-48Z	6560	—	—	
		—	—	—	—	250	—	—	—	P300LF1-60E	8360	—	—	P300LB1-60Z	8360

Connected inside delta

30	30	7.5	10	15	20	—	P18DF1-48B	\$ 1370	—	—	P18DB1-48J	\$ 1370	—	—	
		—	—	—	—	25	—	—	—	P18DF1-60B	\$ 1709	—	—	P18DB1-60J	\$ 1709
37	—	10	—	—	25	—	P22DF1-48B	1580	—	—	P22DB1-48K	1580	—	—	
		—	—	—	—	30	—	—	—	P22DF1-60B	1835	—	—	P22DB1-60K	1835
48	52	15	15	30	30	—	P30DF1-48C	1580	—	—	P30DB1-48L	1580	—	—	
		—	—	—	—	40	—	—	—	P30DF1-60C	1835	—	—	P30DB1-60N	1835
58	64	20	20	30	40	—	P37DF1-48C	1750	—	—	P37DB1-48N	1750	—	—	
		—	—	—	—	50	—	—	—	P37DF1-60C	2040	—	—	P37DB1-60N	2440
69	76	20	25	40	50	—	P44DF1-48C	2075	—	—	P44DB1-48R	2075	—	—	
		—	—	—	—	60	—	—	—	P44DF1-60C	2400	—	—	P44DB1-60R	2400
81	85	25	30	50	60	—	P50DF1-48D	2195	—	—	P50DB1-48S	2195	—	—	
		—	—	—	—	75	—	—	—	P50DF1-60D	2565	—	—	P50DB1-60S	2565
96	105	30	30	60	75	—	P60DF1-48D	2460	—	—	P60DB1-48T	2460	—	—	
		—	—	—	—	75	—	—	—	P60DF1-60D	2905	—	—	P60DB1-60S	2905
116	124	40	40	60	75	—	P72DF1-48D	2535	—	—	P72DB1-48T	2535	—	—	
		—	—	—	—	100	—	—	—	P72DF1-60D	3010	—	—	P72DB1-60T	3010
147	147	50	50	75	100	—	P85DF1-48D	3475	—	—	P85DB1-48V	3475	—	—	
		—	—	—	—	150	—	—	—	P85DF1-60E	4060	—	—	P85DB1-60X	4060
181	181	60	60	100	150	—	P105DF1-48E	3600	—	—	P105DB1-48Y	3600	—	—	
		—	—	—	—	150	—	—	—	P105DF1-60E	4195	—	—	P105DB1-60X	4195
215	245	75	75	150	150	—	P142DF1-48E	4550	—	—	P142DB1-48Y	4550	—	—	
		—	—	—	—	200	—	—	—	P142DF1-60E	5365	—	—	P142DB1-60Y	5365
270	300	75	100	150	200	—	P175DF1-48E	5580	—	—	P175DB1-48Z	5580	—	—	
		—	—	—	—	250	—	—	—	P175DF1-60E	5950	—	—	P175DB1-60Z	5950
389	430	125	150	250	300	—	P250DF1-48F	6100	—	—	P250DB1-48C	6100	—	—	
		—	—	—	—	400	—	—	—	P250DF1-60F	7900	—	—	P250DB1-60D	7900
429	515	150	150	300	350	—	P300DF1-48F	6560	—	—	P300DB1-48D	6560	—	—	
		—	—	—	—	400	—	—	—	P300DF1-60F	8360	—	—	P300DB1-60D	8360

① All enclosed softstarters include control power transformer and Class 10 overload.

Enclosed Options

Softstarters
Type PSS

Connected inline

Maximum motor current		Maximum horsepower					Shunt rated (AC1) bypass or isolation contactor	Across the line rated (AC3) bypass contactor ②③	Electronic brake std. duty	Electronic brake hvy. duty	Start/Stop pushbuttons	HOA selector switch	Run pilot light	NEMA 12 adder ①	NEMA 3R adder ①	NEMA 4 adder ①	NEMA 4X adder ①
UL	IEC	208V	240V	380V	480V	600V	List price	List price	List price	List price	List price	List price	List price	List price	List price	List price	List price
18	30	5	5	10	10	— 15	\$ 150	\$ 775	\$ 1445	\$ 1445	\$ 72	\$ 72	\$ 135	\$ 150	\$ 150	\$ 225	\$ 675
25	—	—	7.5	—	15	— 20	175	850	1445	2175	72	72	135	150	150	225	675
28	30	7.5	10	15	20	— 25	175	850	1445	2175	72	72	135	150	150	225	675
34	37	10	10	20	25	— 30	250	900	2175	2175	72	72	135	150	150	225	675
40	44	10	10	25	30	— 30	300	950	2175	2975	72	72	135	150	150	225	675
47	50	15	15	25	30	— 40	300	950	2175	2975	72	72	135	150	150	225	675
56	60	15	20	30	40	— 50	350	1000	2175	2975	72	72	135	150	150	225	675
67	72	20	20	40	50	— 60	400	1100	2975	2975	72	72	135	150	150	225	675
85	85	25	30	50	60	— 75	500	1150	2975	5800	72	72	135	275	275	350	1150
105	105	30	40	60	75	— 100	500	1150	2975	5800	72	72	135	275	275	350	1150
125	142	40	40	75	100	— 125	600	1550	5800	5800	72	72	135	275	275	350	1150
156	175	50	60	100	125	— 150	950	1850	5800	6500	72	72	135	450	450	525	1575
225	250	75	75	150	150	— 200	950	2100	5800	6500	72	72	135	450	450	525	1575
248	300	75	100	150	200	— 250	1250	2700	6500	7000	72	72	135	450	450	525	1575

6

Connected inside delta

Maximum motor current		Maximum horsepower					Shunt rated (AC1) bypass or isolation contactor	Across the line rated (AC3) bypass contactor ②③	Electronic brake std. duty	Electronic brake hvy. duty	Start/Stop pushbuttons	HOA selector switch	Run pilot light	NEMA 12 adder ①	NEMA 3R adder ①	NEMA 4 adder ①	NEMA 4X adder ①
UL	IEC	208V	240V	380V	480V	600V	List price	List price	List price	List price	List price	List price	List price	List price	List price	List price	List price
30	30	7.5	10	15	20	— 25	\$ 150	\$ 775	\$ 1445	\$ 1445	\$ 72	\$ 72	\$ 135	\$ 150	\$ 150	\$ 225	\$ 675
37	—	10	—	—	25	— 30	175	850	1445	2175	72	72	135	150	150	225	675
48	52	15	15	30	30	— 40	175	850	1445	2175	72	72	135	150	150	225	675
58	64	20	20	30	40	— 50	250	900	2175	2175	72	72	135	150	150	225	675
69	76	20	25	40	50	— 60	300	950	2175	2975	72	72	135	150	150	225	675
81	85	25	30	50	60	— 75	300	950	2175	2975	72	72	135	150	150	225	675
96	105	30	30	60	75	— 75	350	1000	2175	2975	72	72	135	150	150	225	675
116	124	40	40	60	75	— 100	400	1100	2975	2975	72	72	135	150	150	225	675
147	147	50	50	75	100	— 155	500	1150	2975	5800	72	72	135	275	275	350	1150
181	181	60	60	100	150	— 150	500	1150	2975	5800	72	72	135	275	275	350	1150
215	245	75	75	150	150	— 200	600	1550	5800	5800	72	72	135	275	275	350	1150
270	300	75	100	150	200	— 250	950	1850	5800	6500	72	72	135	450	450	525	1575
389	430	125	150	250	300	— 400	950	2100	5800	6500	72	72	135	450	450	525	1575
429	515	150	150	300	350	— 400	1250	2700	6500	7000	72	72	135	450	450	525	1575

① Bypass contactor required.
 ② Includes emergency bypass control.
 ③ Subtract AC1 List price when AC1 rating ("M" suffix) is included in the catalog numbers shown on page 6.5.

Accessories

Accessories

Item	Suffix code ①	List price adder
Softstarters		
Start-stop pushbutton	A	\$ 72
2 position selector switch	C	72
3 position selector switch	D	72
Pilot light run	E	135
Start-stop pushbutton & pilot light	F	207
2 position selector switch & pilot light	H	207
3 position selector switch & pilot light	J	207
Shunt rated (AC1) bypass contactor	M	see pg 6.7
Across the line rated (AC3) contactor with emergency bypass control ②	B	see pg 6.7
Isolation contactor	W	see pg 6.7
Electronic brake (standard duty)	Y	see pg 6.7
Electronic brake (heavy duty)	Z	see pg 6.7
Service entrance, 3-wire	SE3	100
Service entrance, 4-wire	SE4	300
Lightning arrester	LA	320
Space heater, 100W with thermostat	SH	600
Auxiliary relays		
Type N control relay (4 pole)	CR	150
Electronic timer		
1.5 – 30s On Delay	TN30	125
5 – 100s On Delay	TN100	125
1.5 – 30s Off Delay	TF30	125
5 – 100s Off Delay	TF100	125
Phase failure phase reversal	PFPR	375
Undervoltage relay	UV	150
Overvoltage relay	OV	180
Ground fault protection	GFP	1500
Meters & metering		
Current transformer	CT	250
Ammeter (including C.T.)	AM	470
Ammeter & ammeter switch	AMS	1800
Voltmeter	VM	1200
Voltmeter & voltmeter switch	VMS	1800
Elapsed time meter	ETM	350
Operation counter	OC	375
Wattmeter	WM	2450

Control transformers

Size	Standard VA	Price adder for extra VA	
		100VA	250VA
PSS18/30 – PSS 142/245	75	\$ 175	—
PSS175/300 – PSS300/515	150	225	\$ 300

Current transformers for current limit function ②

Technical data	For softstarter	Catalog number	List price
60/1 – 2 turns	PSS18/30	PSCT-60	\$ 70
40/1 – 1 turn	PSS30/52	PSCT-40	
50/1 – 1 turn	PSS37/64	PSCT-50	
60/1 – 1 turn	PSS44/76	PSCT-60	
75/1 – 1 turn	PSS50/85	PSCT-75	130
75/1 – 1 turn	PSS60/105	PSCT-75	
100/1 – 1 turn	PSS72/124	PSCT-100	
125/1 – 1 turn	PSS85/147	PSCT-125	
150/1 – 1 turn	PSS105/181	PSCT-150	
200/1 – 1 turn	PSS142/245	PSCT-200	
250/1 – 1 turn	PSS175/300	PSCT-250	
400/1 – 1 turn	PSS250/430	PSCT-400	
400/1 – 1 turn	PSS300/515	PSCT-400	

① Add the suffix code after the last digit of the catalog number.

② 1 VA minimum.

③ Stranded conductors.

④ Includes line/load lugs and hardware.

⑤ Softstarters listed are provided with terminating bus tabs as standard.

⑥ Discount schedule SA.

Additional auxiliary contact blocks for bypass or isolation contactors

Contact configuration	Suffix code	List Price adder
1 N.O. & 1 N.C.	11	\$ 54
2 N.O. & 2 N.C.	22	98
3 N.O. & 3 N.C.	33	142

Terminal block to increase connection capacity ③

Wire range	For softstarter	Catalog number	List price
#8 - #1 (1 per phase)	PSS18 – PSS44	PSLW-44	\$ 65
#6 - 2/0 (1 per phase) or #4 - 1/0 (2 per phase)	PSS50 – PSS72	PSLW-72	70

Terminal lug kits ④

Wire range	For softstarter ⑤	Catalog number	List price
#6 - 250 MCM (1 per phase)	PSS85 – PSS142	PSLK-185	\$ 150
#4 - 400 MCM (1 per phase)	PSS175 – PSS300	PSLK-300	195
#4 - 500 MCM (2 per phase)	PSS175 – PSS300	PSLK-300/2	280

Terminal covers

For softstarter	Catalog ⑥	List price
PSS85 – PSS142	K4LCH	\$ 16
PSS175 – PSS300	K5LCH	24

Technical data

Softstarters
Type PSS

PSS03 – PSS25 and PSS18/30 – PSS300/515

		PSS03 – PSS12	PSS25	PSS18/30 – PSS300/515
Rated insulation voltage U_z	V	630	630	690
Rated operational Voltage U_e	V	220 – 600	220 – 600	200 – 690
SCR PIV ratings				
up to 500V		1200	1200	1600
up to 600V		1600	1600	1800
Starting capacity at max. rated current I_e		5 x I_e for 5 sec	5 x I_e for 5 sec	500% for 30 sec
Number of starts per hour ¹		6	6	30 ^⑥
Overload class	A	10	10	10
Service factor	%	100	100	115
				110 (PSS300/515)
Ambient temperature				
During operation	°C	-20 to +50	-20 to +50	-20 to +60 ^②
During storage	°C	-40 to +70	-40 to +70	-40 to +70
Degree of protection				
Main circuit		IP20	IP20	IP20 (PSS18/30-500 – PSS44/76-500) IP10 (PSS50/85-500 – PSS72/124/-500) IP10 (PSS18/30-690 – PSS72/124-690) IP00 (PSS85/147 – PSS300/515)
Supply and control circuit		IP20	IP20	IP20
Settings				
Ramp time during start	s	0.5 – 6.5	0.5 – 10	1 – 30
Ramp time during stop	s	0.5 – 8	0.5 – 20	0 – 30
Initial voltage during start	%	0 – 85	5 – 50	30 – 70
Current limit function	x I_e	No	No	1.5 – 4 ^③
Switch for				
Inside delta connection ON/OFF		No	No	Yes
Signal relay				
Bypass signal		No ^④	No ^④	Yes
Fault signal		No	No	Yes
Rated operational voltage U_e	V	—	—	250
Rated thermal current I_{th}	A	—	—	5
Rated operational current I_e at AC 15 ($U_e=250V$)	A	—	—	1.5
Signal indication LED				
Ready to start/stand by	ON	Green	Green	Green
Ramping up/down		Yellow	Yellow (flashing)	No
Completed start ramp	T.O.R.	Yellow	Yellow	Green
General fault (internal)	F1	—	Red	Red
External fault (phase loss)	F2	—	—	Red

6

Size related data

Size	Type	A	Max. power loss at max I_e W	Max. SCR fuse rating (optional)	Bussman fuses	Power requirements of supply circuit VA
PSS03	TA25DU	2.2 – 3.1	—	16A	170M1359	2
PSS12	TA25DU	10 – 14	—	40A	170M1363	2
PSS25	TA25DU	18 – 25	—	50A	170M1364	5
PSS18/30	TA25DU	6 – 18	⑤	50A	170M1364	9
PSS30/52	TA25DU	10 – 30	⑤	80A	170M1366	9
PSS37/64	TA42DU	22 – 37	⑤	125A	170M1368	9
PSS44/76	TA75DU	29 – 44	⑤	160A	170M1369	9
PSS50/85	TA75DU	29 – 50	⑤	160A	170M1369	10
PSS60/105	TA75DU	29 – 60	⑤	200A	170M1370	10
PSS72/124	TA75DU	45 – 72	⑤	250A	170M1371	10
PSS85/147	TA110DU	65 – 85	⑤	315A	170M1372	36
PSS105/181	TA110DU	65 – 105	⑤	400A	170M3019	36
PSS142/245	TA200DU	100 – 142	⑤	450A	170M3020	36
PSS175/300	TA200DU	100 – 175	⑤	500A	170M3021	65
PSS250/430	TA450DU	130 – 250	⑤	700A	170M4017	65
PSS300/515	TA450DU	130 – 300	⑤	900A	170M5015	65

- ① When more than six starts per hour are required, contact your sales office.
 ② Above 40°C, up to max 60°C, reduce the rated current with 0.8% per °C.
 ③ Only if current transformer is connected (accessory).
 ④ The unit has built-in bypass contacts (AC-53b).
 ⑤ Total power loss: $P_{Ltot} = [3 \times I_e \times 1.0] + 50$ (W), reduced to 50W only when using by-pass.
 ⑥ 50% on and 50% off, 3.5 times rated current and 7 second starting time.



Technical data

Cross section of connection cables PSS03 – PSS25 and PSS18/30 – PSS300/515

Type PSS		PSS03 – PSS12	PSS25	PSS18/30-500 – PSS44/76-500	PSS50/85-500 – PSS72/124-500 & PSS18/30-690 – PSS72/124-690	PSS85/147-500 – PSS142/245-500 & PSS85/147-690 – PSS142/245-690	PSS175/300-500 – PSS300/515-500 & PSS175/300-690 – PSS300/515-690
Main circuit							
Connection clamp							
	Rigid solid/rigid stranded	1x AWG 12	AWG 6	AWG 4 - 8	AWG 1 - 8	—	—
	Rigid solid/rigid stranded	2x AWG 12	AWG 8	AWG 4 - 8	AWG 4 - 8	—	—
	Tightening torque (for guidance only) max. lb./in	4.3	17.5	23	40	—	—
Terminal lugs ^①							
6	Rigid solid / rigid stranded	1x —	—	—	—	#6 - 250 MCM	#4 - 400 MCM
	Rigid solid / rigid stranded	2x —	—	—	—	—	#4 - 500 MCM
	Tightening torque (for guidance only) max. lb./in	—	—	—	—	300	375
Connection bar							
	Width and thickness	mm —	—	—	—	17.5 x 5	20 x 5
	Hole diameter	mm —	—	—	—	8.5	10.2
	Tightening torque (for guidance only) max. lb./in	—	—	—	—	79	155
Supply and control circuit							
Connection clamp							
	Rigid solid/rigid stranded	1x AWG 12	AWG 12	AWG 12	AWG 12	AWG 12	AWG 12
	Rigid solid/rigid stranded	2x AWG 12	—	—	—	—	—
	Tightening torque (for guidance only) max. lb./in	4.3	4.3	4.3	4.3	4.3	4.3

^① See accessories on page 6.8.

Circuit diagrams

PSS03 – PSS25

Softstarters
Type PSS

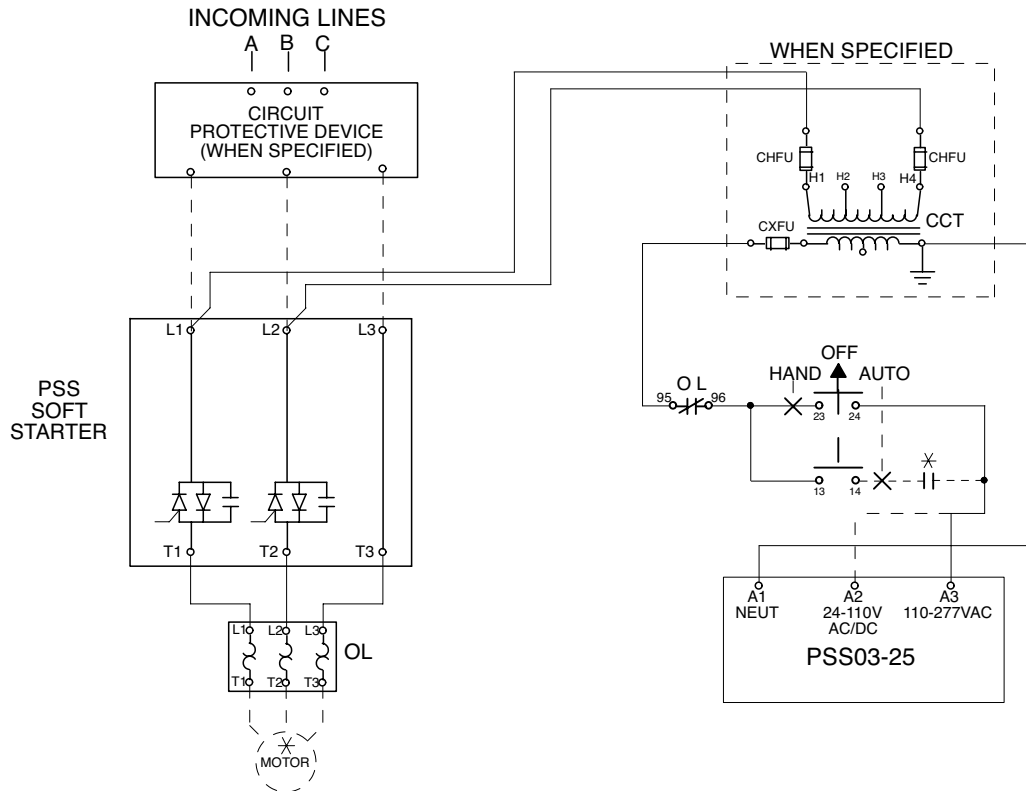

6

NOTES

1. ALL CONTROL WIRING TO BE 18GA. COLOR OF CONTROL WIRE SHALL BE PER VOLTAGE OF CONTACTOR COILS:
RED - ALL AC VOLTAGES
WHITE MAY BE USED ON THE GROUNDED SIDE OF THE AC CIRCUIT IF SPECIFIED.
BLUE - ALL DC VOLTAGES
2. ALL DEVICES ARE SHOWN DE-ENERGIZED.
3. DO NOT USE SELECTOR SWITCHES WITH AUTO-RESET OVERLOAD RELAYS.

LEGEND	
CCT	CONTROL CIRCUIT TRANSFORMER
CHFUs	CCT PRIMARY FUSE
CXFUs	CCT SECONDARY FUSE
B	BYPASS CONTACTOR
OL	OVERLOAD RELAY
o ₁₃	CONN POINT ON DEVICE WITH NUMBER
X	REMOTE DEVICE
∅	CONN POINT AT TERMINAL BLOCK

Circuit diagrams
Single-Phase ①②
PSS03 – PSS12

6

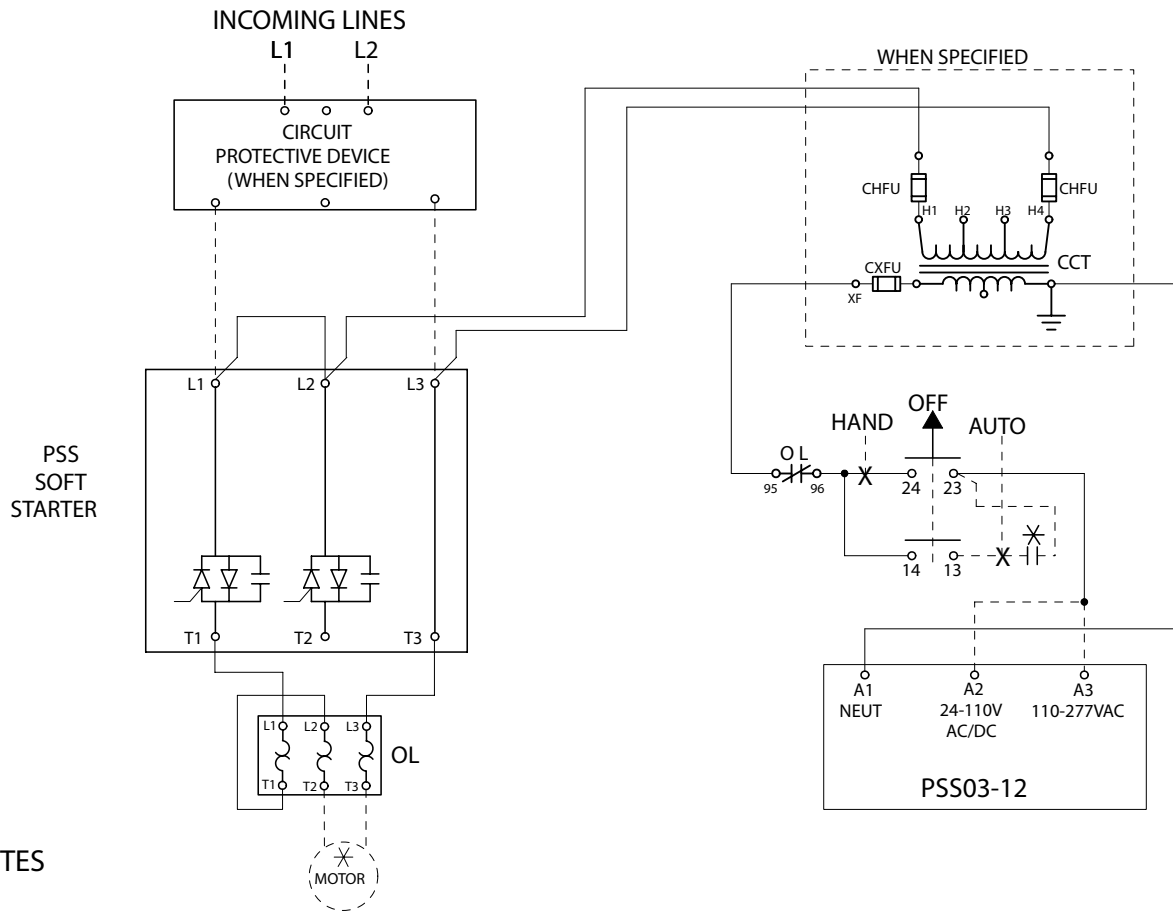

NOTES

1. ALL CONTROL WIRING TO BE 18GA. COLOR OF CONTROL WIRE SHALL BE PER VOLTAGE OF CONTACTOR COILS:
RED - ALL AC VOLTAGES
WHITE MAY BE USED ON THE GROUNDED SIDE OF THE AC CIRCUIT IF SPECIFIED.
BLUE - ALL DC VOLTAGES
2. ALL DEVICES ARE SHOWN DE-ENERGIZED.
3. DO NOT USE SELECTOR SWITCHES WITH AUTO-RESET OVERLOAD RELAYS.

LEGEND	
CCT	CONTROL CIRCUIT TRANSFORMER
CHF1	CCT PRIMARY FUSE
CXFU	CCT SECONDARY FUSE
OL	OVERLOAD RELAY
○ ₁₃	CONN POINT ON DEVICE WITH NUMBER
⊗	REMOTE DEVICE
∅	CONN POINT AT TERMINAL BLOCK

① Softstarter voltage rating must be the same as the network voltage.
② PSS25 cannot be used for single phase applications.

Circuit diagrams

PSS18/30 – PSS300/515, In-line motor configuration

Softstarters
Type PSS

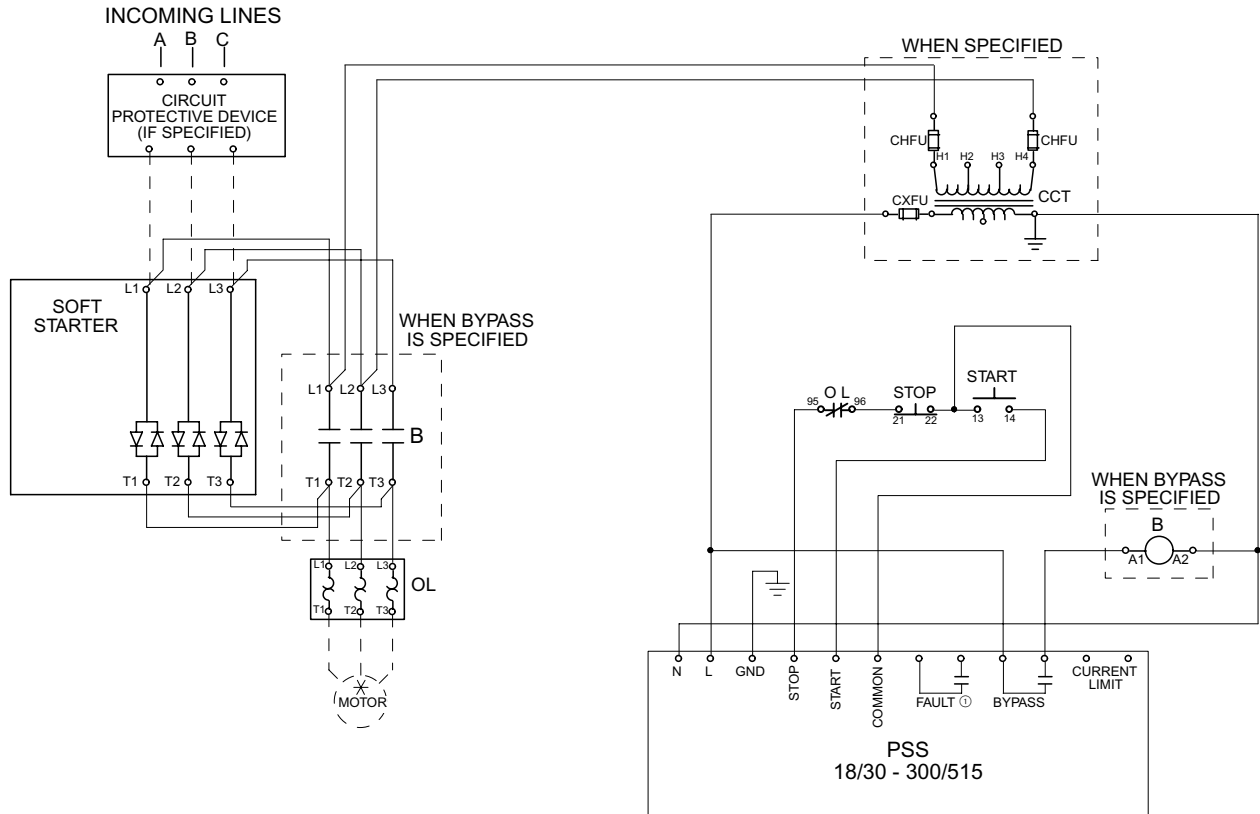

NOTES

- ALL CONTROL WIRING TO BE 18GA. COLOR OF CONTROL WIRE SHALL BE PER VOLTAGE OF CONTACTOR COILS:
RED - ALL AC VOLTAGES
WHITE MAY BE USED ON THE GROUNDED SIDE OF THE AC CIRCUIT IF SPECIFIED.
BLUE - ALL DC VOLTAGES
- ALL DEVICES ARE SHOWN DE-ENERGIZED.
- DO NOT USE SELECTOR SWITCHES WITH AUTO-RESET OVERLOAD RELAYS.

LEGEND	
CCT	CONTROL CIRCUIT TRANSFORMER
CHFU	CCT PRIMARY FUSE
CXFU	CCT SECONDARY FUSE
B	BYPASS CONTACTOR
OL	OVERLOAD RELAY
° ₁₃	CONN POINT ON DEVICE WITH NUMBER
*	REMOTE DEVICE
∅	CONN POINT AT TERMINAL BLOCK

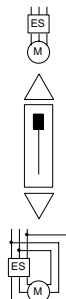

SET DIP SWITCH S1 AS SHOWN

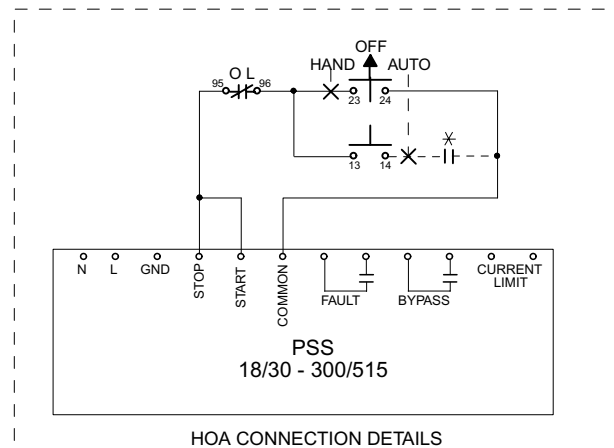

Circuit diagrams PSS18/30 – PSS300/515, Delta motor configuration

6

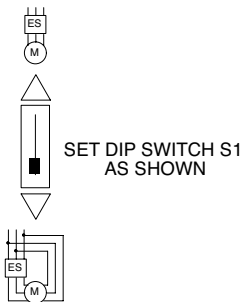
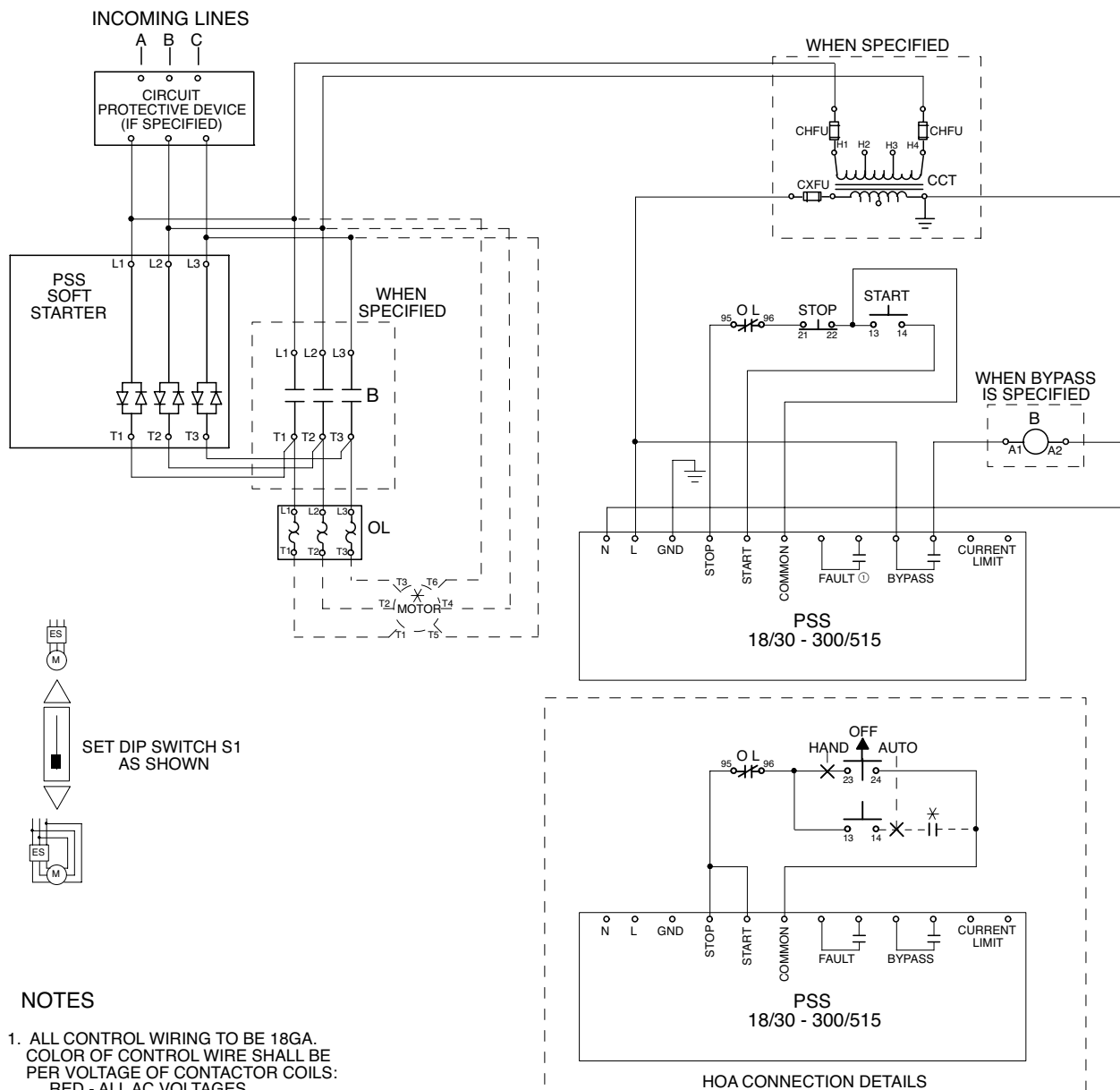

NOTES

- ALL CONTROL WIRING TO BE 18GA. COLOR OF CONTROL WIRE SHALL BE PER VOLTAGE OF CONTACTOR COILS:
RED - ALL AC VOLTAGES
WHITE MAY BE USED ON THE GROUNDED SIDE OF THE AC CIRCUIT IF SPECIFIED.
BLUE - ALL DC VOLTAGES
- ALL DEVICES ARE SHOWN DE-ENERGIZED.
- DO NOT USE SELECTOR SWITCHES WITH AUTO-RESET OVERLOAD RELAYS.

LEGEND	
CCT	CONTROL CIRCUIT TRANSFORMER
CHF1	CCT PRIMARY FUSE
CXFU	CCT SECONDARY FUSE
B	BYPASS CONTACTOR
OL	OVERLOAD RELAY
13	CONN POINT ON DEVICE WITH NUMBER
X	REMOTE DEVICE
Ø	CONN POINT AT TERMINAL BLOCK

MOTOR MARKINGS ARE AS DEFINED BY NEMA MG1-2.62 FOR 12 LEAD WYE START, DELTA RUN MOTOR CONNECTIONS. ALWAYS CONFIRM CORRECT LEAD MARKINGS WITH NAMEPLATE DIAGRAMS.

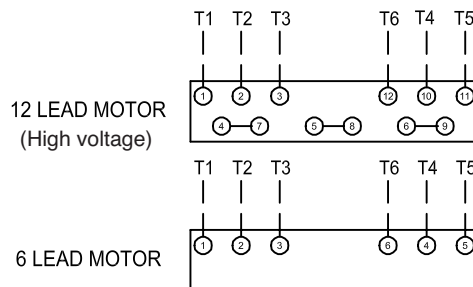

Circuit diagrams

PSS18/30 – PSS300/515, Delta motor configuration

Fault contactor

Softstarters
Type PSS

6

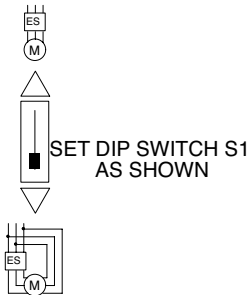
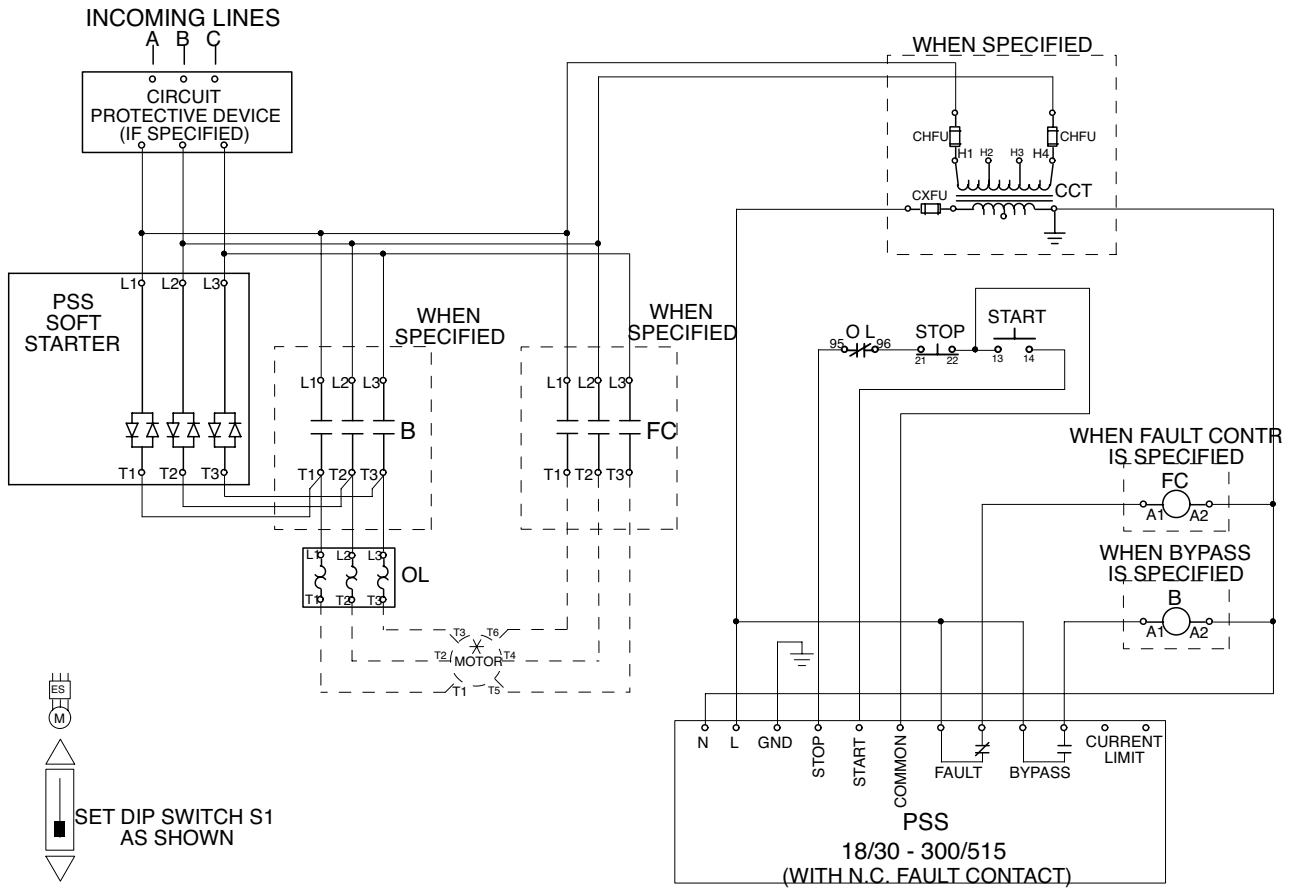

NOTES

- ALL CONTROL WIRING TO BE 18GA. COLOR OF CONTROL WIRE SHALL BE PER VOLTAGE OF CONTACTOR COILS:
RED - ALL AC VOLTAGES
WHITE MAY BE USED ON THE GROUNDED SIDE OF THE AC CIRCUIT IF SPECIFIED.
BLUE - ALL DC VOLTAGES
- ALL DEVICES ARE SHOWN DE-ENERGIZED.
- DO NOT USE SELECTOR SWITCHES WITH AUTO-RESET OVERLOAD RELAYS.

LEGEND	
CCT	CONTROL CIRCUIT TRANSFORMER
CHF1	CCT PRIMARY FUSE
CXFU	CCT SECONDARY FUSE
B	BYPASS CONTACTOR
OL	OVERLOAD RELAY
o ₁₃	CONN POINT ON DEVICE WITH NUMBER
X	REMOTE DEVICE
∅	CONN POINT AT TERMINAL BLOCK

MOTOR MARKINGS ARE AS DEFINED BY NEMA MG1-2.62 FOR 12 LEAD WYE START, DELTA RUN MOTOR CONNECTIONS. ALWAYS CONFIRM CORRECT LEAD MARKINGS WITH NAMEPLATE DIAGRAMS.

12 LEAD MOTOR
(High voltage)

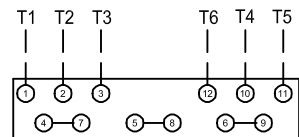

6 LEAD MOTOR

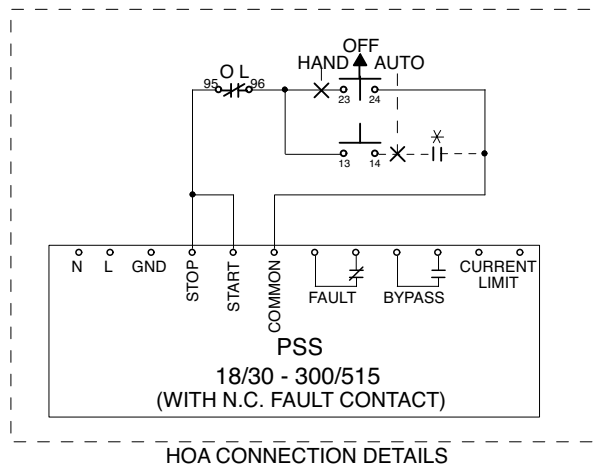
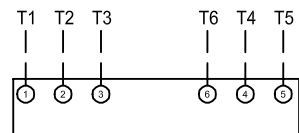

Approximate dimensions Open, PSS03 – PSS18-72

← 00.00 → Inches
00.00 → [Millimeters]

PSS03, PSS12

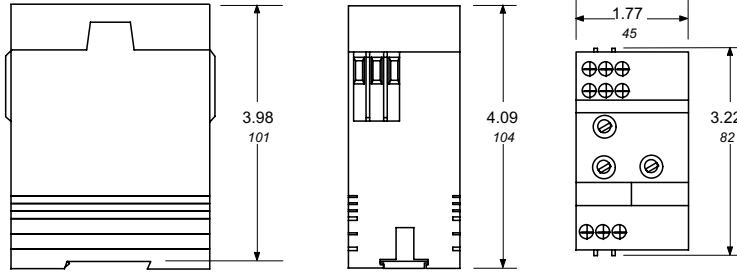

6

PSS25

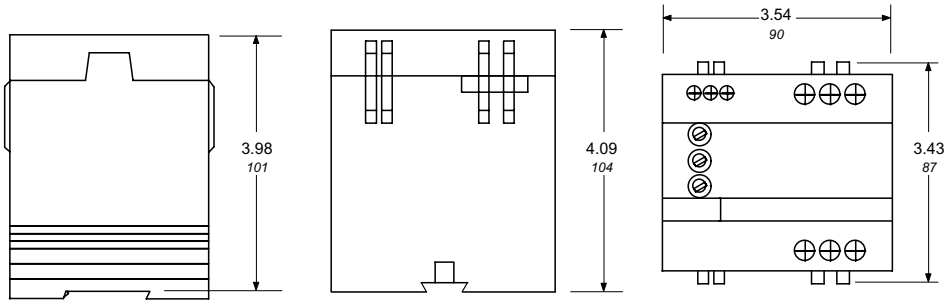

PSS18 to PSS44 (208V – 480V)

PSS18 to PSS72 (690V) PSS50 to PSS72 (208 – 480V)

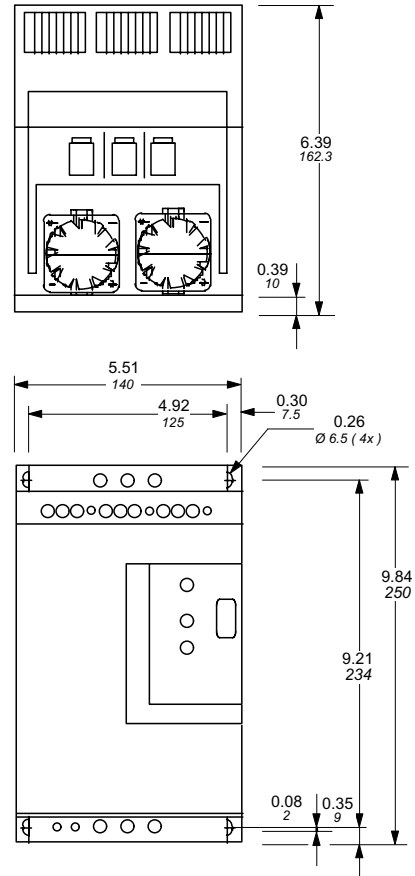
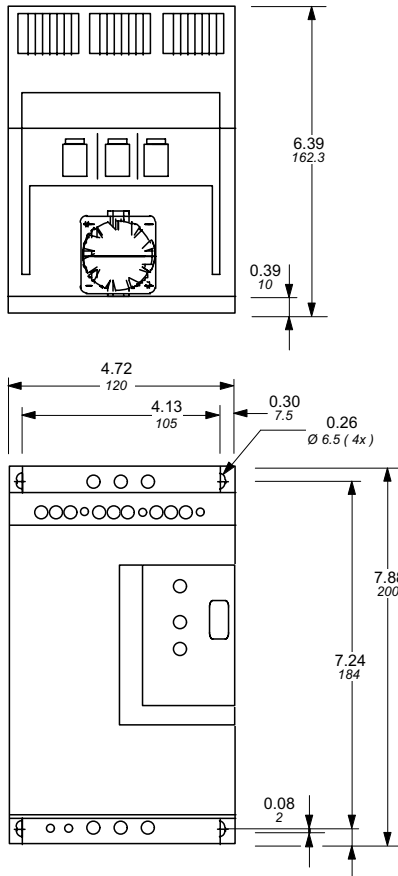

Approximate dimensions Open, PSS85 – PSS300

Softstarters
Type PSS

00.00 Inches
00.00 [Millimeters]

PSS85 to PSS142 (208V – 690V)

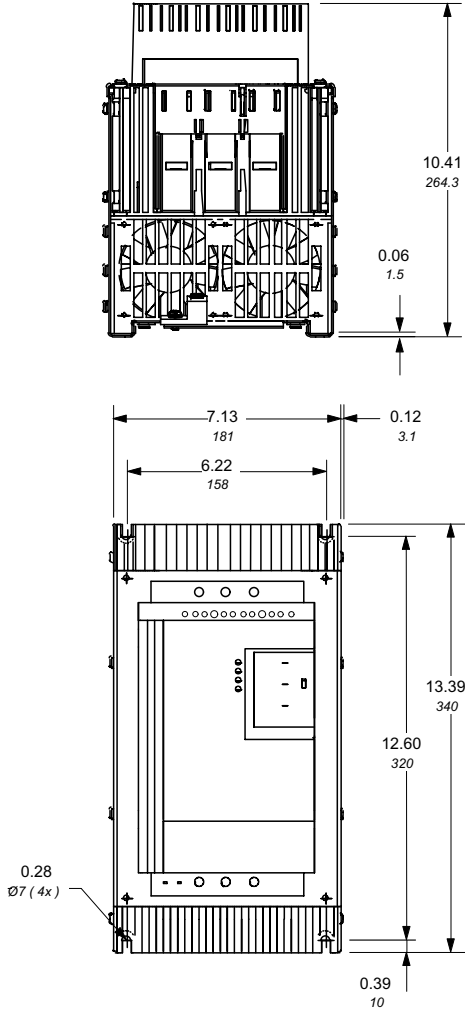

PSS175 to PSS300 (208V – 690V)

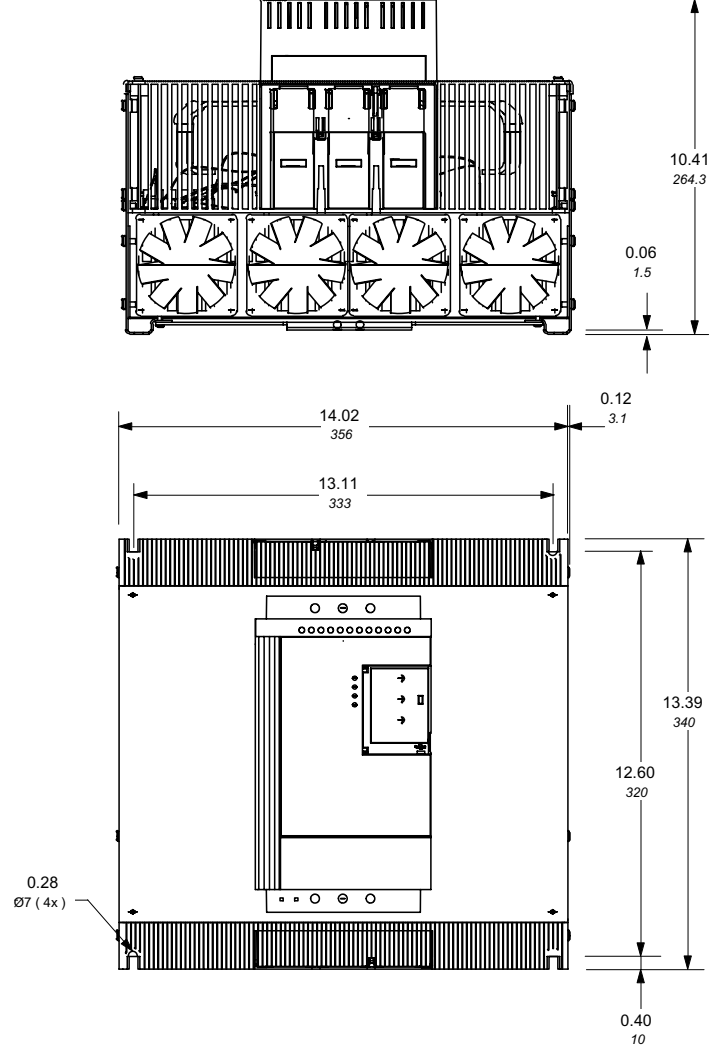

6

Approximate dimensions Enclosed

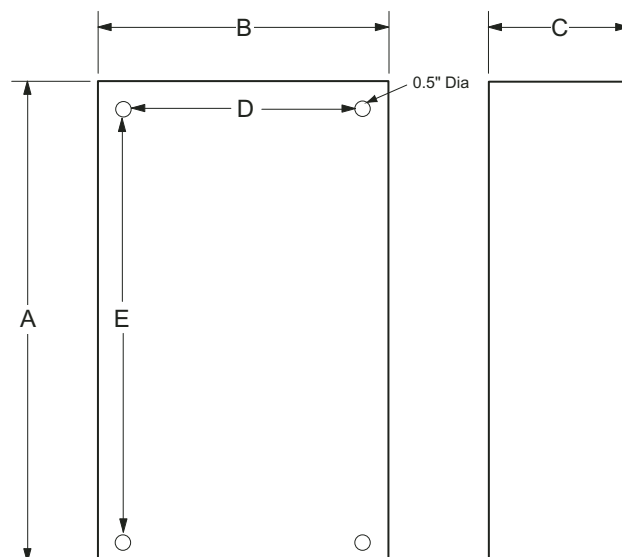

6

208V – 500V

Softstarter type	Softstarter combination	Dimensions In-line (in.)					Dimensions Inside delta (in.)				
		A	B	C	D	E	A	B	C	D	E
PSS18/30-500 thru PSS44/76-500	Softstarter only	20	20	12	18.50	18.50	20	20	12	18.50	18.50
	Softstarter with bypass	20	20	12	18.50	18.50	20	20	12	18.50	18.50
	Softstarter with fused disconnect ①	20	20	12	22.50	18.50	24	20	12	22.50	18.50
	Softstarter with circuit breaker ①	20	20	12	18.50	18.50	20	20	12	18.50	18.50
PSS50/85-500 thru PSS72/124-500	Softstarter only	20	20	12	18.50	18.50	20	20	12	18.50	18.50
	Softstarter with bypass	20	20	12	18.50	18.50	20	20	12	18.50	18.50
	Softstarter with fused disconnect ①	24	20	12	22.50	18.50	24	20	12	22.50	18.50
	Softstarter with circuit breaker ①	20	20	12	18.50	18.50	20	20	12	18.50	18.50
PSS85/147-500 thru PSS142/245-500	Softstarter only	24	24	16	22.50	22.50	24	24	16	22.50	22.50
	Softstarter with bypass	24	24	16	22.50	22.50	24	24	16	22.50	22.50
	Softstarter with fused disconnect ①	36	30	16	34.50	28.50	36	30	16	34.50	28.50
	Softstarter with circuit breaker ①	30	24	20	28.50	22.50	30	24	20	28.50	22.50
PSS175/300-500 thru PSS300/515-500	Softstarter only	60	36	12	58.50	34.50	60	36	12	58.50	34.50
	Softstarter with bypass	60	36	12	58.50	34.50	60	36	12	58.50	34.50
	Softstarter with fused disconnect ①	87	36	24	—	—	87	36	24	—	—
	Softstarter with circuit breaker ①	87	36	24	—	—	87	36	24	—	—

575V – 690V

PSS18/30-690 thru PSS72/124-690	Softstarter only	20	20	12	18.50	18.50	20	20	12	18.50	18.50
	Softstarter with bypass	20	20	12	18.50	18.50	20	20	12	18.50	18.50
	Softstarter with fused disconnect ①	24	20	12	22.50	18.50	24	20	12	22.50	18.50
	Softstarter with circuit breaker ①	20	20	12	18.50	18.50	20	20	12	18.50	18.50
PSS85/147-690 thru PSS142/245-690	Softstarter only	24	24	16	22.50	22.50	24	24	16	22.50	22.50
	Softstarter with bypass	24	24	16	22.50	22.50	24	24	16	22.50	22.50
	Softstarter with fused disconnect ①	36	30	16	34.50	28.50	36	30	16	34.50	28.50
	Softstarter with circuit breaker ①	30	24	20	28.50	22.50	30	24	20	28.50	22.50
PSS175/300-690 thru PSS300/575-690	Softstarter only	60	36	12	58.50	34.50	60	36	12	58.50	34.50
	Softstarter with bypass	60	36	12	58.50	34.50	60	36	12	58.50	34.50
	Softstarter with fused disconnect ①	87	36	24	—	—	87	36	24	—	—
	Softstarter with circuit breaker ①	87	36	24	—	—	87	36	24	—	—

① Dimensions remain the same if bypass contactor is added.

Approximate dimensions Mounting information



Minimum distance to wall / front

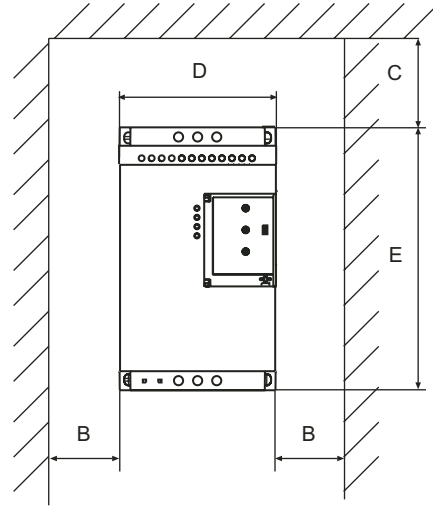
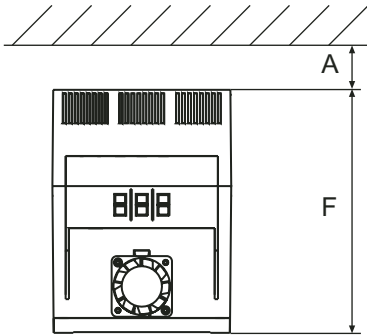

6

Approximate dimensions (in./mm)

Catalog number	Dimensions		
	D	E	F
PSS18/30-500 – 44/76-500	4.7/120	7.9/200	6.4/163
PSS50/85-500 – 72/124-500 PSS18/30-690 – 72/124-690	5.5/140	9.8/250	6.4/163
PSS85/147-500 – 142/245-500 PSS85/147-690 – 142/245-690	7.1/181	13.4/340	10.4/265
PSS175/300-500 – 300/515-500 PSS175/300-690 – 300/515-690	14/356	13.4/340	10.4/265

Minimum distance to wall / front (in./mm)

A = .79/20
 B = .39/10
 C = 3.9/100 – both top and bottom



Notes