

# BIW Controls

## Electrode Holders/Electrodes

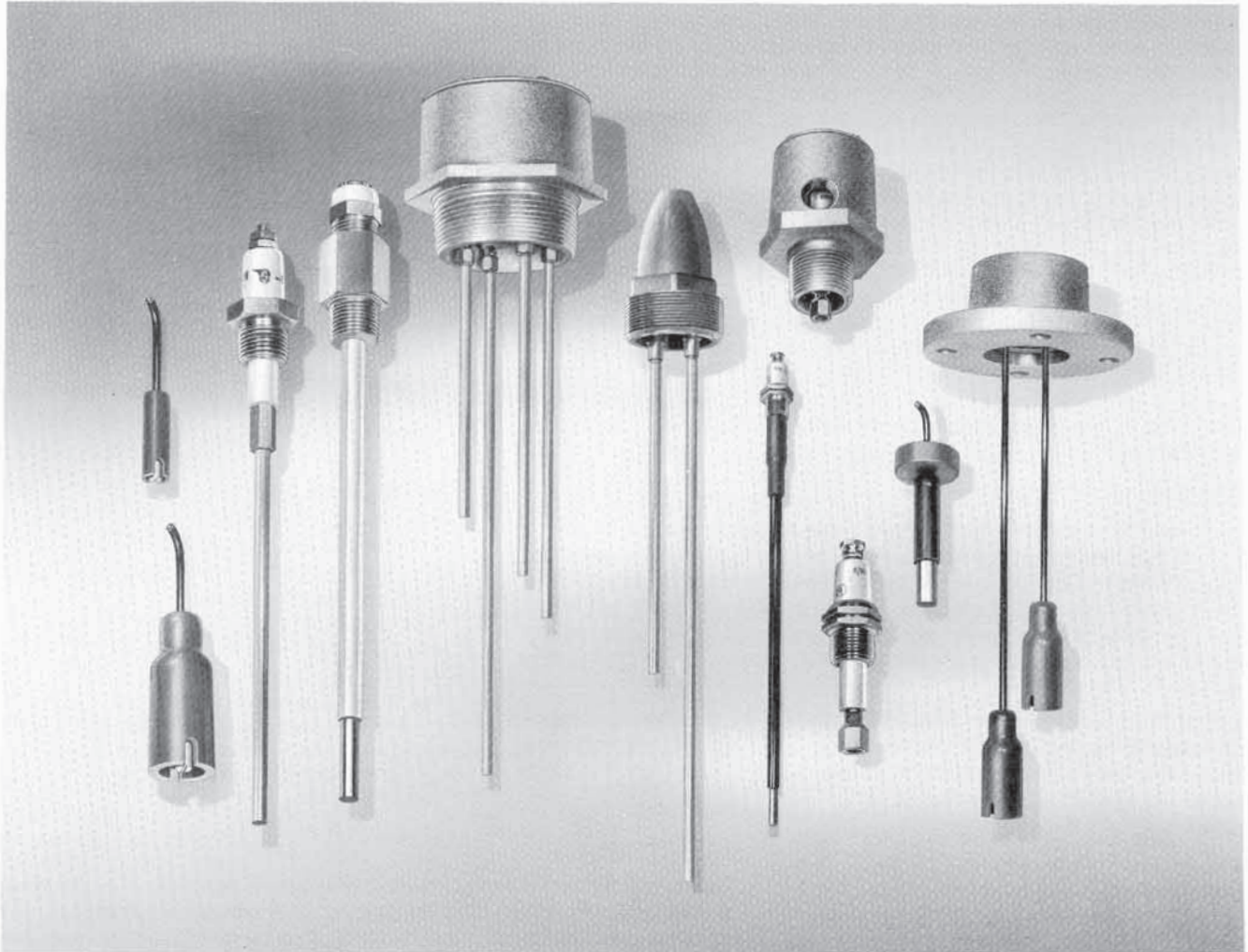

Since its introduction in 1933, the original BIW concept of utilizing the electrical conductivity of most liquids as a means of achieving liquid level control has won widespread acceptance as the most versatile and reliable system of its kind. In the BIW system of floatless liquid level control, electrodes or probes are suspended in the container to make contact with the liquid and thus complete a circuit which actuates a BIW relay. The relay contacts in turn are used for a wide range of applications such as controlling pumps and valves, or sounding alarms on level conditions.

Electrodes and holders should be selected according to the specific characteristics of the liquid involved, the lengths required to obtain the desired control of levels, and the physical nature of the container. Because of these factors, the BIW line of electrodes and holders presented in this section has been developed to provide a practical,

economical solution to almost every conceivable application and installation problem. When necessary, special equipment can also be supplied to meet specific needs.

Electrodes are normally used with a suitable holder and, wherever possible, should be suspended vertically downward from the top of the tank or other vessel containing the liquid. Also, electrodes are connected to the sensing circuit of a BIW relay. While this is a low energy circuit with inherently limited low current, the electrodes are terminals of a live electrical circuit and must be installed to prevent contact by unauthorized personnel.

**Whenever electrodes are installed in an explosive hazardous area, the BIW Series 5300 or 5510 relays with FM & CSA approved intrinsically safe sensing circuit must be used. See Catalog Section 5300.**

## SELECTING AND ORDERING ELECTRODE EQUIPMENT

The first step in selecting electrode equipment is to establish the overall general conditions for the specific application. The control functions desired will determine the BIW relays to be used, and also the number of electrodes required. Factors to be considered include: type of service such as indoor or outdoor installation; type of container for the liquid; nature, temperature and pressure of the liquid; any corrosive or hazardous condition existing; number and length of electrodes.

BIW electrode type of level control may be used on liquids that have sufficient conductivity to operate one of the BIW control relays, and they include potable water, steam condensate D.I. water, sewage, slurries acids, alkalies, salts, beer, blood, alcohols, milk, juices, water soluble oils, brine, plating solutions, baby foods, soups, and many others.

The BIW Unifloat<sup>®</sup> shown at the bottom of this page should be used for non-conducting liquids such as fuel and vegetable oils, gasolines and many organic chemicals that have specific resistance above 12 megohms-cm (Conductivity less than 0.1 micromho).

To assist in the selection of electrode equipment see the following pages where pictures and basic information is furnished for quick comparison of available types.

### ELECTRODE HOLDERS

In general BIW electrode holders have mounting provisions to mate with standard pipe fittings on the vessel, and the pressure and temperature ratings for the various types are shown on the specification pages. Most holders have water-tight protection for the conduit or cable entrance. Where possible, all electrodes should be grouped into a single holder and mounted on top of the tank with the electrodes extending vertically downward.

**Standard electrode holders are suitable for location in explosive hazardous areas, when BIW Series 5300 or 5510 relays with intrinsically safe sensing circuits are used to operate from the electrodes.**



#### BIW Unifloat<sup>®</sup>

- Ideal for non-conductive liquids such as gasoline, fuel oil, oily waste and organic chemicals.
- Just one float operates switches for up to 12 sensing levels.
- Simple level adjustment without disturbing tank connections.
- See Catalog Section 7014

### ELECTRODE HOLDER

For mechanical mounting and electrical isolation.



### ELECTRODE

Solid rod or wire suspension types are available.

### ORDERING INFORMATION

#### For Electrode Holders

Provide *complete* catalog number which will include number of electrode provisions and any special features.

#### For Solid Rod Electrodes

Provide *complete* catalog number which will include type, material and length.

#### For Wire Suspension Electrodes

Provide *complete* catalog number. In most cases the suspension wire and wire connector must be ordered as separate items.

### ELECTRODES

Solid rod electrodes are generally used where relatively short lengths of 6 feet or less are required. However, care should be exercised when specifying lengths over 3 feet to be certain there is head room to install them, and that liquid movement will not cause bare rods to deflect to touch one another, causing false relay operation.

Wire suspension electrodes are used for long lengths, and generally are more convenient to field set and adjust for operating lengths.





Electrodes subject to turbulence such as found in batching or slurry mixing applications should be strengthened with spacers, protected with a stilling tube, or Ruggedized Electrodes should be used. Gland electrode assemblies are recommended for installation in pipe lines or other applications where side thrust is to be encountered.

### CORROSION RESISTANCE





Ametek offers holders and electrodes in a variety of materials, and a standard arrangement is usually available to meet most situations. However, the rate of corrosion is affected by the concentration and temperature of the liquid as well as the presence of impurities or other compounds. Therefore, corrosion information in this catalog should be used as a general guide and the final choice should be based on previous experience and knowledge for the actual application conditions.

# B|W Controls

## Electrode Holders/Electrodes

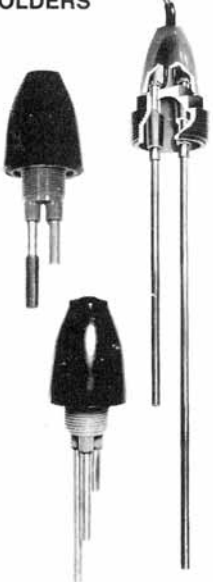
| <p>The following chart is provided to assist in selecting the proper Electrode Holder for your application. Refer to the Catalog Sections listed below for dimensions, list prices and additional engineering information.</p> <p>For information on electrodes see Catalog Section 6013 page 43 for wire suspension electrodes and page 44 for solid rod electrodes.</p> | <b>EXTERNAL PIPE THREADED ELECTRODE HOLDERS</b>   |               |                | <b>ELECTRODE PLUGS</b>  |                                | <b>FLANGED CAST IRON ELECTRODE HOLDERS</b>   |           |   | <b>FLANGED PVC ELECTRODE HOLDERS</b>  |           |             |         |        |         |               |       |          |       |         |                |                |   |
|---|---|---------------|----------------|---|--------------------------------|--|-----------|---|---|-----------|-------------|---------|--------|---------|---------------|-------|----------|-------|---------|----------------|----------------|---|
|   |    |               |                |  |                                |  |           |   |  |           |             |         |        |         |               |       |          |       |         |                |                |   |
| <b>MOUNTING ATTACHMENT TO VESSEL</b>  | 1" NPT  | 2" NPT        | 3" NPT         | 3/8" PTF  | 3" FLANGE                      | 4" FLANGE  | 6" FLANGE | 1" FLANGE   | 2" FLANGE   | 4" FLANGE | 5"x6" RECT. |         |        |         |               |       |          |       |         |                |                |   |
| <b>Number of Electrodes</b>   | 1   | 2-3           | 4-7            | 1   | 1-7                            | 1-13   | 1-13      | 1 Bare Or 2 Insulated                                       | 1-4   | 1-7       | 1-5         |         |        |         |               |       |          |       |         |                |                |   |
| <b>Temperature and Pressure of Liquid</b><br><small>*Specify #04141300 Electrode Plug</small>   | <table border="1"> <thead> <tr> <th>Mat'l.</th> <th>Max. Temp. °F.</th> <th>Max. Pressure</th> </tr> </thead> <tbody> <tr> <td rowspan="2">Brass</td> <td>200°F</td> <td>500 psi</td> </tr> <tr> <td>400°F*</td> <td>250 psi</td> </tr> <tr> <td rowspan="2">Cast Iron</td> <td>200°F</td> <td>500 psi</td> </tr> <tr> <td>400°F*</td> <td>250 psi</td> </tr> <tr> <td rowspan="2">316 Stainless</td> <td>200°F</td> <td>2000 psi</td> </tr> <tr> <td>450°F</td> <td>400 psi</td> </tr> </tbody> </table> | Mat'l.        | Max. Temp. °F. | Max. Pressure   | Brass                          | 200°F  | 500 psi   | 400°F*  | 250 psi   | Cast Iron | 200°F       | 500 psi | 400°F* | 250 psi | 316 Stainless | 200°F | 2000 psi | 450°F | 400 psi | Up to 2000 psi | 190°F<br>0 psi | 180°F<br>0 psi with Wire Suspended Electrodes<br>10 psi with Rod Electrodes |
| Mat'l.  | Max. Temp. °F.  | Max. Pressure |                |   |                                |  |           |   |   |           |             |         |        |         |               |       |          |       |         |                |                |   |
| Brass   | 200°F   | 500 psi       |                |   |                                |  |           |   |   |           |             |         |        |         |               |       |          |       |         |                |                |   |
|   | 400°F*  | 250 psi       |                |   |                                |  |           |   |   |           |             |         |        |         |               |       |          |       |         |                |                |   |
| Cast Iron   | 200°F   | 500 psi       |                |   |                                |  |           |   |   |           |             |         |        |         |               |       |          |       |         |                |                |   |
|   | 400°F*  | 250 psi       |                |   |                                |  |           |   |   |           |             |         |        |         |               |       |          |       |         |                |                |   |
| 316 Stainless   | 200°F   | 2000 psi      |                |   |                                |  |           |   |   |           |             |         |        |         |               |       |          |       |         |                |                |   |
|   | 450°F   | 400 psi       |                |   |                                |  |           |   |   |           |             |         |        |         |               |       |          |       |         |                |                |   |
| <b>CORROSION RESISTANCE</b>   | Available in Brass, Cast Iron or 316 Stainless  |               |                | 304SS   | Cast Iron                      |  |           | Unplasticized Polyvinyl Chloride (PVC)                      |   |           |             |         |        |         |               |       |          |       |         |                |                |   |
| <b>Solid Rod Electrode</b><br><small>(For lengths less than 6 ft.)</small>  | Available   |               |                | Available   | Not Available                  |  |           | Available   |   |           |             |         |        |         |               |       |          |       |         |                |                |   |
| <b>Wire Suspended Electrodes</b>  | Available   |               |                | Available   | Available                      |  |           | Available   |   |           |             |         |        |         |               |       |          |       |         |                |                |   |
| <b>Type of Service</b>  | Watertight, Outdoor Heavy Duty  |               |                | Industrial Duty   | Watertight, Outdoor Heavy Duty |  |           | Industrial Duty PVC for Corrosion Resistance and Watertight |   |           |             |         |        |         |               |       |          |       |         |                |                |   |
| <b>Electrode Height Adjustability</b>   | Solid Rod Electrodes Cut to Desired Length  |               |                |   | Adjustable                     |  |           | Adjustable with Wire Suspended Electrodes                   |   |           |             |         |        |         |               |       |          |       |         |                |                |   |
|   | Catalog Section 6012  |               |                | Catalog Section 6012  | Catalog Section 6012           |  |           | Catalog Section 6012  |   |           |             |         |        |         |               |       |          |       |         |                |                |   |

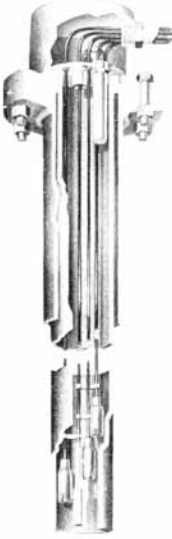

| MOLDED EXTERNAL<br>THREADED<br>ELECTRODE<br>HOLDERS                               |                            |                                    | CONDUIT<br>ELECTRODE<br>HOLDERS   |                        | CORD GRIP<br>ELECTRODE<br>HOLDERS   |         | ICE-FREE<br>ELECTRODE<br>ASSEMBLY   | GLAND<br>ELECTRODE<br>ASSEMBLIES  |                 | SPECIAL PURPOSE<br>ELECTRODE<br>ASSEMBLIES  |
|---|----------------------------|------------------------------------|---|------------------------|---|---------|---|---|-----------------|---|
|  |                            |                                    |  |                        |  |         |  |  |                 |  |
| 1-14<br>STRAIGHT<br>THREAD  | 1-14<br>STRAIGHT<br>THREAD | 2"<br>NPT                          | ½" NPT<br>or<br>½" PVC  | 1" NPT<br>or<br>1" PVC | ½" NPT  | ½" NPT  | 4"<br>FLANGE  | ¾"<br>NPT   | ½"<br>NPT       | VARIOUS   |
| 2   | 3                          | 2                                  | 1-4   | 1-8                    | 1   | 2       | 1-9   | 1   | 1               | 1   |
| Up To<br>200 psi<br>and<br>350°F  |                            | 100°F<br>250 psi<br>180°F<br>0 psi | 190°F<br>0 psi  |                        | 190°F<br>0 psi  |         | 190°F<br>0 psi  | 100 psi<br>@ 150°F<br>or<br>250 psi<br>@ 400°F                                      | 190°F<br>0 psi  | See<br>Catalog<br>Section   |
| Thermoplastic Holder<br>with 304 Stainless Studs                                  |                            |                                    | PVC or<br>Cast Iron   |                        | Aluminum  |         | Cast Iron   | Various   | 304<br>ss       |   |
| Available   |                            |                                    | Not Available   |                        |   | Special | Standard  |   |                 |   |
| Not<br>Available  | Avail-<br>able             | Available                          | Available   |                        | Standard  |         | Not<br>Available  |   |                 |   |
| Special<br>Applications   |                            |                                    | Watertight<br>Industrial Duty   |                        | Industrial<br>Duty  |         | Watertight, Outdoor<br>Heavy Duty   | Special<br>Applications   |                 |   |
| Solid Rod Electrodes<br>Cut to Desired Length                                     |                            |                                    | Adjustable  |                        | Adjustable  |         | Adjustable  | Fixed   | Adjust-<br>able |   |
| Catalog Section<br>6012   |                            |                                    | Catalog Section<br>6012   |                        | Catalog Section<br>6012   |         | Catalog Section<br>6012   | Catalog Section<br>6013   |                 |   |

# B|W Controls

## Electrode Holders/Electrodes

### CAST PRESSURE-TIGHT ELECTRODE HOLDERS WITH EXTERNAL PIPE THREAD

B/W pressure-tight electrode holders are designed especially for applications which require a positive, leak-proof assembly. Such installations include boiler feed and condensate return systems, hydropneumatic tanks, and various types of chemical processing equipment, etc.

Whenever possible, these holders should be mounted in a vertical position through the top of the tank with the electrodes extending downward to the desired operating levels.

For applications requiring flange mounting B/W offers companion flanges in 2", 3", or 4" sizes made of cast iron or 304 SS. See Catalog Section 7014.

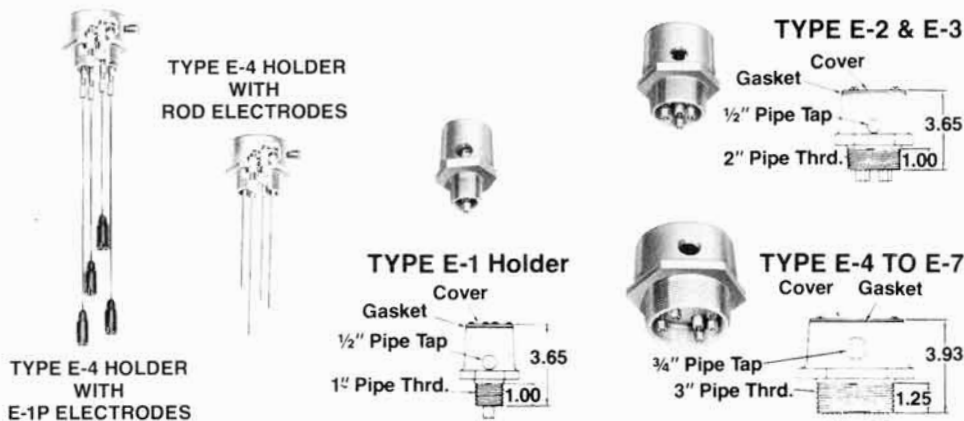

6012 — E1 — CI — EP1

CATALOG SECTION

| HOLDER MATERIAL |                     |
|-----------------|---------------------|
| CI              | Cast Iron           |
| BR              | Brass               |
| SS              | 316 Stainless Steel |

|    | No. of Electrodes | Mounting Thread | Shipping Weight |
|----|-------------------|-----------------|-----------------|
| E1 | 1                 | 1" Pipe         | 1.5 LB          |
| E2 | 2                 | 2" Pipe         | 3.0 LB          |
| E3 | 3                 | 2" Pipe         | 3.0 LB          |
| E4 | 4                 | 3" Pipe         | 5.0 LB          |
| E5 | 5                 | 3" Pipe         | 5.0 LB          |
| E6 | 6                 | 3" Pipe         | 6.0 LB          |
| E7 | 7                 | 3" Pipe         | 6.0 LB          |

NOTE — Price of electrode holder includes a standard electrode plug as indicated in the chart to the right.

| ELECTRODE PLUGS FOR CAST IRON & BRASS HOLDERS |   |
|---|---|
| EP1   | Furnished as standard equipment. Suitable for most applications. Up to 250 psi at 212°F (100°C). Up to 700°F (371°C) at 100 psi.                        |
| EP2   | Recommended for saturated steam applications. Up to 250 psi at 400°F (204°C). Up to 550°F (288°C) at 200 psi.   |
| EP3   | Recommended for low pressure applications that are subject to some vibration or shock. Also for long electrode rods.                                    |
| EP4   | Used only for non pressure applications and only for wire suspension electrodes where the standard plug and wire connector arrangement is not suitable. |
| X   | Holder furnished without electrode plugs but with the specified number of 3/8-18 Dryseal pipe thread holes for the plugs.                               |

#### CROSS REFERENCE TO OLD BIW PART NUMBERS

| HOLDER TYPE | NUMBER OF ELECTRODES | MATERIALS AND PART NUMBERS |           |               |
|-------------|----------------------|----------------------------|-----------|---------------|
|             |                      | BRASS                      | CASTIRON  | 316 STAINLESS |
| E-1         | 1                    | 12-048000                  | 12-048100 | 12-048200     |
| E-2         | 2                    | 12-048400                  | 12-048500 | 12-048600     |
| E-3         | 3                    | 12-048800                  | 12-048900 | 12-049000     |
| E-4         | 4                    | 12-049200                  | 12-049300 | 12-049400     |
| E-5         | 5                    | 12-049600                  | 12-049700 | 12-049800     |
| E-6         | 6                    | 12-050000                  | 12-050100 | 12-050200     |
| E-7         | 7                    | 12-050400                  | 12-050500 | 12-050600     |

| ELECTRODE PLUGS FOR 316 SS HOLDERS |   |
|------------------------------------|---|
| EP2                                | Furnished as standard equipment. Suitable for many corrosive applications, and for saturated steam up to 400 psi and 445°F (230°C). |
| EP3                                | Recommended for low pressure applications that are subject to some vibration or shock. Also for long electrode rods.                |
| X                                  | Holder furnished without electrode plugs but with the specified number of 3/8-18 Dryseal pipe thread holes for the plugs.           |

Ametek offers a wide selection of BIW electrode plugs for mounting electrodes in tanks and vessels. They are designed to meet a variety of environmental conditions to provide a strong mechanical mounting and to insulate the electrode from the tank structure; they also have a secure method to make the electrode lead wire connection to the BIW control relay. Details of a typical pressure tight electrode plug are shown in the diagram at the right. The central rod is sealed to the inside of the ceramic insulator glass, and the stainless steel bushing is sealed to the outside of the insulator with copper and/or Teflon® gaskets.

Electrode plugs are included in the Type E electrode holders. Also, these plugs are often used on OEM applications to provide reliable and inexpensive individual mounting of electrodes in special situations.

Other types of electrode plug and electrode assemblies are described in this Section. Should none of our standard items be suitable, special electrodes can be made to order to meet specific operating and/or installation conditions.

## ELECTRODE PLUGS

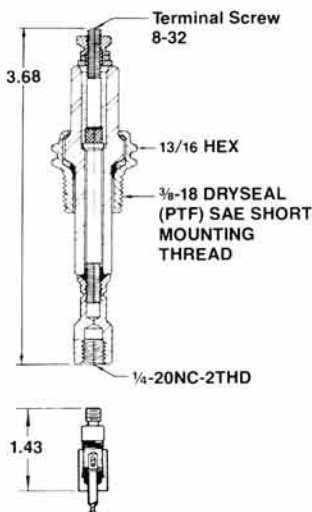

**WIRE CONNECTOR**  
One required with each wire suspension electrode.

### SOLID ROD ELECTRODES

Type A rod is used for short electrodes and is available in a variety of corrosion-resisting materials.

### WIRE SUSPENSION ELECTRODES

These electrodes are used for long lengths and where space prevents use of rod electrodes.

6012 — EP2  
CATALOG SECTION

These plugs can be installed in Type E Holders.

|     | OLD PART NUMBER | MOUNTING THREAD                            | CONSTRUCTION MATERIALS                                   | PRESSURE/TEMPERATURE RATINGS  |
|-----|-----------------|--|--|---|
| EP1 | 04-126400       | 3/8-18 Dryseal (PTF) SAE Short Pipe Thread | Shell-303SS<br>Insulator-Ceramic<br>Seal-Glass & Copper  | 2000 psi Up to 200°F (93°C)<br>700°F (371°C) Up to 100 psi                                  |
| EP2 | 04-141300       | 3/8-18 Dryseal (PTF) SAE Short Pipe Thread | Shell-303SS<br>Insulator-Ceramic<br>Seal-Glass & Teflon® | 2000 psi Up to 200°F (93°C)<br>550°F (288°C) Up to 200 psi<br>Saturated Steam Up to 450 psi |
| EP3 | 04-149600       | 3/8-18 Dryseal (PTF) SAE Short Pipe Thread | Shell-303SS<br>Insulator-Teflon®<br>Seal-Teflon®         | 500 psi Up to 270°F (132°C)<br>300°F (149°C) Up to 250 psi<br>Saturated Steam Up to 125 psi |
| EP4 | 12-066400       | 3/8-18 NPT Pipe Thread                     | Shell-Aluminum<br>Cord Grip with<br>Neoprene Packing     | For Nonpressure Use<br>Up to 190°F (88°C)<br>(Only for wire suspension electrodes)          |

6012 — EP5  
CATALOG SECTION

This plug is for separate mounting only.

|     | OLD PART NUMBER | MOUNTING THREAD             | CONSTRUCTION MATERIALS                                  | PRESSURE/TEMPERATURE RATINGS                               |
|-----|-----------------|-----------------------------|---|--|
| EP5 | 04-134900       | 5/8-24 NEF-3 Machine Thread | Shell-303SS<br>Insulator-Ceramic<br>Seal-Glass & Copper | 2000 psi Up to 200°F (93°C)<br>700°F (371°C) Up to 100 psi |

| ELECTRODE PLUG COVER |              |   |
|----------------------|--------------|---|
| Catalog Number       | Old Part No. | Designed to insulate and protect the electrode lead connection. Made of neoprene and fits all standard plugs. |
| 6012-PC              | 04-129000    |   |



# B|W Controls

## Electrode Holders/Electrodes

### FLANGED CAST IRON ELECTRODE HOLDERS

These flanged holders are for use with B|W wire suspension electrodes in non-pressure applications such as elevated tanks, water reservoirs, underground storage tanks, sewage wet wells and other installations requiring relatively long electrode lengths. They are of rugged construction made of cast iron with baked aluminum paint finish to be very durable for many years of outdoor exposure. Available in 3", 4" and 6" sizes which fit the 125 Lb. Cl and 150 Lb. Steel mounting flange specifications.

These holders have a removable inner plate provided with a grommet for each wire suspension electrode. The grommets are sized to give a snug vapor tight fit with B|W Type SW electrode suspension wire, and the electrodes are secured by means of a simple overhand knot in the suspension wire as shown in the picture below. The mounting plate with electrodes attached can be easily removed through the top of the electrode holder to facilitate cleaning and adjustment of the electrodes when required.



**TYPE E-55-3 HOLDER**  
3 inch Cast Iron 125 lb. Mounting With Aluminum Paint Finish For 1 to 7 Wire Suspension Electrodes.

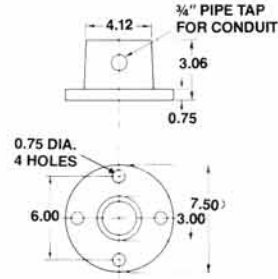

**TYPE E-55-6 HOLDER**  
6 inch Cast Iron 125 lb. Mounting With Aluminum Paint Finish For 1 to 13 Wire Suspension Electrodes.

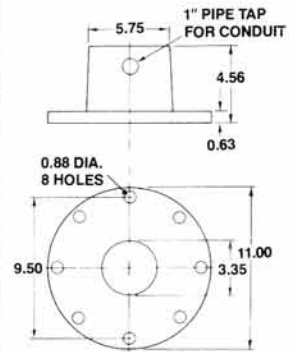

**TYPE E-55-4 HOLDER**  
4 inch Cast Iron 125 lb. Mounting With Aluminum Paint Finish For 1 to 13 Wire Suspension Electrodes.

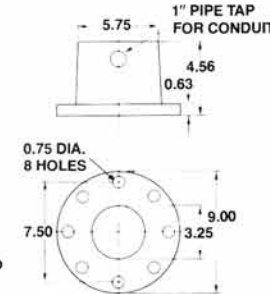

6012  
CATALOG SECTION

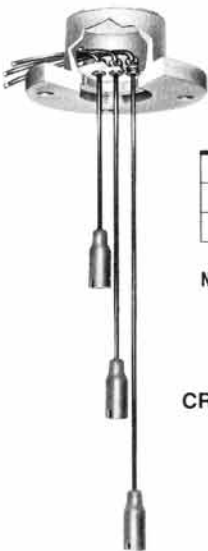

E553

|      | Mounting Provision | Number Of Electrodes | Shipping Weight |
|------|--------------------|----------------------|-----------------|
| E553 | 3 in. Flange       | 1-7                  | 14 lb.          |
| E554 | 4 in. Flange       | 1-13                 | 24 lb.          |
| E556 | 6 in. Flange       | 1-13                 | 30 lb.          |

**NOTE:** These holders are not available for use with solid rod electrodes. For applications requiring rod electrodes with flange mounting, use a Type E holder and a separate threaded mounting flange.

**CROSS REFERENCE TO OLD BIW PART NUMBERS**

| Holder Type | Old Part Number |
|-------------|-----------------|
| E-55-3      | 12-054400       |
| E-55-4      | 12-056400       |
| E-55-6      | 12-056700       |

5E

These electrode holders are for non pressure applications only

|     | Number Of Openings Provided For Wire Suspension Electrodes |
|-----|--|
| 1E  | 1  |
| 2E  | 2  |
| 3E  | 3  |
| 4E  | 4  |
| 5E  | 5  |
| 6E  | 6  |
| 7E  | 7  |
| 8E  | 8  |
| 9E  | 9  |
| 10E | 10   |
| 11E | 11   |
| 12E | 12   |
| 13E | 13   |

**NOTE:** The required wire suspension electrodes must be ordered as separate items.

These versatile corrosion resistant electrode holders are made of unplasticized PVC for use on industrial and chemical applications such as acid storage tanks, plating tanks and liquid waste treatment systems. They are suitable for ambient temperatures up to 180°F (82°C). They include a watertight PVC cover or a junction box. Types are available for mounting on standard 1", 2", 3" or 4" flanges. The Type FR56 is intended for mounting on the corner of an open flanged rim tank, and only requires minimum space in the tank.

Models are available for use with either solid rod or wire suspension electrodes which must be ordered as separate items for field assembly at time of installation.

Solid rod electrodes extend thru the bottom of the holder and are tightened against a shoulder which provides a vapor tight seal for up to 10 psi. Rods should be insulated for lengths greater than 30 in.

Wire suspension electrodes are recommended for lengths over 6 feet. The BIW Type SW suspension wire is brought into the holder through a clearance hole and is secured by a knot as illustrated below. The Type 13-064700 electrodes are available in the same selection of materials as the solid rods and must be used for corrosive liquids.

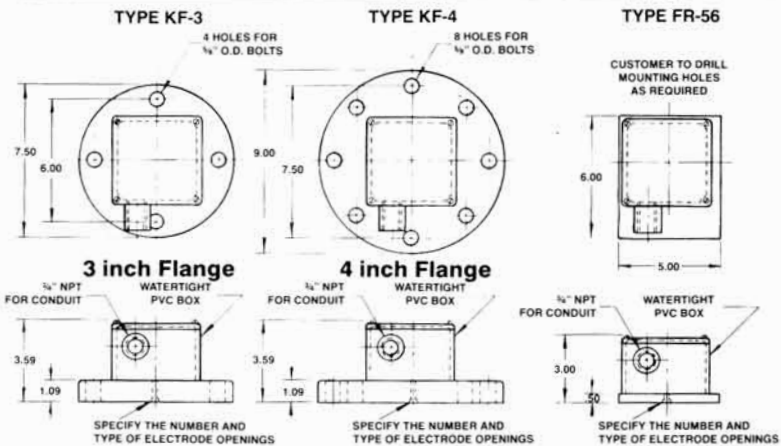
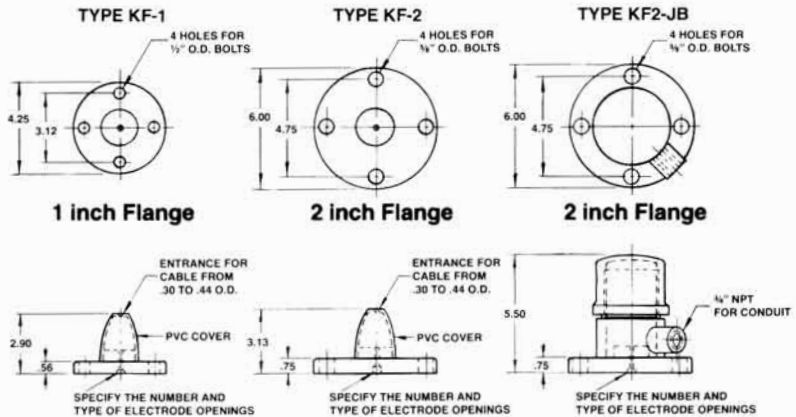

6012  
CATALOG SECTION



|       | ELECTRODE OPENINGS                   |                 |
|-------|--------------------------------------|-----------------|
|       | Specify Number of Openings Required. |                 |
|       | MAX. NO. OF ELECTRODES               | SHIPPING WEIGHT |
| KF1   | *1 or 2                              | 1.0 LB.         |
| KF2   | 4                                    | 2.0 LB.         |
| KF2Jb | 4                                    | 2.5 LB.         |
| KF3   | 7                                    | 3.0 LB.         |
| KF4   | 7                                    | 4.0 LB.         |
| FR56  | 5                                    | 1.5 LB.         |

\*One bare rod or wire suspension electrode, or two insulated rods.

| Type of Electrode To Be Used                                  |
|---|
| RC<br>Type C Solid Rod<br>For Type KF Holders                 |
| RD<br>Type D Solid Rod<br>For Type FR Holders                 |
| WS<br>Wire Suspension Electrodes<br>For Type KF or FR Holders |

NOTE: The required electrodes must be ordered as separate items for field assembly to holder.

CROSS REFERENCE TO OLD PART NUMBERS

| HOLDER TYPE | Bare Rods | Insulated Rods | Wire Suspension |
|-------------|-----------|----------------|-----------------|
| KF1         | 12-066300 | 12-066100      | 12-083400       |
| KF2         | 12-063800 | 12-062400      | 12-077800       |
| KF2Jb       | 12-083500 | 12-082900      | 12-083100       |
| KF3         | 12-065200 | 12-070700      | 12-077300       |
| KF4         | 12-071100 | 12-071500      | 12-081700       |
| FR56        | 12-080500 | 12-080300      | 12-083300       |

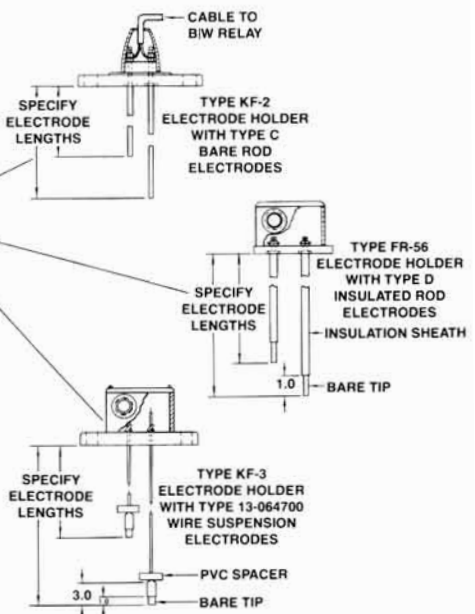



# B|W Controls

## Electrode Holders/Electrodes

### MOLDED ELECTRODE HOLDERS

**Type CE-2 & CE-3 Holders** — These small holders are primarily for use in original equipment applications where available space is limited and where desired level control can be obtained with two or three short solid rod electrodes. They are furnished with a flexible PVC water-tight cover to protect lead wire junctions.

A choice of two thermoplastic materials is available with ratings as shown below. Pressure seal is accomplished with a Buna N gasket included with each holder. They have 303SS studs with 6-32 male thread for electrode connections.



Type AE-2 with rod electrodes

| HOLDER MATERIAL | MAXIMUM RATINGS                                 |
|-----------------|---|
| Butyrate        | 200 psi @ 100°F (38°C)<br>160°F (71°C) @ 0 psi  |
| Nylon           | 200 psi @ 200°F (93°C)<br>350°F (177°C) @ 0 psi |



Type CE-2 Holder For 2 Rod Electrodes 1"-14 Straight Machine Thread



Type CE-3 Holder For 3 Rod Electrodes 1"-14 Straight Machine Thread

CATALOG NUMBER 6012 — CE2B

| Holder Material | Old Part Number |
|-----------------|-----------------|
| CE2B Butyrate   | 12-053600       |
| CE2N Nylon      | 12-082500       |

CATALOG NUMBER 6012 — CE3B

| Holder Material | Old Part Number |
|-----------------|-----------------|
| CE3B Butyrate   | 12-073500       |
| CE3N Nylon      | 12-082700       |

NOTE: The required Type 6B rod electrodes must be ordered as separate items. Maximum recommended bare rod length is 12 inches. Not available for wire suspension electrodes.

**Type AE-2 Holders** — Molded of ABS corrosion-resistant thermoplastic material, these holders are ideal for use in applications involving control of many corrosive liquids. Designed to permit the use of either two solid rod or two wire suspension electrodes, they are supplied with flexible PVC water-tight covers to protect the lead wire junctions.

They have 303SS couplings with 1/4-20 female thread for electrode connections.



### TYPE AE-2 HOLDER

For 2 Rod or Wire Suspension Electrodes 2" NPT Pipe Thread Mounting

Catalog No. 6012-AE2  
Old Part No. 12-034500

| MAXIMUM RATINGS                                |
|--|
| 250 psi @ 100°F (38°C)<br>180°F (82°C) @ 0 psi |

NOTE: The required electrodes must be ordered as separate items, see Catalog Section 6013 for information.  
Rod Electrodes — Type A rods are used.  
Wire Suspension Electrodes — A wire connector is required for each wire suspension electrode.

### CONDUIT ELECTRODE HOLDERS



Designed for use with B|W wire suspension electrodes, these versatile low-cost holders are recommended for underground drainage sumps, septic dosing tanks, open sumps and similar applications. Available in cadmium plated cast iron for general purpose applications, or rigid polyvinyl chloride for corrosive situations.

These holders are mounted by attaching to a length of standard conduit extending over the liquid being controlled. They have grommets for each wire suspension electrode, and come in two sizes to accommodate up to eight electrodes.

CATALOG NUMBER 6012 — C4I

|     | No. of Electrodes | Holder Material | Conduit Size | Connection Type | Old Part Number |
|-----|-------------------|-----------------|--------------|-----------------|-----------------|
| C4I | 1-4               | Cast Iron       | 1/2" NPT     | Threaded        | 12-056900       |
| C4P | 1-4               | PVC             | 1/2" PVC     | Cement          | 12-065400       |
| C8I | 1-8               | Cast Iron       | 1" NPT       | Threaded        | 12-081800       |
| C8P | 1-8               | PVC             | 1" PVC       | Cement          | 12-081900       |

NOTE: The required wire suspension electrodes must be ordered as separate items.

### CORD GRIP ELECTRODE HOLDERS



Type CG1 with E-IP Electrode



Type CG2 with E-IS Electrodes

B|W cord grip electrode holders provide a simple, low-cost means of sealing lead wire openings against leakage of gases and liquids in non-pressure applications requiring use of wire suspension electrodes. These include submersible pump installations with low level cutoff control, underground water storage tanks, covered sumps, and sewage pumping stations.

Made of aluminum machined for 1/2" pipe thread mounting, they are furnished with compressible Neoprene packing to support either one or two wire suspension electrodes.

CATALOG NUMBER 6012 — CG1

|     | No. of Electrodes | Holder Material | Mounting Thread | Old Part Number |
|-----|-------------------|-----------------|-----------------|-----------------|
| CG1 | 1                 | Aluminum        | 1/2" NPT        | 12-055900       |
| CG2 | 2                 | Aluminum        | 1/2" NPT        | 12-056000       |

NOTE: The required wire suspension electrodes must be ordered as separate items.

## STANDARD ASSEMBLY

BIW ice-free electrode units are designed to provide positive, reliable pump control in areas where severe winter temperatures cause icing conditions which would normally interfere with or prevent proper pump operation.

The assembly consists of a Type 6012-E554 cast iron flanged electrode holder threaded onto a 3" steel pipe and details are illustrated at the right. The thermostat is factory set to close at 32°F (0°C), and the heater will keep the water inside the 3" pipe free of ice even when heavy ice forms on the surface of the water surrounding the ice-free electrode assembly. The 4" pipe nipple with companion flange is provided to mount the unit. The nipple must be attached vertically to the tank top, and the rest of the assembly is then lowered and bolted into place.

When designing the control system, provisions must be made to cut-off the power to the immersion heater whenever the water level falls below the lowest electrode because the heater will burn out if it is energized when exposed to air.

A single pump, pump up system requires a B/W Type 1500-G relay with the NC contact controlling the pump, and the NO contact providing cut-off for the heater. See Catalog Sections 8040 and 8044 for information on standard and custom control panels.

## TYPE IFW

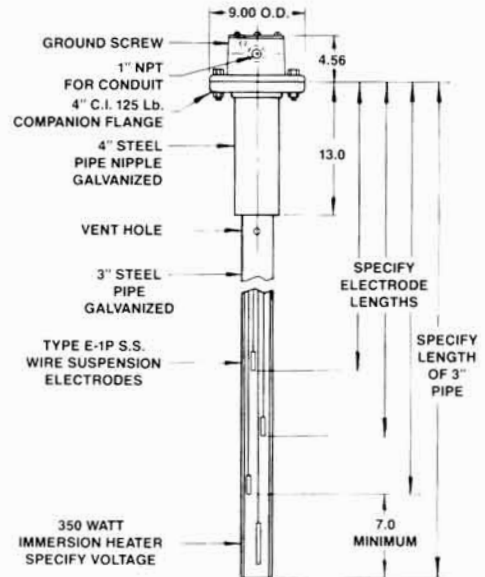

**6012-IFW-4-L1** — **8** — **X**

**CATALOG SECTION**

| LINE VOLTAGE |                   |
|--------------|-------------------|
| L1           | 115 Volt-50/60 Hz |
| L2           | 230 Volt-50/60 Hz |

E-IF Old Part Number 12-041500  
Other voltages not available.

The type IFW is for non-pressure applications. Contact factory if a pressure-tight ice-free unit is required.

| SPECIFY QUANTITY AND LENGTH OF ELECTRODES        |                  |
|--|------------------|
| Type W2 E-1P 304SS<br>Wire Suspension Electrodes | 1 to 9 (Maximum) |

| SPECIFY LENGTH OF 3 INCH PIPE — FEET |  |
|--------------------------------------|--|
| 2 ft. (Minimum) to 6 ft.             |  |
| 7 ft. to 21 ft.                      |  |
| Over 21 ft.                          |  |

If electrode lengths are not specified, they will be factory set at maximum length based on the 3" pipe length.

| OPTIONAL FEATURES |   |
|-------------------|---|
| X                 | None  |
| LP                | Omit 3 inch Pipe<br>Old Part No. 01-226000                            |
| LN                | Omit 4 inch Pipe Nipple<br>Old Part No. 09-155600                     |
| LF                | Omit 4 inch Companion Flange, Bolts, & Nuts<br>Old Part No. 04-105400 |

NOTE — if more than one item is to be omitted, include the symbol for each item deducted.  
Example — LP-LN-LF

## TYPE IFR

Some applications such as cooling tower basins require short electrode lengths, and as shown at the left, the Type IFR will mount directly on a tank top, or on a bracket inside the basin.

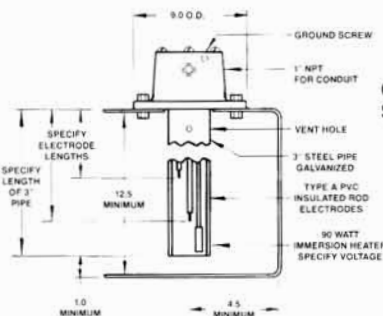

**6012-IFR-3-L1** — **26**

**CATALOG SECTION**

| LINE VOLTAGE |                   |
|--------------|-------------------|
| L1           | 115 Volt-50/60 Hz |

E-IF Old Part Number 12-074400

| SPECIFY QUANTITY AND LENGTH OF ELECTRODES     |                  |
|---|------------------|
| Type A 316SS PVC Ins.<br>Solid Rod Electrodes | 1 to 4 (Maximum) |

| SPECIFY LENGTH OF 3 INCH PIPE-INCHES  |  |
|---------------------------------------|--|
| 12 inch minimum<br>to 48 inch maximum |  |

## SHALLOW TANK ASSEMBLY

These assemblies have electrode plug and stainless PVC insulated solid rod electrodes. The 115 VAC heater is designed for operation in air and low level cut-off provision should not be provided.

- Other voltages not available.
- Order cannot be processed without length of each electrode and length of the 3 inch pipe.
- The Type IFR is for non-pressure applications. Contact factory if a pressure-tight ice-free unit is required.

### WIRE SUSPENSION ELECTRODES

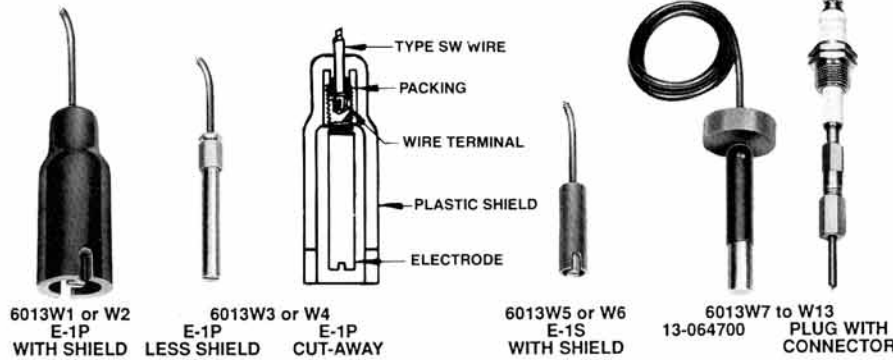

**WIRE CONNECTOR:** This adapter is necessary to attach the Type SW suspension wire to the 1/4-20 female electrode holder connections. One is required for each wire suspension electrode used with electrode plugs, and Type E and Type AE-2 holders.

**CATALOG NUMBER**  
6013—C—BR



| Material                    |    |
|-----------------------------|----|
| Brass<br>Old No. 12-038400  | BR |
| 303 SS<br>Old No. 12-043800 | SS |

Wire suspension electrodes are designed for use in applications requiring long lengths, or where limited head room prevents installation of solid rod electrodes. They can be used with all holders except Type CE-2 & 3. Electrode Types E-1P and E-1S are for use in water and non-corrosive liquids. Type 13-064700 is designed for corrosive liquids and is available with a variety of rod materials. Types E-1P and E-1S electrodes with molded plastic shields can be used at temperatures up to 150°F and other electrodes up to 190°F.

**Type E-1P — Less Shield:** This electrode is intended for applications where space prevents the use of other electrodes and where vertical spacing between electrodes is 4" or more.

**Type E-1S-Shielded:** A 2" long electrode assembled in a molded plastic shield 9/16" in diameter. Ideal for use in submersible pump installations and other applications where little clearance is provided for installation.

**Type 13-064700:** This electrode is intended for corrosive liquids. It is 3" long made from a 1/2" diameter rod and available in any of the materials listed below. The type SW wire is attached at the factory and the connection is completely sealed with PVC and bonded to the insulation of the SW wire.

**Type SW Suspension Wire:** Designed to provide maximum strength and insulation, Type SW wire should always be used with BIW wire suspension electrodes to assure that a water-tight seal is accomplished by the packing in the electrode. The wire is single conductor 18 gauge, 41 strand copper with 4/64" vinyl insulation.

**Type E-1P-Shielded:** This electrode is approximately 4" long and assembled in a molded plastic insulating shield 1 7/16" in diameter. Designed for general purpose use, it is ideal for elevated tanks, sewage pumping stations, and deep well installations.

**CATALOG NUMBER**  
6013—SW—10



|                           |  |
|---------------------------|--|
| Specify Length<br>In Feet |  |
| Old No. 01-130500         |  |

6013—W1

CATALOG SECTION

|    | ELECTRODE TYPE   | ELECTRODE MATERIAL | OLD PART NO. |
|----|------------------|--------------------|--------------|
| W1 | E-1P With Shield | Brass              | 13-020600    |
| W2 | E-1P With Shield | 303 Stainless      | 13-020700    |
| W3 | E-1P Less Shield | Brass              | 13-052700    |
| W4 | E-1P Less Shield | 303 Stainless      | 13-052600    |
| W5 | E-1S With Shield | Brass              | 13-022000    |
| W6 | E-1S With Shield | 303 Stainless      | 13-024300    |

These electrodes are field assembled and the required amount of Type SW wire must be ordered as a separate item. See above.

NOTE — When wire suspension electrodes are to be used with electrode plugs, or Type E or Type AE-2 electrode holders, wire connectors must also be ordered for each electrode. See above.

6013—W7

CATALOG SECTION

|     | ELECTRODE TYPE         | ELECTRODE MATERIAL | OLD PART NO. |
|-----|------------------------|--------------------|--------------|
| W7  | 13-064700 With SW Wire | 316 Stainless      | 13-064702    |
| W8  | 13-064700 With SW Wire | Monel              | 13-064703    |
| W9  | 13-064700 With SW Wire | Nickel             | 13-064704    |
| W10 | 13-064700 With SW Wire | Carpenter 20       | 13-064705    |
| W11 | 13-064700 With SW Wire | Hastelloy B        | 13-064707    |
| W12 | 13-064700 With SW Wire | Hastelloy C        | 13-064706    |
| W13 | 13-064700 With SW Wire | Titanium           | 13-064709    |

10

|                                |  |
|--------------------------------|--|
| Type SW Wire<br>Length In Feet |  |
|--------------------------------|--|

These electrodes come complete with the Type SW wire permanently attached to the electrode. Lengths must be specified when ordering.

## ELECTRODE MATERIAL SELECTION

The chart below suggests electrode material for some typical liquids. Electrode corrosion is difficult to predict because the rate of corrosion is effected by many factors such as: concentration, temperature and impurities. Therefore, this information should be used as a general guide, and the final choice should be determined from actual application conditions based on previous experience and knowledge.

| ELECTRODE MATERIAL | TYPICAL LIQUID TO BE CONTROLLED   |
|--------------------|---|
| Brass              | Soft Water, Condensate  |
| 316 SS             | Water, Sewage, Beer, Alcohol, Food Products, Chemicals, Many Mild Acids |
| Monel              | Acetic Acid, Sea Water  |
| Nickel             | Boric Acid, Calcium Hydroxide   |
| Carpenter 20       | Sulphuric Acid, Alum Solutions  |
| Hastelloy B        | Hydrochloric Acid   |
| Hastelloy C        | Hydrofluoric Acid   |
| Titanium           | Phosphoric Acid, Brine Ferric Chloride, Hot Nitric Acid                 |
| Carbon Tip         | Hydrochloric Acid<br>Carbonated Water                                   |

Contact Factory for specific recommendations.

## SOLID ROD ELECTRODES

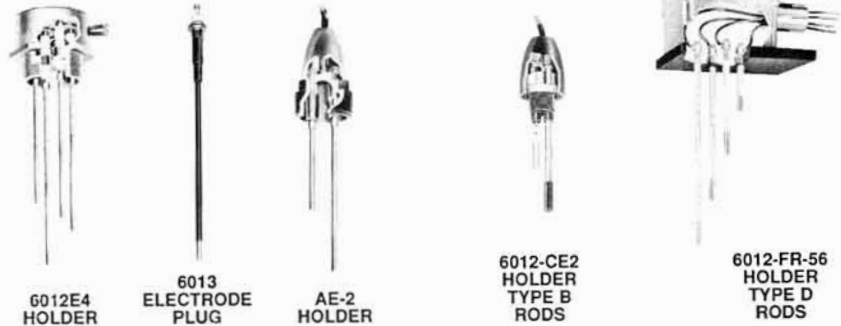

### TYPE A RODS

Solid rod electrodes are generally used where relatively short lengths of 6 feet or less are required. Care should be exercised when specifying lengths over 6 feet. Longer rods and those installed horizontally should be insulated. After cutting insulated rods, strip about 1 inch of insulation off lower end to expose the bare rod.

**TYPE A** electrode rods are 1/4" diameter and have 1/4-20 thread for use with electrode plugs, and Type E and Type AE-2 electrode holders. A boot made of the sheath material is furnished to protect and insulate the lower side of the electrode plug.

**TYPE B** electrode rods are 1/4" diameter and are tapped 6-32 for use only on Type CE-2 and CE-3 holders. Lengths over 12 inch should be insulated and lengths over 30 inch not recommended.

**TYPE C** electrode rods are 1/4" diameter and have the upper end machined with a shoulder and 10-24 thread to assemble into Type KF holders.

**TYPE D** electrode rods are 1/4" diameter are similar to Type C except the upper end is machined to a length that fits only Type FR holders.

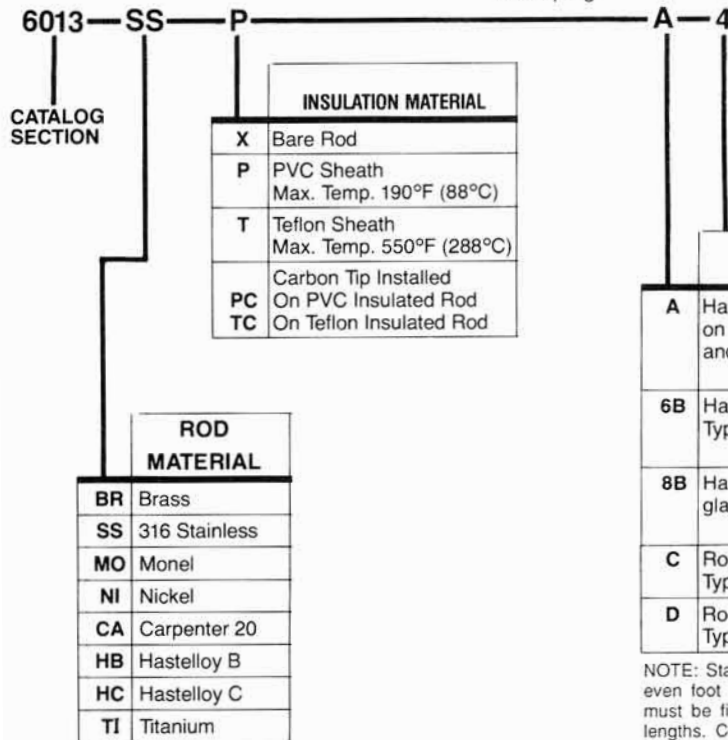

NOTE: Standard stock rods are furnished in even foot increments up to 10 ft. long, and must be field cut for intermediate operating lengths. Contact Factory for pricing on other lengths and materials.

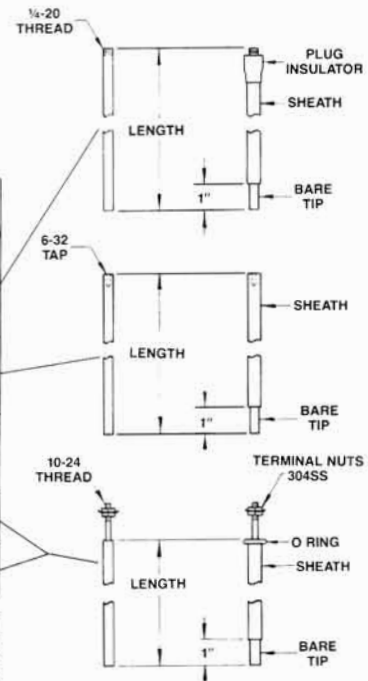



### GLAND PLUG AND ROD ASSEMBLY



The packing gland construction of these units provides additional strength for electrodes on applications where there is vibration, shock or side thrust against the electrode. Installations include detecting the presence or absence of fluids in shipboard bilge discharge lines, or coal slurry pipelines.

The lower plug body is available in most of the same materials as the electrode rods so that these assemblies are quite suitable for many corrosive conditions. With teflon insulated rods they are rated for use up to 250 psi and 400°F (204°C).

These gland plug electrode assemblies can also be used in the Type E electrode holders instead of the standard electrode plugs.

The gland plug assemblies are separately ordered for field assembly.

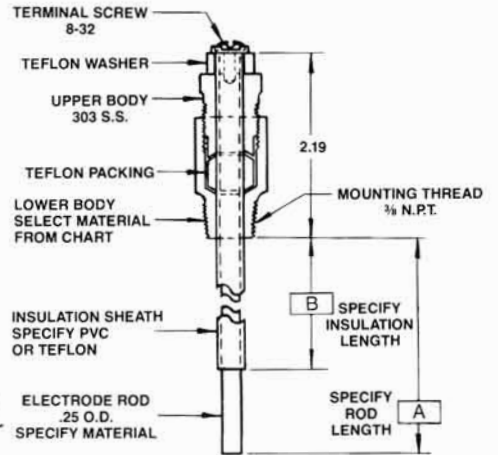

CATALOG NUMBER  
6013 — GP — CA

|     | LOWER BODY MATERIAL | OLD PART NUMBER     |
|-----|---------------------|---------------------|
| 303 | 303 Stainless       | 12-065800/12-065900 |
| 316 | 316 Stainless       | 12-074600           |
| MO  | Monel               | 12-075800           |
| NI  | Nickel              | 12-079600           |
| CA  | Carpenter 20        | 12-074700           |
| TI  | Titanium            | 12-078000           |

SS — P — 8B — 4

Electrode Rod Details  
See Previous Page

A dimension is electrode length  
B dimension is insulation length

### ADJUSTABLE GLAND ELECTRODE ASSEMBLY

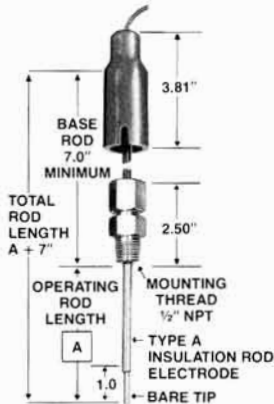

B|W adjustable gland electrode holders are designed for use in applications that require occasional changing of the high or low level control settings. Typical installations include conveyor feed, liquid proportioning, and container filling machines.

Made of 303 stainless steel with positive pressure-tight 1/2" pipe thread mounting plus Teflon or Neoprene insulation and packing. These holders are used with insulated solid rod electrodes of any desired length. To adjust level settings, simply loosen the top of the holder and slide the electrode up or down to required depth. Electrodes must be insulated over the full range of adjustability.

CATALOG NUMBER  
6013 — AGP — 15

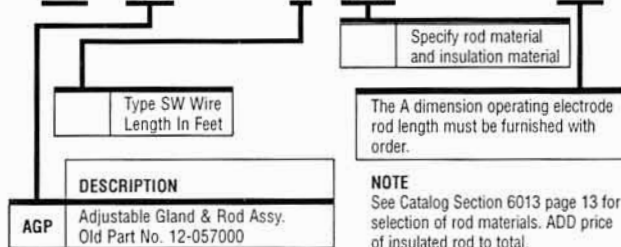

NOTE  
See Catalog Section 6013 page 13 for selection of rod materials. ADD price of insulated rod to total.

### RUGGEDIZED ELECTRODE ASSEMBLY

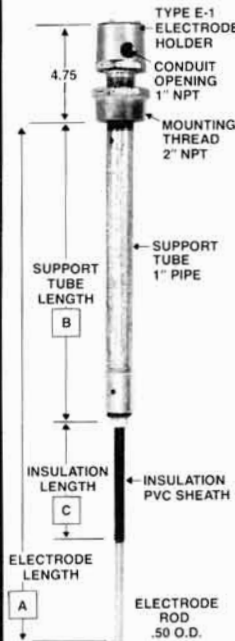

These Type REA electrode assemblies are very strong for use on heavy solutions, particularly when they are being agitated with a mixer. Applications include clay or starch solutions used for sizing in the manufacturing of paper products.

The Type E-1 holder provides water-tight protection for the electrode connection and is available in cast iron, brass or 316 S.S. The support tube which provides strength to prevent deflection of the 1/2" OD stainless rod is available in galvanized steel or other materials such as stainless steel.

CATALOG NUMBER  
6013 — REA  
Old Part No. 12-070600

When placing an order or requesting a quotation, specify the required lengths for dimensions A, B, & C, and the type of material for the holder and support tube.

## SMALL BUSHING AND ROD ASSEMBLIES

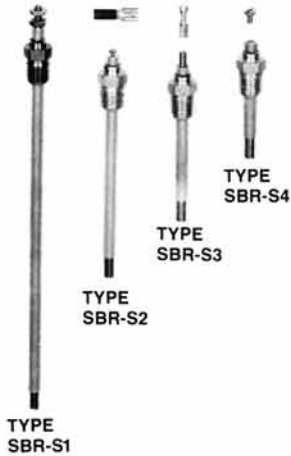

Ametek offers a variety of these small electrode assemblies to meet special OEM situations for single electrodes. The bushing has a 1/4" NPT pipe thread for pressure-tight mounting and is available in either cadmium plated steel or 316 S.S. The electrode rod is 1/4" O.D. and must be insulated for at least 1" below the bushing. The available PVC or teflon insulated rod materials are listed on page 35. There is a choice of four methods to connect the electrode lead wire.

CATALOG NUMBER  
6013 — SBR — S1 — S

| TYPE OF WIRE CONNECTION |                 |
|-------------------------|-----------------|
| S1                      | Double Nut      |
| S2                      | Push-On Spade   |
| S3                      | Push-On Bayonet |
| S4                      | 6-32 Screw      |

Minimum Order  
25 pieces

For quotation advise, type of wire connection, bushing material, material and length of insulated rod.

## CONCENTRIC ELECTRODE ASSEMBLIES

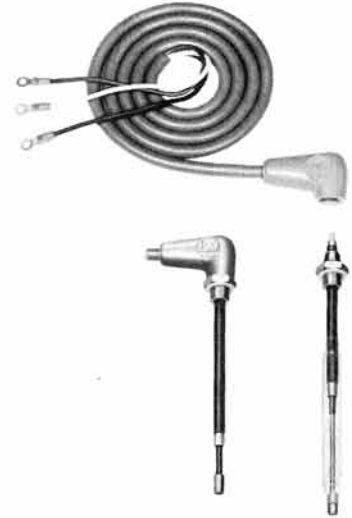

These assemblies are primarily for OEM applications requiring two short electrodes and where space is limited to install them. While developed for carbonator level control, they are suitable for any small tank for use up to 150 psi and 170°F (77°C). The mounting bushing is made of 316 S.S. with 1/2"-20 machine thread, and a nylon gasket is provided. The snap-on cord set has a three conductor type SJT cord which provides ground connection to the mounting bushing, as well as the two electrode leads.

For a quotation advise the length of both electrodes, the length of the cord set, and the type of termination for the wire leads.

CATALOG NUMBER  
6013 — CEA — S

Minimum Order  
25 pieces

## SPACERS FOR INSULATED ELECTRODE RODS

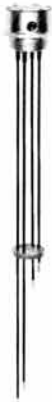

B/W rod spacers are used to stiffen long electrode rod assemblies in those situations where movement of the liquid would tend to deflect the rods. They must never be attached to bare electrode rods because liquid on the surface of the spacer could short between electrodes preventing proper operation of the B/W control relays.

The PVC spacers include heat shrinkable PVC sleeves for attaching them to PVC insulated rods. The teflon spacers have heat shrinkable teflon sleeves to secure them to teflon insulated rods.

CATALOG NUMBER  
6013 — RS2 — P

|     | SPACER DESCRIPTION |                          |
|-----|--------------------|--------------------------|
|     | Number Of Rods     | For Use With Holder Type |
| RS1 | 2                  | E-2                      |
| RS2 | 3                  | E-3                      |
| RS3 | 4 to 7             | E-4 to E-7               |
| RS4 | 2                  | KF-1                     |
| RS5 | 2 to 4             | KF-2 or KF-2JB           |
| RS6 | 2 to 7             | KF-3 or KF-4             |
| RS7 | 2 to 5             | FR-56                    |

| INSULATION MATERIAL |        |
|---------------------|--------|
| P                   | PVC    |
| T                   | Teflon |

NOTE  
Contact factory for quote on special assemblies consisting of electrode holders with insulated electrode rods and spacers attached.

## MOISTURE SENSOR

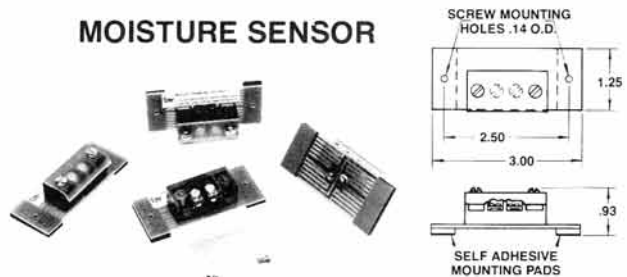

The Type MSA moisture sensor is a compact low cost device used to detect water leakage into areas such as computer room subfloors, communication vaults, below grade ductwork, floors in basements, storage areas or equipment rooms. It is easily attached to a floor or wall surface by the self adhesive strips or the mounting screws provided.

While designed as a sensor for the Series 41 Alarm Panel described in Catalog Section 8041, they can also be used to operate any of the B/W control relays. The relay or alarm is actuated when moisture bridges adjacent printed circuit paths on the underside of the sensor.

CATALOG NUMBER  
6013-MSA-1  
Old Part No. 13-074400