

## Unifloat™ Level Sensors

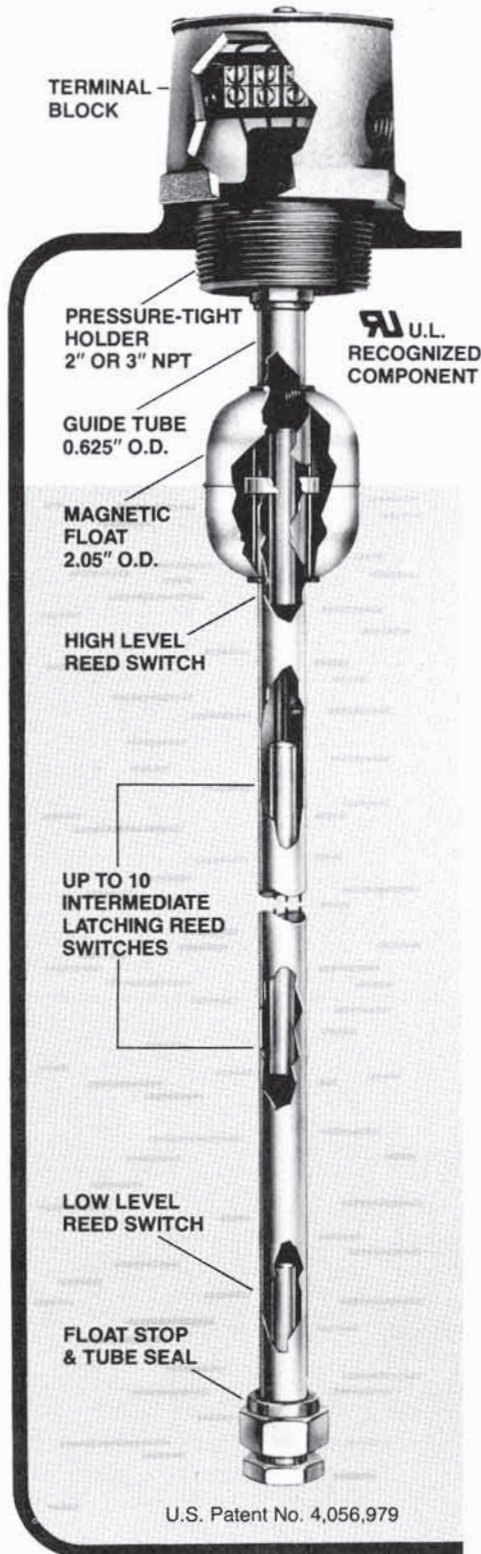

### DESCRIPTION

The B/W Unifloat level sensing system was developed especially to permit simple, low-cost installation and ease of adjustment in service for a broad range of applications requiring accurate multiple function/multiple level control of any type of liquid.

#### FOUR BASIC COMPONENTS

As illustrated at left, this advanced new system consists of just four basic components:

- (1) A single **MAGNETIC FLOAT** that is free to travel up and down with the rise and fall of liquid. Standard material is 316 S.S.
- (2) A **GUIDE TUBE** of any practical length with one float stop at the bottom. Available in brass or 316 S.S.
- (3) A pressure tight **WEATHER-PROOF** holder available in cast iron or 316 S.S. to support the guide tube from the top of the tank.
- (4) Up to 12 **REED SWITCHES** suspended at any desired operating levels in the guide tube. Two types of the B/W patented magnetically latching reed switches are available.

#### Operating Viscosity

Up to 1500 CP  
(centipose)  
Up to 6000 SSU  
(saybolt universal seconds)

#### Operating Pressures

Minimum  
Vacuum  
To 14.7 psi  
Maximum  
500 psi  
3450 kPa

#### Operating Temperatures

Minimum  
0°F  
-19°C  
Maximum  
250°F\*  
121°C\*

\*Consult Factory For Temperatures over 250°F

#### CHOICE OF TWO REED SWITCHES

##### CONTACT RATINGS

MAXIMUM VOLTS	MAXIMUM CURRENT	
	A.C.	D.C.
25	440 ma	400 ma
50	220 ma	200 ma
120	90 ma	80 ma

#### TYPE C REED SWITCH

One lead with grounded contact



Up to 7 in 2 inch holder.  
Up to 12 in 3 inch holder.

Common side of each switch must connect to grounded side of the same power supply.

Ideal for use with B/W control relays.

Part #14000131

#### TYPE I REED SWITCH

Two leads with isolated contact



Up to 4 in 2 inch holder.  
Up to 6 in 3 inch holder.

Individual switches can be used in different circuits.

Greater flexibility on applications with conventional relays and devices.

Part #14000151

## FEATURES AND ADVANTAGES:

Because of its inherent simplicity, the BIW Unifloat™ Level Sensor concept provides many features and advantages not offered by other float type level sensing devices. Among them:

**Fewer Parts/Lower Costs**—Use of one free-moving float to actuate up to 12 hermetically sealed and encapsulated reed switches eliminates expense and problems involved in mounting a separate float plus float stops at each operating level.

**Ease of Installation**—Suspending all reed switches on a common circuit return line simplifies assembly and installation. Just slide switches up or down to desired control levels and position them in guide tube. Then mount the tube and its supporting holder through top of the tank, and make electrical connections to BIW relays. Because control circuit voltage between reed switches and relays is normally quite low, no special wiring is required. A numbered terminal block in the holder permits quick, easy field connections to the external relays, alarms, valves or whatever is used to perform the desired functions.

**Simple Level Adjustment**—Unifloat also permits quick and easy adjustment of control levels if required to meet changing operating conditions. Simply remove the internal terminal block and reed switch assembly through the top of the holder. Add, remove or change position of switches to any new levels desired and replace in the housing. No need to break any tank connections or disturb any material in the tank.

**Greater Reliability**—Power failures are not supposed to occur. But occasionally they do. No problem with Unifloat. Because, as the free-moving float passes each control level, the unique latching feature of the switches in the guide tube assures detection of changing level even during periods of no power, plus immediate resumption of normal operation when power is restored.

**Greater Versatility** — Another exclusive feature of BIW Unifloat systems is the fact the each reed switch can be used for either DIRECT or INVERSE operation. In other words, the operation of each switch can be quickly changed from NO to NC by simply reversing position of the reed switch instead of reversing the magnetic float.

### DIRECT OPERATION

The reed switch contact is **NORMALLY OPEN** and **CLOSES ON RISING LEVEL**.

With the float magnet below the switch actuation point, the contact is open until rising level causes the float to raise to the actuation point. The contact then closes and because of the patented BIW magnetic latching feature, it will remain closed until falling level brings the float back down and past the actuation point.

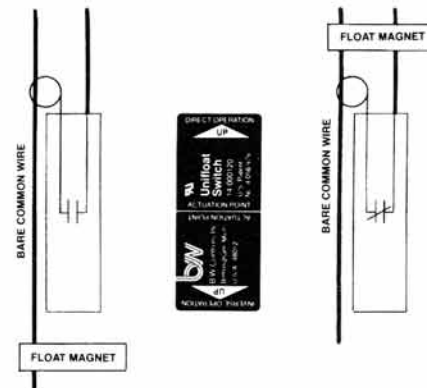

The Type C Switch is shown.  
It attaches to the common wire with a spring clip.

### INVERSE OPERATION

The reed switch contact is **NORMALLY CLOSED** and **OPENS ON RISING LEVEL**.

With the float magnet below the switch actuation point, the contact is closed and because of the patented magnetic latching feature, will remain closed until rising level causes the float to raise past the actuation point. The contact will then remain open until falling level brings the float back down to the actuation point causing the contact to latch in the closed position.

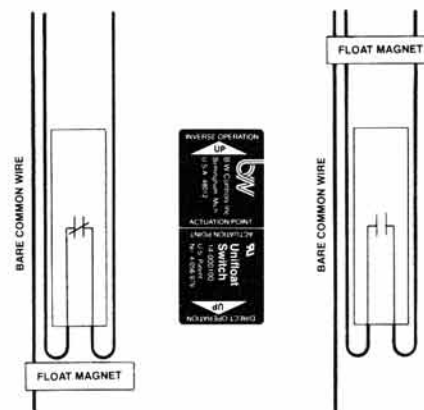

The Type I switch is shown.  
It attaches to the common wire with plastic tape.

## TERMINAL BLOCK ARRANGEMENTS FOR TYPE C REED SWITCHES (All contacts have a common ground)

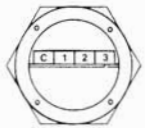

2 INCH NPT HOLDER FOR 1 TO 3 SWITCHES

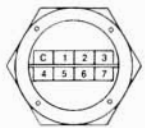

2 INCH NPT HOLDER FOR 4 TO 7 SWITCHES

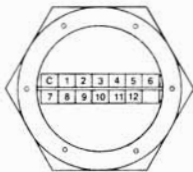

3 INCH NPT HOLDER FOR 8 TO 12 SWITCHES

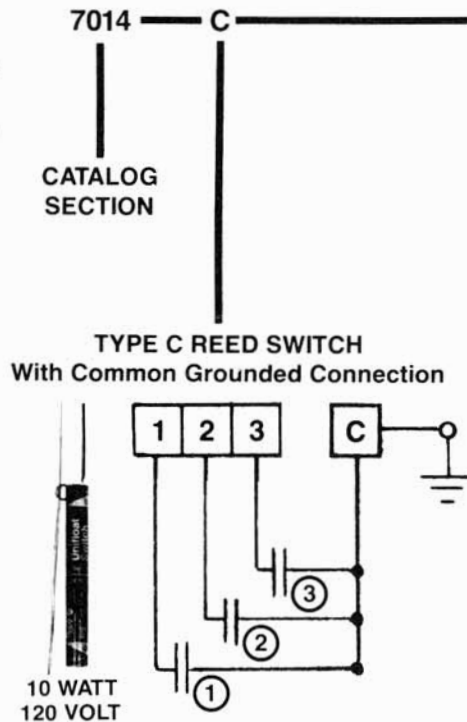

NUMBER OF SWITCHES		
1	1 magnetically latched reed switches	
2	2 magnetically latched reed switches	
3	3 magnetically latched reed switches	
4	4 magnetically latched reed switches	
5	5 magnetically latched reed switches	
6	6 magnetically latched reed switches	
7	7 magnetically latched reed switches	
8	8 magnetically latched reed switches	3 IN. HOLDER
9	9 magnetically latched reed switches	
10	10 magnetically latched reed switches	
11	11 magnetically latched reed switches	
12	12 magnetically latched reed switches	

## TERMINAL BLOCK ARRANGEMENTS FOR TYPE I REED SWITCHES (Isolated Contacts)

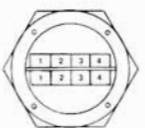

2 INCH NPT HOLDER FOR 1 TO 4 SWITCHES

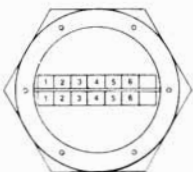

3 INCH NPT HOLDER FOR 5 TO 6 SWITCHES

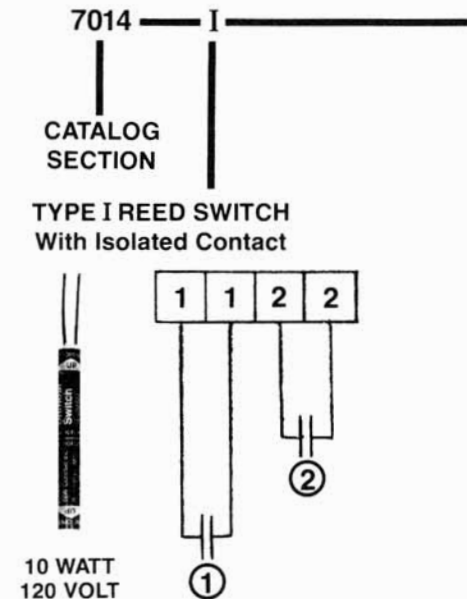

NUMBER OF SWITCHES		
1	1 magnetically latched reed switches	
2	2 magnetically latched reed switches	
3	3 magnetically latched reed switches	
4	4 magnetically latched reed switches	
5	5 magnetically latched reed switches	3 IN. HOLDER
6	6 magnetically latched reed switches	

### Unifloat® CATALOG NUMBERING SYSTEM

**A** ————— **6** — **SS** —————

See page 54 for information regarding switch settings and direct or inverse operation.

HOLDER MATERIAL & SIZE	
<b>A</b>	Cast Iron 2" & 3" NPT
<b>B</b>	316 Stainless Steel 2" NPT 1-7 Switches
<b>C</b>	316 Stainless Steel 3" NPT 8-12 Switches

GUIDE TUBE MATERIAL	
<b>B</b>	BRASS
<b>SS</b>	316 STAINLESS STEEL

Length of Tube For Reed Switch Set Lengths (Dimension "L" in feet)	
1	1 Foot
2	2 Feet
3	3 Feet
4	4 Feet
5	5 Feet
6	6 Feet
7	7 Feet
8	8 Feet
9	9 Feet
10	10 Feet
11	11 Feet
12	12 Feet

Consult factory for lengths and/or materials not listed.

#### ORDERING INFORMATION

1. Specify Unifloat with a complete catalog number.
2. Specify switch setting information by including a switch specification chart from page 55.
3. Provide details on the nature of the liquid being controlled.

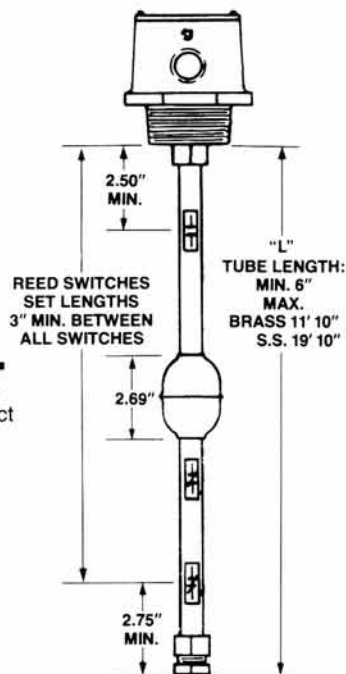

**TUBE LENGTH:** Tube will be cut 2.75" longer than maximum switch set length unless otherwise specified.

#### NOTES

1. If switch setting information is not included with order, all switches will be installed for direct operation and set at maximum lengths.
2. Unless otherwise specified, factory assembled Unifloats will have the switches set for actuation based on 1.0 S.G. for water.

**B** ————— **10** — **SS** —————

See pages 54 & 55 for information regarding switch settings and direct or inverse operation.

HOLDER MATERIAL & SIZE	
<b>A</b>	Cast Iron 2" & 3" NPT
<b>B</b>	316 Stainless Steel 2" NPT 1-4 Switches
<b>C</b>	316 Stainless Steel 3" NPT 5-6 Switches

GUIDE TUBE MATERIAL	
<b>B</b>	BRASS
<b>SS</b>	316 STAINLESS STEEL

Length of Tube For Reed Switch Set Lengths (Dimension "L" in feet)	
1	1 Foot
2	2 Feet
3	3 Feet
4	4 Feet
5	5 Feet
6	6 Feet
7	7 Feet
8	8 Feet
9	9 Feet
10	10 Feet
11	11 Feet
12	12 Feet

Consult factory for lengths and/or materials not listed.

## DIMENSIONS AND DETAILS

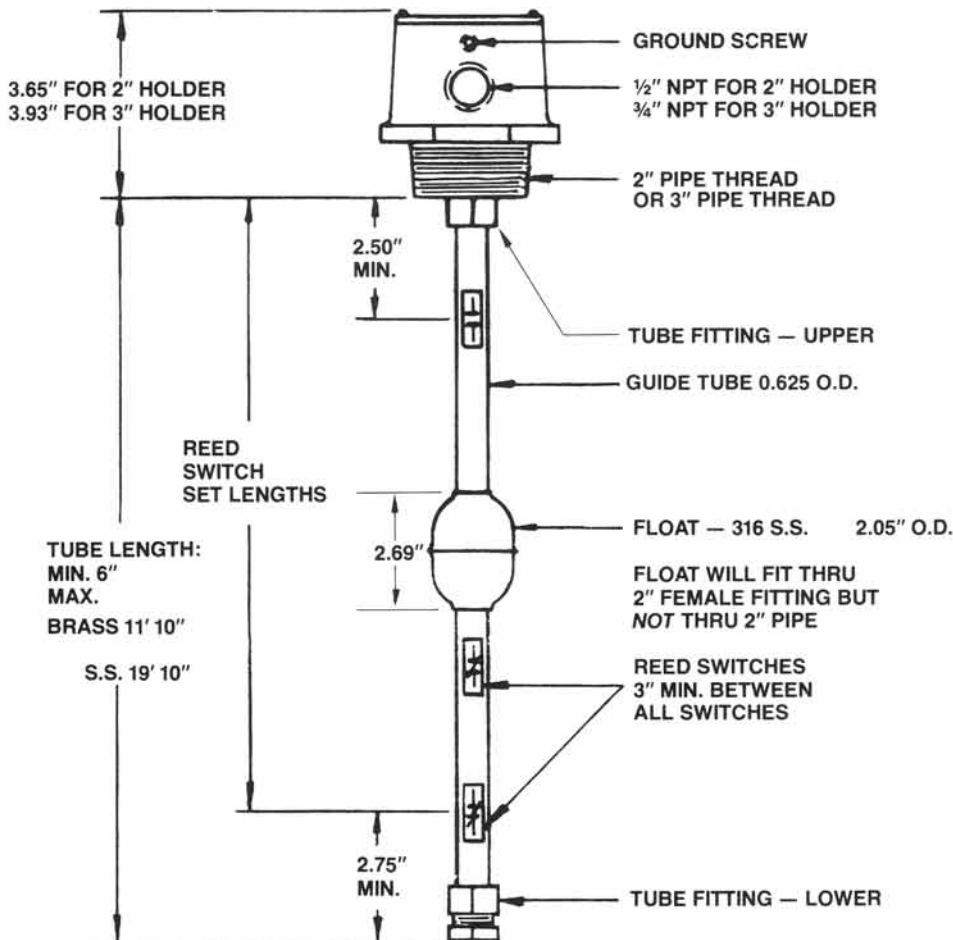

### Operating Pressures

Minimum	Vacuum to 14.7 psi
Maximum	500 psi 3450 kPa

### Operating Temperatures

Minimum	0°F -19°C
Maximum	250°F* 121°C*

\*Consult Factory For Temperature over 250°F

### Operating Viscosity

Up to 1500 CP  
Up to 6000 SSU

**IMPORTANT:** The reed switches are rated for 10 watts and the maximum voltage and current load must not be exceeded.

Volts	Maximum Current	
	AC	DC
25	440 MA	400 MA
50	220 MA	200 MA
120	90 MA	80 MA

Just before installation into the tank, slide the float up and down the full length of tube to set the switches in their normal condition.

## REED SWITCH SETTINGS

Each reed switch is marked with the actuation point and the differential travel is 0.1 inch. Switch actuation will depend on the actual specific gravity of the liquid being controlled, and unless otherwise specified, factory assembled units will have switch settings based on water with a specific gravity of 1.0. Adjustment for other specific gravities is shown in the table.

### SPECIFIC GRAVITY ADJUSTMENT

S.G.	Subtract from Length	S.G.	Add to Length
1.5	0.37 in.	1.0	None
1.4	0.31 in.	0.9	0.12 in.
1.3	0.25 in.	0.8	0.27 in.
1.2	0.18 in.	0.7	0.48 in.
1.1	0.10 in.	*0.65	0.62 in.
1.0	None	*Recommended Minimum	



# B|W Controls

Unifloat™ Level Sensors

## REED SWITCH SPECIFICATION CHARTS

### TYPE C REED SWITCH

(All contacts have a common ground)  
Maximum rating 10 watts at 120 volts  
AC or DC.

#### BARRIER TERMINAL BLOCK IN HOLDER

No. 6 Screw — Saddle Clamp  
Max. Wire Size: #14 A W G

#### ONE LEAD WITH GROUNDED CONTACT

Up to 7 switches in 2 inch holder.  
Up to 12 switches in 3 inch holder.

Common side of each switch must connect to grounded side of the same power supply.

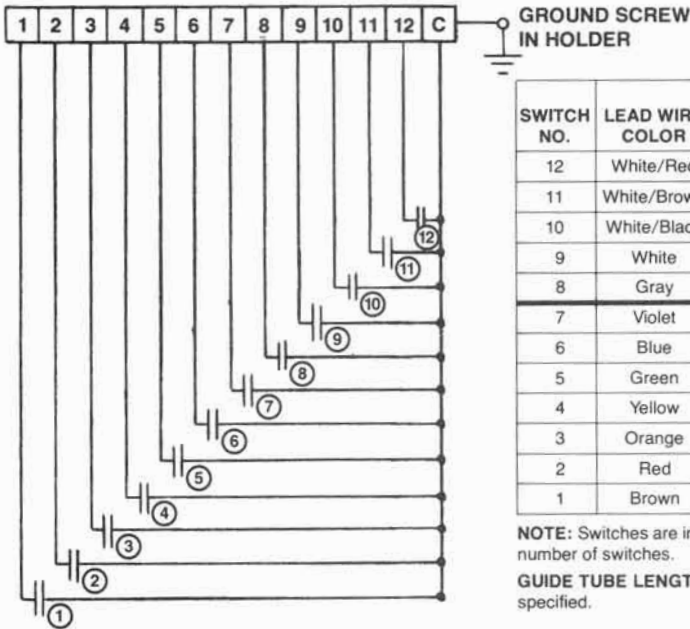

SWITCH NO.	LEAD WIRE COLOR	TERMINAL NO.	FUNCTION	SWITCH OPERATION		SET LENGTH (INCHES)
				DIRECT	INVERSE	
12	White/Red	12				
11	White/Brown	11				
10	White/Black	10				
9	White	9				
8	Gray	8				
7	Violet	7				
6	Blue	6				
5	Green	5				
4	Yellow	4				
3	Orange	3				
2	Red	2				
1	Brown	1				

**NOTE:** Switches are installed with No. 1 as the lowest in the guide tube and working upward using the required number of switches.

**GUIDE TUBE LENGTH:** Tube will be cut 2.75" longer than the maximum switch set length unless otherwise specified.

### TYPE I REED SWITCH

(All isolated contacts)  
Maximum rating 10 watts at 120 volts  
AC or DC.

#### BARRIER TERMINAL BLOCK IN HOLDER

No. 6 Screw — Saddle Clamp  
Max. Wire Size: #14 A W G

#### TWO LEADS WITH ISOLATED CONTACT

Up to 4 switches in 2 inch holder.  
Up to 6 switches in 3 inch holder.

Individual switches can be used in different circuits.

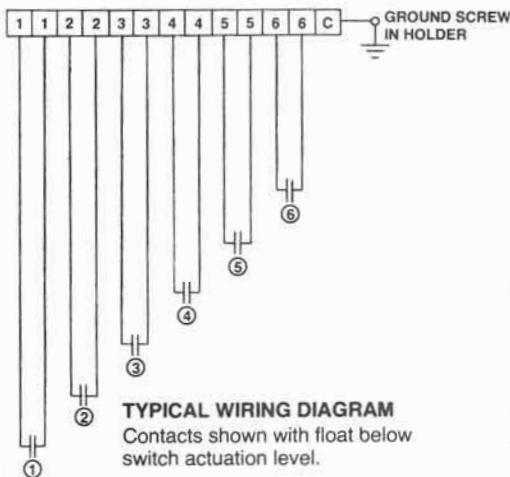

SWITCH NO.	LEAD WIRE COLOR	TERMINAL NO.	FUNCTION	SWITCH OPERATION		SET LENGTH (INCHES)
				DIRECT	INVERSE	
6	Blue	6				
5	Green	5				
4	Yellow	4				
3	Orange	3				
2	Red	2				
1	Brown	1				

**NOTE:** Switches are installed with No. 1 as the lowest in the guide tube and working upward using the required number of switches.

**GUIDE TUBE LENGTH:** Tube will be cut 2.75" longer than the maximum switch set length unless otherwise specified.

Above contacts shown as direct operation. For inverse operation show contact closed.

⊥ Direct Operation.

⊥/ Inverse Operation.

## OTHER APPLICATIONS

### WITH TYPE C REED SWITCH Having Common Grounded Contact

The line diagram below shows the wiring method recommended when operating conventional relays and devices rather than BIW relays. To meet UL requirements, the control power must be from an isolation transformer with the common side grounded. This means that the Unifloat switches are connected in the grounded side of the relay coils rather than the hot side. If this causes a circuit design problem, then the Type I isolated contact reed switches should be used in the Unifloat.

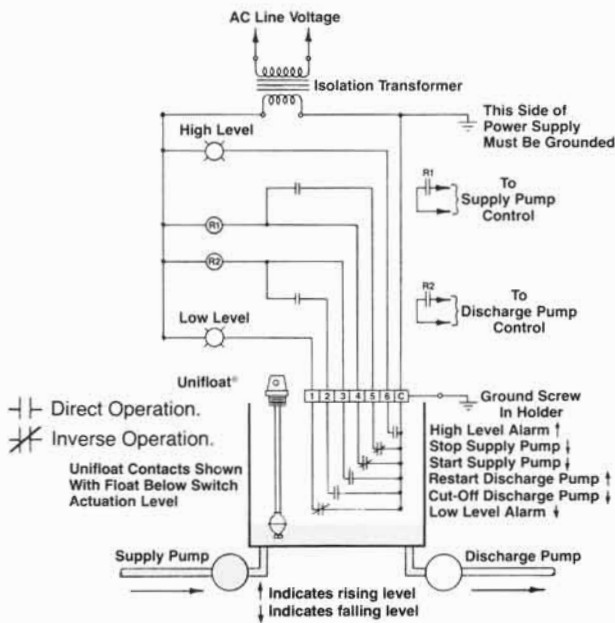

### WITH TYPE I REED SWITCH Having Isolated Contact

The versatility of the Type I reed switch is shown in the line diagram below. They can be wired in the hot side of the control voltage and be independently wired in various control circuits. While a ground screw is provided in the holder, there is no need to ground the reed switch leads. Contacts are rated 10 watts at up to 120 volts AC or DC and the maximum voltage and current ratings must not be exceeded.

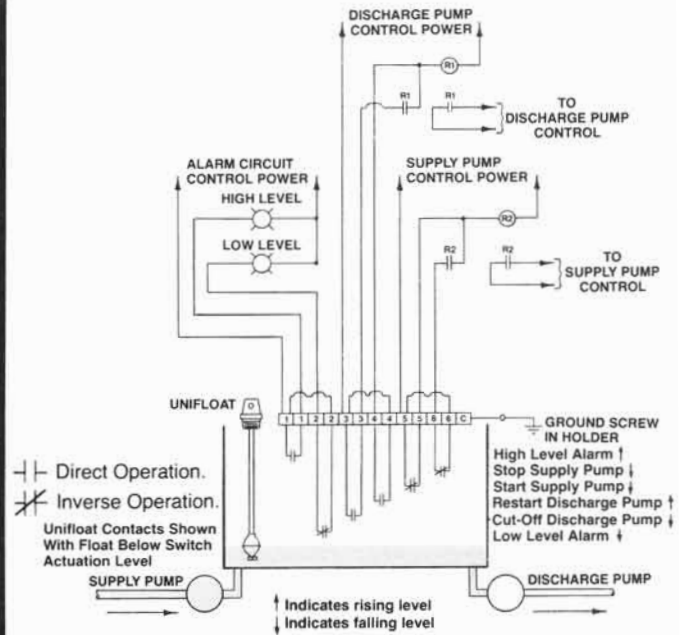

## ACCESSORIES

MOUNTING FLANGES	Cast Iron 125 Lbs. Plain Face	304 SS 150 Lbs. Stainless Steel Raised Face	316 SS 150 Lbs. Stainless Steel Raised Face
2 x 6 Companion, 2 inch (Weight 5 lbs.)	04186500	04291013	04291002
2 x 7½ Reducing, 2 x 3 inch (Weight 9 lbs.)	04186400	04291113	-
2 x 9 Reducing, 2 x 4 inch (Weight 15 lbs.)	04193600	04294113	04587275
3 x 7½ Companion, 3 inch (Weight 9 lbs.)	04193500	04291213	-
3 x 9 Reducing, 3 x 4 inch (Weight 15 lbs.)	04197600	04294213	-

DESCRIPTION
Relay output module having 4 S.P.D.T., 10 AMP relays and indicating lights Part No. 40070700
8" Dia. float for liquids having a specific gravity of .45 or more. (An access hole in the tank is required to attach the 8" float to the tube or a 10" flange adapter)