

BIW Controls

Electrode Holders/Electrodes

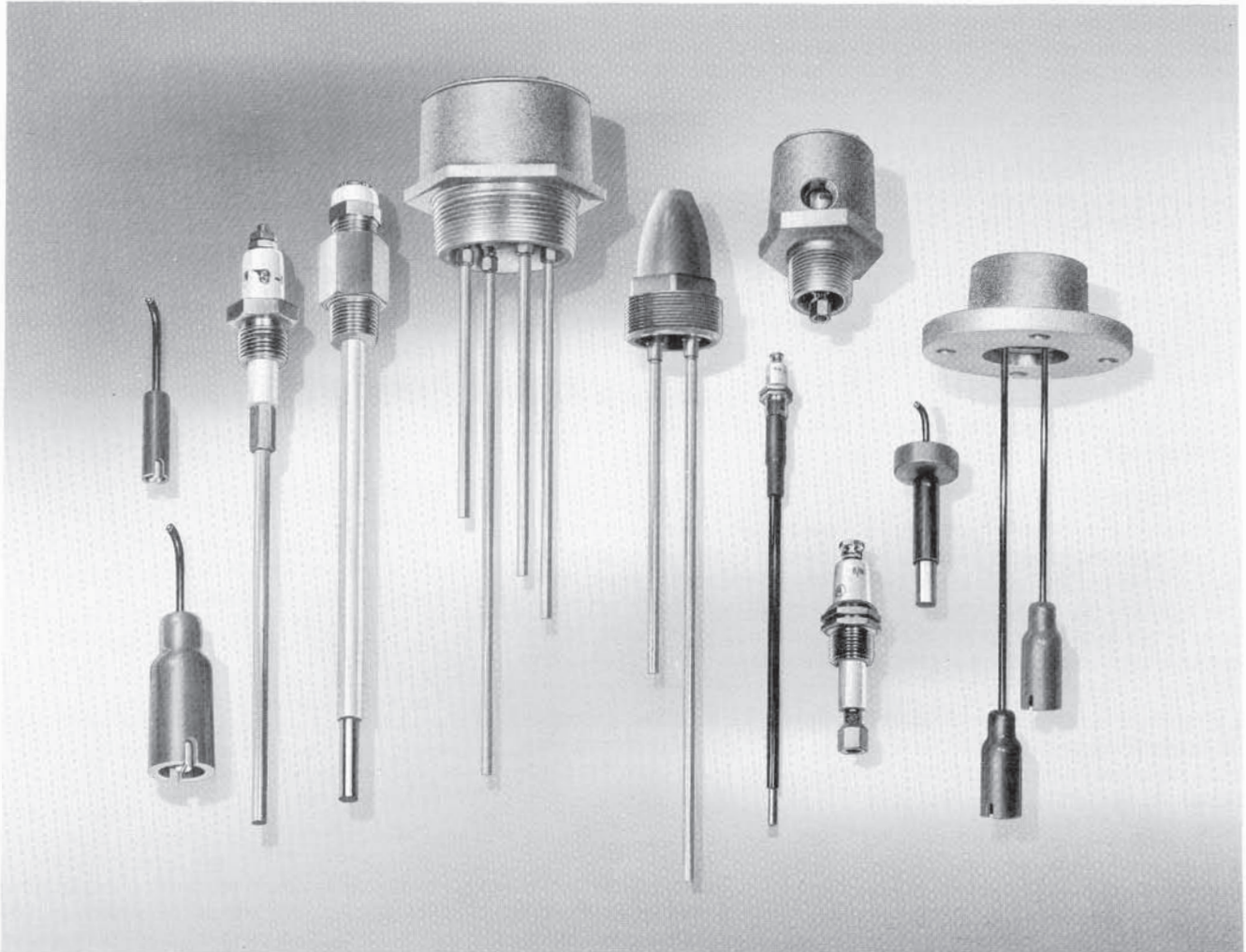

Since its introduction in 1933, the original BIW concept of utilizing the electrical conductivity of most liquids as a means of achieving liquid level control has won widespread acceptance as the most versatile and reliable system of its kind. In the BIW system of floatless liquid level control, electrodes or probes are suspended in the container to make contact with the liquid and thus complete a circuit which actuates a BIW relay. The relay contacts in turn are used for a wide range of applications such as controlling pumps and valves, or sounding alarms on level conditions.

Electrodes and holders should be selected according to the specific characteristics of the liquid involved, the lengths required to obtain the desired control of levels, and the physical nature of the container. Because of these factors, the BIW line of electrodes and holders presented in this section has been developed to provide a practical,

economical solution to almost every conceivable application and installation problem. When necessary, special equipment can also be supplied to meet specific needs.

Electrodes are normally used with a suitable holder and, wherever possible, should be suspended vertically downward from the top of the tank or other vessel containing the liquid. Also, electrodes are connected to the sensing circuit of a BIW relay. While this is a low energy circuit with inherently limited low current, the electrodes are terminals of a live electrical circuit and must be installed to prevent contact by unauthorized personnel.

Whenever electrodes are installed in an explosive hazardous area, the BIW Series 5300 or 5510 relays with FM & CSA approved intrinsically safe sensing circuit must be used. See Catalog Section 5300.

SELECTING AND ORDERING ELECTRODE EQUIPMENT

The first step in selecting electrode equipment is to establish the overall general conditions for the specific application. The control functions desired will determine the BIW relays to be used, and also the number of electrodes required. Factors to be considered include: type of service such as indoor or outdoor installation; type of container for the liquid; nature, temperature and pressure of the liquid; any corrosive or hazardous condition existing; number and length of electrodes.

BIW electrode type of level control may be used on liquids that have sufficient conductivity to operate one of the BIW control relays, and they include potable water, steam condensate D.I. water, sewage, slurries acids, alkalies, salts, beer, blood, alcohols, milk, juices, water soluble oils, brine, plating solutions, baby foods, soups, and many others.

The BIW Unifloat® shown at the bottom of this page should be used for non-conducting liquids such as fuel and vegetable oils, gasolines and many organic chemicals that have specific resistance above 12 megohms-cm (Conductivity less than 0.1 micromho).

To assist in the selection of electrode equipment see the following pages where pictures and basic information is furnished for quick comparison of available types.

ELECTRODE HOLDERS

In general BIW electrode holders have mounting provisions to mate with standard pipe fittings on the vessel, and the pressure and temperature ratings for the various types are shown on the specification pages. Most holders have water-tight protection for the conduit or cable entrance. Where possible, all electrodes should be grouped into a single holder and mounted on top of the tank with the electrodes extending vertically downward.

Standard electrode holders are suitable for location in explosive hazardous areas, when BIW Series 5300 or 5510 relays with intrinsically safe sensing circuits are used to operate from the electrodes.



BIW Unifloat®

- Ideal for non-conductive liquids such as gasoline, fuel oil, oily waste and organic chemicals.
- Just one float operates switches for up to 12 sensing levels.
- Simple level adjustment without disturbing tank connections.
- See Catalog Section 7014

ELECTRODE HOLDER

For mechanical mounting and electrical isolation.



ELECTRODE

Solid rod or wire suspension types are available.

ORDERING INFORMATION

For Electrode Holders

Provide *complete* catalog number which will include number of electrode provisions and any special features.

For Solid Rod Electrodes

Provide *complete* catalog number which will include type, material and length.

For Wire Suspension Electrodes

Provide *complete* catalog number. In most cases the suspension wire and wire connector must be ordered as separate items.

ELECTRODES

Solid rod electrodes are generally used where relatively short lengths of 6 feet or less are required. However, care should be exercised when specifying lengths over 3 feet to be certain there is head room to install them, and that liquid movement will not cause bare rods to deflect to touch one another, causing false relay operation.

Wire suspension electrodes are used for long lengths, and generally are more convenient to field set and adjust for operating lengths.





Electrodes subject to turbulence such as found in batching or slurry mixing applications should be strengthened with spacers, protected with a stilling tube, or Ruggedized Electrodes should be used. Gland electrode assemblies are recommended for installation in pipe lines or other applications where side thrust is to be encountered.







CORROSION RESISTANCE

Ametek offers holders and electrodes in a variety of materials, and a standard arrangement is usually available to meet most situations. However, the rate of corrosion is affected by the concentration and temperature of the liquid as well as the presence of impurities or other compounds. Therefore, corrosion information in this catalog should be used as a general guide and the final choice should be based on previous experience and knowledge for the actual application conditions.

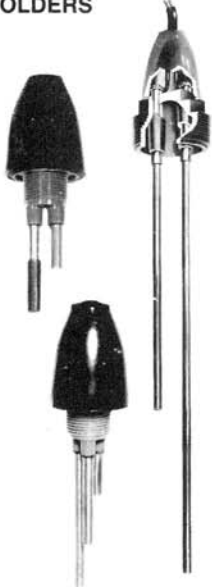
B|W Controls

Electrode Holders/Electrodes

<p>The following chart is provided to assist in selecting the proper Electrode Holder for your application. Refer to the Catalog Sections listed below for dimensions, list prices and additional engineering information.</p> <p>For information on electrodes see Catalog Section 6013 page 43 for wire suspension electrodes and page 44 for solid rod electrodes.</p>	EXTERNAL PIPE THREADED ELECTRODE HOLDERS			ELECTRODE PLUGS		FLANGED CAST IRON ELECTRODE HOLDERS			FLANGED PVC ELECTRODE HOLDERS			
												
MOUNTING ATTACHMENT TO VESSEL	1" NPT	2" NPT	3" NPT	3/8" PTF	3" FLANGE	4" FLANGE	6" FLANGE	1" FLANGE	2" FLANGE	4" FLANGE	5"x6" RECT.	
Number of Electrodes	1	2-3	4-7	1	1-7	1-13	1-13	1 Bare Or 2 Insulated	1-4	1-7	1-5	
Temperature and Pressure of Liquid <small>*Specify #04141300 Electrode Plug</small>	Mat'l.	Max. Temp. °F.	Max. Pressure	Up to 2000 psi	190°F 0 psi	180°F 0 psi with Wire Suspended Electrodes 10 psi with Rod Electrodes						
											Brass	200°F*
		Cast Iron	200°F								500 psi	
			400°F*								250 psi	
316 Stainless	200°F	2000 psi										
		450°F	400 psi									
CORROSION RESISTANCE	Available in Brass, Cast Iron or 316 Stainless			304SS	Cast Iron			Unplasticized Polyvinyl Chloride (PVC)				
Solid Rod Electrode (For lengths less than 6 ft.)	Available			Available	Not Available			Available				
Wire Suspended Electrodes	Available			Available	Available			Available				
Type of Service	Watertight, Outdoor Heavy Duty			Industrial Duty	Watertight, Outdoor Heavy Duty			Industrial Duty PVC for Corrosion Resistance and Watertight				
Electrode Height Adjustability	Solid Rod Electrodes Cut to Desired Length			Adjustable			Adjustable with Wire Suspended Electrodes					
	Catalog Section 6012			Catalog Section 6012	Catalog Section 6012			Catalog Section 6012				

MOLDED EXTERNAL THREADED ELECTRODE HOLDERS			CONDUIT ELECTRODE HOLDERS		CORD GRIP ELECTRODE HOLDERS		ICE-FREE ELECTRODE ASSEMBLY	GLAND ELECTRODE ASSEMBLIES		SPECIAL PURPOSE ELECTRODE ASSEMBLIES
										
1-14 STRAIGHT THREAD	1-14 STRAIGHT THREAD	2" NPT	1/2" NPT or 1/2" PVC	1" NPT or 1" PVC	1/2" NPT	1/2" NPT	4" FLANGE	3/8" NPT	1/2" NPT	VARIOUS
2	3	2	1-4	1-8	1	2	1-9	1	1	1
Up To 200 psi and 350°F		100°F 250 psi 180°F 0 psi	190°F 0 psi		190°F 0 psi		190°F 0 psi	100 psi @ 150°F or 250 psi @ 400°F	190°F 0 psi	See Catalog Section
Thermoplastic Holder with 304 Stainless Studs			PVC or Cast Iron		Aluminum		Cast Iron	Various	304 ss	
Available			Not Available				Special	Standard		
Not Available	Avail- able	Available	Available		Available		Standard	Not Available		
Special Applications			Watertight Industrial Duty		Industrial Duty		Watertight, Outdoor Heavy Duty	Special Applications		
Solid Rod Electrodes Cut to Desired Length			Adjustable		Adjustable		Adjustable	Fixed	Adjust- able	
Catalog Section 6012			Catalog Section 6012		Catalog Section 6012		Catalog Section 6012	Catalog Section 6013		Catalog Section 6013

B|W Controls

Electrode Holders/Electrodes

CAST PRESSURE-TIGHT ELECTRODE HOLDERS WITH EXTERNAL PIPE THREAD

B|W pressure-tight electrode holders are designed especially for applications which require a positive, leak-proof assembly. Such installations include boiler feed and condensate return systems, hydropneumatic tanks, and various types of chemical processing equipment, etc.

Whenever possible, these holders should be mounted in a vertical position through the top of the tank with the electrodes extending downward to the desired operating levels.

For applications requiring flange mounting B|W offers companion flanges in 2", 3", or 4" sizes made of cast iron or 304 SS. See Catalog Section 7014.

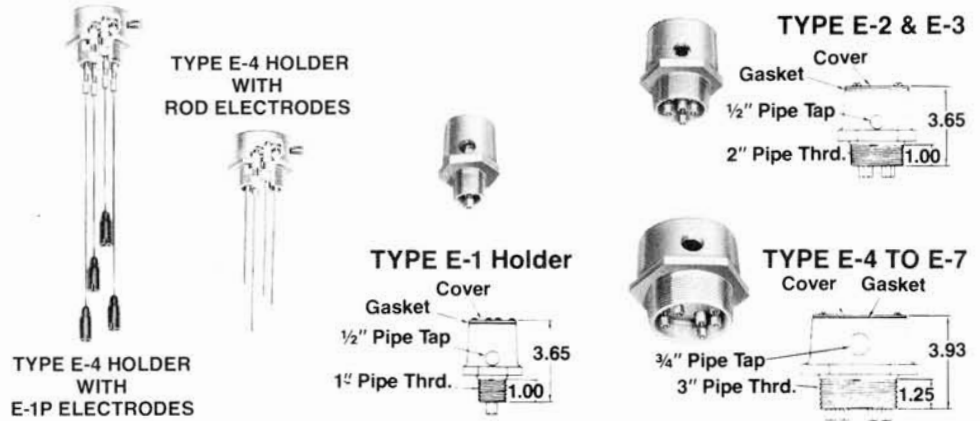

6012 — E1 — CI — EP1

CATALOG SECTION

HOLDER MATERIAL	
CI	Cast Iron
BR	Brass
SS	316 Stainless Steel

	No. of Electrodes	Mounting Thread	Shipping Weight
E1	1	1" Pipe	1.5 LB
E2	2	2" Pipe	3.0 LB
E3	3	2" Pipe	3.0 LB
E4	4	3" Pipe	5.0 LB
E5	5	3" Pipe	5.0 LB
E6	6	3" Pipe	6.0 LB
E7	7	3" Pipe	6.0 LB

NOTE — Price of electrode holder includes a standard electrode plug as indicated in the chart to the right.

CROSS REFERENCE TO OLD B|W PART NUMBERS

HOLDER TYPE	NUMBER OF ELECTRODES	MATERIALS AND PART NUMBERS		
		BRASS	CAST IRON	316 STAINLESS
E-1	1	12-048000	12-048100	12-048200
E-2	2	12-048400	12-048500	12-048600
E-3	3	12-048800	12-048900	12-049000
E-4	4	12-049200	12-049300	12-049400
E-5	5	12-049600	12-049700	12-049800
E-6	6	12-050000	12-050100	12-050200
E-7	7	12-050400	12-050500	12-050600

ELECTRODE PLUGS FOR CAST IRON & BRASS HOLDERS	
EP1	Furnished as standard equipment. Suitable for most applications. Up to 250 psi at 212°F (100°C). Up to 700°F (371°C) at 100 psi.
EP2	Recommended for saturated steam applications. Up to 250 psi at 400°F (204°C). Up to 550°F (288°C) at 200 psi.
EP3	Recommended for low pressure applications that are subject to some vibration or shock. Also for long electrode rods.
EP4	Used only for non pressure applications and only for wire suspension electrodes where the standard plug and wire connector arrangement is not suitable.
X	Holder furnished without electrode plugs but with the specified number of 3/8-18 Dryseal pipe thread holes for the plugs.

ELECTRODE PLUGS FOR 316 SS HOLDERS	
EP2	Furnished as standard equipment. Suitable for many corrosive applications, and for saturated steam up to 400 psi and 445°F (230°C).
EP3	Recommended for low pressure applications that are subject to some vibration or shock. Also for long electrode rods.
X	Holder furnished without electrode plugs but with the specified number of 3/8-18 Dryseal pipe thread holes for the plugs.

Ametek offers a wide selection of BIW electrode plugs for mounting electrodes in tanks and vessels. They are designed to meet a variety of environmental conditions to provide a strong mechanical mounting and to insulate the electrode from the tank structure; they also have a secure method to make the electrode lead wire connection to the BIW control relay. Details of a typical pressure tight electrode plug are shown in the diagram at the right. The central rod is sealed to the inside of the ceramic insulator glass, and the stainless steel bushing is sealed to the outside of the insulator with copper and/or Teflon® gaskets.

Electrode plugs are included in the Type E electrode holders. Also, these plugs are often used on OEM applications to provide reliable and inexpensive individual mounting of electrodes in special situations.

Other types of electrode plug and electrode assemblies are described in this Section. Should none of our standard items be suitable, special electrodes can be made to order to meet specific operating and/or installation conditions.

ELECTRODE PLUGS

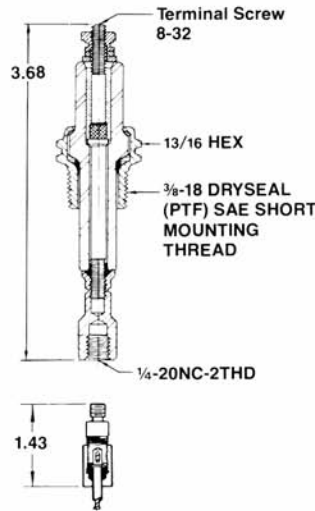

SOLID ROD ELECTRODES

Type A rod is used for short electrodes and is available in a variety of corrosion-resisting materials.

WIRE SUSPENSION ELECTRODES

These electrodes are used for long lengths and where space prevents use of rod electrodes.

WIRE CONNECTOR
One required with each wire suspension electrode.

6012-EP2

CATALOG SECTION

These plugs can be installed in Type E Holders.

	OLD PART NUMBER	MOUNTING THREAD	CONSTRUCTION MATERIALS	PRESSURE/TEMPERATURE RATINGS
EP1	04-126400	3/8-18 Dryseal (PTF) SAE Short Pipe Thread	Shell-303SS Insulator-Ceramic Seal-Glass & Copper	2000 psi Up to 200°F (93°C) 700°F (371°C) Up to 100 psi
EP2	04-141300	3/8-18 Dryseal (PTF) SAE Short Pipe Thread	Shell-303SS Insulator-Ceramic Seal-Glass & Teflon®	2000 psi Up to 200°F (93°C) 550°F (288°C) Up to 200 psi Saturated Steam Up to 450 psi
EP3	04-149600	3/8-18 Dryseal (PTF) SAE Short Pipe Thread	Shell-303SS Insulator-Teflon® Seal-Teflon®	500 psi Up to 270°F (132°C) 300°F (149°C) Up to 250 psi Saturated Steam Up to 125 psi
EP4	12-066400	3/8-18 NPT Pipe Thread	Shell-Aluminum Cord Grip with Neoprene Packing	For Nonpressure Use Up to 190°F (88°C) (Only for wire suspension electrodes)

6012-EP5

CATALOG SECTION

This plug is for separate mounting only.

	OLD PART NUMBER	MOUNTING THREAD	CONSTRUCTION MATERIALS	PRESSURE/TEMPERATURE RATINGS
EP5	04-134900	5/8-24 NEF-3 Machine Thread	Shell-303SS Insulator-Ceramic Seal-Glass & Copper	2000 psi Up to 200°F (93°C) 700°F (371°C) Up to 100 psi

ELECTRODE PLUG COVER

Catalog Number	Old Part No.	Description
6012-PC	04-129000	Designed to insulate and protect the electrode lead connection. Made of neoprene and fits all standard plugs.



B|W Controls

Electrode Holders/Electrodes

FLANGED CAST IRON ELECTRODE HOLDERS

These flanged holders are for use with B|W wire suspension electrodes in non-pressure applications such as elevated tanks, water reservoirs, underground storage tanks, sewage wet wells and other installations requiring relatively long electrode lengths. They are of rugged construction made of cast iron with baked aluminum paint finish to be very durable for many years of outdoor exposure. Available in 3", 4" and 6" sizes which fit the 125 Lb. CI and 150 Lb. Steel mounting flange specifications.

These holders have a removable inner plate provided with a grommet for each wire suspension electrode. The grommets are sized to give a snug vapor tight fit with B|W Type SW electrode suspension wire, and the electrodes are secured by means of a simple overhand knot in the suspension wire as shown in the picture below. The mounting plate with electrodes attached can be easily removed through the top of the electrode holder to facilitate cleaning and adjustment of the electrodes when required.



TYPE E-55-3 HOLDER
3 inch Cast Iron 125 lb.
Mounting With Aluminum Paint
Finish For 1 to 7 Wire
Suspension Electrodes.

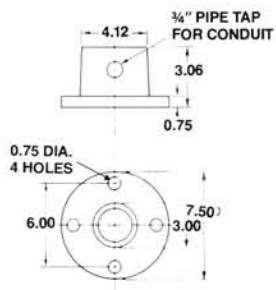

TYPE E-55-6 HOLDER
6 inch Cast Iron 125 lb. Mounting
With Aluminum Paint Finish For 1
to 13 Wire Suspension Electrodes.

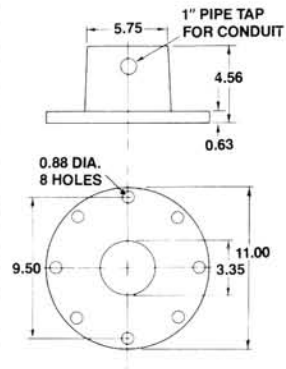

TYPE E-55-4 HOLDER
4 inch Cast Iron 125 lb. Mounting
With Aluminum Paint Finish For 1 to
13 Wire Suspension Electrodes.

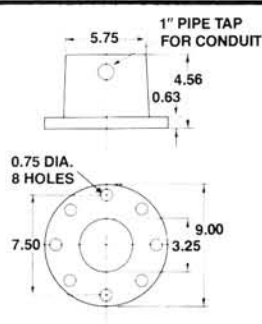

6012 — E553

CATALOG SECTION

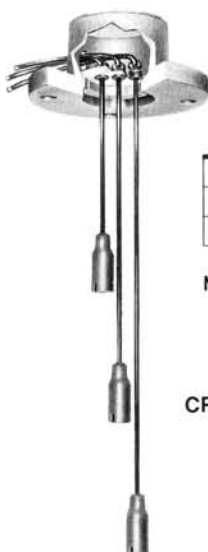

	Mounting Provision	Number Of Electrodes	Shipping Weight
E553	3 in. Flange	1-7	14 lb.
E554	4 in. Flange	1-13	24 lb.
E556	6 in. Flange	1-13	30 lb.

NOTE: These holders are not available for use with solid rod electrodes. For applications requiring rod electrodes with flange mounting, use a Type E holder and a separate threaded mounting flange.

CROSS REFERENCE TO OLD BIW PART NUMBERS

Holder Type	Old Part Number
E-55-3	12-054400
E-55-4	12-056400
E-55-6	12-056700

5E

These electrode holders are for non pressure applications only

Number Of Openings Provided For Wire Suspension Electrodes	
1E	1
2E	2
3E	3
4E	4
5E	5
6E	6
7E	7
8E	8
9E	9
10E	10
11E	11
12E	12
13E	13

NOTE: The required wire suspension electrodes must be ordered as separate items.

These versatile corrosion resistant electrode holders are made of unplasticized PVC for use on industrial and chemical applications such as acid storage tanks, plating tanks and liquid waste treatment systems. They are suitable for ambient temperatures up to 180°F (82°C). They include a watertight PVC cover or a junction box. Types are available for mounting on standard 1", 2", 3" or 4" flanges. The Type FR56 is intended for mounting on the corner of an open flanged rim tank, and only requires minimum space in the tank.

Models are available for use with either solid rod or wire suspension electrodes which must be ordered as separate items for field assembly at time of installation.

Solid rod electrodes extend thru the bottom of the holder and are tightened against a shoulder which provides a vapor tight seal for up to 10 psi. Rods should be insulated for lengths greater than 30 in.

Wire suspension electrodes are recommended for lengths over 6 feet. The BIW Type SW suspension wire is brought into the holder through a clearance hole and is secured by a knot as illustrated below. The Type 13-064700 electrodes are available in the same selection of materials as the solid rods and must be used for corrosive liquids.

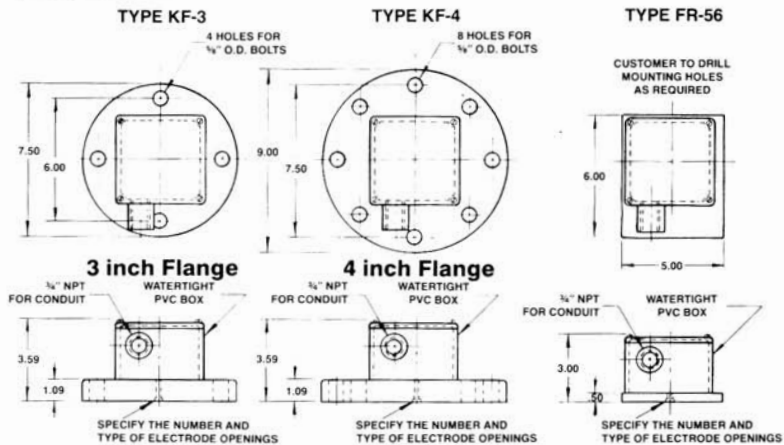
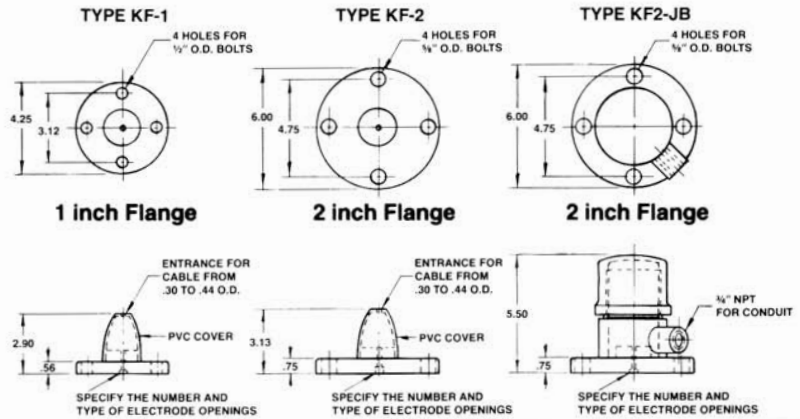

6012 CATALOG SECTION

KF3-4 RC

ELECTRODE OPENINGS
Specify Number of Openings Required.

	MAX. NO. OF ELECTRODES	SHIPPING WEIGHT
KF1	*1 or 2	1.0 LB
KF2	4	2.0 LB
KF2Jb	4	2.5 LB
KF3	7	3.0 LB
KF4	7	4.0 LB
FR56	5	1.5 LB

*One bare rod or wire suspension electrode, or two insulated rods.

Type of Electrode To Be Used

RC	Type C Solid Rod For Type KF Holders
RD	Type D Solid Rod For Type FR Holders
WS	Wire Suspension Electrodes For Type KF or FR Holders

NOTE: The required electrodes must be ordered as separate items for field assembly to holder.

CROSS REFERENCE TO OLD PART NUMBERS

HOLDER TYPE	Bare Rods	Insulated Rods	Wire Suspension
KF1	12-066300	12-066100	12-083400
KF2	12-063800	12-062400	12-077800
KF2Jb	12-083500	12-082900	12-083100
KF3	12-065200	12-070700	12-077300
KF4	12-071100	12-071500	12-081700
FR56	12-080500	12-080300	12-083300

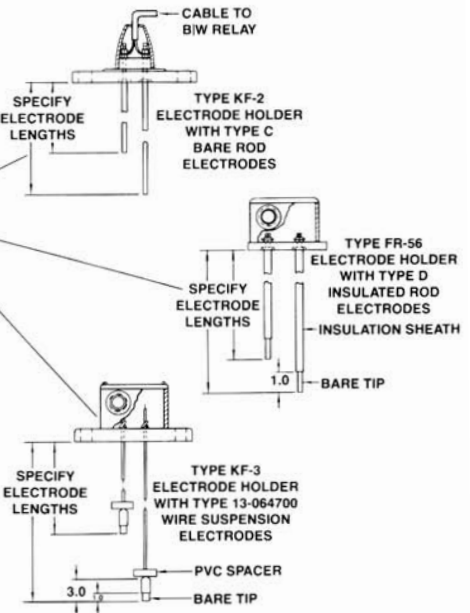

B|W Controls

Electrode Holders/Electrodes

MOLDED ELECTRODE HOLDERS



Type AE-2 with rod electrodes

Type CE-2 & CE-3 Holders — These small holders are primarily for use in original equipment applications where available space is limited and where desired level control can be obtained with two or three short solid rod electrodes. They are furnished with a flexible PVC water-tight cover to protect lead wire junctions.

A choice of two thermoplastic materials is available with ratings as shown below. Pressure seal is accomplished with a Buna N gasket included with each holder. They have 303SS studs with 6-32 male thread for electrode connections.

HOLDER MATERIAL	MAXIMUM RATINGS
Butyrate	200 psi @ 100°F (38°C) 160°F (71°C) @ 0 psi
Nylon	200 psi @ 200°F (93°C) 350°F (177°C) @ 0 psi



Type CE-2 Holder
For 2 Rod Electrodes
1"-14 Straight Machine Thread



Type CE-3 Holder
For 3 Rod Electrodes
1"-14 Straight Machine Thread

CATALOG NUMBER
6012 — CE2B

	Holder Material	Old Part Number
CE2B	Butyrate	12-053600
CE2N	Nylon	12-082500

CATALOG NUMBER
6012 — CE3B

	Holder Material	Old Part Number
CE3B	Butyrate	12-073500
CE3N	Nylon	12-082700

NOTE: The required Type 6B rod electrodes must be ordered as separate items. Maximum recommended bare rod length is 12 inches. Not available for wire suspension electrodes.

Type AE-2 Holders — Molded of ABS corrosion-resistant thermoplastic material, these holders are ideal for use in applications involving control of many corrosive liquids. Designed to permit the use of either two solid rod or two wire suspension electrodes, they are supplied with flexible PVC water-tight covers to protect the lead wire junctions.

They have 303SS couplings with 1/4-20 female thread for electrode connections.

MAXIMUM RATINGS
250 psi @ 100°F (38°C) 180°F (82°C) @ 0 psi



TYPE AE-2 HOLDER

For 2 Rod or Wire
Suspension Electrodes
2" NPT Pipe Thread Mounting

Catalog No. 6012-AE2
Old Part No. 12-034500

NOTE: The required electrodes must be ordered as separate items, see Catalog Section 6013 for information.

Rod Electrodes — Type A rods are used.

Wire Suspension Electrodes — A wire connector is required for each wire suspension electrode.

CONDUIT ELECTRODE HOLDERS



Designed for use with B|W wire suspension electrodes, these versatile low-cost holders are recommended for underground drainage sumps, septic dosing tanks, open sumps and similar applications. Available in cadmium plated cast iron for general purpose applications, or rigid polyvinyl chloride for corrosive situations.

These holders are mounted by attaching to a length of standard conduit extending over the liquid being controlled. They have grommets for each wire suspension electrode, and come in two sizes to accommodate up to eight electrodes.

CATALOG NUMBER
6012 — C4I

	No. of Electrodes	Holder Material	Conduit Size	Connection Type	Old Part Number
C4I	1-4	Cast Iron	1/2" NPT	Threaded	12-056900
C4P	1-4	PVC	1/2" PVC	Cement	12-065400
C8I	1-8	Cast Iron	1" NPT	Threaded	12-081800
C8P	1-8	PVC	1" PVC	Cement	12-081900

NOTE: The required wire suspension electrodes must be ordered as separate items.

CORD GRIP ELECTRODE HOLDERS



Type CG1 with E-IP Electrode



Type CG2 with E-IS Electrodes

B|W cord grip electrode holders provide a simple, low-cost means of sealing lead wire openings against leakage of gases and liquids in non-pressure applications requiring use of wire suspension electrodes. These include submersible pump installations with low level cutoff control, underground water storage tanks, covered sumps, and sewage pumping stations.

Made of aluminum machined for 1/2" pipe thread mounting, they are furnished with compressible Neoprene packing to support either one or two wire suspension electrodes.

CATALOG NUMBER
6012 — CG1

	No. of Electrodes	Holder Material	Mounting Thread	Old Part Number
CG1	1	Aluminum	1/2" NPT	12-055900
CG2	2	Aluminum	1/2" NPT	12-056000

NOTE: The required wire suspension electrodes must be ordered as separate items.

STANDARD ASSEMBLY

BIW ice-free electrode units are designed to provide positive, reliable pump control in areas where severe winter temperatures cause icing conditions which would normally interfere with or prevent proper pump operation.

The assembly consists of a Type 6012-E554 cast iron flanged electrode holder threaded onto a 3" steel pipe and details are illustrated at the right. The thermostat is factory set to close at 32°F (0°C), and the heater will keep the water inside the 3" pipe free of ice even when heavy ice forms on the surface of the water surrounding the ice-free electrode assembly. The 4" pipe nipple with companion flange is provided to mount the unit. The nipple must be attached vertically to the tank top, and the rest of the assembly is then lowered and bolted into place.

When designing the control system, provisions must be made to cut-off the power to the immersion heater whenever the water level falls below the lowest electrode because the heater will burn out if it is energized when exposed to air.

A single pump, pump up system requires a BIW Type 1500-G relay with the NC contact controlling the pump, and the NO contact providing cut-off for the heater. See Catalog Sections 8040 and 8044 for information on standard and custom control panels.

TYPE IFW

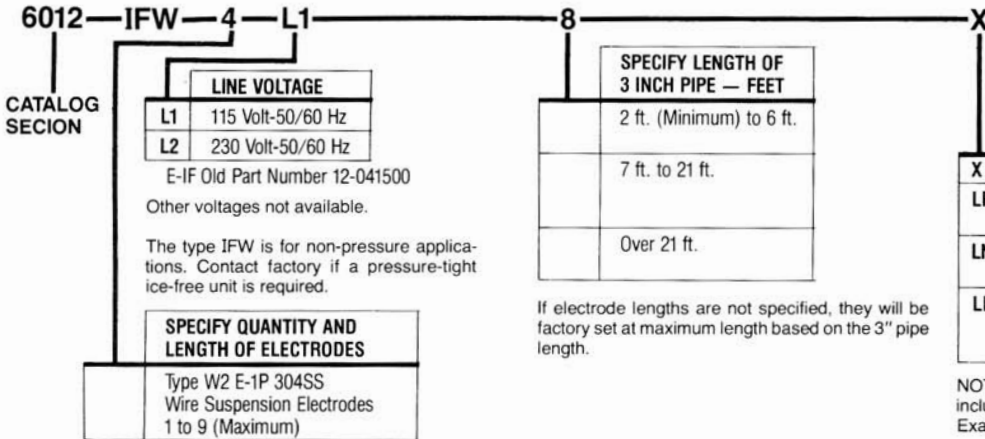
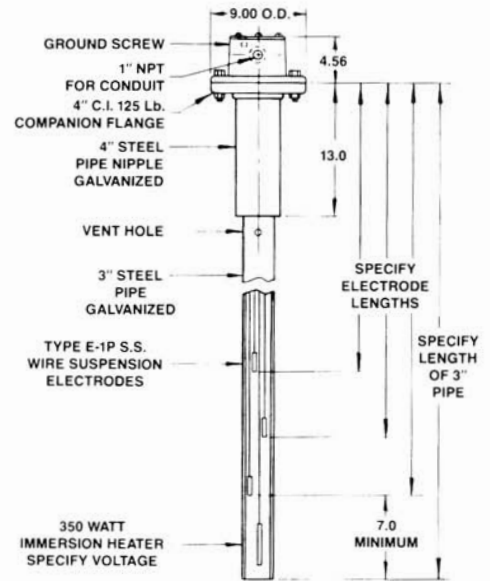

NOTE — if more than one item is to be omitted, include the symbol for each item deducted.
Example — LP-LN-LF

TYPE IFR

SHALLOW TANK ASSEMBLY

Some applications such as cooling tower basins require short electrode lengths, and as shown at the left, the Type IFR will mount directly on a tank top, or on a bracket inside the basin.

These assemblies have electrode plug and stainless PVC insulated solid rod electrodes. The 115 VAC heater is designed for operation in air and low level cut-off provision should not be provided.

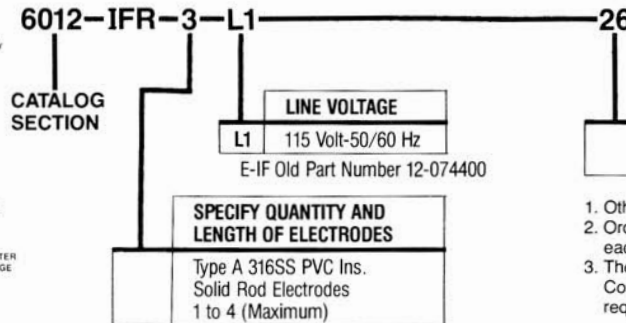
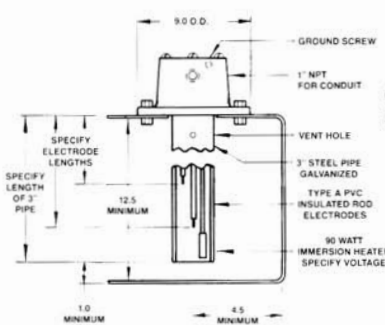

- Other voltages not available.
- Order cannot be processed without length of each electrode and length of the 3 inch pipe.
- The Type IFR is for non-pressure applications. Contact factory if a pressure-tight ice-free unit is required.

B|W Controls

Electrode Holders/Electrodes

WIRE SUSPENSION ELECTRODES

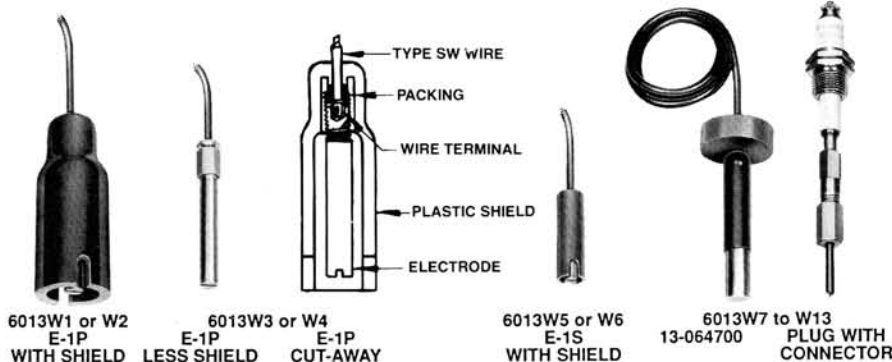

Wire suspension electrodes are designed for use in applications requiring long lengths, or where limited head room prevents installation of solid rod electrodes. They can be used with all holders except Type CE-2 & 3. Electrode Types E-1P and E-1S are for use in water and non-corrosive liquids. Type 13-064700 is designed for corrosive liquids and is available with a variety of rod materials. Types E-1P and E-1S electrodes with molded plastic shields can be used at temperatures up to 150°F and other electrodes up to 190°F.

Type E-1P-Shielded: This electrode is approximately 4" long and assembled in a molded plastic insulating shield 1 7/16" in diameter. Designed for general purpose use, it is ideal for elevated tanks, sewage pumping stations, and deep well installations.

Type E-1P — Less Shield: This electrode is intended for applications where space prevents the use of other electrodes and where vertical spacing between electrodes is 4" or more.

Type E-1S-Shielded: A 2" long electrode assembled in a molded plastic shield 9/16" in diameter. Ideal for use in submersible pump installations and other applications where little clearance is provided for installation.

Type 13-064700: This electrode is intended for corrosive liquids. It is 3" long made from a 1/2" diameter rod and available in any of the materials listed below. The type SW wire is attached at the factory and the connection is completely sealed with PVC and bonded to the insulation of the SW wire.

WIRE CONNECTOR: This adapter is necessary to attach the Type SW suspension wire to the 1/4-20 female electrode holder connections. One is required for each wire suspension electrode used with electrode plugs, and Type E and Type AE-2 holders.

CATALOG NUMBER
6013—C—BR



Material	
Brass Old No. 12-038400	BR
303 SS Old No. 12-043800	SS

Type SW Suspension Wire: Designed to provide maximum strength and insulation, Type SW wire should always be used with B|W wire suspension electrodes to assure that a water-tight seal is accomplished by the packing in the electrode. The wire is single conductor 18 gauge, 41 strand copper with 4/64" vinyl insulation.

CATALOG NUMBER
6013—SW—10



Specify Length In Feet	
Old No. 01-130500	

These electrodes are field assembled and the required amount of Type SW wire must be ordered as a separate item. See above.

NOTE — When wire suspension electrodes are to be used with electrode plugs, or Type E or Type AE-2 electrode holders, wire connectors must also be ordered for each electrode. See above.

6013—W1

CATALOG SECTION

	ELECTRODE TYPE	ELECTRODE MATERIAL	OLD PART NO.
W1	E-1P With Shield	Brass	13-020600
W2	E-1P With Shield	303 Stainless	13-020700
W3	E-1P Less Shield	Brass	13-052700
W4	E-1P Less Shield	303 Stainless	13-052600
W5	E-1S With Shield	Brass	13-022000
W6	E-1S With Shield	303 Stainless	13-024300

6013—W7

CATALOG SECTION

	ELECTRODE TYPE	ELECTRODE MATERIAL	OLD PART NO.
W7	13-064700 With SW Wire	316 Stainless	13-064702
W8	13-064700 With SW Wire	Monel	13-064703
W9	13-064700 With SW Wire	Nickel	13-064704
W10	13-064700 With SW Wire	Carpenter 20	13-064705
W11	13-064700 With SW Wire	Hastelloy B	13-064707
W12	13-064700 With SW Wire	Hastelloy C	13-064706
W13	13-064700 With SW Wire	Titanium	13-064709

10

Type SW Wire Length In Feet	
--------------------------------	--

These electrodes come complete with the Type SW wire permanently attached to the electrode. Lengths must be specified when ordering.

SOLID ROD ELECTRODES

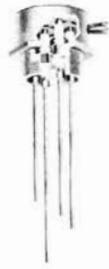

6012E4
HOLDER



6013
ELECTRODE
PLUG



AE-2
HOLDER



6012-CE2
HOLDER
TYPE B
RODS

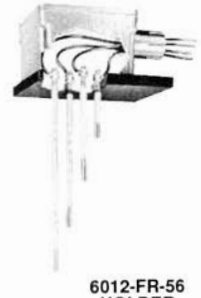

6012-FR-56
HOLDER
TYPE D
RODS

ELECTRODE MATERIAL SELECTION

The chart below suggests electrode material for some typical liquids. Electrode corrosion is difficult to predict because the rate of corrosion is effected by many factors such as: concentration, temperature and impurities. Therefore, this information should be used as a general guide, and the final choice should be determined from actual application conditions based on previous experience and knowledge.

ELECTRODE MATERIAL	TYPICAL LIQUID TO BE CONTROLLED
Brass	Soft Water, Condensate
316 SS	Water, Sewage, Beer, Alcohol, Food Products, Chemicals, Many Mild Acids
Monel	Acetic Acid, Sea Water
Nickel	Boric Acid, Calcium Hydroxide
Carpenter 20	Sulphuric Acid, Alum Solutions
Hastelloy B	Hydrochloric Acid
Hastelloy C	Hydrofluoric Acid
Titanium	Phosphoric Acid, Brine Ferric Chloride, Hot Nitric Acid
Carbon Tip	Hydrochloric Acid Carbonated Water

Contact Factory for specific recommendations.

TYPE A RODS

Solid rod electrodes are generally used where relatively short lengths of 6 feet or less are required. Care should be exercised when specifying lengths over 6 feet. Longer rods and those installed horizontally should be insulated. After cutting insulated rods, strip about 1 inch of insulation off lower end to expose the bare rod.

TYPE A electrode rods are 1/4" diameter and have 1/4-20 thread for use with electrode plugs, and Type E and Type AE-2 electrode holders. A boot made of the sheath material is furnished to protect and insulate the lower side of the electrode plug.

TYPE B electrode rods are 1/4" diameter and are tapped 6-32 for use only on Type CE-2 and CE-3 holders. Lengths over 12 inch should be insulated and lengths over 30 inch not recommended.

TYPE C electrode rods are 1/4" diameter and have the upper end machined with a shoulder and 10-24 thread to assemble into Type KF holders.

TYPE D electrode rods are 1/4" diameter are similar to Type C except the upper end is machined to a length that fits only Type FR holders.

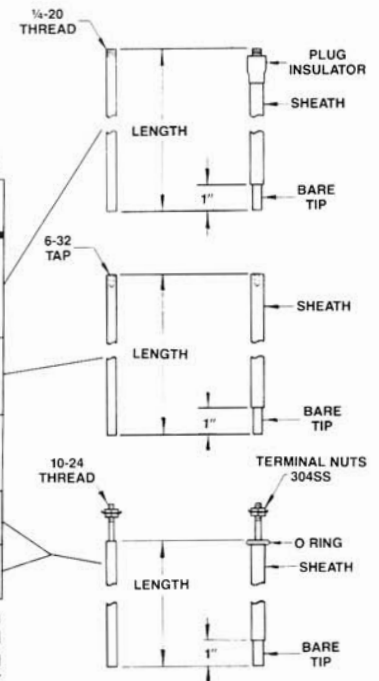
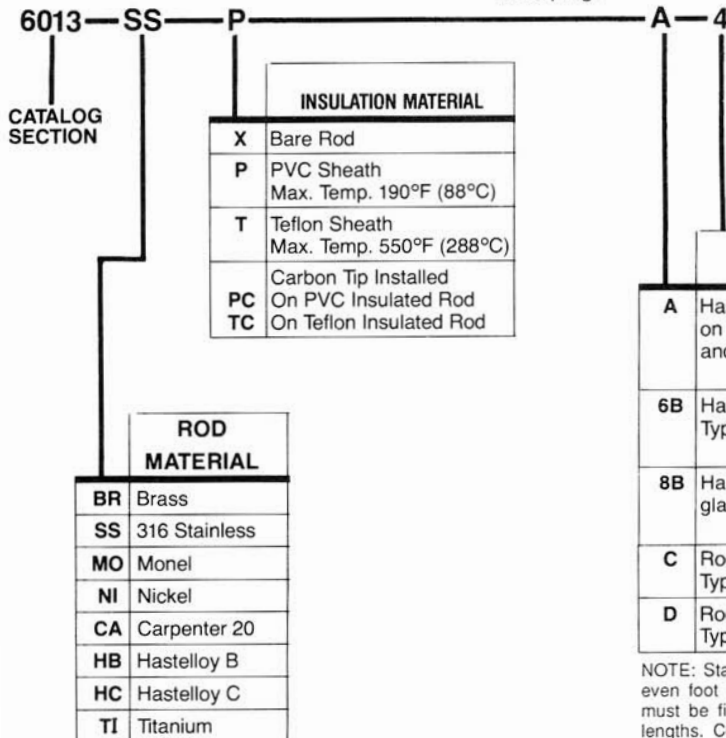

NOTE: Standard stock rods are furnished in even foot increments up to 10 ft. long, and must be field cut for intermediate operating lengths. Contact Factory for pricing on other lengths and materials.

B|W Controls

Electrode Holders/Electrodes



GLAND PLUG AND ROD ASSEMBLY

The packing gland construction of these units provides additional strength for electrodes on applications where there is vibration, shock or side thrust against the electrode. Installations include detecting the presence or absence of fluids in shipboard bilge discharge lines, or coal slurry pipelines.

The lower plug body is available in most of the same materials as the electrode rods so that these assemblies are quite suitable for many corrosive conditions. With teflon insulated rods they are rated for use up to 250 psi and 400°F (204°C).

These gland plug electrode assemblies can also be used in the Type E electrode holders instead of the standard electrode plugs.

The gland plug assemblies are separately ordered for field assembly.

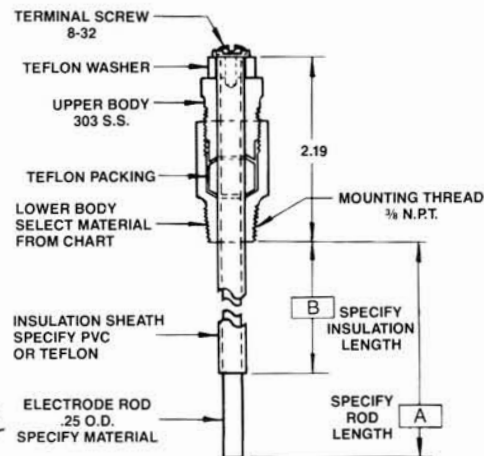

CATALOG NUMBER
6013 — GP — CA

	LOWER BODY MATERIAL	OLD PART NUMBER
303	303 Stainless	12-065800/12-065900
316	316 Stainless	12-074600
MO	Monel	12-075800
NI	Nickel	12-079600
CA	Carpenter 20	12-074700
TI	Titanium	12-078000

SS — P — 8B — 4

Electrode Rod Details
See Previous Page

A dimension is electrode length
B dimension is insulation length

ADJUSTABLE GLAND ELECTRODE ASSEMBLY

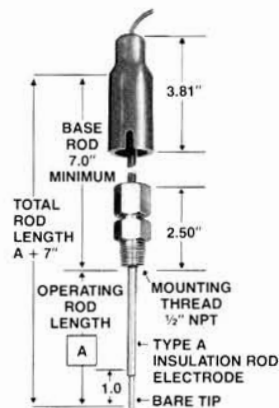

B|W adjustable gland electrode holders are designed for use in applications that require occasional changing of the high or low level control settings. Typical installations include conveyor feed, liquid proportioning, and container filling machines.

Made of 303 stainless steel with positive pressure-tight 1/2" pipe thread mounting plus Teflon or Neoprene insulation and packing. These holders are used with insulated solid rod electrodes of any desired length. To adjust level settings, simply loosen the top of the holder and slide the electrode up or down to required depth. Electrodes must be insulated over the full range of adjustability.

CATALOG NUMBER
6013 — AGP — 15 — SS-P

Specify rod material and insulation material
The A dimension operating electrode rod length must be furnished with order.
NOTE See Catalog Section 6013 page 13 for selection of rod materials. ADD price of insulated rod to total.
Type SW Wire Length In Feet
DESCRIPTION AGP Adjustable Gland & Rod Assy. Old Part No. 12-057000

RUGGEDIZED ELECTRODE ASSEMBLY

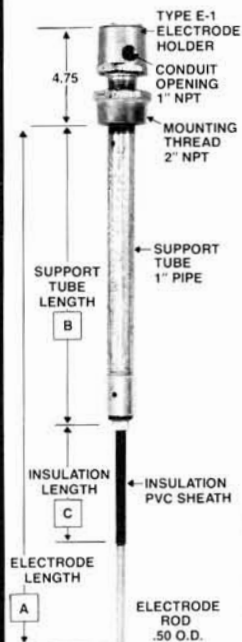

These Type REA electrode assemblies are very strong for use on heavy solutions, particularly when they are being agitated with a mixer. Applications include clay or starch solutions used for sizing in the manufacturing of paper products.

The Type E-1 holder provides water-tight protection for the electrode connection and is available in cast iron, brass or 316 S.S. The support tube which provides strength to prevent deflection of the 1/2" OD stainless rod is available in galvanized steel or other materials such as stainless steel.

CATALOG NUMBER
6013 — REA
Old Part No. 12-070600

When placing an order or requesting a quotation, specify the required lengths for dimensions A, B, & C, and the type of material for the holder and support tube.

SMALL BUSHING AND ROD ASSEMBLIES

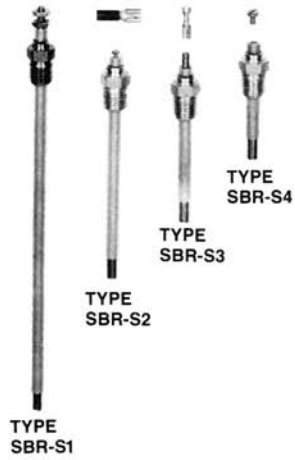

Ametek offers a variety of these small electrode assemblies to meet special OEM situations for single electrodes. The bushing has a 1/4" NPT pipe thread for pressure-tight mounting and is available in either cadmium plated steel or 316 S.S. The electrode rod is 1/4" O.D. and must be insulated for at least 1" below the bushing. The available PVC or teflon insulated rod materials are listed on page 35. There is a choice of four methods to connect the electrode lead wire.

CATALOG NUMBER
6013 — SBR — S1 — S

TYPE OF WIRE CONNECTION	
S1	Double Nut
S2	Push-On Spade
S3	Push-On Bayonet
S4	6-32 Screw

Minimum Order
25 pieces

For quotation advise, type of wire connection, bushing material, material and length of insulated rod.

CONCENTRIC ELECTRODE ASSEMBLIES

These assemblies are primarily for OEM applications requiring two short electrodes and where space is limited to install them. While developed for carbonator level control, they are suitable for any small tank for use up to 150 psi and 170°F (77°C). The mounting bushing is made of 316 S.S. with 1/2"-20 machine thread, and a nylon gasket is provided. The snap-on cord set has a three conductor type SJT cord which provides ground connection to the mounting bushing, as well as the two electrode leads.

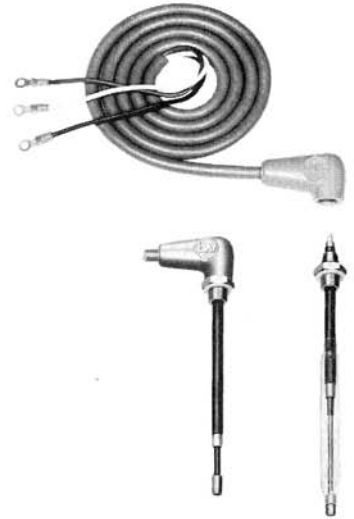

CATALOG NUMBER
6013 — CEA — S

Minimum Order
25 pieces

For a quotation advise the length of both electrodes, the length of the cord set, and the type of termination for the wire leads.

SPACERS FOR INSULATED ELECTRODE RODS

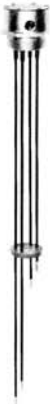

BIW rod spacers are used to stiffen long electrode rod assemblies in those situations where movement of the liquid would tend to deflect the rods. They must never be attached to bare electrode rods because liquid on the surface of the spacer could short between electrodes preventing proper operation of the BIW control relays.

The PVC spacers include heat shrinkable PVC sleeves for attaching them to PVC insulated rods. The teflon spacers have heat shrinkable teflon sleeves to secure them to teflon insulated rods.

CATALOG NUMBER
6013 — RS2 — P

SPACER DESCRIPTION	INSULATION MATERIAL	
	Number Of Rods	For Use With Holder Type
RS1	2	E-2
RS2	3	E-3
RS3	4 to 7	E-4 to E-7
RS4	2	KF-1
RS5	2 to 4	KF-2 or KF-2JB
RS6	2 to 7	KF-3 or KF-4
RS7	2 to 5	FR-56

INSULATION MATERIAL	
P	PVC
T	Teflon

NOTE
Contact factory for quote on special assemblies consisting of electrode holders with insulated electrode rods and spacers attached.

MOISTURE SENSOR

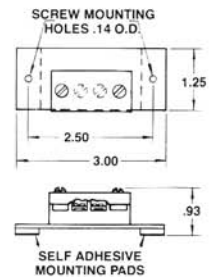

The Type MSA moisture sensor is a compact low cost device used to detect water leakage into areas such as computer room subfloors, communication vaults, below grade ductwork, floors in basements, storage areas or equipment rooms. It is easily attached to a floor or wall surface by the self adhesive strips or the mounting screws provided.

While designed as a sensor for the Series 41 Alarm Panel described in Catalog Section 8041, they can also be used to operate any of the BIW control relays. The relay or alarm is actuated when moisture bridges adjacent printed circuit paths on the underside of the sensor.

CATALOG NUMBER
6013-MSA-1
Old Part No. 13-074400