

Technical Manual

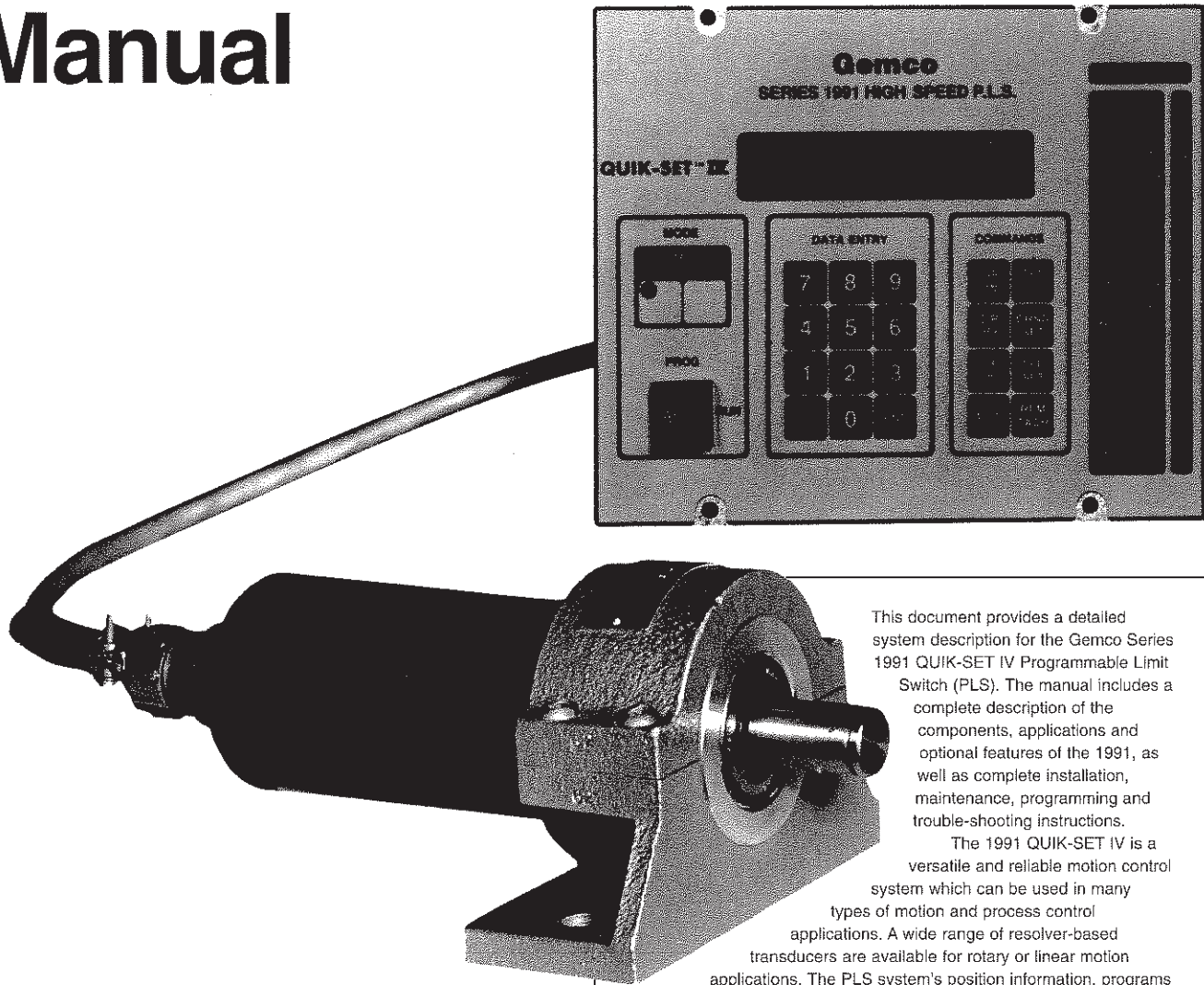

This document provides a detailed system description for the Gemco Series 1991 QUIK-SET IV Programmable Limit Switch (PLS). The manual includes a complete description of the components, applications and optional features of the 1991, as well as complete installation, maintenance, programming and trouble-shooting instructions.

The 1991 QUIK-SET IV is a versatile and reliable motion control system which can be used in many types of motion and process control applications. A wide range of resolver-based transducers are available for rotary or linear motion applications. The PLS system's position information, programs and set point memory are non-volatile, making it as reliable as fixed limit or proximity switches, but far more flexible.

The remainder of this manual will describe in detail all the advanced features of the 1991, which include: up to 48 output channels; 8 separate programs which are keypad selectable; run up/speed compensation circuits with opening or closing dwells; and virtually limitless combinations of options and features.

TABLE OF CONTENTS

I.	INTRODUCTION/DESCRIPTION		V.	ADVANCED FEATURES AND OPTIONS	
	Problem Solving Procedures	3		Programmer Options	23
	Introduction	4		Linear Speed Compensation	23
	Product Description	4		Multi-Program	23
	Product Component Diagram	4		Analog Output	24
	Product Component Description	5		Binary Output	24-25
	Resolver with Keypad and CPU Module ...	5		Reset to Preset	25
				Remote Serial Display	25
				RS-2332/485 Transceiver	25
II.	INSTALLATION		VI.	TROUBLESHOOTING	
	Introduction	6		Introduction	26
	Mechanical Installation	6		Preliminary Checks	26
	Mounting Diagrams	6		Input Operation	26-27
	CPU Module Only	6		Output Operation	27-28
	Display and CPU Module	7		Relay Output Modules	28-29
	Display Module Only	7		Output Relays	29
	P.C. Interface Output Module	8		Electrical Noise	29-30
	Solid State Output Module	8		Troubleshooting Symptom Guide	31-32
	Mechanical Output Module	9			
	Electrical Installation	9			
	Wiring Instructions	9			
	Wiring Diagram Reference Chart	10			
	General Wiring Diagram	11-12			
	Low-Power Outputs Diagram	13			
	High-Power Relay Output Diagram	14			
	Optional Analog Output Diagram	15			
	Auxiliary Digital Output Diagram	16			
	Auxiliary 32 & 48 Limit Switch - Output Wiring Diagram	17			
	Single-Turn Resolver Diagram	18			
III.	SPECIFICATIONS				
	Programmer Specifications	19			
	CPU Module Output Types	19			
	Auxiliary Outputs	19			
	High Power Output Modules	19			
IV.	PROGRAMMING				
	Keyboard Functions	20			
	Scale Factor	20-21			
	Decimal Point	21			
	Offset Value	21			
	Set Points	21-22			
	Motion Detection	22			
	Minimum Speed Disable	22			

PROBLEM SOLVING PROCEDURES

If you are having trouble with your 1991 PLS system, follow this step-by-step procedure for the quickest correction.

First, always check system connections at the transducer, programmer, and output module to ensure that all connectors and wires are secured. A slight tug on each wire at the programmer connectors is also recommended. Verify that all wiring to the programmer matches the programmer data plate.

The next step is to check the input power to the system. Input voltage should be 115 VAC or 230 VAC $\pm 10\%$ depending on the voltage rating of the module. Also verify that the line fuse has not blown.

It is important to check the DC operating voltages at the programmer CPU module S2 connector.

Finally, check the transducer excitation on the programmer S1 connector. A shorted resolver wiring may cause a failure in the programmer. For more information concerning these problems, refer to the troubleshooting section on pages 26-32.

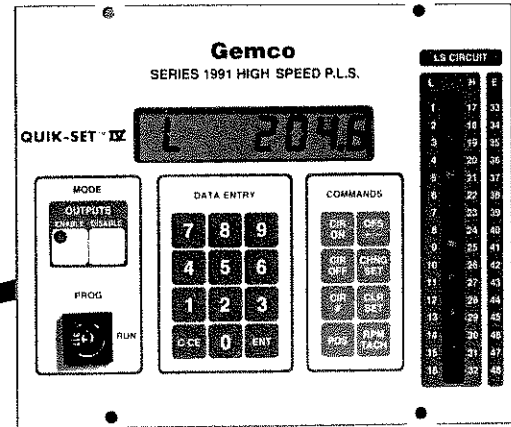
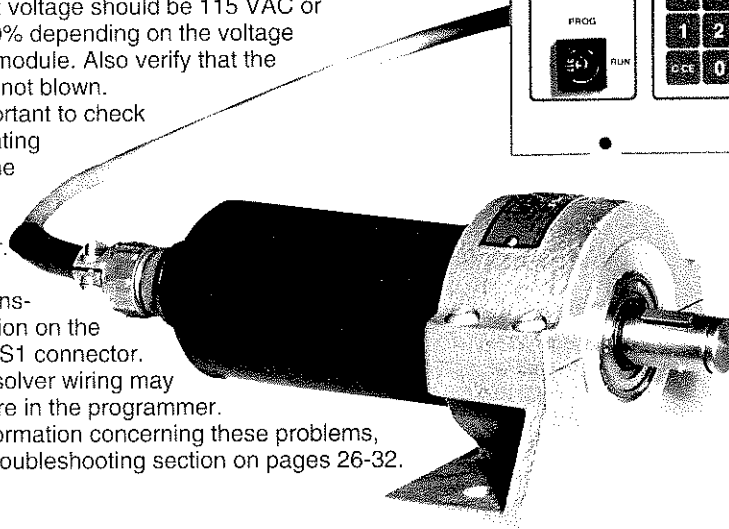

For technical information, service and application engineering assistance, or additional copies of this documentation, contact:

Gemco
1080 North Crooks Road
Clawson, Michigan 48017-1097

Telephone: (810) 435-0700
Facsimile: (810) 435-8120

If you are having problems with the 1991 PLS and have been unable to solve them with the troubleshooting procedures explained on pages 26-33, call a Gemco Customer Service Engineer.

For best service, make sure you have the following information before you call:

- system catalog number
- serial number of the unit
- your order number (if available)
- application information
- detailed description of the problem including self-diagnostic test results
- history of your product and previous problems with it.

I.

INTRODUCTION / DESCRIPTION

PRODUCT COMPONENT DESCRIPTION

Resolver transducers are highly accurate and reliable. They provide an absolute analog signal which varies as a function of the angular rotation of the input shaft. The two phase stator and single phase rotor of the resolver provide a ratiometric output that does not vary with changes in rotor voltage, frequency or temperature.

Brushless resolvers are available in heavy duty NEMA 4 enclosures with plug-in connectors. Input shafts are available in 3/4 inch, 5/8 inch and 3/8 inch sizes along with a wide range of foot mount, flange mount and face mount packages that duplicate most competitive resolver and encoder packages.

Single-turn resolvers are accurate to within 6 arc minutes. The PLS offers 12 bit resolution as standard with special 14 bit systems available upon consultation with the factory.

The 1991 programmer includes the following basic features: 16 circuits, each of which will accept multiple set points; non-volatile, non-battery backed memory; programming keypad; key locked program switch; programmable decimal point; programmable scale factor; full-scale offset; position or RPM display; NEMA 12 faceplate; motion detection; enable/disable switch; programming through zero; choice of output types; multiprogram storage and speed compensation software; and 12 bit resolution.

The programmer display module is an all metal NEMA 12 faceplate that can be permanently mounted through a panel cut out. The faceplate contains an eight digit LCD display, enable/disable keypad, key-locked program switch, data entry and command keys, and output status lights. In addition to the faceplate, the keypad module also contains an LCD display board, an LED board, a metal backplate, a cable for connection to the CPU module, and two keys for the PROG/RUN selector switch.

The programmer CPU module is an all-metal assembly which can be mounted separately or can be screwed to the back of the display module to save mounting space inside the enclosure. This module consists of an I/O and transducer interface board, CPU board, expansion board (if required), and from 2 to 4 edge connector terminal strips.

The output module provides a high-power mechanical relay, P.C. interface, solid-state triac, or open collector outputs which can drive the machine control devices or a programmable controller. The output directly from the CPU module is normally capable of driving a programmable controller input card directly and the output module may not be necessary.

Resolver with Keypad and CPU Module

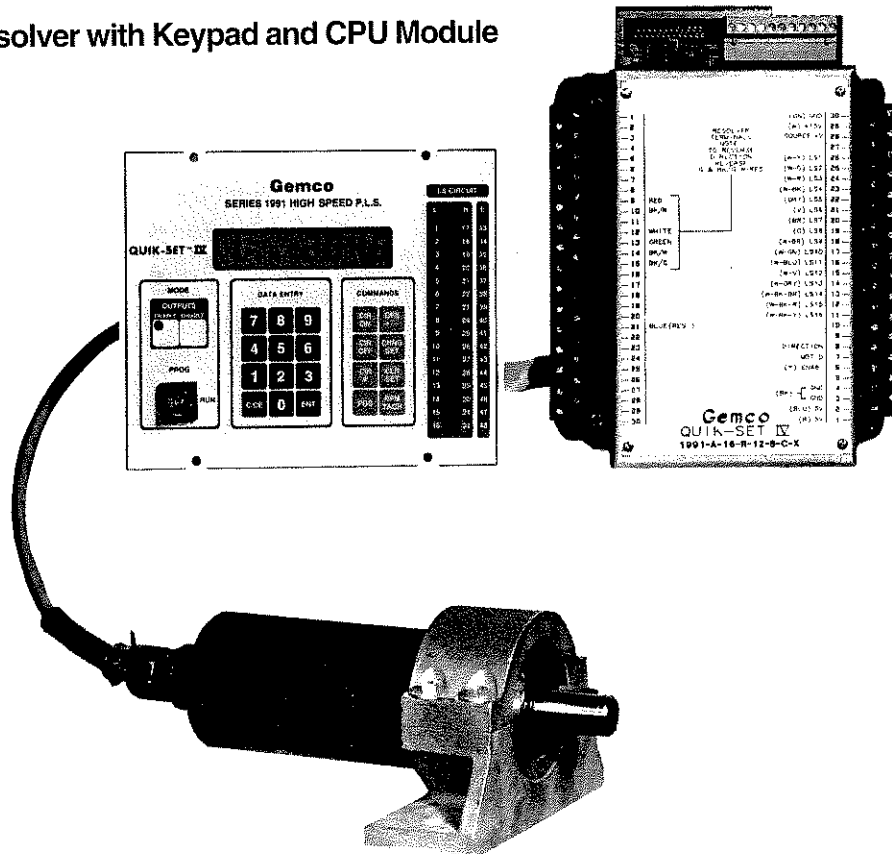

II.

INSTALLATION

Display Module and CPU Module (combined)

	Dimension X	Dimension Y
For 16 circuits only (no BCD output)	2.14	0
For 16 circuits with BCD or 32 or 48 circuits	Add .76	0
For options A, H, or R	Add .76	1.38

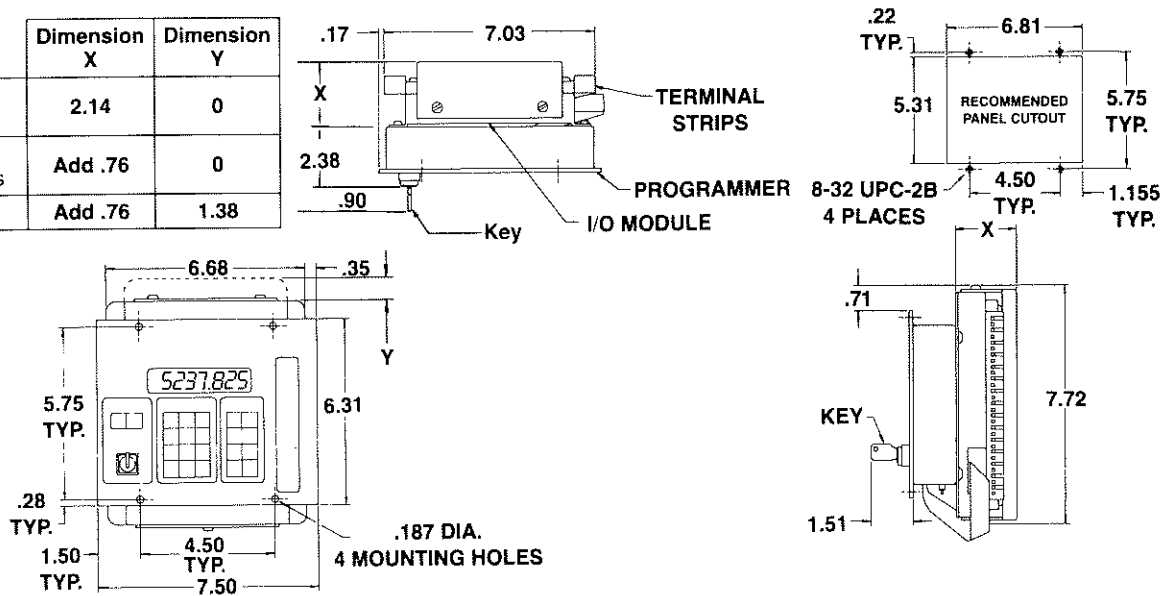

Display Module (mounted separately)

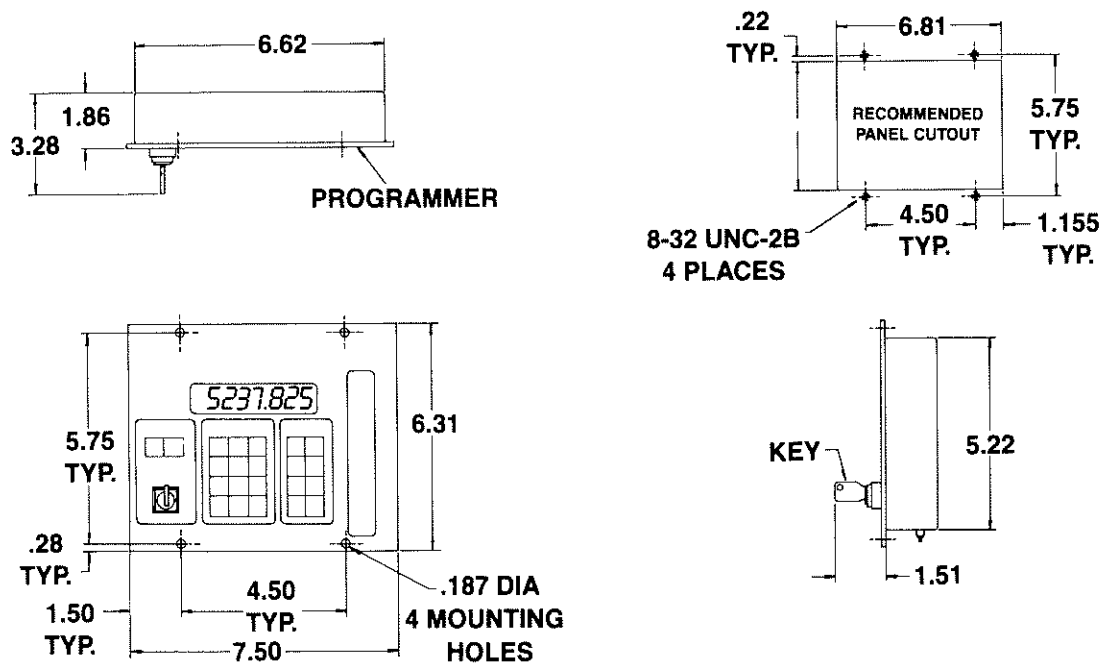

II.

INSTALLATION

Output Modules

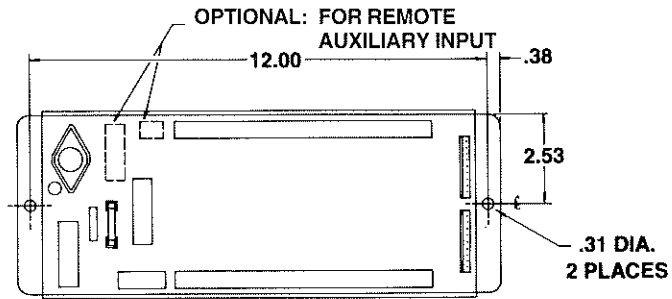

1991-0-115-P-S
P.C. Interface
Output Module
(16 Circuits)

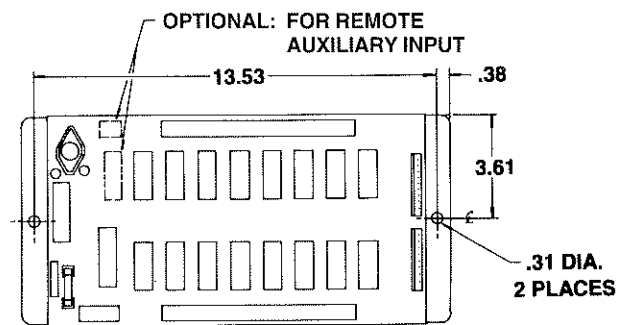
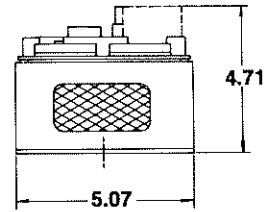
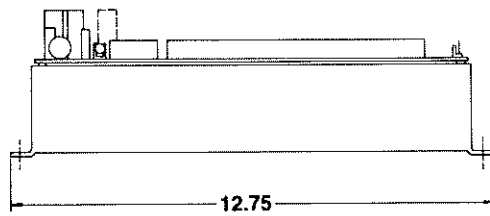

1991-0-115-A-S or 1991-0-115-D-S
AC or DC Solid State
Output Module

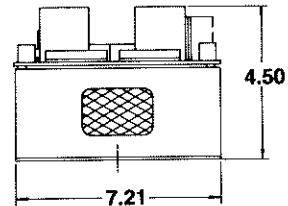
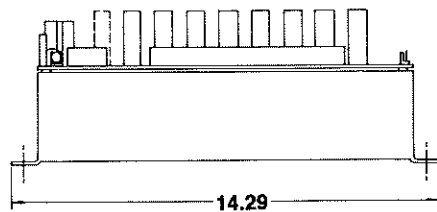

II.

INSTALLATION

Output Module

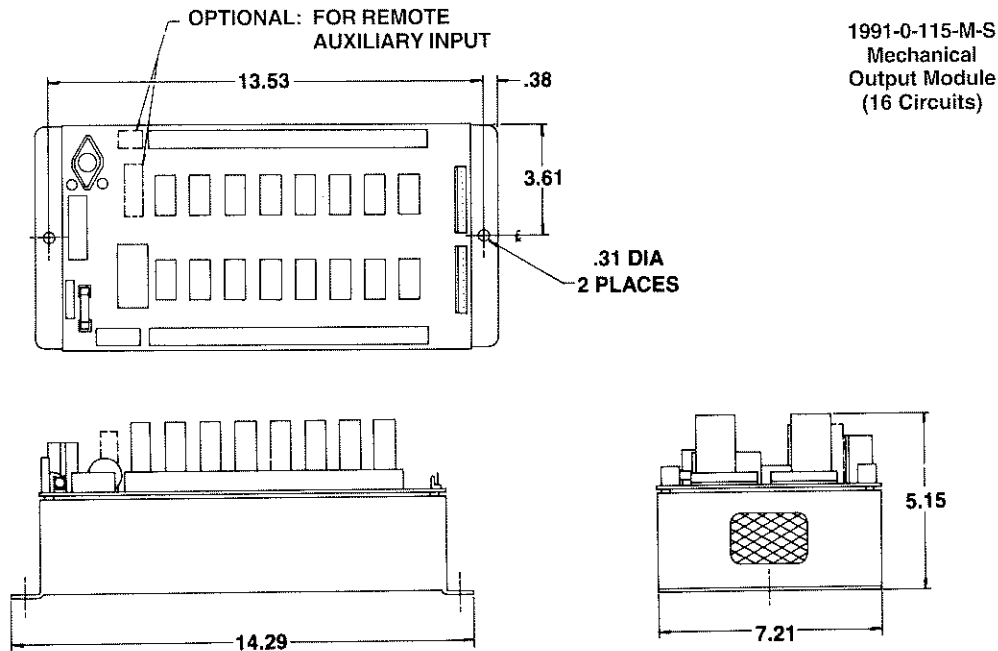

ELECTRICAL INSTALLATION

This system is designed for use in an industrial environment and incorporates extensive transient suppression circuitry. However, the same general installation rules that apply to all microprocessor-based equipment should be followed. Incoming AC lines must be from a clean power source. Lines carrying computer-level signals should not be routed in the same conduit as high-voltage, transient producing circuits, such as variable-speed drives, welders or DC switching circuits. High noise producing loads may require additional noise suppression devices.

The Series 1991 programmer is typically used with a single-turn resolver and one output module. See diagram E-0211300-C on page 11-12 for this wiring combination. Various methods of wiring each of the output modules are described in drawings E-0213001-A and E-0213002-A on pages 14 and 13.

Your CPU module legend plate and appropriate wiring diagrams taken from the Wiring Diagram Reference Chart (page 10) will define the details for your specific combination of options.

WIRING INSTRUCTIONS

Attach the pre-wired plug on the transducer cable to the transducer and route the shielded cable through a *separate* grounded metal conduit to the enclosure. Connect the edge connector to the CPU module. Be sure the shield connection is grounded to the case hold-down screw. When extensions to the factory supplied cable are necessary, a junction box should be used to connect the wire leads and cable shields from one cable to the other. Ground the cable shields at the controller case only.

Using the pre-wired shielded cable supplied with the output module, connect the larger terminal edge connector to the CPU module and the other connectors to the output modules. Connect the shield to the case hold-down screw on the CPU module.

The small ribbon cable supplied with the display module is used for connecting the display module to the CPU module. Route this cable away from other wiring. This ribbon cable must never be routed in the panel duct

which includes other wiring. Route this cable outside of the duct. Make sure the ferrite clamp is on this cable and installed closest to the CPU module.

Connect the ribbon cable to its 14 pin mating connector located through the cutout in the CPU module's metal base. Do not force this connector into the 16 pin connector located on the upper circuit board.

Due to the wide range of available options, it is virtually impossible to provide a dedicated wiring diagram for each combination. Therefore, we have provided one typical diagram covering all connections to a common single-turn resolver system. We then follow this with a series of diagrams divided into categories covering standard inputs, standard outputs, auxiliary outputs and special purpose options. Review the part number of your specific system with the part number descriptor sheet provided with your equipment or the part number development page in catalog section 1991 to verify the options it includes. Next

II.

INSTALLATION

WIRING INSTRUCTIONS CONT'D.

select the appropriate input and output wiring diagram based on your systems part number. Auxiliary outputs are then wired per the appropriate diagram. When doing all wiring, the terminal strip designations on your

CPU module should be followed if they differ from the diagrams in this manual. Some unusual variations or combinations of options may result in the relocation of some of the special purpose option terminals.

Wiring Diagram Reference Chart

Description	Diagram Number	Page
General wiring diagram single-turn resolver system	E-0211300-C	11-12
Standard outputs		
Low-power outputs from CPU module wired directly to PLC input card	E-0213002-A	13
High-power relay output modules wired to loads	E-0213001-A	14
Auxiliary outputs		
Optional analog output, remote display and RS-232/RS-485 communications output board	E-0211400-B	15
Auxiliary digital outputs	E-0216400-B	16
Auxiliary 32 and 48 limit switch output wiring	E-0216300-B	17
Internal resolver wiring		
Single-turn resolver	E-0177100-C	18

Note: All of the diagrams in this manual are available as larger full-size prints. Contact the factory and specify by diagram number if copies are required.

II.

INSTALLATION

General Wiring
Diagram E-0211300-C

1991
OUTP
DRAW

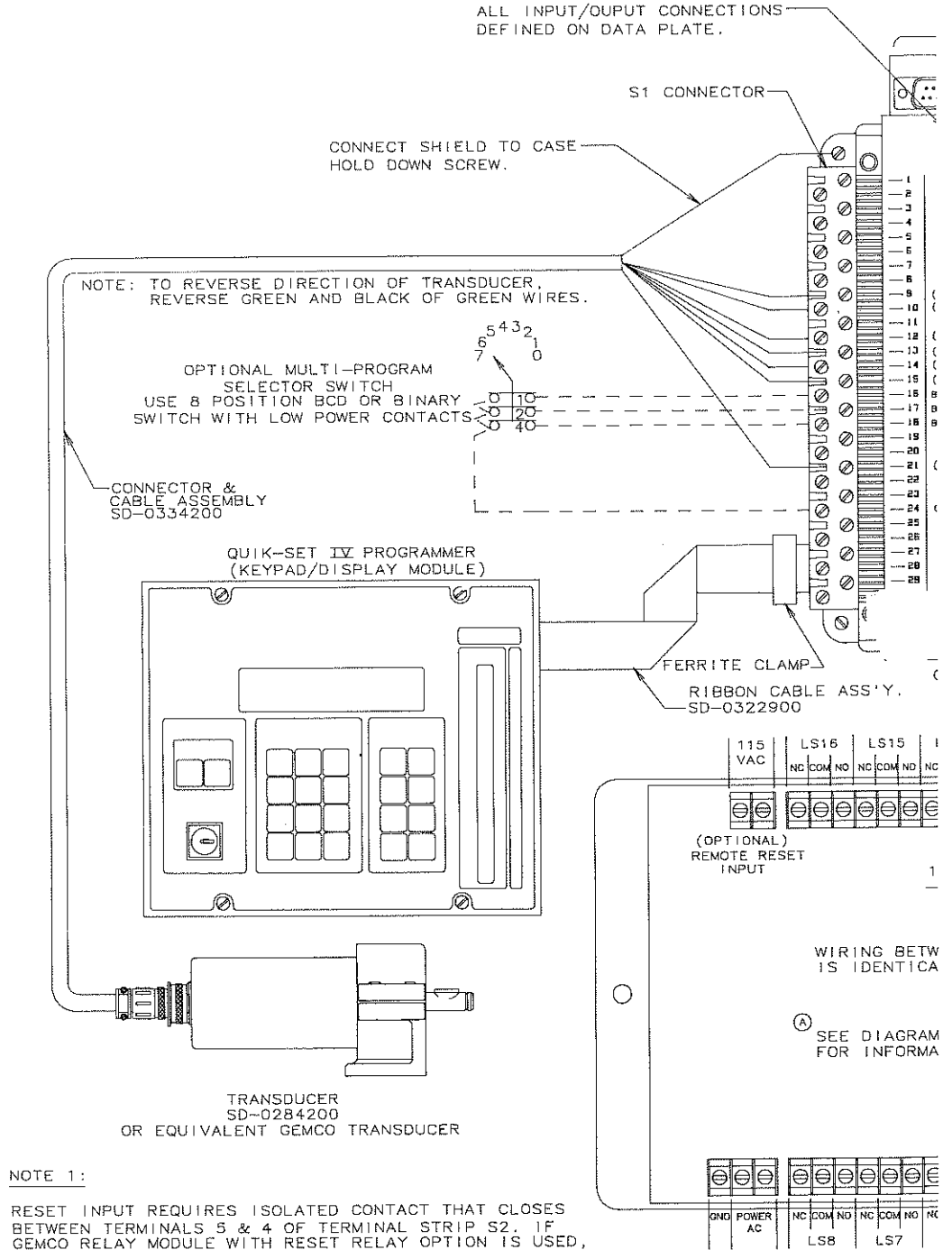

NOTE 1:

RESET INPUT REQUIRES ISOLATED CONTACT THAT CLOSES BETWEEN TERMINALS 5 & 4 OF TERMINAL STRIP S2. IF GEMCO RELAY MODULE WITH RESET RELAY OPTION IS USED, CONNECT CABLE ASSEMBLY LEADS AS SHOWN. AN AUXILIARY RELAY OR CONTACT BY OTHERS CAN ALSO BE USED FOR THIS PURPOSE.

NOTE 2:

DIRECTION AND MOTION DETECT OUTPUTS ARE LOW POWER OUTPUTS HAVING THE SAME ELECTRICAL CHARACTERISTICS AS THE LIMIT SWITCH OUTPUTS. IF SYSTEM INCORPORATES A GEMCO RELAY MODULE, ONE OF THE RELAYS CAN BE WIRED TO THESE TERMINALS TO PROVIDE A HIGH POWER OUTPUT OF DIRECTION OR MOTION.

NOTE: IF WIRING
OUTPUT
MUST BE

II.

INSTALLATION

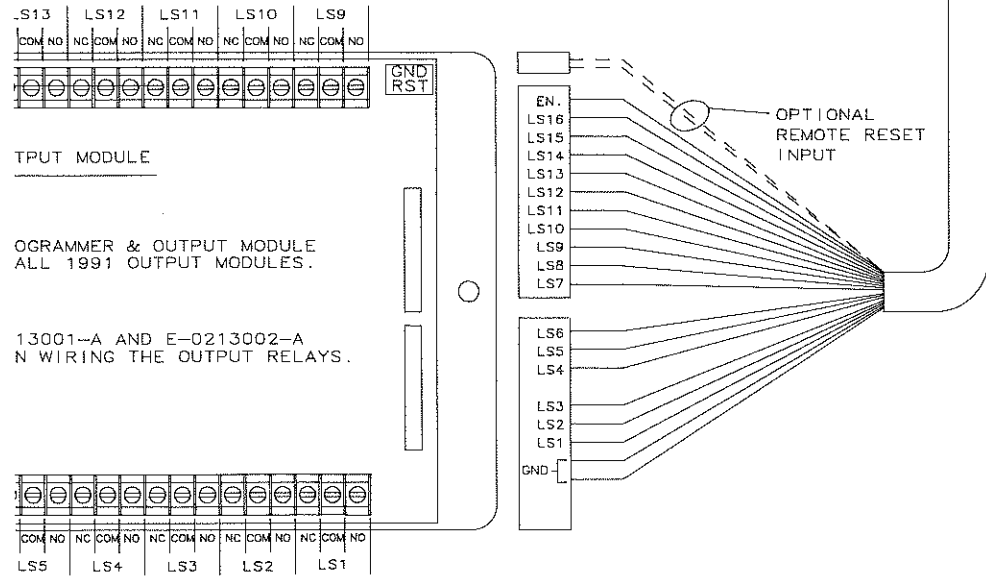
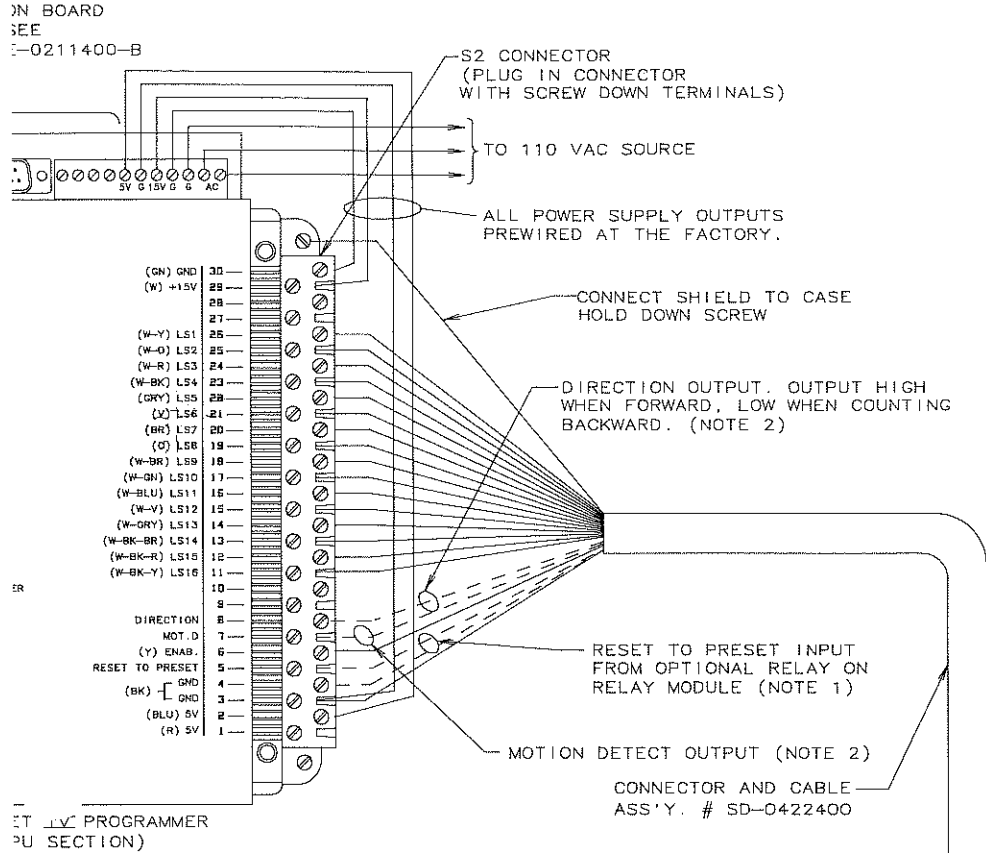

THIS DIAGRAM THE
"1991" PROGRAMMER (CPU SECTION)
NOT SINKING.



INSTALLATION

Low-Power Outputs from CPU Module Wired Directly to PLC Input Card Diagram E-0213002-A

DIRECT CONNECTION TO PROGRAMMABLE CONTROLLER SOURCING INPUT
USE GEMCO CURRENT SINKING OUTPUT
(OPTION E)

ALL POWER SUPPLY OUTPUTS
PREWIRED AT THE FACTORY.

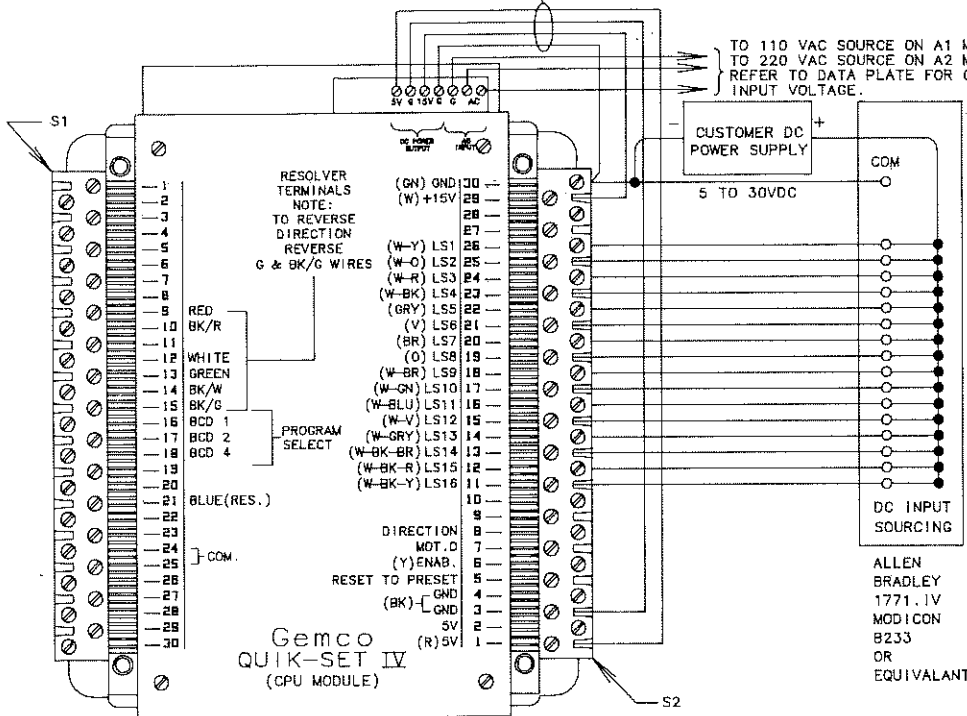

WIRING CPU OUTPUTS DIRECTLY TO PROGRAMMABLE CONTROLLER

A SOURCING OUTPUT IS REQUIRED TO OPERATE A SINKING P.L.C. INPUT. A SINKING OUTPUT IS REQUIRED TO OPERATE A SOURCING P.L.C. INPUT. WIRE PER DIAGRAM. HOWEVER, IF NECESSARY, A SINKING OUTPUT CAN OPERATE A SINKING P.L.C. INPUT BY ADDING 1K, 1W PULL UP RESISTORS FROM THE POSITIVE SUPPLY VOLTAGE TO EVERY P.L.C. INPUT. WHEN IMPLEMENTING THIS MODIFICATION, INPUT LOGIC IS REVERSED. LOW = TRUE BECOMES HIGH = TRUE.

NOTES:

- 1) THIS POWER SUPPLY OPERATES THE 1991 CPU ENCODER ONLY AND CANNOT OPERATE OTHER AUXILIARY DEVICES.
- 2) WIRING IS SIMILAR TO OPERATE A TTL INPUT CARD. V SOURCE IS NOT USED IN THIS CASE. USE GEMCO OPTION T. ALLEN BRADLEY 1771-G, MODICON B237 OR EQUIVALENT. NOTE: A SINKING INPUT CARD IS GENERALLY RECOMMENDED OVER TTL DUE TO HIGHER P.L.C. INPUT NOISE MARGINS.
- 3) TERMINAL STRIP S2 COLOR CODES ARE ONLY USED WITH GEMCO RELAY OUTPUT MODULES.

SINKING P.L.C. INPUT
USE GEMCO CURRENT SOURCING OUTPUT
(OPTION C) (SEE NOTE #2)

ALL POWER SUPPLY OUTPUTS
PREWIRED AT THE FACTORY.

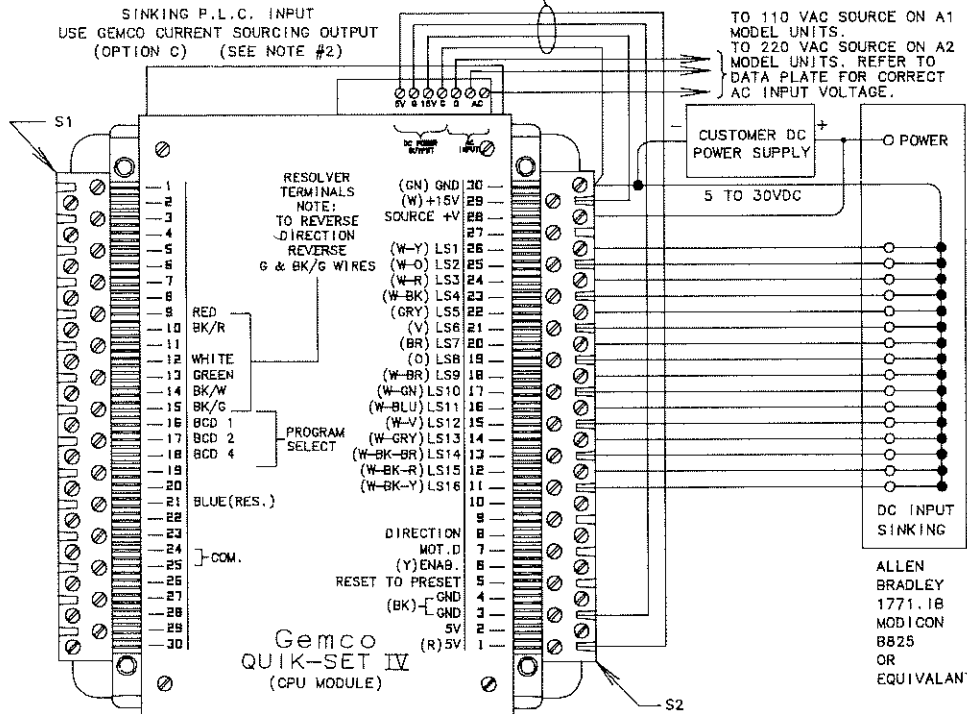

High-Power Relay Output Modules Wired to Loads Diagram E-0213001-A

STANDARD WIRING TO 1991 PLS
THRU CABLE ASSY. #SD-0422400
(SEE NOTE #5)

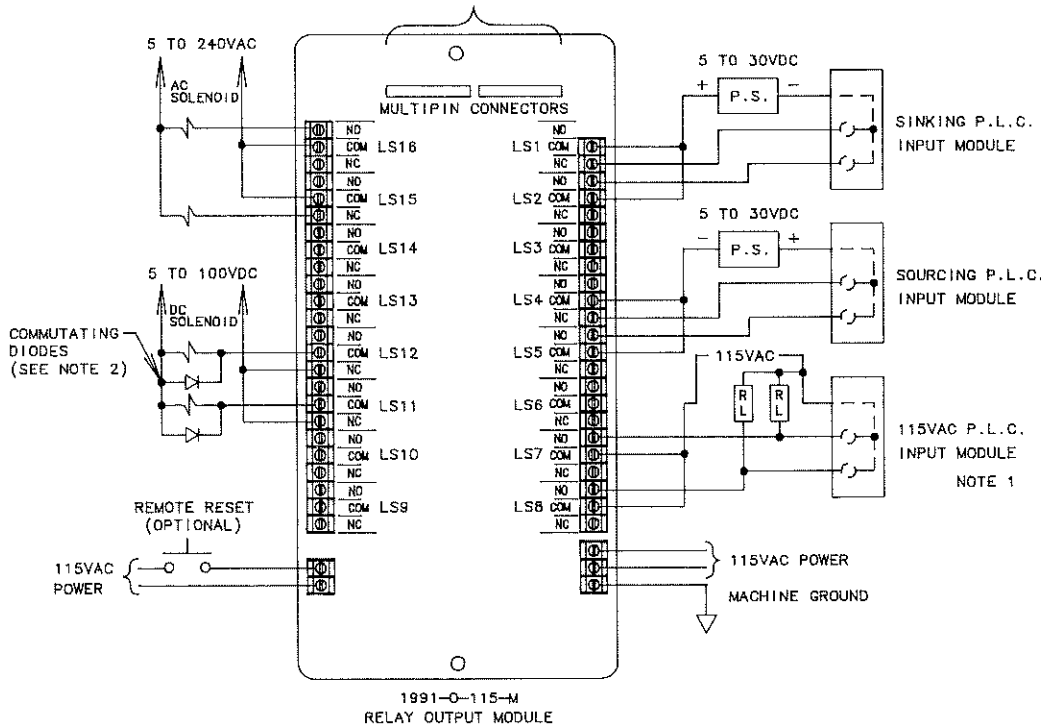

NOTES:

- 1) REMOVE SNUBBER CIRCUIT RESISTOR (R1 FOR N.O.; R2 FOR N.C.) ON APPROPRIATE LS OUTPUT OR ADD R_L LOAD RESISTOR (18K - 2W) WHEN OPERATING 115VAC P.L.C. INPUT MODULE LEAKAGE THRU SNUBBER CIRCUIT MAY KEEP P.L.C. INPUT ON.
- 2) WHEN USING THE OPEN COLLECTOR OR RELAY OUTPUT TO ENERGIZE A D.C. INDUCTIVE DEVICE SUCH AS A D.C. SOLENOID, A COMMUTATING DIODE MUST BE INSTALLED ACROSS THE DEVICE TO ELIMINATE HIGH VOLTAGE SPIKES.
- 3) TERMINAL POLARITY (+ -) MUST BE MAINTAINED WHEN USING THE OPEN COLLECTOR OUTPUT. POLARITY NOT SIGNIFICANT WHEN USING TRIAC OUTPUT. OUTPUT TYPES MAY BE MIXED ON THIS MODULE.
- 4) WHEN USING 1991 OUTPUT MODULES THE PROGRAMMER CURRENT SINKING OUTPUT (OPTION E) MUST BE USED. IF DESIRED, THE CPU MODULE OUTPUTS MAY SELECTIVELY BE USED TO DIRECTLY TO OPERATE A SOURCING P.L.C. INPUT. SEE DIAG. E-0213002-A FOR DETAILS.
- 5) THE 1991 CPU COMES WITH IT'S OWN 5 VDC & 15 VDC POWER SUPPLY. DO NOT CONNECT RED, BLUE, WHITE OR GREEN WIRES FROM OUTPUT MODULE TO CPU.

STANDARD WIRING TO 1991 PLS
THRU CABLE ASSY. #SD-0422400
(SEE NOTE #5)

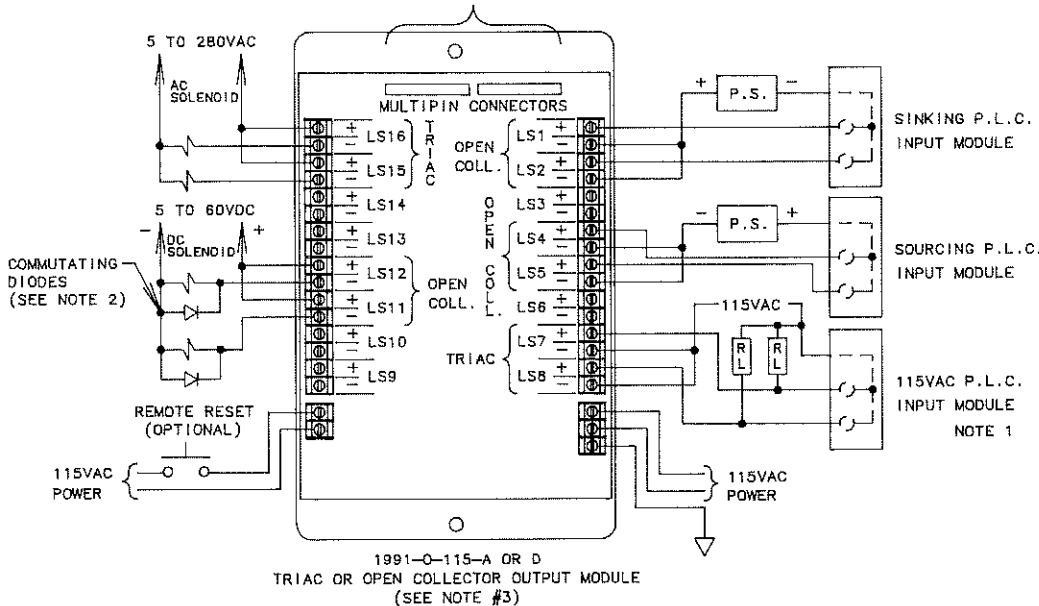



INSTALLATION

Optional Analog Output, Remote Display and RS-232/RS-485 Communications Output Board Diagram E-0211400-B

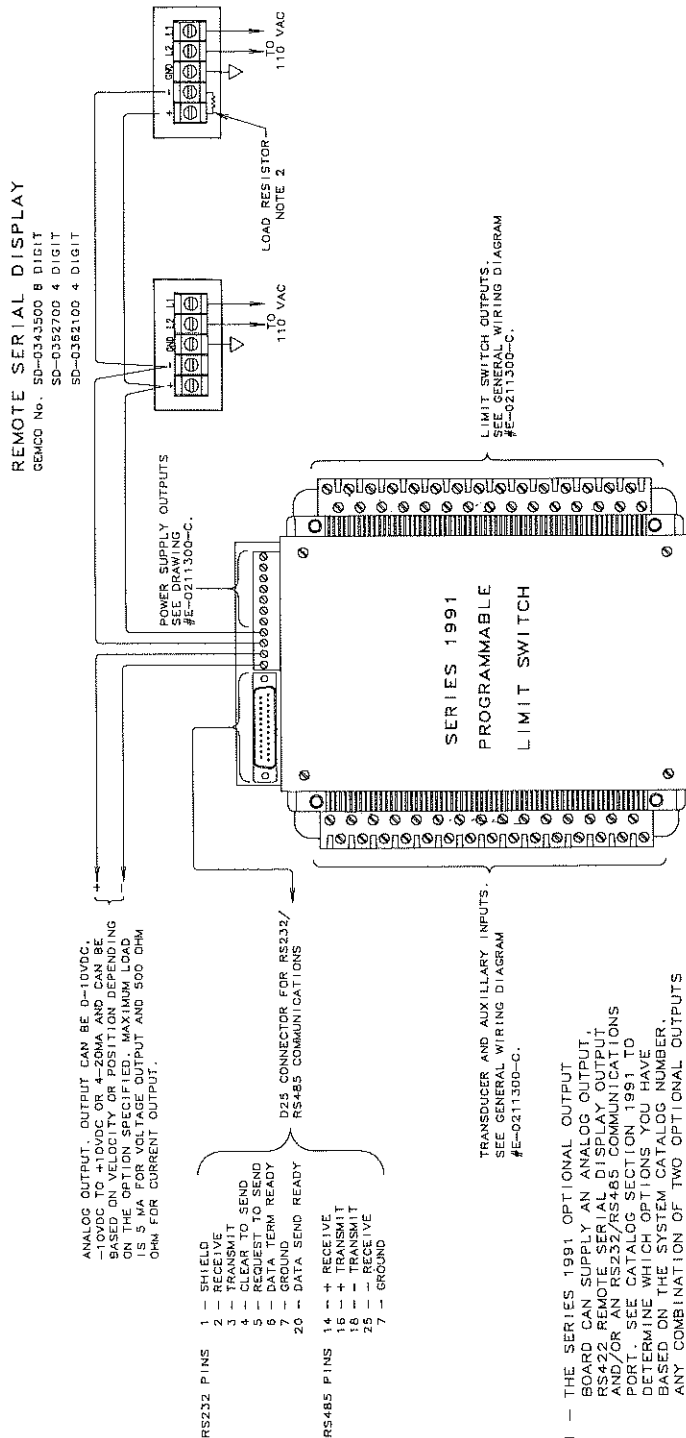

ANALOG OUTPUT. OUTPUT CAN BE 0-10VDC, -10VDC TO +10VDC OR 4-20MA AND CAN BE BASED ON VELOCITY OR POSITION DEPENDING ON THE OPTION SPECIFIED. MAXIMUM LOAD IS 5 MA FOR VOLTAGE OUTPUT AND 500 OHM OHM FOR CURRENT OUTPUT.

NOTE 1 - THE SERIES 1991 OPTIONAL OUTPUT BOARD CAN SUPPLY AN ANALOG OUTPUT. RS232, REMOTE SERIAL DISPLAY OUTPUT, RS422, REMOTE RS232/RS485 COMMUNICATIONS PORT. SEE CATALOG SECTION 1991 TO DETERMINE WHICH OPTIONS YOU HAVE BASED ON THE SYSTEM CATALOG NUMBER. ANY COMBINATION OF TWO OPTIONAL OUTPUTS ARE AVAILABLE. THE TERMINALS AND COMPONENTS FOR ANY UNSPECIFIED OUTPUTS MAY BE LEFT OFF OF THE CIRCUIT BOARD.

NOTE 2 - UP TO 10 REMOTE SERIAL DISPLAYS CAN BE DRIVEN BY THE RS422 SERIAL DISPLAY OUTPUT. WIRE ALL DISPLAYS IN A PARALLEL STRING FOLLOWING THE POLARITY SHOWN ON THE SCREW TERMINALS. THE MAXIMUM LENGTH OF ALL RS422 CABLES SHOULD NOT EXCEED 600 FEET. REMOVE THE 100 OHM LOAD RESISTOR FROM ALL DISPLAYS EXCEPT THE LAST ONE IN THE PARALLEL STRING.



INSTALLATION

Auxiliary Digital Outputs Diagram E-0216400-B

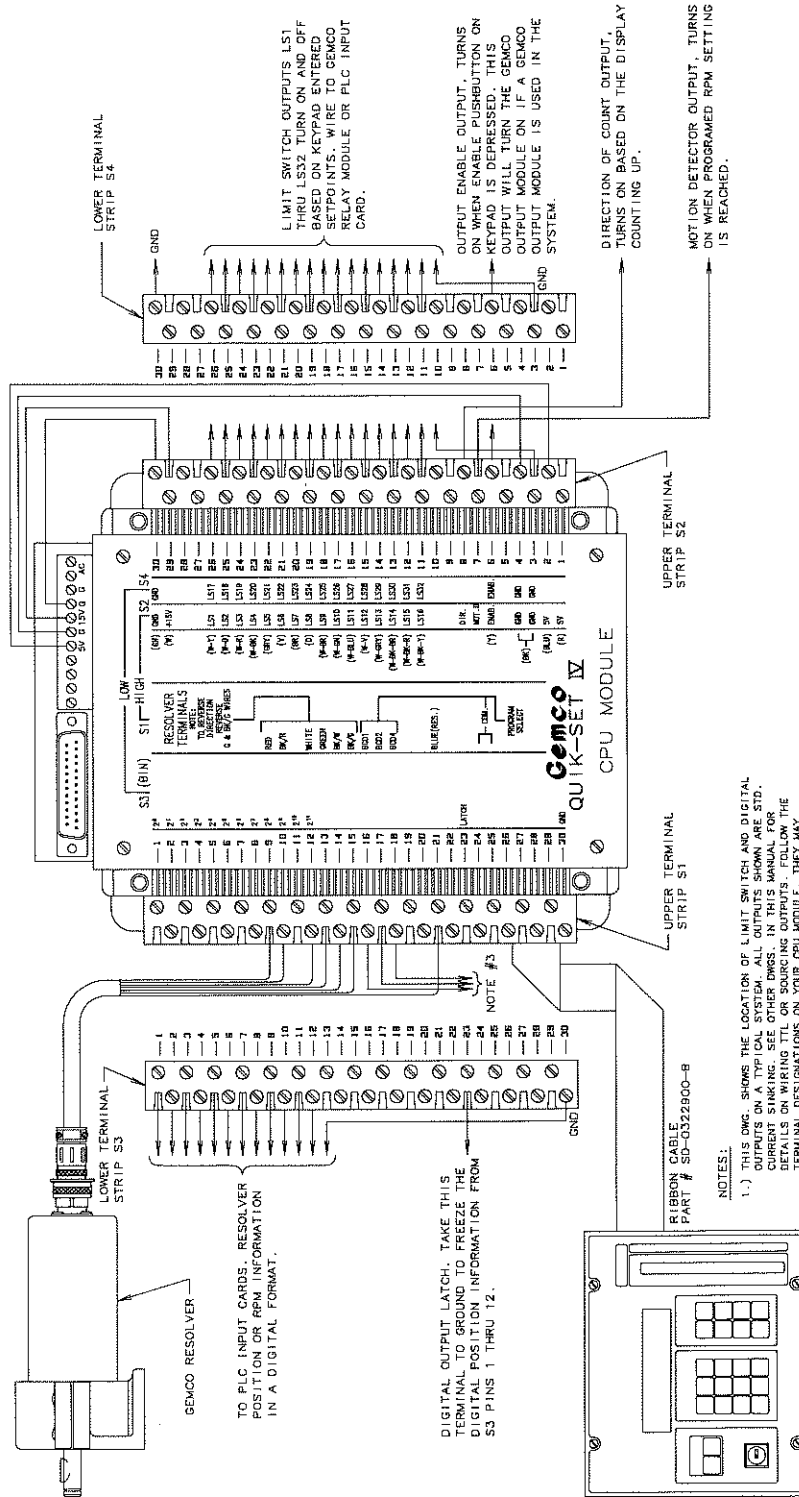



INSTALLATION

Auxiliary 32 and 48 Limit Switch Output Wiring Diagram E-0216300-B

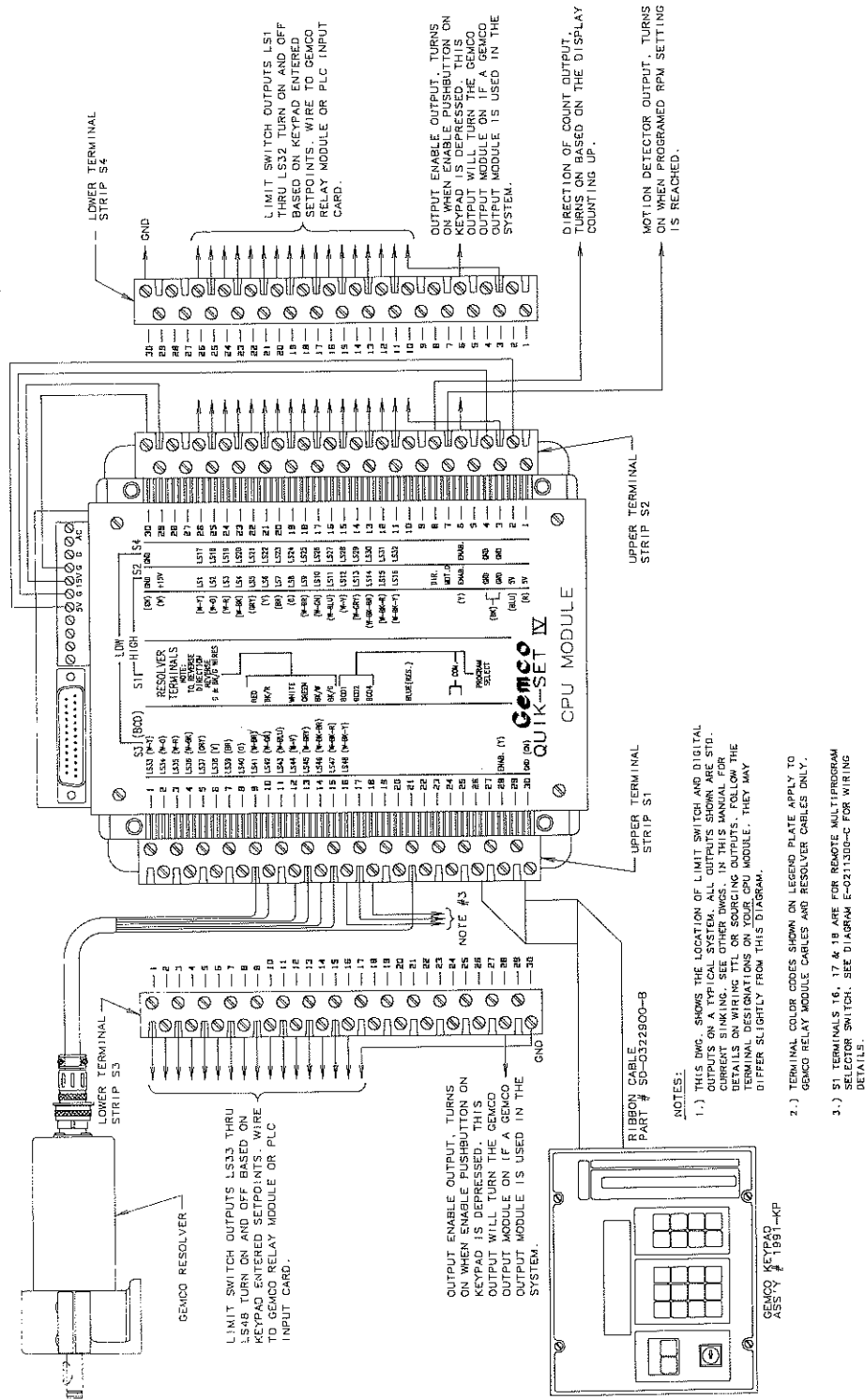

II.

INSTALLATION

Single-turn Resolver Diagram E-0177100-C

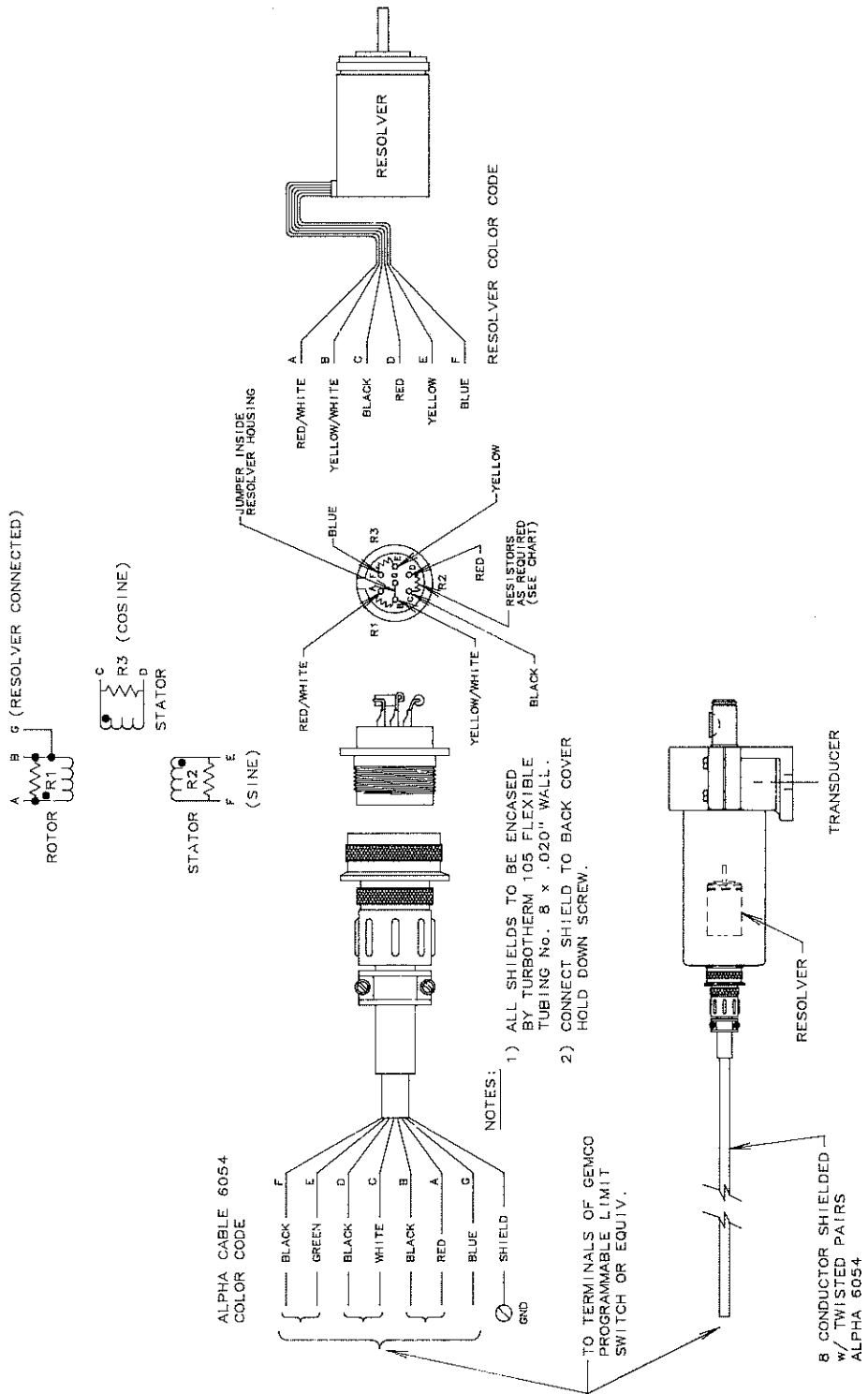



SPECIFICATIONS

QUIK-SET IV PROGRAMMER (DISPLAY AND CPU MODULE)

Resolution	12 bit standard 14 bit optional
Scale Factor Range	12 or 14 bit 2-99999
Temperature Range	Operating 32°F to 125°F Storage 0°F to 150°F
Motion Detector	Standard response time 29 milliseconds
Scan Time	Circuits 1 through 16 – 10 microseconds Circuits 17 through 48 – 200 to 500 microseconds
Total Set Points	140 per program for each of the 8 available programs
Run up/Speed Compensation Update Time	30-50 milliseconds

CPU MODULE OUTPUT TYPES

Current Sinking	Sprague ULN 2803A, 5 to 50V, 0 to 200 ma, low true (on). Cannot be used to drive TTL circuit (use with high-power output modules).
Current Sourcing	Sprague UDN 2981A, 5 to 50V, 0 to 200 ma, high true (on). Cannot be used to drive TTL circuit.
TTL	Sinking current (74LS173) up to 20 ma, high true (on).

AUXILIARY OUTPUTS

Binary Output	Current sinking, current sourcing or TTL customer-programmable for High = True or Low = True operation.
Analog Voltage	0 to 10V or -10 to +10V at 5 ma, updated every 20 milliseconds
Analog Current	4 to 20 ma, 500 OHM load maximum, updated every 20 milliseconds
RS-232 or RS-485 Communications Transceiver	Use with any RS-232 or RS-485 compatible device. Format field selected for RS-232 or RS-485
Remote Display Transmitter	Use with Gemco remote displays only
Motion Detect	Same output type as selected CPU module output

HIGH POWER OUTPUT MODULES

Mechanical Relay Output Module	
Input Voltage	115 VAC (optional 230 VAC) \pm 10% (22 VA)
Output Voltage to CPU module	22-24 VDC to current sinking limit switch outputs on CPU module
Output Type #16Q2C-D024	16 Mechanical SPDT 10 Amp isolated contact relays, pick-up 2 ms; drop-out 15 ms
P.C. Interface Output Module	
Input Voltage	115 VAC (optional 230 VAC) \pm 10% (15 VA)
Output Voltage to Programmer	22-24 VDC to current sinking limit switch outputs on CPU module
Output Type - TIL 119	16 optically isolated, Darlington sink or source, 100 ma, 1-30 VDC open collector, 0.1 ms On; 0.5 ms Off, leakage 0.1 ma
Solid State Triac Output Module	
Input Voltage	115 VAC (optional 230 VAC) \pm 10% (15 VA)
Output Voltage to Programmer	22-24 VDC to current sinking limit switch outputs on CPU module
Output Type - OAC-24	16 Triac, 3 Amp, 280 VAC maximum, zero crossing 0-8 ms On; 0-8 ms Off, leakage 5ma @ 280 VAC
Solid State Open Collector Output Module	
Input Voltage	115 VAC (optional 230 VAC) \pm 10% (15 VA)
Output Voltage to Programmer	22-24 VDC to current sinking limit switch outputs on CPU module
Output Type - ODC-24	16 optically isolated, sink or source, 3 Amp, 60 VDC open collector, 0.1 ms On; 0.75 ms Off, leakage 1 ma @ 60 VDC

IV.

PROGRAMMING

Note: Programming of the scale factor will delete all programmed data held in memory. Therefore, it should be the first step in your set-up procedures.

KEYBOARD FUNCTIONS

Run/Prog Selector

The key selector in the lower left hand corner of the keypad prevents unauthorized changes to the programmed functions. With the key in the program (PROG) mode, all functions of the controller can be programmed. With the key in the RUN mode, all set points, scale factor, decimal point, offset, motion detection, and other optional functions can be verified, but the programmed information cannot be changed.

Circuit on/off Commands

On a standard 16 circuit programmer, the outputs of circuits LS1-LS16 can be programmed to turn on or off by pressing the appropriate key. An output status LED lights when the outputs are called for. All outputs are enabled when the key selector is turned to the RUN mode. The enable/disable key does not function unless the key lock is in the PROG mode.

The 16 output status LED's illuminate to indicate that the output has turned ON. When the status of outputs 1-16 are being monitored by the LED's, the letter L is displayed on the left side of the digital display. On 32 or 48 circuit units, the letter H or E will be displayed to indicate that the output status LED's are monitoring the status of circuits 17-32 (H) or 33-48 (E). To monitor the status of a particular group of outputs, call up any circuit in that group using the keypad sequences described below under "selecting a circuit for programming."

An L, H or E will be displayed to indicate that the output status LED's are monitoring the status of that

particular group of outputs.

The output status LED's indicate the actual status of the low-power outputs in the CPU module. If a Gemco high-power output module is used in the system, the corresponding high-power output relay will be turning on and off with the status output LED's. This only occurs when the enable/disable key has been enabled.

Enable/Disable Key

When the enable/disable keys are pressed, the low-power output labeled "enable" on the CPU module will activate. If your system includes a Gemco high-power output module, the output module will be enabled or disabled by pressing these keys. These keys do not affect the low-power LS outputs from the CPU module. If these outputs are being fed directly to a PLC, you must remember that the enable/disable keys will have no effect on the output signals seen by the PLC. The output from the enable terminal of the Gemco CPU module could be used as an input to the PLC and your software could be written to use this input to enable or disable the PLC outputs.

The enable/disable keys will only function when the PROG/RUN selector is in the PROG position. The outputs are automatically enabled when the selector is put in the RUN position.

This feature allows the PLS to be programmed and the outputs to be verified prior to turning the control of the machine over to the PLS outputs.

SCALE FACTOR PROGRAMMING

Insert the key in the Prog/Run key switch, turn to the PROG position. Press the "disable" key. This turns off the "enable" LED on the output module and disables the high power relays on the output module.

Prior to Programming-Only: Enter the following key commands to clear any existing programmed data:

CIR#, 3, 9, 1, ENT

The display will go blank for a few seconds while the programmer is clearing all memory. When the display is operating again, enter the scale factor.

To calculate a scale factor:

The scale factor is the maximum number that the PLS will count to over the full output range of the transducer.

A Single-Turn Resolver provides absolute position data over one turn of its input shaft before repeating. On rotary applications, a scale factor of 360 or 3600 will provide position data in degrees or 1/10 of a degree. If one revolution of the resolver shaft represents a linear machine stroke, a scale factor can be selected that provides position data in linear engineering units appropriate for the application. Example: A single-turn resolver is rack and pinion

driven so that the resolver makes one complete revolution over 18.80 inches of machine stroke. A scale factor of 1880 would provide position data and the programming of set points to 1/100 of an inch.

Gemco does manufacture resolver packages consisting of a single-turn resolver with an internal precision gear reducer. The effect of this gear ratio must be considered when calculating the scale factor for this type of transducer. The scale factor will be the amount of machine travel that results in one turn of the resolver located on the output side of the gear reducer.

To enter a new scale factor:

1. With the display in the PROG mode, press POS and enter the scale factor.
2. Press the scale factor button located on the back of the keypad module near the ribbon cable connector. The display will blank and return to the current position of the transducer. The new scale factor will remain in effect until another is entered.
3. To check the existing scale factor, press the scale factor button only.

Next, turn the transducer shaft to determine the

IV.

PROGRAMMING

direction of rotation. If the LCD readout on the module decreases as the position of rotation increases, the direction of rotation may be reversed on single-turn resolvers by interchanging the green and black of green wires from the transducer at the CPU module.

It is recommended that the 0° "start cycle position" of the machine be determined and the

resolver be mechanically zeroed by loosening the four bolt heads on the mounting foot and rotating the resolver until the display on the module reads zero. The bolts should then be retightened and additional fine adjustments made using the offset programming function below.

DECIMAL POINT PROGRAMMING

A continuous, non-floating decimal point may be programmed on the display. If a scale factor is selected that needs a decimal point in order to properly display its resolution in engineering units, the following 50 series codes are used:

- 50 - no decimal point, clears existing decimal point
- 51 - tenths
- 52 - hundredths
- 53 - thousandths

54 - ten thousandths
Insert the appropriate 50 series code in the following sequence:

CIR#, 50 series code, ENT

Example: A scale factor of 3600 has been selected for a rotary application to display degrees to a tenth of a degree. To program a decimal point in the tenths position press:

CIR#, 5, 1, ENT

OFFSET VALUE

The offset key is used to synchronize the digital display with actual machine position. The Series 1991 PLS has full scale factor offset capabilities and the offset is held in nonvolatile memory. However, to eliminate possible problems should a replacement PLS be required, it is good practice to mechanically synchronize the resolver with the machine and then use the offset key to make final, fine adjustments. To use the offset key, the machine must be taken to a known position. The offset key is then pressed, followed by the known machine

position, then ENT.

Example 1: A machine is jogged to its home or zero position, but the PLS display is reading 12. To synchronize the PLS display with actual machine position, press:

OFS, 0, ENT

Example 2: An automated hoist system is stopped at elevation 200.0, but the PLS display is reading 196.7, press:

OFS, 2000, ENT

SET POINTS

Selecting a Circuit for Programming

For new or existing set points, first select the limit switch output you want to program. Do this by pressing the CIR# key, followed by the circuit number, followed by ENT. For example, to select circuit number 3 for programming press CIR#, 3, ENT.

Entering new set points

Each set point specifies the position at which the circuit is to be turned on or off. The set points must be entered using all digits to the right of the decimal place even if they are zeros. A new set point for the current circuit may be entered by pressing the "CIR ON" key, followed by the position, then ENT. OFF set points are programmed the same except that the "CIR OFF" key is pressed to begin the sequence.

Example: To program the selected circuit to turn on at 25 and off at 125, press:

CIR ON, 2, 5, ENT

CIR OFF, 1, 2, 5, ENT

Additional set points can be programmed on the selected circuits by continuing the above sequences.

If there is more than one set point on the circuit, all decimal points on the display will flash as a visual warning to the programmer that multiple set points are programmed for that circuit. To verify the set points press the "CIR ON" or "CIR OFF" key repeatedly to display all of the points currently held in that circuit's memory.

Note 1: Any ON set point without a corresponding

OFF will cause the output to turn on and stay on through any higher number. Any OFF set point without a corresponding ON set point will cause the circuit to be on at any lower number and be off through any higher number. On rotary applications, the status of these single set point outputs will reverse as resolver position crosses zero. On linear applications, the use of this concept can simplify programming sequences where the output is intended to activate at a specific point and stay in that condition through all continued movement in the same direction. However, steps must be taken to insure that the resolver position cannot roll over through zero which would result in a reversal of the output's status.

Note 2: When the outputs have been programmed, the output status LED's on the keypad will turn on and off as the transducer is rotated to indicate that the outputs are being activated. Press the "enable" key to activate the relay output module after visually verifying the program.

Modifying Existing Set Points

Changing a set point

The CHNG SET (Change Set) key is used to change the value of an existing set point. To use this key, first select a circuit. Press the "CIR ON" or "CIR OFF" key to display the set point to be modified. On circuits having multiple set points, the "CIR ON" or "CIR OFF" key is pressed repeatedly until the desired

IV.

PROGRAMMING

SET POINTS CONT'D.

set point is displayed. The new value for the selected set point is now entered on the keypad, followed by CHNG SET. Upon pressing CHNG SET, the old set point value will be deleted and replaced with the new value. The conversion from one set point to another is completed during the first full scan of the software loop, which is generally 100-500 microseconds depending on the software options. This high speed capability allows fine tuning while the machine is in operation.

Example: To change an ON set point of circuit number 3 from 180 to 181 press:

CIR#, 3, ENT
"CIR ON" until 180 is displayed
1, 8, 1, CHNG SET

Deleting a set point

The CLR SET (Clear Set) key is used to delete an existing set point. To use this key, a circuit is first selected for programming. Press the "CIR ON" or

"CIR OFF" key to display the set point to be deleted. With circuits having multiple set points, press the "CIR ON" or "CIR OFF" key repeatedly until the set point to be deleted is displayed. Press the CLR SET key to delete the set point.

Example: To delete the ON set point on circuit 1 which is currently set at 26 press:

CIR#, 1, ENT
"CIR ON" until 26 is displayed
CLR SET

The above sequence will delete the ON set point but has no effect on any corresponding OFF set point. Because most control functions consist of ON and OFF settings, you must remember to delete any corresponding set point to eliminate the type of operation described under Entering New Set Points; Note 1.

MOTION DETECTION

The motion detect output is used to provide an output based on the rotational velocity of the transducer. This output can be programmed to operate at any speed between 5 and 1000 RPM. Use the following sequence to program the motion detect RPM value:

1. Press RPM TACH key
2. Enter the RPM value at which the motion detect output is desired.
3. Press the red scale factor button located on the back of the keypad, near the ribbon cable connector.

To verify the programmed value, repeat the above steps, skipping step 2.

The motion detect output will be a low power output located at terminal 7 of terminal strip S2. The electrical characteristics of this output will be the same as the limit switch outputs (current sink, current source, or TTL.) If your system includes a Gemco relay output module, one of its relays can be wired to this terminal to provide a high power output based on RPM.

CAUTION: Display module must be in RPM mode when steps 2 and 3 are performed. If display is in POS mode when these steps are performed, you will have changed the scale factor and cleared all programmed limits and offsets.

MINIMUM SPEED DISABLE

The minimum speed disable function allows selected circuits to be programmed to automatically turn off when RPM drops below a programmed value, regardless of the position of the machine. This feature is typically used to turn off glue guns if the machine comes to a stop with product in a glue station, preventing a continuous stream of glue.

The programming of this function is performed in two steps. The RPM value, below which the outputs turn off, is programmed using access code 85. The number of circuits to be disabled is then programmed using access code 86. When programming the number of circuits, the affected circuits will always start with output Circuit 1 and increase in numerical sequence to

the number specified. If four circuits are programmed for minimum speed disable, they will be output circuits 1, 2, 3 and 4. If six are selected, they will be 1, 2, 3, 4, 5 and 6.

Example: A packaging machine has six glue guns that need to be disabled whenever machine velocity drops below 5 RPM, press:

CIR#, 8, 5, ENT, 5, ENT (sets RPM value at 5)
CIR#, 8, 6, ENT, 6, ENT (selects six circuits to be disabled)

Per the above example, output circuits 1, 2, 3, 4, 5 and 6 will turn off whenever machine velocity drops below 5 RPM.

The maximum number of circuits that can be programmed for this function is sixteen.

Note: Advanced features and options are factory installed as original equipment. Check Part Number Descriptor Sheet for specific options that apply to your system.

PROGRAMMER OPTIONS

Linear Speed Compensation

This feature allows selected circuits to be programmed to automatically advance and retard as resolver speed increases or decreases. Independent rates of advance and retard are allowed on both the leading and trailing edge of the programmed set points. This allows full compensation for both the ON and OFF response time of the machine function being manipulated for precise control of its location and duration within the machine cycle.

Typical applications include providing run-up control of glue guns on high speed packaging machines. The independent rate of advance on the leading and trailing edges of the dwell controlling a glue gun allows full compensation for variations in its turn on and turn off response time.

Any of the first 16 limit switch outputs can be programmed for speed compensation. Special access codes are first used to access the ON set points of the desired circuit for programming their rate of advance. The CIR ON and CIR OFF keys are then used to program a ratio that represents the amount of advance per change in RPM. A second special access code is then used to access the OFF set points of the same circuit for programming their rate of advance. The CIR ON and CIR OFF keys are then used to program the advance per RPM change ratio. When using the CIR ON and CIR OFF keys to establish this ratio, you are establishing a slope or rate of change that will continue above or below the actual numbers programmed in. A programmed ratio of 10 counts per 100 RPM change is the same as 1 count per 10 RPM change or 100 counts per 1000 RPM change. Since the rate of change can be different for the ON and OFF set points of a set point dwell, the output circuits can be programmed to provide an opening or closing dwell as the position of the dwell advances over RPM increases. If a programmed limit switch output has multiple dwells, all ON set points will follow the same advance ratio and all OFF set points will follow their programmed advance ratio.

Special access codes 501 through 516 are used to access the ON set points of limit switches 1 through 16 for programming their rate of advance.

Special access codes 601 through 616 are used to access the OFF set points of limit switches 1 through 16 for programming their rate of advance.

A typical programming sequence will follow this format.

To program ON set point speed compensation rate:

CIR#, (501-516), ENT
CIR ON, (amount of offset), ENT
CIR OFF, (RPM range), ENT

To program OFF set point speed compensation rate:

CIR#, (601-616), ENT
CIR ON, (amount of offset), ENT
CIR OFF, (RPM range), ENT

Example: It's determined that the limit switch set points of output circuit 4 need to advance at a rate of 6 counts per 100 RPM increase to compensate for the

turn-on time of a glue gun. The turn-off time of this glue gun is slower than its turn-on time so the rate of advance of the OFF set points must be 8 counts per 100 RPM increase.

To program, press:

CIR#, 5, 0, 4, ENT
CIR ON, 6, ENT
CIR OFF, 1, 0, 0, ENT
CIR#, 6, 0, 4, ENT
CIR ON, 8, ENT
CIR OFF, 100, ENT

Following the above example, all ON set points on limit switch output 4 will linearly advance at a rate of 6 scale factor counts per 100 RPM increase in machine velocity. All OFF set points on this circuit will advance at a rate of 8 scale factor counts per 100 RPM increase, resulting in a dwell (distance between the ON and OFF set point) that closes at a rate of 2 scale factor counts per 100 RPM increase. These set points will continue to advance at these same rates as machine velocity continues to increase above 100 RPM. An output originally programmed to turn ON at 100 and OFF at 150 would operate as noted below:

RPM	Turn ON point	Turn OFF point
50	97	146
100	94	142
150	91	138
200	88	134

These turn-on and turn-off points will advance linearly between the RPM points listed above whenever the RPM increases enough to result in a one count change in position.

All set points will retard at the same rate as RPM decreases.

All changes due to RPM fluctuations will be updated every 30 to 50 milliseconds.

Note: See minimum speed disable feature on page 22 for other typical glue gun control functions.

Multi-Program

The Multi-program feature makes it possible to store eight separate operating programs with single or multiple dwells on up to 48 circuits simultaneously. This allows for rapid changeover from one set of manufacturing parameters to another without slowing production.

Program selection can be made by either a remote BCD switch input or through keypad selection. The display digit farthest to the left indicates which program is operating. Units are shipped factory set to multiple program selection via keypad entry.

The following initial keypad selection determines which mode of program selection is used. Press:

- CIR#, 375, ENT, 0 or 1, ENT
- a. 0 selects remote BCD switch input program selection
 - b. 1 selects keypad program selection

V.

ADVANCED FEATURES AND OPTIONS

PROGRAMMER OPTIONS CONT'D.

Program Selection through Keypad Entry - Program selection is made by keypad entry with the Program Key Switch in the PROG mode. To change programs, press:

CIR#, Program Code, ENT

The display will momentarily blank while the selected program is being initialized. When digits reappear on the display, the unit is ready to operate.

Prog. Num.	0	1	2	3	4	5	6	7
Prog. Code	770	771	772	773	774	775	776	777

When programming is complete, it is recommended that the Program Key Switch be returned to the RUN position and the key removed to eliminate any possibility of unauthorized data being entered.

Program Selection through Remote BCD Switch Input - A BCD input (0 to 7) is applied to 4 terminals (3 signals and common) on the CPU module of the PLS, to select the desired operating program. The BCD switch must be able to sink 15 VDC at 20 ma to the common to select programs, High = 1 (contact open).

Input	000	001	010	011	100	101	110	111
Prog. Num.	0	1	2	3	4	5	6	7

To clear all set points in the selected operating program, while in the PROG mode press:

CIR#, 91, ENT

To clear all set points from all programs, while in the PROG mode press:

CIR#, 391, ENT

Option A - Analog Output

With this option, the PLS can control analog devices by creating an analog output proportional to resolver position or velocity. This output is available in either 0 to 10 VDC, -10 VDC to +10 VDC or 4-20 ma versions. It is keypad selectable to provide either position or velocity (RPM) based data. The position or RPM values between which the minimum and maximum analog output develops are keypad programmable. Steady state minimum and maximum analog outputs can be called up via the keypad for calibration purposes of the analog devices receiving this output signal.

Typical applications include controlling the pressure of pneumatic glue gun systems, variable speed drives, or data recording. Refer to diagram E-0211400-B on page 15 for wiring details.

To program the analog output to be based on Position or RPM or for the steady state minimum or maximum values for calibration purposes, press:

CIR#, 2, 0, 2, ENT

The display will show a 0, 1, 2 or 3 to indicate the mode currently selected.

- 0 = Position based analog output
- 1 = RPM based analog output
- 2 = Steady state minimum analog output
- 3 = Steady state maximum analog output

To change the output mode, continue the programming sequence by pressing the appropriate code (0 through 3) followed by ENT.

Example: To program the analog output to be

based on RPM, press:

CIR#, 2, 0, 2, ENT, 1, ENT

The position or RPM values between which the analog output rises from its lowest value to its maximum value are programmed using access codes 203 and 204. Access code 203 is used to program the position or RPM value at which the maximum analog output is reached and access code 204 is used to program the position or RPM value at which the minimum analog output is reached.

Example: To program a 0-10 VDC analog output to rise from 0 VDC to 10 VDC between 50 RPM and 400 RPM, use code 202 to select the RPM mode following above example, then press:

CIR#, 2, 0, 3, ENT, 4, 0, 0, ENT

CIR#, 2, 0, 4, ENT, 5, 0, ENT

The 0-10 VDC analog output will now be 0 VDC at any velocity below 50 RPM. As the transducer velocity exceeds 50 RPM, the output will linearly rise from 0 VDC to 10 VDC at 400 RPM. At velocities above 400 RPM, the analog output will remain at its maximum value of 10 VDC.

There are no provisions in this software to allow programming of an analog output that does not swing through its full output range. However, access codes 203 and 204 can be used to scale the output beyond the operating range of your system. For example, if you want a 0-8 VDC output based on position and your systems scale factor is 360, access code 203 can be used to program a maximum analog output position of 450. As the system counts from 0 to 360 over one revolution of the resolver, the analog output rises from 0 towards 10 VDC at a rate that would result in 10 VDC out at position 450. However, since the system rolls over to zero at 360, the analog output voltage would only rise to 8 VDC before dropping back to zero as the resolver position crosses through zero.

The steady state minimum and maximum output values, accessed through code 202, are intended to allow you to adjust the gain on the device receiving this output signal. These steady state analog outputs allow you to calibrate the device receiving this signal while the machine is stationary.

The analog output will update its value every 30 to 50 milliseconds depending on the output options of the overall system.

Option B - Binary Output

The Series 1991 PLS was designed for use on very high speed applications. Because of this basic design criteria, it was determined that auxiliary digital outputs of position had to be derived from outside the main software loop to insure an update time compatible with its intended function. Therefore, the standard digital output of position is the full 12 bit binary developed in the early stages of our resolver to digital conversion circuitry. This output will always count from 0 to 4095 in a binary format, regardless of the programmed scale factor. This output will follow any programmed offset used to synchronize the PLS with machine position so that zero position of the programmed scale factor will be zero at the digital output terminals.

A digital output of position will update every 10

V.

ADVANCED FEATURES AND OPTIONS

PROGRAMMER OPTIONS CONT'D.

microseconds.

If the digital output is programmed for RPM data instead of position, the main software loop is used to calculate RPM so the digital output update time will be 30-50 milliseconds. The digital output will count directly in RPM units in a binary format.

A latching input is provided to freeze the output data to allow sufficient time for the PLC to reliably read the output data.

The electrical characteristics of the digital output drivers and latch input are specified by the letter designation inserted after the B option specifier in the part number. (E = current sinking, C = current sourcing, T = TTL)

Units are shipped from the factory set to provide digital outputs based on position and a logic format of active = True. To verify these operating parameters, press CIR#, followed by the access code followed by ENT. The display will show a 0 or 1 to indicate the current mode of operation. To change, continue the sequence by inserting the appropriate number (0 or 1) followed by ENT.

To select position or RPM data, press:

- CIR#, 1, 6, 9, ENT, (0 or 1), ENT
- 0 selects position data
 - 1 selects RPM data

To select the logic format, press:

- CIR#, 7, 5, ENT, (0 or 1), ENT
- 0 selects inactive (off) = True
 - 1 selects active (on) = True

Option O - Remote Reset to Preset

This option allows the position of the PLS to be reset to a keypad selected value based on an input from a remote contact or proximity switch mounted at a known location on the machine. Typical uses include compensation for slippage of idler wheel-driven resolvers, cable stretch, gear train backlash and to synchronize outputs with the leading edge of products moving through a machine.

The PLS position will reset to the selected value within 200 microseconds of seeing the leading edge of the contact closure input wired between the CPU module reset input terminal (terminal strip S2 terminal 5) and ground. This input terminal carries a computer level signal that should not be routed through a noisy electrical environment to a remote location on the machine. Review general wiring diagram E-0211300-C on page 11-12 and note that the Gemco relay output modules can be ordered with a remote reset relay. This option allows a 110 VAC input from a remote switch to be wired to terminals on the output module. Upon seeing this 110 VAC input, a solid state relay on the output module energizes to provide the contact closure input to the CPU module.

Any standard control relay can be used for this same purpose. If the reset input is from a button, or other control relay, mounted near the CPU module, its contact can be wired directly to the input terminals if the wiring is routed to avoid electrical noise.

All recalculations of position due to this input are held in RAM and will be lost whenever power is interrupted. Therefore, it should only be used to

compensate for minor changes in synchronization or in applications where loss of the reset value will not create a hazardous condition.

To program the remote reset to preset value, press:

CIR#, 1, 6, 0, ENT

The display will now show the current reset value. To change the value, continue the keypad sequence by entering the new value followed by ENT.

Example: To program a reset value of 200, press:
CIR#, 1, 6, 0, ENT, 2, 0, 0, ENT

Option R - Remote Serial Display

This programmer option provides an RS-422 serial output to operate a remotely mounted serial display. The format of this serial data is compatible with Gemco displays only. Twenty-five feet of interconnecting cable is included with each display unless additional cable is specified. These displays are available with either 4 or 8 digit readouts and can be mounted up to 600 feet from the programmer. This option is not available when Options A and H are both ordered. Remote serial displays are ordered separately. See wiring diagram E-0211400-B on page 15 for installation details.

Option H - RS-232/485 Transceiver

The RS-232/485 transceiver option is available from a D25 connector located on the top circuit board of the CPU module. This transmitter/receiver allows programmer interrogation and remote programming of all keypad functions via a remote PC, PLC or any ASCII CRT terminal via an RS-232 or RS-485 serial data link. Hardware is provided for both RS-232 and RS-485 operation. Selection of RS-232 or RS-485 operating mode is via a jumper wire mounted on the circuit board. See diagram E-0211400-B on page 15 for wiring details and the supplemental RS-232/485 instruction sheet for details.

VI.

TROUBLESHOOTING

INTRODUCTION

The following procedures are intended to aid in isolating system malfunctions to field replaceable modules. These modules include the display/keypad module, CPU module, output/power supply module, auxiliary output boards, transducer and all interconnecting cables. Once isolated, the defective module should be replaced and returned for factory repair.

Field repair beyond this level is not recommended.

Note: The screw terminals of the CPU module terminal strip do not make electrical contact when not tightened down. Insure that these screw terminals are fully tightened when taking voltage readings.

PRELIMINARY CHECKS

Check all system wiring connections at the transducer, CPU module and output module. Amphenol-type connectors on the transducer and its cabling should be checked for tightness. A slight tug on all wire terminations will verify a good connection. Push-on cable connectors at the keypad, CPU and output modules should be checked for proper connections.

Verify that all wiring at the CPU module is in agreement with its legend plate. The terminal designations of your CPU module may not be identical to the enclosed general wiring diagrams due to the wide range of available options.

Note: Verify that the keypad cable is connected to a multipin connector located through a cutout in the lower left corner of the CPU module's sheetmetal base. Other similar looking connectors may have been used by mistake.

A. Input Operation

A1. Check the operating voltage of the 5 VDC and 15 VDC inputs at the CPU module. Voltage between the terminals labeled 5 VDC (terminals 1 and 2 of terminal strip S2) and ground (terminals 3 and 4 of terminal strip S2) should be 4.8 to 5.2 VDC. This voltage range is critical for proper operation of the microprocessor. Voltage between the terminal labeled 15 VDC (terminal 29 of terminal strip S2) and ground (terminal 30 of terminal strip S2) should be 14.3 to 15.3 VDC. This input powers the transducer excitation circuitry.

If either of these voltages are not present at the CPU module terminals, the input wires should be disconnected and the voltage level checked across the wires. If the correct voltage is seen across the input wires, a short condition probably exists within the CPU module, and it should be replaced.

If the correct voltage levels are not seen across these wires, the power supply has failed. This power supply is located on the top circuit board of the CPU module. An AC line fuse is located on this top circuit board which can be checked by removing the sheet metal cover plate. AC input voltages should be 105 to 125 VAC or 210 to 250 VAC depending on the version specified.

After verifying the AC input voltages and line fuse, the 5 VDC and 15 VDC output should be verified at the power supply with all wiring disconnected at its output terminals. See diagram E-0211300-C, (page 11), for the location of these output terminals.

If the 5 VDC and 15 VDC voltages are now correct at the power supply terminals, an open or short condition of the power supply to CPU module

wiring should be suspected. Incorrect voltages at the power supply indicate a defective power supply and the complete power supply circuit board should be replaced. You will note that this circuit board also holds various optional output circuits that must be specified when a replacement is ordered.

A2. Single-Turn Resolver: AC voltage across terminals 9 and 10 of terminal strip S1 (labeled Red and Bk/R) should be 6.0 to 6.8 RMS. This is the output voltage being supplied to the resolver rotor. If this voltage is not present, disconnect the resolver wires at the CPU module and recheck the voltage. If this voltage is still not present, the resolver excitation circuitry in the CPU module has failed and it should be replaced. If this voltage reappears, a short condition in the resolver or its cable should be looked for.

The return signals from the resolver stator windings wire to the CPU module on terminal strip S1 terminals 12 and 14 (labeled White and Bk/W) and terminals 13 and 15 (labeled Green and Bk/G). To verify the presence of these AC return signals, put a voltmeter across terminals 12 and 14 and rotate the resolver. A voltage reading that rises and falls between these terminals as the resolver is rotated indicates a good resolver return signal. Repeat this same procedure with your meter across terminals 13 and 15. No voltage or a voltage that does not vary as the resolver rotates indicates an open or short condition in the resolver windings or the resolver cable.

The blue resolver wire that connects to the CPU module at terminal strip S1 terminal 21 (labeled BL) was used as a feedback wire on previous Gemco programmable limit switch systems. The presence of voltage on this wire was used to verify that the resolver drive circuitry was operating properly and that resolver cable and resolver windings were not open or shorted.

The Series 1991 PLS has been modified to eliminate the need for this feedback signal to allow the use of resolvers other than those manufactured by Gemco. A small signal transformer has been added to the circuit board and the resolver fault monitoring circuitry has been modified to look for resolver or cable faults based on the signals from this transformer.

Although this feedback wire is not necessary for operation of the system, this terminal is provided to eliminate confusion for customers familiar with previous Gemco PLS systems and eliminate the need for various versions of cable assemblies for the many PLS systems manufactured by Gemco. If your system uses a Gemco resolver assembly and cable,

VI.

TROUBLESHOOTING

PRELIMINARY CHECKS CONT'D.

this wire can be used to assist in pinpointing resolver problems.

A loss of resolver signal will result in all E's displayed across the keypad. This error display can be the result of a failure in the resolver drive circuit, a short or open in the resolver or its cable, or a failure in the resolver monitoring circuit.

A voltmeter across terminal strip S1 terminal 9 (labeled Red) and terminal 21 (labeled BL) should read 6.0 to 6.8 V RMS. If this voltage is not present, but was present across terminals 9 and 10 when checked earlier, an open or short condition exists in the resolver or its cable. If it is present and all E's still appear on the display, a fault in the CPU module resolver monitoring circuitry has been detected and the CPU module should be replaced.

A3. Optional Inputs: There are several options that require a contact closure input to initiate a function. Standard contact closure input terminals are a current source that is taken to ground through the external isolated contact. This external contact can be a mechanical or solid-state switch that can sink 15 VDC at 20ma to the ground of the Gemco CPU module.

These inputs are optically isolated but should not be wired directly to devices in a noisy electrical environment. Electrical noise induced on these input wires can trigger the input. To verify correct operation of these inputs, external wiring should be disconnected at the CPU module and a jumper wire installed between the input terminal and a ground terminal on the CPU module. If the correct response is seen with the jumper wire, the CPU module is fine and a problem in the external wiring or contact should be looked for.

Special inputs that accept a current source are available. A source voltage of 10 VDC to 24 VDC is applied to these input terminals to initiate the function. Any systems having this feature will have a custom part number. Consult the factory for details.

The following is a list of the optional inputs with a description of their intended function. These troubleshooting procedures cover standard current sinking inputs only.

A3a. Multi-Program Selection: These inputs allow the programming and selection of eight different sets of output patterns. Three input terminals on terminal strip S1 labeled BCD1, BCD2 and BCD4 are taken to ground through a BCD selector switch or other device that will simulate the appropriate BCD input. The selected program will be displayed as the far left-hand digit of the digital display. The logic is High = 1 (contact open) which means that nothing wired to these input terminals will result in Program 7 being selected. Jumper wires connect from the 3 BCD input terminals to ground can be used to simulate the proper operation of the BCD switch. One jumper from BCD 1 to ground should result in Program 6 being selected. Jumpers from BCD1 and BCD2 to ground selects Program 4, etc. Proper selection of programs with jumper wires indicates that your problem lies in the external BCD input device or its wiring. BCD selector switches

mounted in high-vibration areas have been known to lose contact continuity momentarily, resulting in sporadic limit switch outputs as the CPU module tries to shift from one program to another. Most software packages allow field selection of multi-program selection via remote BCD switch or via the keypad. Switching to program selection via keypad can help identify problems caused by the remote switch or its wiring. See Multi-programming instructions on page 23 to verify mode selected.

A3b. Reset to Preset: This input resets the digital display and all outputs to a keypad selected number. The wires from this input should not be wired directly to any device in the noisy industrial environment. A relay mounted near the CPU module should be driven by the external reset sensor. The isolated contact of the relay should be wired across the input terminals of the CPU module. If a Gemco relay output module is used as part of your system, the relay module can be purchased with the reset option that provides a solid-state relay for this purpose. A 110 VAC signal from the remote reset sensor is wired to the reset input of the relay output module. The contact of this solid-state relay is wired to the reset terminal of the CPU module through the relay module cable assembly.

A jumper wire used to simulate a reset condition at the CPU module is the best way to verify proper operation of the CPU module itself.

A3c. Latch: Units having an auxiliary binary output may incorporate the latch input option. Upon taking this input low, the auxiliary digital outputs will freeze and will not update until the input is released. This input is used to allow your PLC sufficient time to read this digital data. Upon release, the digital outputs will immediately update to current machine position. The digital display and limit switch outputs are not affected by this input. The display will continue to follow actual resolver position and all limit switch outputs will operate at the appropriate position.

A3d. Buss Enable: This input enables the outputs from the auxiliary binary output terminals. Its intended use is to allow multiple digital outputs to be multiplexed into one PLC input card. The PLC selects the digital input that it wants to look at by taking the appropriate buss enable input low. The buss enable input pin must be taken low to enable any digital outputs. If this option was specified but is not going to be used, a permanent jumper wire should be connected from this input terminal to a ground terminal on the CPU module.

B. Output Operation

B1. CPU Module Outputs: All limit switch, motion detect, up, down and enable outputs will be current sinking, current sourcing or TTL depending on the output type specified by the systems catalog number. See page 19 for the electrical characteristics of these outputs.

When limit switch outputs are programmed, the output status LED's on the keypad will illuminate to indicate when the outputs are supposed to be on.

VI.

TROUBLESHOOTING

PRELIMINARY CHECKS CONT'D.

These LED's only indicate that the microprocessor has signaled the output to operate but they do not verify that the output has responded.

The motion detect output turns on when a keypad selected RPM value is exceeded. The direction output turns on to indicate that the display is counting up and turns off when the display is counting down. The direction output remains in the state based on the last direction of rotation when the resolver stops.

The enable/disable keys on the keypad are used to turn the enable output on or off at terminal strip S2 terminal 6. The enable/disable keys do not affect the operation of the limit switch outputs at the CPU module. If your system incorporates a Gemco relay output module, the enable output at terminal 6 will connect to this relay module and will run the whole relay module ON or OFF when the enable/disable keys are actuated.

To verify the operation of the output drivers test as follows:

B2. Current Sinking (Option E): When it turns on, this output takes the current applied to each output terminal to the CPU module's ground. The ground terminal of the CPU module must be tied to the ground of the current source so that the load sees a completed current flow path when the output is turned on.

Disconnect all wiring from the output terminals being tested to isolate the CPU module from electrical problems outside the module. Connect the positive (+) probe of a DC voltmeter to terminal strip S2 terminal 29 (labeled +15 VDC) and touch the negative (-) probe to each limit switch output in sequence. When the output being tested is ON, you will see 15 VDC at the voltmeter. When the output turns OFF, the 15 VDC signal will disappear. An output that is ON or OFF continuously indicates a defective output driver and the CPU module should be replaced.

B3. Current Sourcing (Option C): Systems having current sourcing outputs will have an input terminal (usually terminal strip S2, terminal 28) labeled +V source. The +V external, customer-supplied DC power supply is wired to this input terminal to provide the current that will be transmitted from the CPU module output driver when the output turns ON. This external power supply should be used only for computer level inputs. Solenoid valves or other noise producing loads sharing this power source can cause sporadic operation or cause damage to the CPU module circuitry.

Disconnect all wiring from the output terminals being tested to isolate the CPU module from electrical problems outside the module. The ground terminal of the CPU module must be connected to the ground of the current source. Connect the negative (-) probe of a DC voltmeter to a ground terminal on the CPU module (terminal strip S2, terminal 30) and touch the positive (+) probe to each limit switch output in sequence. When the output being tested in ON, you will see a voltmeter reading that equals the voltage being applied to the +V

source input terminal from the external power supply. When the output is OFF, this voltage will disappear. Any output that is ON or OFF continuously indicates a defective output driver and the CPU module should be replaced.

B4. TTL (Option T): TTL outputs are wired similar to current sourcing outputs except that there is no +V source input from a remote power supply. In an off condition there will be an internally generated +4.7 to +5 VDC output at each CPU module output terminal in relation to its ground. When the output turns ON, the output driver goes to ground to sink the TTL level signal from the PLC input device into which the signals are being fed. The ground terminal of the CPU module must be connected to the ground terminal of the TTL input device.

To test operation, disconnect all wiring to the output terminals of the CPU module to insure that electrical problems outside the unit do not interfere with its operation. Connect the negative (-) probe of a DC voltmeter to the CPU module ground terminal and touch the positive (+) probe to each output terminal in sequence. When the output is OFF, there will be a +4.7 to 5 VDC signal seen. When the output turns ON, this signal will disappear. Any output that is ON or OFF continuously indicates a defective output driver and the CPU module should be replaced.

C. Gemco Relay Output Modules

Series 1991 relay output modules are used when high-power outputs are required by the loads being driven. The output module takes a 110 VAC or 220 VAC input and generates a 22-24 VDC output for operation of the output relays. This voltage is present at each wire of the cable assembly that connects to a limit switch output on the Gemco CPU module. All relay output modules are intended for use with current sinking (Option E) outputs on the CPU module only. When the CPU module current sinking output turns ON, it sinks the 22-24 VDC output from the relay output module to ground which turns on the high power output relay. All relay output modules have a master enable/disable input that completely enables or disables all relay outputs regardless of the state of the CPU module limit switch output. To test operation of the relay output module, disconnect all wiring of limit switch outputs and the enable output at the CPU module. This insures that problems within the CPU module do not interfere with the testing. Using a jumper wire, connect the yellow wire (output enable) to a CPU module ground or ground wire in the cable assembly and leave this jumper wire in place. The enable LED on the relay output module should turn on to indicate that the output relays are enabled and ready for operation. Next, take a second jumper wire, connect it to a CPU module or cable assembly ground wire and touch it to each limit switch relay output wire in the cable assembly. As each wire is touched, the corresponding output relay on the output module will turn ON. An LED located next to each relay will illuminate to indicate that the relay has been told to turn on. If the

VI.

TROUBLESHOOTING

PRELIMINARY CHECKS CONT'D.

LED illuminates, but the relay does not turn ON, the output relay itself has failed and should be replaced. If the LED does not turn ON, the output module circuitry has failed or there is an open in the cable assembly. To check for an open in the cable assembly, apply jumper wires in the same sequence outlined above except at the multipin connector on the relay output module. If the relay works when jumpered at the relay module connector, but not at the other end of the cable assembly, the cable assembly is defective. If the relay does not operate when jumpered at both locations, the output module circuitry has failed.

An output module relay that is on continuously can be caused by a short in the cable assembly. Disconnect the cable assembly at the relay output module multipin connector. If the relay turns off, the cable assembly wiring is shorted to ground. If the relay remains ON (status LED illuminated) there is a short in the output module circuitry.

D. Output Relays

D1. Mechanical Relays: These relays are rated for loads up to 10 amps at 240 VAC or 10 amps at 30 VDC. A resistor/capacitor noise suppression circuit is located on the circuit board next to each relay socket. This circuit helps suppress electrical noise generated by inductive loads. If the relay is used to control an AC signal into a high impedance load, leakage in this RC noise suppression circuit may turn the load on even when the relay contact is open. Typical loads that may not operate properly due to this leakage include 110 VAC PLC input cards and very small control relays. To eliminate this problem, the capacitor can be removed from the RC network protecting the relay having the control problem. The capacitor is labeled C1 preceded with a prefix number that correlates it to a specific output relay.

Example: Capacitor 8C1 is part of the RC network protecting output relay number LS8.

When using this relay for driving inductive loads like solenoids, a noise suppression device *must* be installed across the coil of the load. Use an MOV or RC noise suppressor for AC loads, or a commutating diode for DC loads.

Note: A solid state relay output module may contain both AC and DC solid state relays. AC relays will be black and DC relays will be red. Insure that the correct type of relay is being used for the load being driven.

D2. AC Solid-State Relays: These triac output relays are rated for loads up to 3 amps at 280 VAC. Current leakage is 5ma at 280 VAC. This may be sufficient leakage to improperly turn on high impedance loads like PLC input cards or very small control relays. If leakage appears to be causing improper operation of your load, an 18Kohm 2 watt load resistor wired from the relay output to ground will generally eliminate the problem. Special low leakage relays are available. Consult the factory for details.

The standard triac relay is a zero crossing type

relay which produces much less electrical noise than a random turn-on device. However, premature triac failure may result if it is used in a control circuit in which other control contacts are paralleled around the triac. If this paralleled contact opens and closes while the triac is turned off, transients may be generated that will damage the triac. Sporadic operation can also result if the triac is turned on while the paralleled contact is closed. A triac needs current flow to turn on which will not be available when the paralleled contact is closed.

It's recommended that an MOV or RC noise suppression device be installed across the coil of any inductive device, such as solenoids, that are being driven by our triac output relay.

D3. DC Solid-State Relays: These high-power open collector solid-state relays are rated for loads up to 3 amps at 60 VDC. The polarity of the load current *must* be wired through this relay per diagram E-0213001-A on page 14 of this manual.

When using this relay to drive an inductive load like a DC solenoid, a commutating diode must be installed across the coil of the solenoid to eliminate high voltage spikes.

E. Electrical Noise and Power Quality Considerations: This system is designed for use in an industrial environment and incorporates extensive transient suppression circuitry. However, the same general installation rules should be followed that apply to all microprocessor-based equipment.

Problems that can be attributed to extreme electrical noise or poor power quality include loss of, or changes in, program memory, loss of microprocessor initialization, keypad/microprocessor lock-up, sporadic outputs and damage to resolver drive circuits, auxiliary input circuits and output driver circuits.

E1. Grounding: Circuit board level noise suppression circuits, ground planes and cable shields all depend on a good earth ground for proper operation. Our field experience has shown that the quality of the service ground at many machines is marginal.

E2. Incoming Power: Solenoids, welders, large motors and variable-speed drives are all devices that generate excessive electrical noise throughout the power grid in a typical industrial environment. Isolation transformers or constant voltage type power supplies should be used to isolate microprocessor-based circuitry. The power on the output side of these isolation devices should be fed to the programmable limit switch and other microprocessor-based devices only. The loads being driven by the programmable limit switch output relays *must not* get their power from the output side of the isolation device. Using the output side of an isolation device to power loads other than the programmable limit switch totally defeats the purpose of the isolation device.

If an isolation device is used to provide AC power to the Series 1991 PLS, *do not* jumper this same power from the AC input terminals of the relay module to its output relays. Power for the output

**PRELIMINARY
CHECKS
CONT'D.**

relay loads should come from the input side of the isolation device or some other totally separate power source.

The 5 VDC and 15 VDC power generated by the CPU module power supply should not be used to power any auxiliary device.

E3. Low-Level Inputs: Low-level inputs to the Gemco CPU module include the resolver cable and other special purpose contact inputs like reset to preset, latch and multiprogram selection.

The resolver should be wired to the CPU module using an uninterrupted run of cable consisting of twisted pairs with shields. Whenever possible, this cable should be run in a conduit by itself. If it must run in a conduit with other wiring, this other wiring should not include power wires above 110 VAC or wires driving noise producing loads.

If the resolver cable must be run through a terminal strip, it must be mounted in a small enclosure with no other wiring. The shields of the incoming and outgoing cable must be tied together and isolated from ground.

Special-purpose contact inputs all operate by connecting the input pin on the CPU module to a ground terminal on the CPU module through a remote contact or solid-state switch. These computer level signals must be protected from induced electrical noise. The contact used to activate the input should not be located outside the enclosure in which the Gemco CPU module is mounted. Any wiring between the CPU module input terminals and this contact located within the enclosure should be routed away from any power handling relays, contactors or other noise generating devices.

If the input is to be activated by a remote device, the contact of the remote device should be used to energize a relay within the enclosure. The contacts of this relay are wired to the CPU module input terminals.

E4. Outputs: The low power outputs from the Gemco CPU module are intended for use with a PLC input card, a Gemco relay output module or a solid-state relay board compatible with the low-power output. It's not recommended that these outputs be used to drive an inductive load like the small DC relay. If an output must be used for this purpose, care must be taken to insure that the relays inrush current does not exceed the outputs rating and a commutating diode *must* be installed across the relay's coil to eliminate electrical spikes.

Any DC power supply used for sinking or sourcing outputs to a PLC input card should be used for this purpose only. This power supply should not be used to drive any inductive loads.

The high-power relays on a Gemco relay output module or relay module supplied by others can generate excessive electrical noise if used to drive inductive loads. Noise suppression devices must be installed across the coil of these loads as described on page 29. The power fed to these contacts must not come from the conditioned side of any isolation transformer or power conditioner used to power the programmable limit switch.

VI.

TROUBLESHOOTING GUIDE

SYMPTOM	POSSIBLE CAUSES
Display shows all E's.	Resolver disconnected, resolver cable problem or excitation circuitry failure. See input operation troubleshooting sections A1 and A2, page 26. If CPU excitation failure is found to be the cause of problem, review section E through E3, pages 29-30 concerning electrical noise problems.
Display shows all P's.	Loss of microprocessor initialization. The initialization code number is programmed at the factory and should never be field-changed or lost. This code number establishes the locations in memory that the microprocessor looks for data and is specific to the software number and part number of the system. See the part number descriptor sheet supplied with the system for the correct initialization code and re-enter on the keypad. Loss of initialization code indicates a severe power fluctuation or electrical noise. Review section E through E3, pages 29-30 if this condition reoccurs.
All relay output module outputs inoperative.	All output relays on a Gemco relay module are turned on or off by the enable/disable button on the keypad. When enabled, the enable LED on the relay module will be illuminated. Verify that enable button has been depressed and that enable LED on keypad and enable LED on relay module are illuminated. See section C, page 28 for troubleshooting details.
An individual high-power output relay on output module does not operate, but status light on keypad indicates proper operation.	Output relay failure. If relay status LED on output module operates but relay doesn't turn on, relay may have failed. Replace relay and/or check output fuses on solid state relay. A PLC input card or small relay being fed by our output relay may remain on when our relay is off due to leakage in the relays noise suppression circuit. See section D through D3, page 29 for details and notes on relay wiring diagrams on page 14. Review section C, page 28 for details on isolating the problem to the CPU module, cable assembly or relay output module.
An individual low-power output from the CPU module does not operate but status LED on the keypad indicates proper operation.	Output driver failure. Review section B through B4, pages 27-28 for troubleshooting details. If this is a reoccurring problem, review section E4, page 30 for possible installation problems.
System operates properly but exhibits a random momentary loss of all outputs.	Random momentary loss of all power to the system. A loss of power for as short a duration as 50 milliseconds will cause the system to shut down. When power is reapplied, the system can take several seconds to reinitialize itself. During this time period, all outputs are disabled. This intermittent loss of power could be caused by a bad terminal strip connection, bad relay contact, application of a very large motor load or momentary loss of incoming plant power. Momentary loss of continuity in the multi-program selector switch on multi-program systems. The selection of program is accomplished by a BCD switch or relay logic wired from these inputs to ground. Any momentary loss of these inputs will be read as a program change resulting in all outputs being inhibited as the new output patterns are compiled in memory. High vibration where the selector switch is mounted or bad contacts on the switch or logic relays should be looked for. Review section A3 and A3a, page 27 for details.
Mechanical output relays operate sporadically.	Low AC power supplied to relay output module. The mechanical output relays can become more sensitive to low input power as additional relays energize. When using mechanical relay output modules, the incoming AC voltage should be 110 VAC minimum. Review sections C, D and E on pages 28-29 for other causes.
Keypad displays meaningless data. Outputs may or may not operate properly.	System mounted in a high-shock or vibration area causing intermittent electrical connections. System operating in a high-electrical noise environment. Review installation instruction concerning routing of cables on page 9. Review general electrical noise considerations under troubleshooting section E on page 29. Keypad ribbon cable connected to wrong mating connector on CPU module. Correct connector is 14 pin connector accessed through cutout in lower left corner of sheetmetal base. See general wiring diagram E-0211300-C on page 11-12 for location.

VI.

TROUBLESHOOTING GUIDE

SYMPTOM	POSSIBLE CAUSES
The display and outputs lose synchronization with machine position.	<p>If the reset to preset option is being used, electrical noise on the wiring to this input can cause unwanted resets. Also, all resets triggered by the use of this input will be lost on a power failure. Preview page 9 and troubleshooting section A3b, page 27 concerning the proper use and installation of this option.</p> <p>A gradual reoccurring loss of synchronization is generally caused by slippage in the mechanical couplings to the resolver. Verify the mechanical integrity of couplings, sprockets, chains, etc. that are in the drive train to the resolver's input shaft. The resolver assembly uses a small, internal flexible coupling to connect its input shaft to the resolver, mounted inside the assembly. Disassemble the resolver and verify the tightness of the coupling screws.</p>
Nonsequential count on digital display.	<p>A programmed scale factor that is larger than the system's resolution will result in counts being skipped. The location of the skipped counts will be spread evenly over the full scale factor. Verify the programmed scale factor by pressing the scale factor button on the back of the keypad. If it is larger than 4096, counts will be skipped.</p> <p>An open or shorted condition in the resolver secondary coil or cable will result in the display jumping the equivalent of 25% of the scale factor.</p>
System will not accept programming instructions.	<p>Verify that keyswitch is in program position. Verify that the programming sequence is being followed exactly. Omission of the "ENT" key in all required locations is a common mistake.</p> <p>Flashing decimal points indicate multiple set points on the selected circuit. To see all settings, continue to press the "CIR ON" or "CIR OFF" key until all set points have been displayed.</p> <p>Verify that both ends of the keypad to CPU module cable assembly are fully inserted.</p> <p>If the membrane keypad fails, it is usually due to a shorted condition under one of the keys. If the digital display locks on some random number during programming and cannot be cleared by powering the system down, suspect a keypad failure.</p>
Set points not firing at programmed position.	<p>Probably due to programming errors. Flashing decimal points on the display indicate that multiple set points are programmed on the selected circuit. After calling up a circuit, continue pressing the "CIR ON" or "CIR OFF" key to view all set points held in memory. Many programmers think they have changed a set point location but have really added another set point on the same circuit.</p> <p>Any circuit that has a programmed OFF setting without corresponding ON or an ON without corresponding OFF will change state when the position passes through zero. Review programming instructions in section IV, page 20-22.</p> <p>Leakage in the noise-suppression circuits of the high power solid state relays and mechanical relay noise suppression circuits may cause sporadic operation of high impedance loads. See troubleshooting sections D1 and D2, page 29 for details.</p>

NOTES

PATRIOT

Sensor Solutions

Patriot Sensors & Controls Corporation • 1080 N. Crooks Road • Clawson, MI 48017
800-635-0289 • 248-435-0700 • Fax 248-435-8120 • www.patriotsensors.com

1991.M1
3/99 • Z22