

Series 953



## INSTALLATION MANUAL

LINEAR DISPLACEMENT TRANSDUCERS

# 953A VMAX™

Linear Displacement Transducer



**ABSOLUTE PROCESS CONTROL  
KNOW WHERE YOU ARE... REGARDLESS**

## Contents

<b>Chapter 1: 953A Overview</b> .....	<b>2</b>
<b>Chapter 2: Installing</b> .....	<b>4</b>
2.1 Installing to a Mounting Bracket .....	4
2.2 Installing in a Hydraulic Cylinder .....	5
<b>Chapter 3: Wiring</b> .....	<b>8</b>
3.1 V0/V1 (Voltage) .....	8
3.2 C4/C2 (Current) .....	8
3.3 Setting Zero & Span Position .....	12
<b>Appendix A: Troubleshooting</b> .....	<b>13</b>
<b>Appendix B: Part Numbering</b> .....	<b>14</b>
<b>Appendix C: Specifications</b> .....	<b>15</b>

**NOTE:** Ametek has checked the accuracy of this manual at the time it was approved for printing. This manual may not provide all possible ways of installing and maintaining the LDT. Any errors or additional possibilities to the installation and maintenance of the LDT will be added in subsequent editions. Comments for the improvement of this manual are welcome.

Ametek reserves the right to revise and redistribute the entire contents or selected pages of this manual. All rights to the contents of this manual are reserved by Ametek. VMAX is a registered trademark of Gemco.

### Unpacking

Carefully remove the contents of the shipping carton and check each item on the packing slip before destroying the packing materials. Any damage must be reported to the shipping company. If you do not receive all of the parts, contact Ametek at 800-635-0289 (US and Canada) or 248-435-0700 (International).

Most probes are shipped in a Tube. To remove the metal end cap, use a large, flat blade screw driver or a metal rod and tap on the inner edge of the cap until it pivots. Grab the cap and pull it out. Use caution as the edge of the metal cap may be sharp.

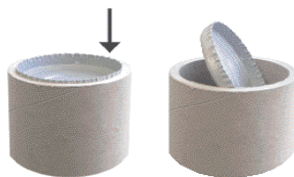

If you have an RMA warranty claim, pack the probe in a shipping tube or with stiff reinforcement to prevent the probe from being bent in transit.

## Chapter 1: 953A Overview

The 953A VMAX is a magnetostrictive Linear Displacement Transducer (LDT) for highly accurate continuous machine positioning in a variety of industrial applications.

This sensor is built to withstand the most severe environmental conditions and is completely absolute. This means that power loss will not cause the unit to lose position information or require re-zeroing. The non-contact design allows this device to be used in highly repetitive applications without mechanical wear.

The 953A VMAX has a few truly unique features. One feature is the LDT's auto-tuning capability, the ability to sense a magnet other than the standard magnet and adjust its signal strength accordingly. Another feature is that the analog output is programmable over the entire active stroke length. The active stroke area lies between the Null Zone and Dead Band.

There is a diagnostic LED located at the connector end of the probe that remains green while a good magnet signal is present and when the magnet is in the programmed stroke area. The LED turns yellow when the magnet is out of the programmed active range, but still within the active stroke area. The LED turns RED if there is a loss of magnet and the output will go to 0 volts on a voltage unit and 3.8mA on current model units.

The 953A VMax LDT with a 4 to 20mA output offers a unique diagnostic capability. The normal 4 to 20mA output indicates the position of the magnet within the programmed span. If the position of the magnet is outside the set span, the output is either 3.9mA or 20.1mA. If the magnet moves into the Null or Dead Zones or there is a loss of magnet the output will be 3.8mA. This feature is only available on units with a current output. On voltage units the voltage output will be 0 volts below the programmed zero point and 10volts above the programmed Span.

All units can easily be changed in the field from a 0-10VDC to a 10-0VDC or a 4-20mA to a 20-4mA.

**NOTE:** The part number on the LDT is a record of the characteristics that make up your specific unit. For a translation of the part number, see Appendix B.

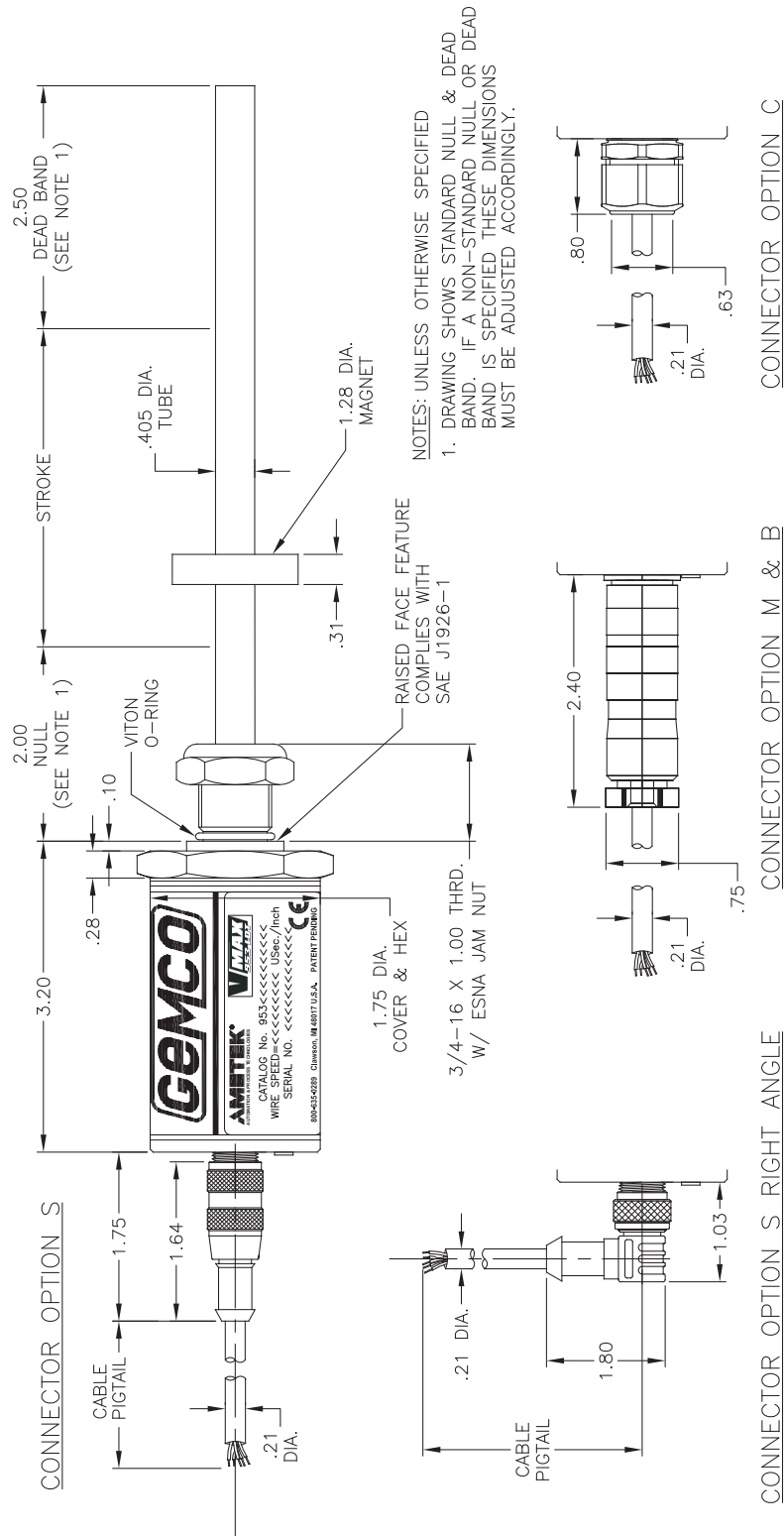

Figure 1-1 953A Dimension Drawing



## Chapter 2: Installing the LDT

If a mounting bracket or other part is used that is made of ferromagnetic material (a material readily magnetized), it should be placed no closer than 0.25" from the LDT's rod end to minimize the effects of magnetic flux distortion. This can cause an inaccurate measurement of the magnet position.

Non-ferrous materials, such as brass, copper, aluminum, non-magnetic stainless steel, or plastics, can be in direct contact with the magnet assembly and rod end without producing any adverse results.

### 2.1: Installing the LDT to a Mounting Bracket

Parts discussed in this section can be found in Figures 1-1 and 2-1.

1. Unscrew the LDT's jam nut from the threads protruding from the hex mounting base.
2. Insert the LDT's rod end into the mounting bracket's hole. The mounting bracket may contain a 3/4-16 UNF-2B threaded hole. In this case, screw the LDT into this hole using the threads protruding from the hex mounting base.
3. Once the LDT is in place, screw the jam nut back onto the threads of the hex mounting base. Use the 1.75" hex mounting base on the head assembly to tighten the LDT to the bracket.



**WARNING:** Do not use the blue aluminum cover of the head assembly to tighten the LDT within the bracket (see Figure 2-1). This may damage the LDT and will void your warranty. To tighten the LDT within the bracket, use the 1.75" hex mounting base on the head assembly.

If the length of the LDT's rod end is less than 30", skip to the sub-section: Mounting the Magnet Assembly.

#### Installing Support Brackets

It is recommended that a support bracket be used

with LDTs having a rod 30"-71" in length. Supporting the end of the rod will minimize operational errors and protect against damage due to shock and vibration. If the length of the LDT's rod is 72" or longer, it is recommended that additional support brackets be used. These additional support brackets must be made of a non-ferrous material. Because these additional support brackets will interfere with the magnet's movement, a special split-type magnet assembly must be used. To order a split magnet (P/N SD0411200) and support brackets (P/N SD0411100), contact the factory at 800.635.0289.

To install a support bracket for an LDT having a rod 30"-71" in length, perform step 4a. If the rod is longer than 71", perform step 4b.

- 4a. If the support bracket is made of a ferromagnetic material (material readily magnetized), install the support bracket no closer than 0.25" from where the LDT's dead band ends and the area of stroke begins. Continue to the sub-section: Mounting the Magnet Assembly.

To install two or more support brackets for a LDT having a rod 72" or longer in length, perform the following steps:

- 4b. Install support brackets at increments of 48" throughout the LDT's rod. Support brackets placed within the Null Zone and area of stroke or closer than 0.25" to the beginning of these areas must be made of a non-ferrous material.

#### Mounting the Magnet Assembly

Before mounting the magnet assembly, the following should be considered:

- Ferromagnetic material should not be placed closer than 0.25" from the LDT's magnet assembly or rod end. Failure to do so could cause erratic operations.
- Minimal clearance between the LDT's rod and the magnet assembly through the full stroke is

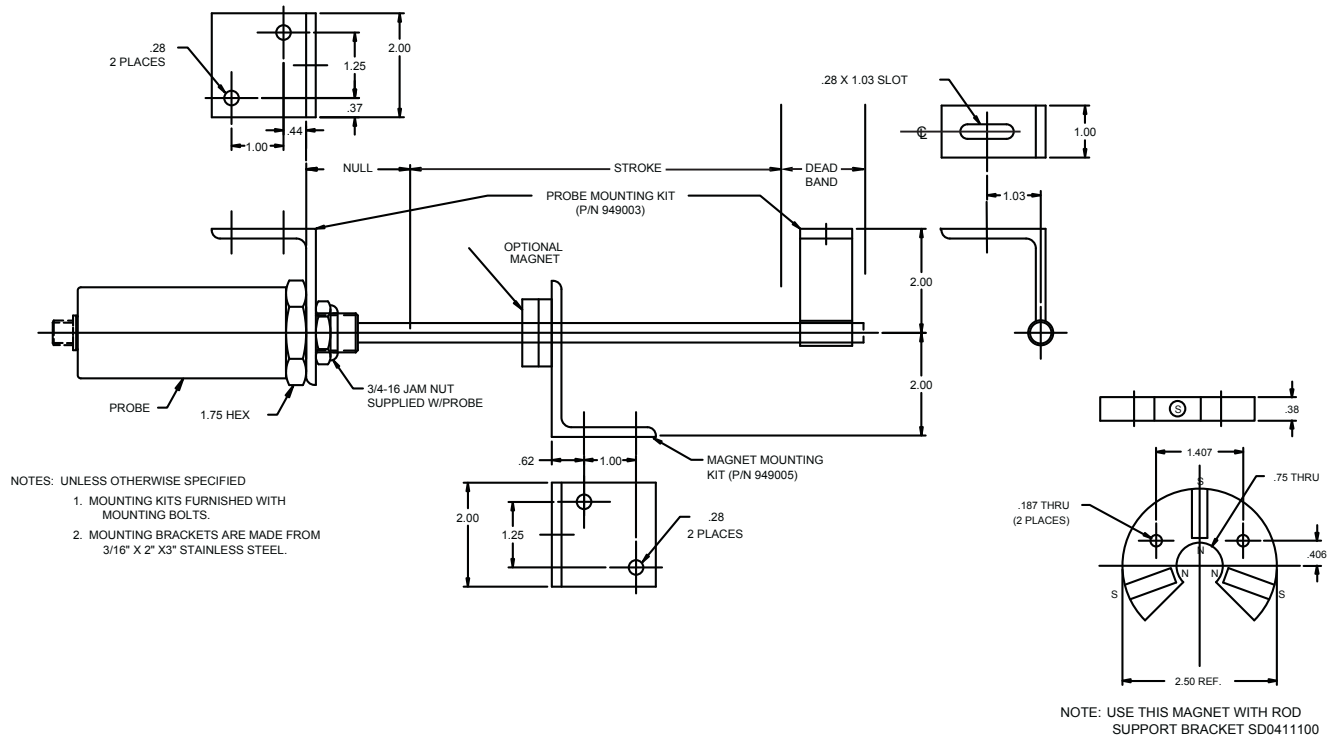

Figure 2-1: Mounting the LDT

required. Stress between the magnet and the rod can cause flexing of the mounting brackets. This may result in non-linearity.

- LDTs using a split magnet assembly must keep the diameter of the magnet assembly around the rod throughout the complete stroke. The diameter of this magnet assembly should not be more than 0.2" away from the rod. Split magnet assemblies outside of this range will cause signal loss.

To install the magnet assembly, perform the following steps:

1. Slide the magnet assembly over the LDT rod.
2. Mount the magnet to the non-ferrous, movable portion of the device being controlled using non-ferrous screws.

## 2.2: Installing the LDT in a Hydraulic Cylinder

Before installing an LDT in a hydraulic cylinder, note the following considerations. Items discussed in this section are found in Figures 1-1 and 2-1.

- A non-ferrous spacer must be used to separate the magnet assembly from the head of the piston rod. See Figure 2-2.
- The magnet should not be closer than 2.0" from the base of the LDT's hex head when the piston rod is fully retracted. In instances where space restraints exist, it may be required to countersink the magnet into the piston rod. Two magnets are available for mounting to the piston: the standard 1.29" in diameter (P/N SD0400800) four-hole magnet and the 1.0" magnet (P/N SD0410300) designed exclusively for countersunk mounting applications. The 1.0" magnet must be secured with a snap ring.





- An O-ring is provided at the base of the LDT's mounting hex for pressure sealing. The O-ring seal was designed to meet Mil-Std-MS33656. Refer to SAE J514 or SAE J1926/1 for machining of mating surfaces.
- A chamfered rod bushing in front of the magnet may be required. It is recommended that a chamfered rod bushing be used with LDTs having a rod 60.0" or longer. This bushing will prevent wear on the magnet assembly (wear occurs as the piston retracts from extended lengths). This rod bushing should be manufactured from a high wear polymer, such as Teflon®.
- It is recommended the bore for the cylinder piston rod have an inside diameter of at least 0.50". The LDT rod has an outside diameter of 0.405". Use standard practices for machining and mounting these components. Consult the cylinder manufacturer for details on applicable SAE or military specifications.

It may be necessary to perform machining and mounting operations on the hydraulic cylinder before installing the LDT. Consult the information and specifications provided by the cylinder manufacturer before beginning the following steps:

1. Unscrew the LDT's jam nut from the threads protruding from the hex mounting base.
2. Position the non-ferrous spacer against the piston face, followed by the magnet, and then the chamfered rod bushing if the LDT's rod is 60.0" or longer in length.
3. Insert non-ferrous screws through the chamfered rod bushing (if used), magnet, and non-ferrous spacer. Secure items by tightening screws.

If the leading edge of the magnet will come closer than 2.0" from the base of the LDT's hex head when the piston rod is fully retracted, it will be necessary to counterbore the magnet assembly into the piston rod. Both the standard 1.29" four-hole magnet assembly (P/N SD0400800) and the 1.0" magnet assembly (P/N SD0410300) are designed for counterbored mounting applications. If it has a 1.0" magnet assembly, a snap ring will be needed to hold it in place.

4. Insert the LDT's rod into the hole of the hydraulic cylinder's mounting bracket.

The protective Plug may need to be removed from the hydraulic cylinder before inserting the LDT. The end cap should contain a 3/4-16 UNF-2B threaded hole. Screw the LDT into this hole using the threads protruding from the LDT's hex mounting base.



**WARNING:** Do not use the blue aluminum cover of the head assembly to tighten the LDT within the bracket (see Figure 2-1). This may damage the LDT and will void your warranty. To tighten the LDT within the bracket, use the 1.75" hex mounting base on the head assembly.

With the LDT properly installed inside the hydraulic cylinder, it may be necessary to assemble parts of the hydraulic cylinder. For assistance in this task, refer to the information provided by the cylinder manufacturer.

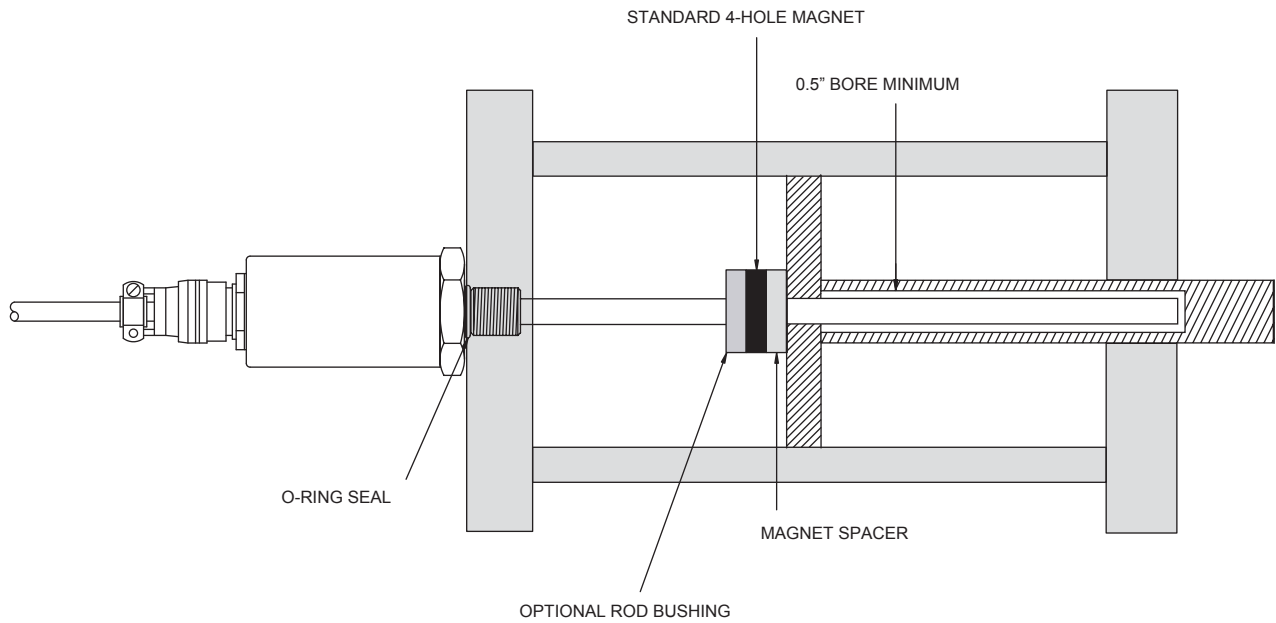
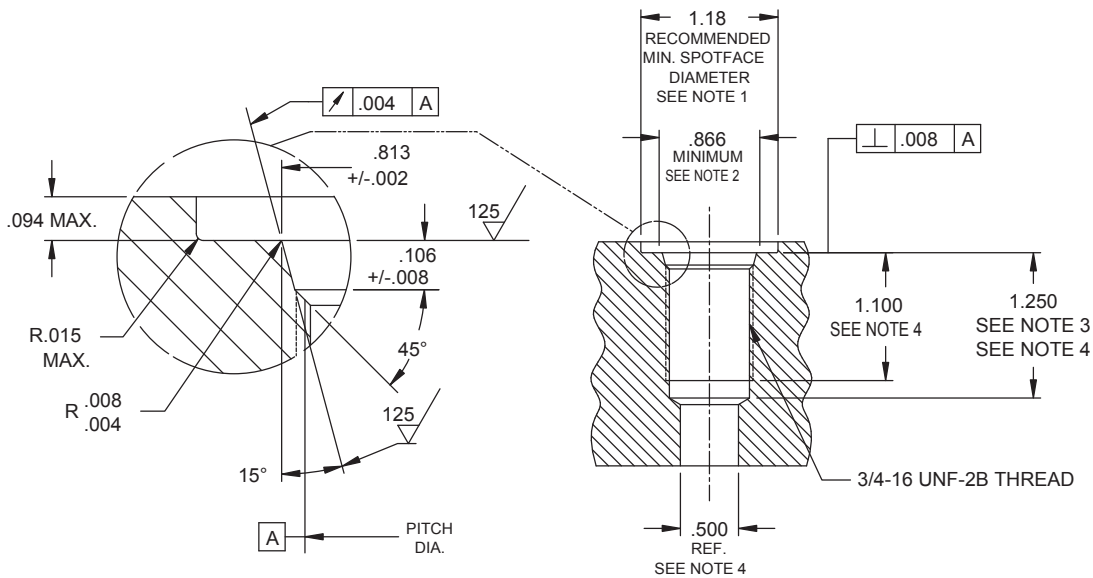

Figure 2-2: Mounting LDT in a Hydraulic Cylinder



NOTES:

1. IF FACE OF PORT IS ON A MACHINED SURFACE, DIMENSIONS 1.180 AND .094 NEED NOT APPLY AS LONG AS R.008/.0004 IS MAINTAINED TO AVOID DAMAGE TO THE O-RING DURING ASSEMBLY.
2. MEASURE PERPENDICULARITY TO A AT THIS DIAMETER.
3. THIS DIMENSION APPLIES WHEN TAP DRILL CANNOT PASS THROUGH ENTIRE BOSS.
4. THIS DIMENSION DOES NOT CONFORM TO SAE J1926-1.

Figure 2-3: Port Detail (SAE J1926/1)

## Chapter 3: Wiring

Once the LDT has been installed, wiring connections can be made. The VMAX has four different connector options. Please refer to the part number label to help identify which wiring diagram is correct. There are two groups of connections that will need to be made. They are as follows:

- Power Supply Connections (including grounding and shielding)
- LDT Input/Output Connections

**Power Supply/Ground Connections**  
Connector option S is an industry standard 5 pin 12mm Euro style cordset with a shield. Option B is an 8 pin DIN with a shield, and option M is a 6 pin DIN with a shield. To reduce electrical noise, the shield must be properly used. Connect the cable's shield to the controller system GND. The cable shield is NOT connected at the transducer rod. Always observe proper grounding techniques such as single point grounding and isolating high voltage (i.e. 120/240 VAC) from low voltage (7-30 VDC cables).



**WARNING:** Do not use molded cordsets with LEDs!

It is preferable that the cable between the LDT and the interface device be one continuous run. If you are using a junction box, it is highly recommended that the splice junction box be free of AC and/or DC transient-producing lines. The shield should be carried through the splice and terminated at the interface device end.

**NOTE:** When grounding the LDT, a single earth ground should be connected to the Power Supply Common (circuit ground). The LDT Power Supply Common should be connected to the Power Supply Common (-) terminal. The LDT power supply (+VDC) should be connected to the power supply positive terminal (+). The LDT cable shield should be tied to earth ground at the power supply. The LDT analog common should not be connected to earth ground and should be used for connection to interface devices only. For assistance, refer to your LDT's wiring drawing in this chapter.

In order for the VMAX to operate properly, the external power supply must provide a voltage between 7-30 VDC. The power supply must be rated at one watt minimum. The power supply should provide less than 1% ripple with 10% regulation.



**WARNING:** Do not route the VMAX cable near high voltage sources.

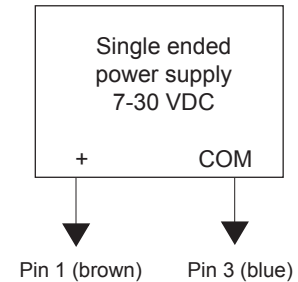

Figure 3-1: Power Supply Wiring

**The power supply should be dedicated to the VMAX to prevent noise and external loads from affecting it. When powering up more than one VMAX on a single power supply, each unit will draw approximately one watt.**

### 3.1: V0/V1 (Voltage)

The LDT generates a voltage output based on position. The 953 VMAX offers 16 Bits of resolution, and is fully programmable over the entire active stroke length. Keep in mind that there is a 2" Null Zone at the connector end of the LDT and a 2.5" Dead Band at the other end of the LDT that the magnet must stay out of at all times. The units come fully programmed from the factory and do not require re-programming unless desired.

The analog output is referenced to the analog common terminal and should not be referenced to any of the other common terminals. For wiring, see Figure 3-2. For programming Zero and Span, See Section 3.3.

### 3.2: C4/C2 (Current)

The LDT generates a current output based on position. The 953 VMAX offers 16 Bits of resolution, and is fully programmable over the entire active stroke length of the LDT. Keep in mind that there is a 2" Null Zone at the connector end of the LDT and a 2.5" Dead Band at the other end of the LDT that the magnet must stay out of at all times. The units come fully programmed from the factory and do not require re-programming unless desired.





### Typical Wiring

Figure 3-2 shows two common methods for wiring the 953A to a customer supplied interface device, such as a PLC or panel meter. The two different methods are commonly referred to as Single Ended Input or Differential Input. Differential Input is the preferred wiring method.

With the Differential Input, the Analog Common wire is connected to the customer supplied input device and the Power Supply Common is wired separately to the customers supplied power source. When wired using the Differential method, the electrical noise and voltage offset errors produced by the currents running through the Power Supply Common are eliminated. The Power Supply Common and Analog Common are internally connected inside of the 953A VMAX LDT.

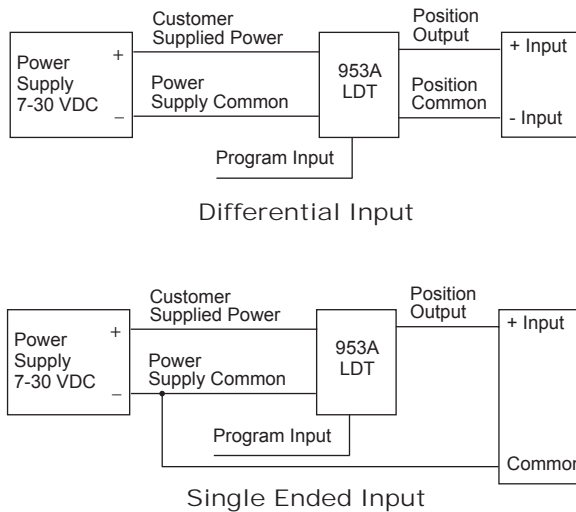

Figure 3-2: Current Sourcing

The 953A-C is current sourcing which allows the current to flow from the LDT into the users equipment.

Diagnostic LED	
LED Color	Description
None	No power to LDT
Green	Magnet signal detected and within programmed range.
Yellow	Magnet signal detected, but magnet is outside of programmed range. <b>NOTE:</b> Magnet can be programmed in this range if desired.
Red	No magnet signal detected. Make sure magnet is on the rod and within the active area. Move magnet back into the range and cycle power.

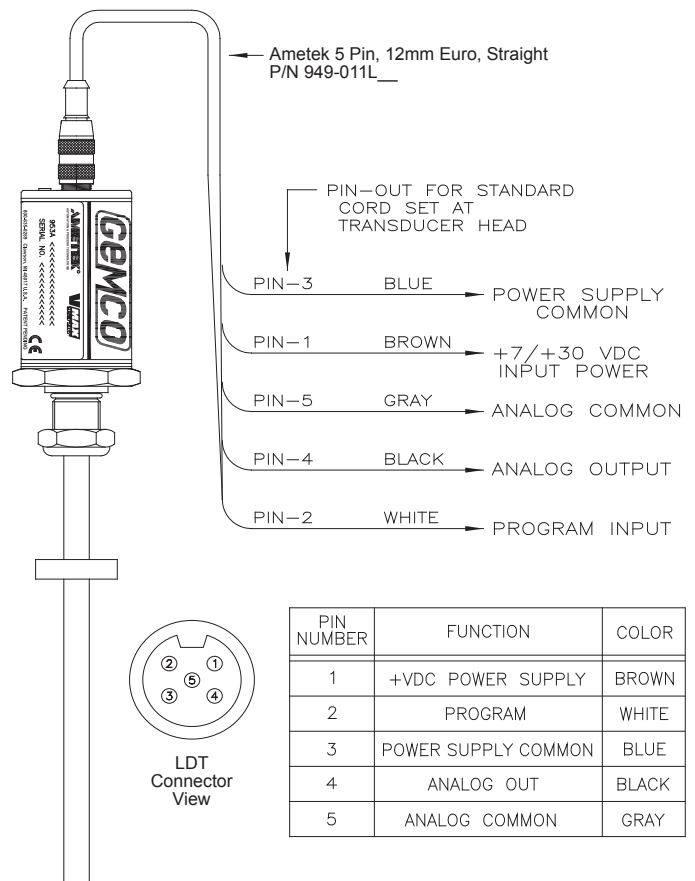

Figure 3-3: Wiring for Connector Option "S", 5 Pin Micro

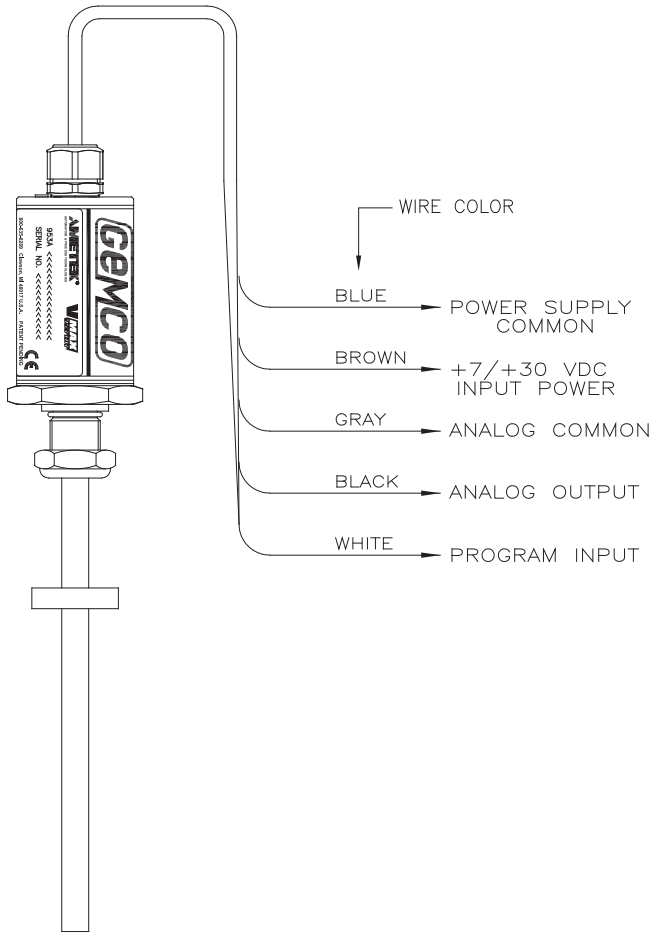

Figure 3-4: Wiring for Connector Option "C", Integral Cable Assembly

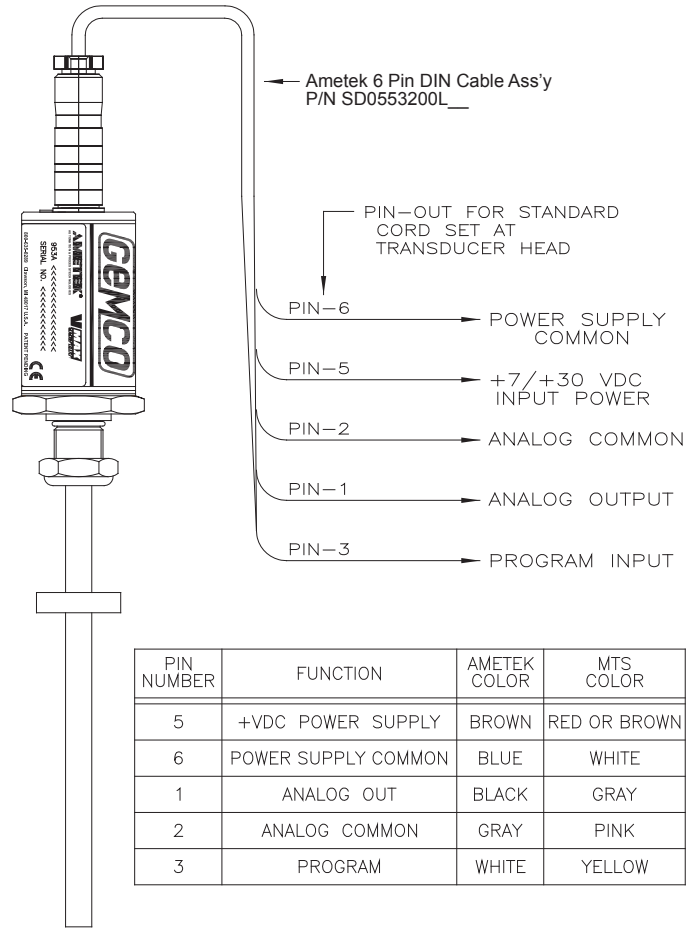

Figure 3-5: Wiring for Connector Option "M", 6 Pin DIN

PIN NUMBER	FUNCTION	AMETEK COLOR	MTS COLOR
5	+VDC POWER SUPPLY	BROWN	RED OR BROWN
6	POWER SUPPLY COMMON	BLUE	WHITE
1	ANALOG OUT	BLACK	GRAY
2	ANALOG COMMON	GRAY	PINK
3	PROGRAM	WHITE	YELLOW

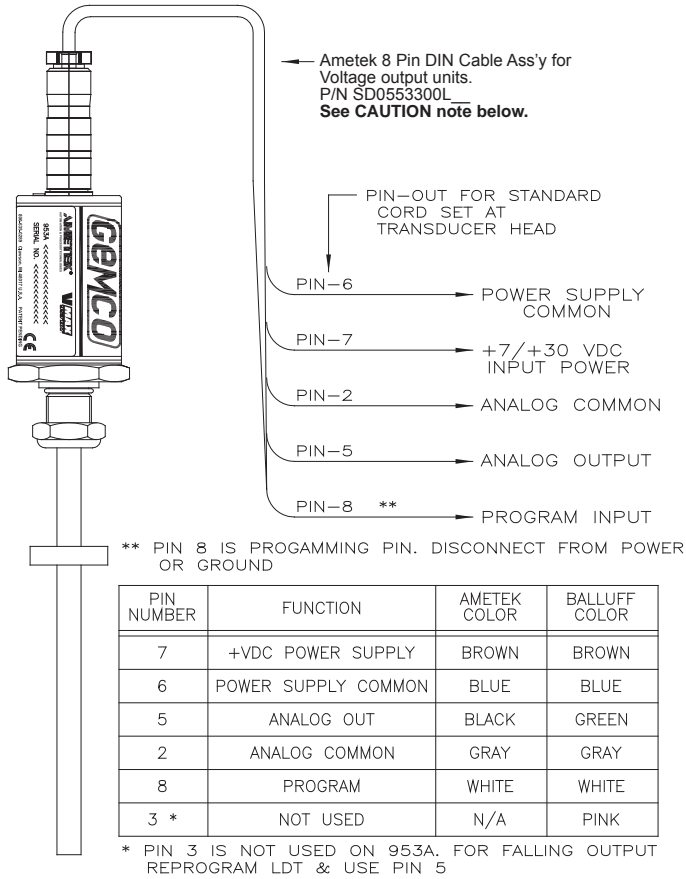

Figure 3-6: Wiring for Connector Option "B", 8 Pin DIN, Voltage Output

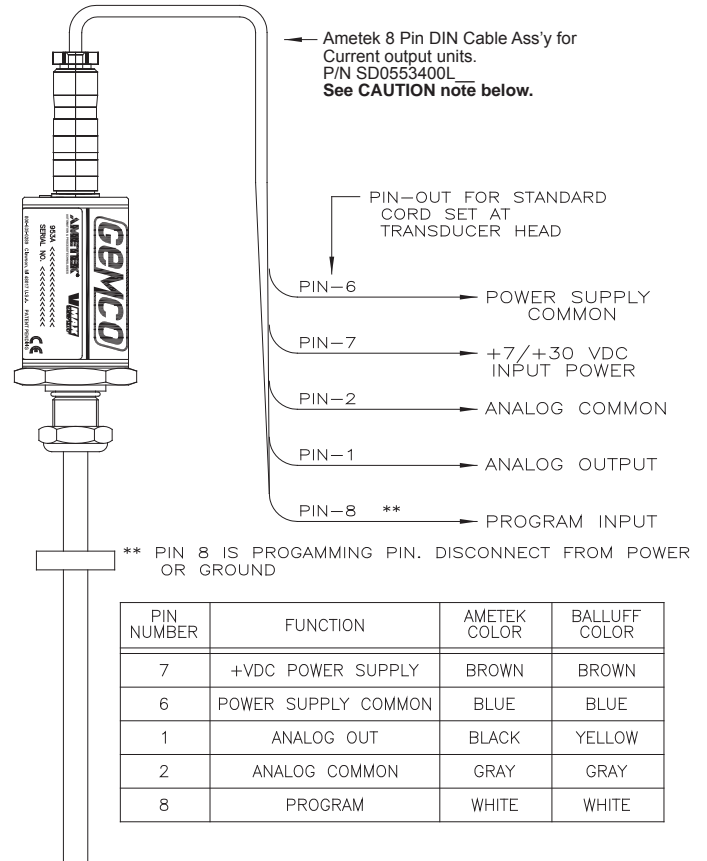

Figure 3-7: Wiring for Connector Option "B", 8 Pin DIN, Current Output



CAUTION: Pinout is different for voltage vs. current models with connector option "B"

## 3.3: Setting Zero & Span Position

The units come fully programmed from the factory and do not require re-programming unless desired. The units are 100% absolute and will not lose programmed parameters on power loss. The Zero and Span points can be programmed in any order and anywhere within the LDT's active sensor area.

**NOTE 1:** Zero or Span can be adjusted individually without setting the other.

**NOTE 2:** Zero = 0V on 0-10 VDC units and 4mA on 4-20mA units.

There is a timing sequence that is used to unlock the probe for programming. This is to insure that the Span cannot be accidentally re-programmed by someone in the field.

Before programming the Zero or Span, the program input must be connected to the Power Supply Common for a minimum of 2 seconds and no more than 6 seconds, then released for 1 second. The LTD programming sequence is now unlocked and will remain an unlocked unit until either the Zero or Span is programmed or the 10 second programming sequence times out. During the unlock mode either the Zero or Span can be programmed by momentarily connecting the Program Input to either the Power Supply Common or Power Supply +.

**NOTE:** The LDT must be unlocked to program the Zero and unlocked again to program the Span. Once either the Zero or Span is programmed the LDT will go back into the locked mode.

To program the Zero or Span, the program input must be connected to the Power Supply Common for 4 seconds, then released for 1 second. Within the next 5 seconds, you can program either the Zero or the Span by momentarily connecting the Program Input to either the Power Supply Common or Power Supply +VDC.



**WARNING:** During normal operation, electrically insulate the White Program wire to prevent accidental setting of Span.

## Manual Setting of Zero & Span

To set the Zero and Span position, follow these steps:

1. Apply power to the LDT.
2. Place magnet assembly where Zero is to be located, but within the active region of the probe.
3. Short the Program Input pin to the Power Supply Common for 4 seconds. Remove the short for 1 second. Within 5 seconds, short the Programming Input pin to the Power Supply Common. This completes the Zero programming process.
4. Place magnet assembly where Span is to be located, but within the active region of the probe.
5. Short the Program Input pin to the Power Supply Common for 4 seconds. Remove the short for 1 second. Within 5 seconds, short the Programming Input pin to the Power Supply +VDC.

This completes the programming process.

## Optional Remote Tester & Programmer

The battery operated remote tester / programmer is available in either a voltage or current model. P/N SD0528810 is designed for voltage units while SD0528811 is for current units. Both units are designed to work with connector option S only. These units are typically used to demonstrate the functionality of the LDT in the field, however, they can be used as a handy troubleshooting / programming device.



1. Attach the 5 pin Euro connector to the VMAX.
2. Push the toggle switch to the ON position to power the LDT.
3. Place magnet assembly where Zero is to be located, but within the active region of the probe.
4. Push the black Zero button for 4 seconds, release for 1 second. Within 5 seconds, push the Zero button again. This completes the Zero programming process.
5. Place magnet assembly where Span is to be located, but within the active region of the probe.
6. Push the black Zero button for 4 seconds, release for 1 second. Within 5 seconds, push the Span button.

**NOTE:** This time the Span button is pushed for the final programming step.

This completes the programming process.

### Optional In-Line Programmer

The 955-1409 is a remote programmer that can help simplify the programming process. The programmer is a portable device that can be temporarily or permanently installed in series with the VMAX with connector option S.



1. Remove the 5 pin cordset to the LDT.
2. Attach the existing cordset to the 955-1409 programmer.

3. Attach the other end to the LDT.
4. Apply power to the LDT.
5. Place magnet assembly where Zero is to be located, but within the active region of the probe.
6. Push the Zero button for 4 seconds. Release the button for 1 second. Within 5 seconds, push the Zero button again.
7. Place magnet assembly where Span is to be located, but within the active region of the probe.
8. Push the Zero button for 4 seconds. Release the Zero button for 1 second. Within 5 seconds, push the Span button.

This completes the programming process.

## Appendix A: Troubleshooting

A Tri-color LED is conveniently located next to the connector to help with set-up and diagnostics.

Diagnostic LED	
LED Color	Description
<b>None</b>	No power to LDT
<b>Green</b>	Magnet signal detected and within programmed range.
<b>Yellow</b>	Magnet signal detected, but magnet is outside of programmed range. <b>NOTE:</b> Magnet can be programmed in this range if desired.
<b>Red</b>	No magnet signal detected. Make sure magnet is on the rod and within the active area. Move magnet back into the range and cycle power.

If a problem exists after reading this section, please contact our technical support department.

### General Checks

Make sure that the magnet is located within the LDT's active stroke area. Keep in mind that the LDT is programmable over the entire active stroke area. Captive magnet assemblies should be positioned so that they can move freely over the entire area of the active stroke without binding or pushing on the rod end. Non-captive magnet assemblies should be situated so that the magnet is no farther than 0.2" from the rod at any point in the magnet assembly's movement.

**NOTE:** Ferromagnetic material (material readily magnetized) should be located no closer than 0.25"

from the magnet or LDT rod end. This includes mounting brackets, magnet spacers, magnet brackets, and mounting screws. Ferromagnetic material can distort the magnetic field, causing adverse operation or even failure of the LDT.

Check all LDT wires for continuity and/or shorts. It is preferred that the cable between the LDT and the interface device be one continuous run. If you are using a junction box, it is highly recommended that the splice junction box be free of AC and/or DC transient-producing lines. The shield should be carried through the splice and terminated at the interface device end.

### Power Supply Checks

This section will help you to determine if your power supply is adequate for the LDT to operate properly, or if the LDT's cable has a short or open.

In order for the VMAX to operate properly, the external power supply must provide a level between 7-30 VDC. A power supply providing voltage above this specified range may damage the LDT. A power supply providing power below this specified range will not be sufficient to power the LDT. When powering more than one VMAX on a single power supply, remember that each unit requires approximately one watt of power. The amount of current draw will vary based on the input voltage used. To calculate the current draw for a particular LDT, divide the LDT wattage by the input voltage. For example, 1 watt divided by 24 VDC equals 41.6mA.





If the LDT is not operating properly, the LDT's cable may have an open or short, or the power supply is not supplying sufficient power. To verify this:

1. Turn the power supply off.
2. Remove the mating connector from the LDT.
3. Turn the power supply on.
4. Using a digital voltmeter, check across Power Supply Common and customer supplied power (+VDC) on the mating end of the cable for a level between 7 and 30 VDC.

**NOTE:** LDT's with integral cable assemblies should be checked for proper voltage at the power supply terminals. This cable assembly cannot be removed from the LDT.

If the reading is between 7 and 30 VDC, turn power supply off and go to step 7. If the reading is below 7 VDC, either the power supply is not providing enough power or the LDT's cable possibly has a short or open. A reading of no voltage or minimal voltage (less than 5 volts) may be due to a short or open in the cable. If the reading is not between 7 and 30 VDC, go to step 5. If the reading is above 30 VDC, adjust power supply or replace.

5. Turn the power supply off.
6. Check the continuity of the individual wires of the cable between the power supply and the LDT. Check for continuity from one end of the cable to the other. Also, verify that no shorts exist between pins.
7. Reconnect the mating connector to the LDT.

## Appendix B: Part Numbering

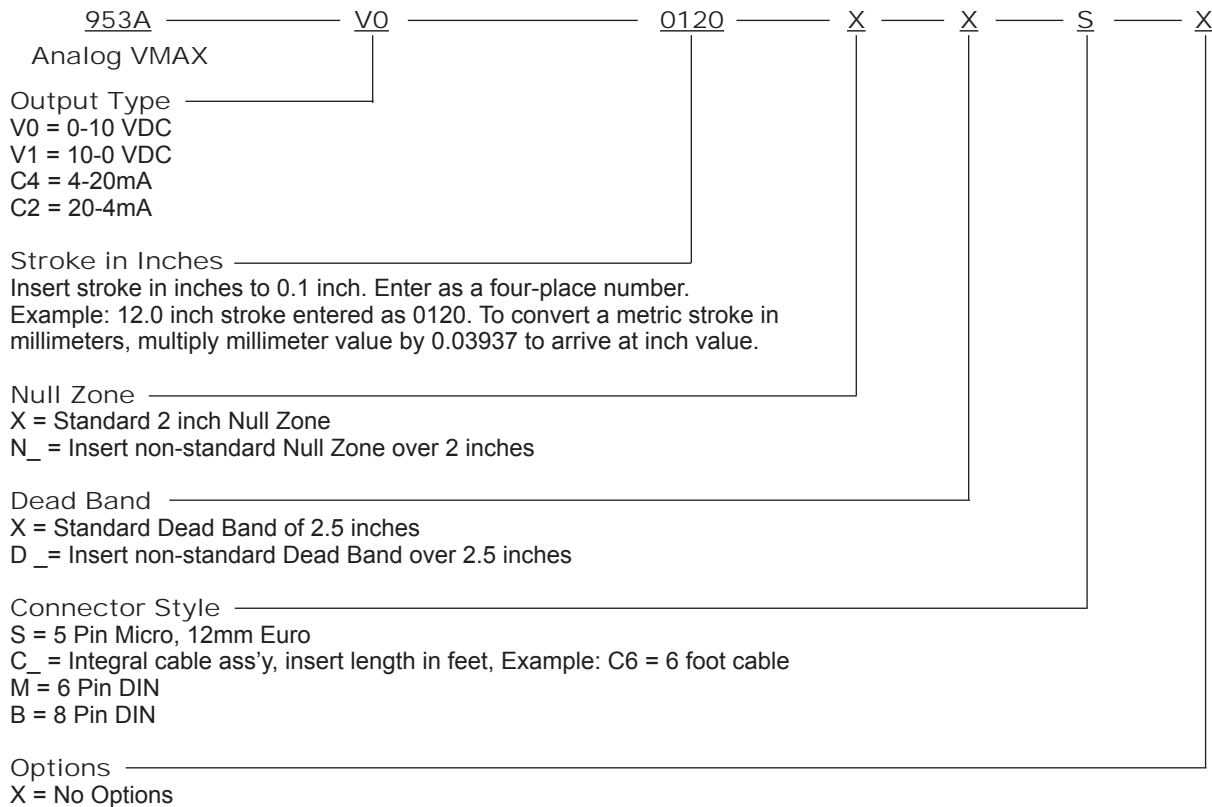

NOTE 1: On unsupported stroke lengths greater than 4 feet, rod support bracket(s) and a special magnet should be used.

NOTE 2: Specify magnet as separate line item. Standard magnet is SD0400800.





Other Products



Copyright 2007 by AMETEK Automation & Process Technologies. All Rights Reserved. Made in the USA.



1080 N. Crooks Road, Clawson, MI 48017-1097  
Phone: 248.435.0700 Toll Free: 800.635.0289  
Fax: 248.435.8120 [www.ametekapt.com](http://www.ametekapt.com)

953A.M1R  
1/07.Z191

