

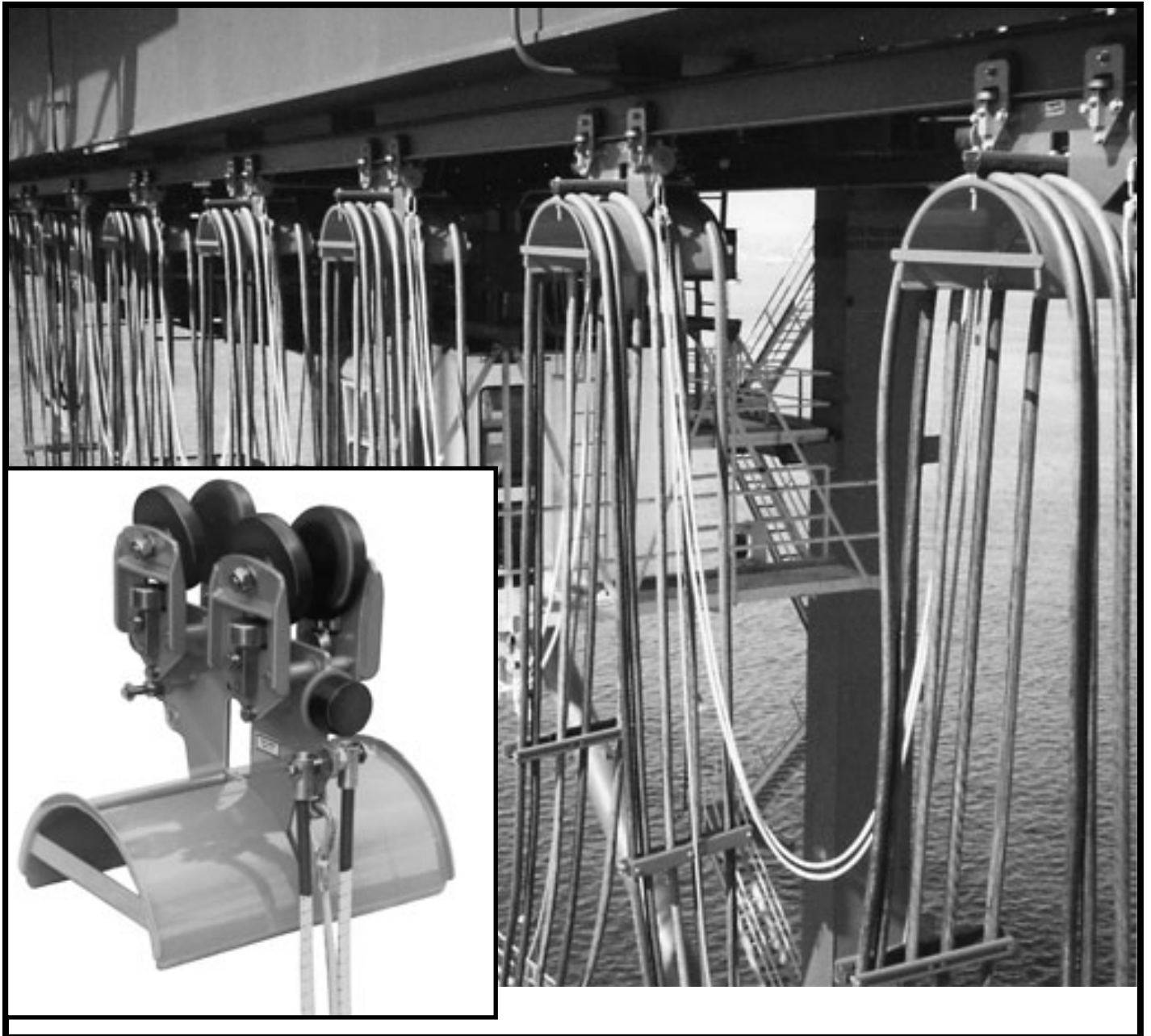

# Beam·Master™

**FESTOON SYSTEMS**



## ***Container Crane Series I-152 and I-162***

Spec Tech Industrial 203 Vest Ave. Valley Park, MO 63088 Phone: 888 SPECTECH  
E-mail: [sales@spectechind.com](mailto:sales@spectechind.com) [www.spectechind.com](http://www.spectechind.com)

# Container Crane Series I-152 and I-162

- All the **FEATURES** required for years of high speed service, even under the most rugged conditions.
- All the **OPTIONS** needed to precisely fit your specific application.
- Built and backed by the leader in cable and hose management systems.

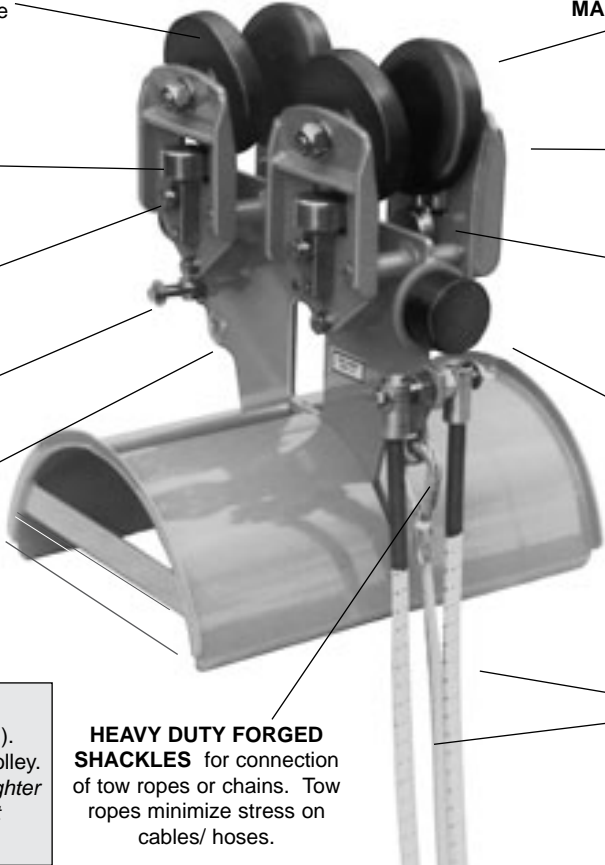

**WEAR GROOVES** allow quick visual inspection of main wheels to determine if replacement is necessary

**EXTRA WIDE SIDE GUIDE ROLLERS**  
Hardened steel. Maintain trolley alignment. Beam contact is retained even when main trolley wheels wear.

Optional **STAINLESS STEEL** threaded fasteners and axles provide outstanding corrosion resistance

**HEAVY-DUTY MOUNTING PINS**  
Anchor shock cords to trolley. Allow shock cords to pivot freely.

**WELDED STEEL TROLLEY BODY AND SADDLE**  
Extra strength. Continuous welds and rounded edges protect cables from undue wear and abrasion.

**CROWNED or FLANGED MAIN TROLLEY WHEELS.**  
Available in steel or nylon.

**INDIVIDUAL SIDE PLATE ASSEMBLIES.**  
Allow wheel to be removed for maintenance without removing trolley from system.

**HARDENED STEEL ANTI-LIFT ROLLERS.**  
Keep trolley stable, even in high winds.

**HEAVY DUTY BUMPERS,** each end of trolley. Absorb forces when trolleys impact during normal operation. Adjustable bumpers also available for retrofit projects to align Gleason bumpers with existing bumpers.

**SHOCK CORDS** 5/8" dia. Get trolleys moving more smoothly during rapid acceleration. Provide festoon system that operates smoothly with minimum stress on tow ropes and cables/ hoses.

**HEAVY DUTY FORGED SHACKLES** for connection of tow ropes or chains. Tow ropes minimize stress on cables/ hoses.

**HIGH SPEED/CAPACITY**  
Maximum speeds over 800 fpm (240 m/m).  
Maximum capacity to 1100 lbs.(495 kg) per trolley.  
*NOTE: Maximum speed possible only with lighter loads. Maximum capacity possible only at slower speeds. Please consult factory.*

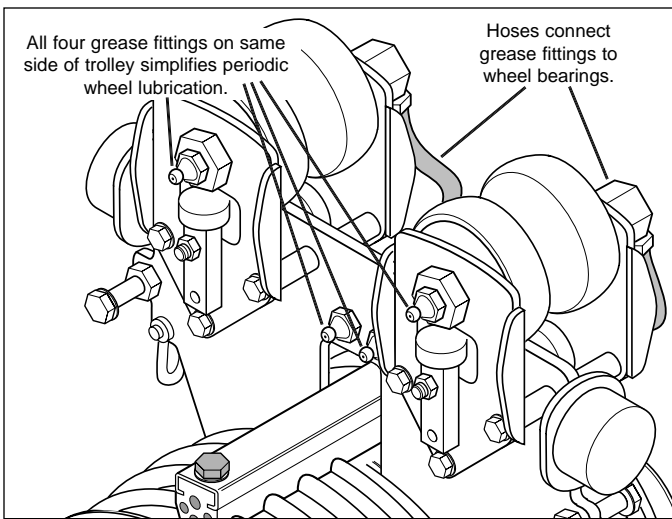

**OPTIONAL GREASABLE WHEELS CAN BE LUBRICATED FROM ONE SIDE OF TROLLEY.** No need to move personnel support to reach all four wheels. Speeds periodic lubrication.

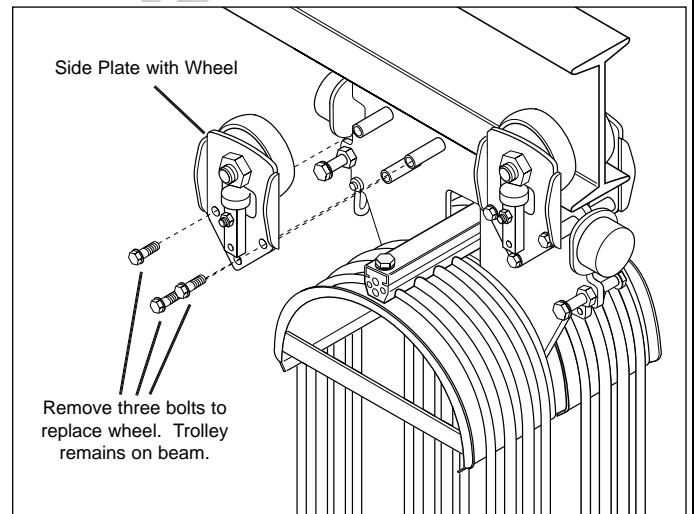

**REPLACE WHEELS WITH TROLLEY ON BEAM.** Side plates holding wheels can be easily removed, one at a time, to repair or replace wheels or rollers. Trolley stays on beam.

# Loaded with Options...easily customized to your application

## Choice of Cable Clips or Clamps

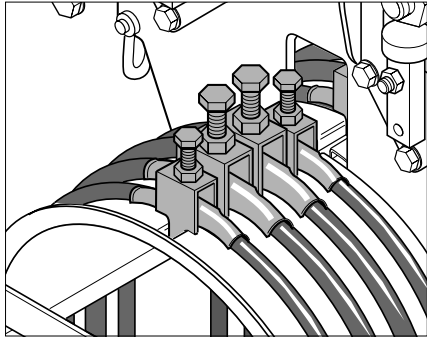

**OPTION ONE: INDIVIDUAL CLIPS FOR EACH CABLE/ HOSE**

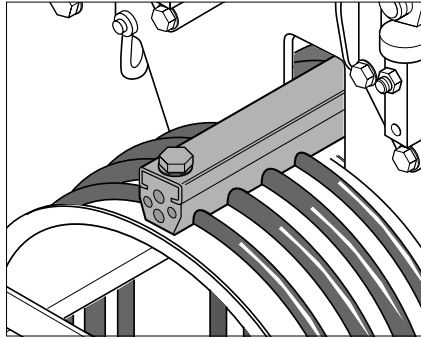

**OPTION TWO: SINGLE CLAMP**  
11.5" & 15" wide carriages only

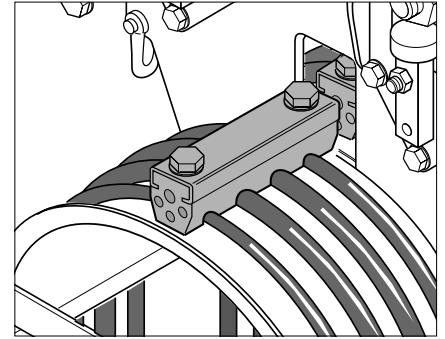

**OPTION THREE: DUAL CLAMPS**  
20"-30" wide carriages only

## Choice of Wheels

**DIAMETER\***: 3.94" or 6.0" • **MATERIAL**: Steel or Nylon • **TYPE**: Crowned or Flanged • **LUBRICATION**: Prelubricated or greasable

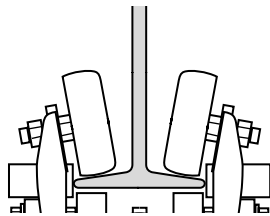

**CROWNED WHEEL**  
steel or nylon

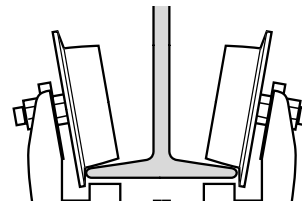
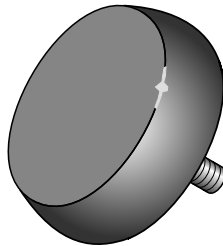

**FLANGED WHEEL**  
steel or nylon

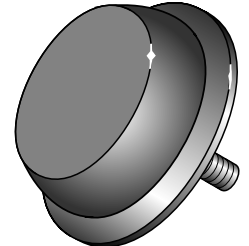

\*I-152 series has 3.94" dia. wheels. I-162 series has 6.00" dia. wheels.

## Choice of Finish and Hardware

- Painted trolley with Zinc Plated hardware
  - Painted trolley with Stainless hardware
  - Galvanized trolley with Stainless hardware
- Standard finish is Gleason orange baked polyester. Double coat, marine duty finish and custom colors also available.

## Choice of Field Assembly or Factory Pre-assembly

Cable may be installed on trolleys at job sight, or Gleason will install cables to your specifications and ship on specially designed frames, ready for transferring to your I-beam. See page 6.

## Cable Clamps, Additional Saddles, Catenary System, and other options

Single, dual and bar loop clamps are available. See page 8. Use one or two per loop to stabilize cable in system.

Additional saddles may be added or wider saddles used to accommodate large number of cables (page 7).

Special design trolleys are available for attaching to the crane catenary trolley for maximum system efficiency.

Contact factory for details on these and other options.

## HOW TO ORDER

Options in model numbers on following pages are shown in **BOLD FACE** below. Substitute letters shown for other desired options.

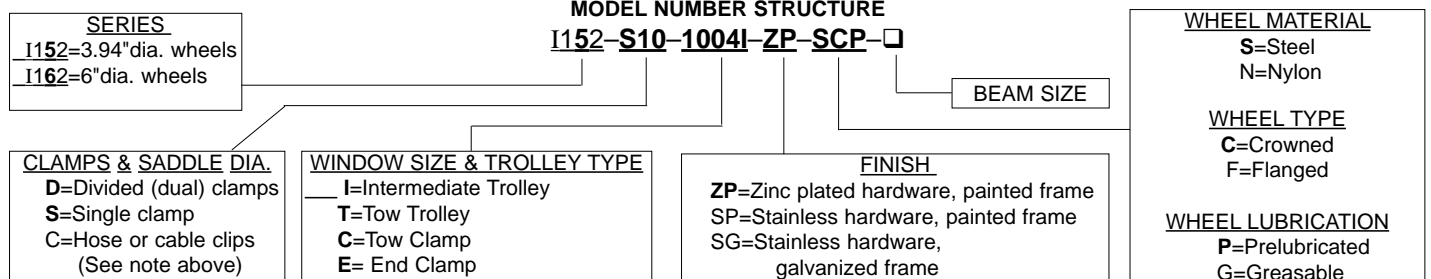

# INTERMEDIATE TROLLEYS

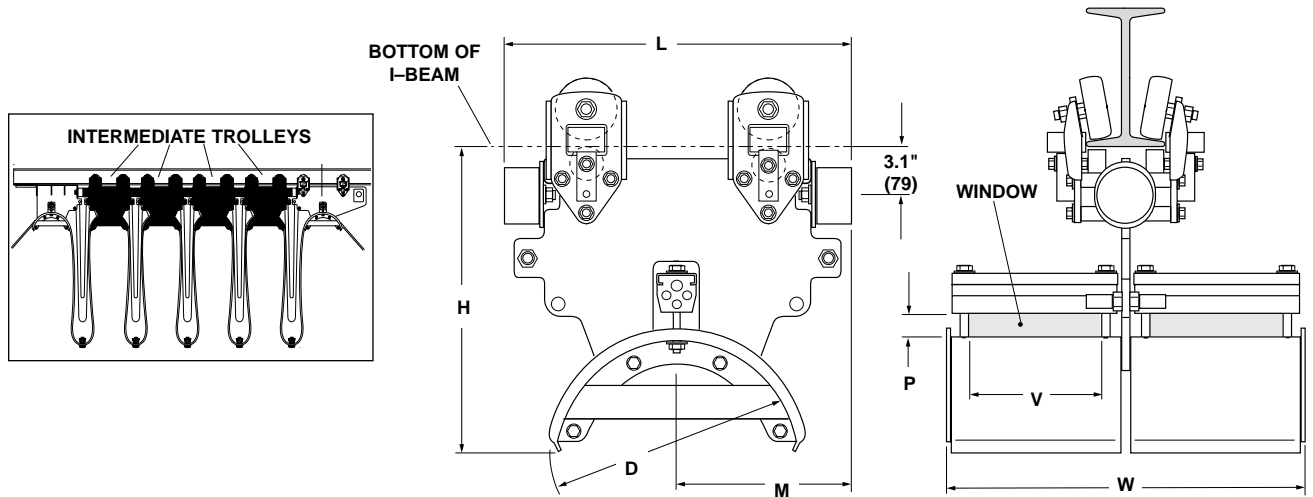

MODELS AND DIMENSIONS—in.(mm)

SERIES I-152 3.94" dia. WHEELS	SERIES I-162 6" dia. WHEELS	"D" SADDLE DIA.	"P" WINDOW HEIGHT*	"V" WINDOW WIDTH*	"H" BELOW I-BEAM	"L" OVERALL LENGTH	"W" OVERALL WIDTH	"M" SADDLE LOCATOR
I152-S10-1004I-ZP-SCP-□	I162-S10-1004I-ZP-SCP-□	10.25 (260)	1.06 (27)	4.38(111)	15.10 (384)	15.36 (390)	11.51(292) 15.13(384) 20.51(521) 25.06(637) 30.20(767)	7.68 (195)
I152-S10-1006I-ZP-SCP-□	I162-S10-1006I-ZP-SCP-□			6.19(157)				
I152-D10-1007I-ZP-SCP-□	I162-D10-1007I-ZP-SCP-□			7.88(200)				
I152-D10-1010I-ZP-SCP-□	I162-D10-1010I-ZP-SCP-□			10.17(258)				
I152-D10-1012I-ZP-SCP-□	I162-D10-1012I-ZP-SCP-□			12.69(326)				
I152-S10-3304I-ZP-SCP-□	I162-S10-3304I-ZP-SCP-□	14.12 (359)	3.30 (84)	4.38(111)	16.60 (422)	18.62 (473)	11.51(292) 15.13(384) 20.51(521) 25.06(637) 30.20(767)	9.31 (236)
I152-S10-3306I-ZP-SCP-□	I162-S10-3306I-ZP-SCP-□			6.19(157)				
I152-D10-3307I-ZP-SCP-□	I162-D10-3307I-ZP-SCP-□			7.88(200)				
I152-D10-3310I-ZP-SCP-□	I162-D10-3310I-ZP-SCP-□			10.17(258)				
I152-D10-3312I-ZP-SCP-□	I162-D10-3312I-ZP-SCP-□			12.69(326)				
I152-S14-1404I-ZP-SCP-□	I162-S14-1404I-ZP-SCP-□	18.12 (460)	1.44 (37)	4.38(111)	18.10 (460)	22.94 (587)	11.51(292) 15.13(384) 20.51(521) 25.06(637) 30.20(767)	11.47 (291)
I152-S14-1406I-ZP-SCP-□	I162-S14-1406I-ZP-SCP-□			6.19(157)				
I152-D14-1407I-ZP-SCP-□	I162-D14-1407I-ZP-SCP-□			7.88(200)				
I152-D14-1410I-ZP-SCP-□	I162-D14-1410I-ZP-SCP-□			10.17(258)				
I152-D14-1412I-ZP-SCP-□	I162-D14-1412I-ZP-SCP-□			12.69(326)				
I152-S18-1804I-ZP-SCP-□	I162-S18-1804I-ZP-SCP-□	18.12 (460)	1.81 (46)	4.38(111)	18.10 (460)	22.94 (587)	11.51(292) 15.13(384) 20.51(521) 25.06(637) 30.20(767)	11.47 (291)
I152-S18-1806I-ZP-SCP-□	I162-S18-1806I-ZP-SCP-□			6.19(157)				
I152-D18-1807I-ZP-SCP-□	I162-D18-1807I-ZP-SCP-□			7.88(200)				
I152-D18-1810I-ZP-SCP-□	I162-D18-1810I-ZP-SCP-□			10.17(258)				
I152-D18-1812I-ZP-SCP-□	I162-D18-1812I-ZP-SCP-□			12.69(326)				

□=Include Beam Size to Complete Model Number

\*Window height and width do not apply to clip (-Cxx-) models. Clips available on all saddle widths. Consult factory for quantity and size of clips required for your application. To order clips, replace S or D in model numbers above with C. See page 5 for details.

## I-152/162 TROLLEYS DESIGNED FOR MAXIMUM LIFE, MINIMUM MAINTENANCE

Especially designed for container cranes and other high speed, high use applications where long runs and high cable loadings are the norm. Multiple options, such as special finishes and wide range of beam sizes, allow you to build a customized system that will provide maximum service life.



# TOW TROLLEY

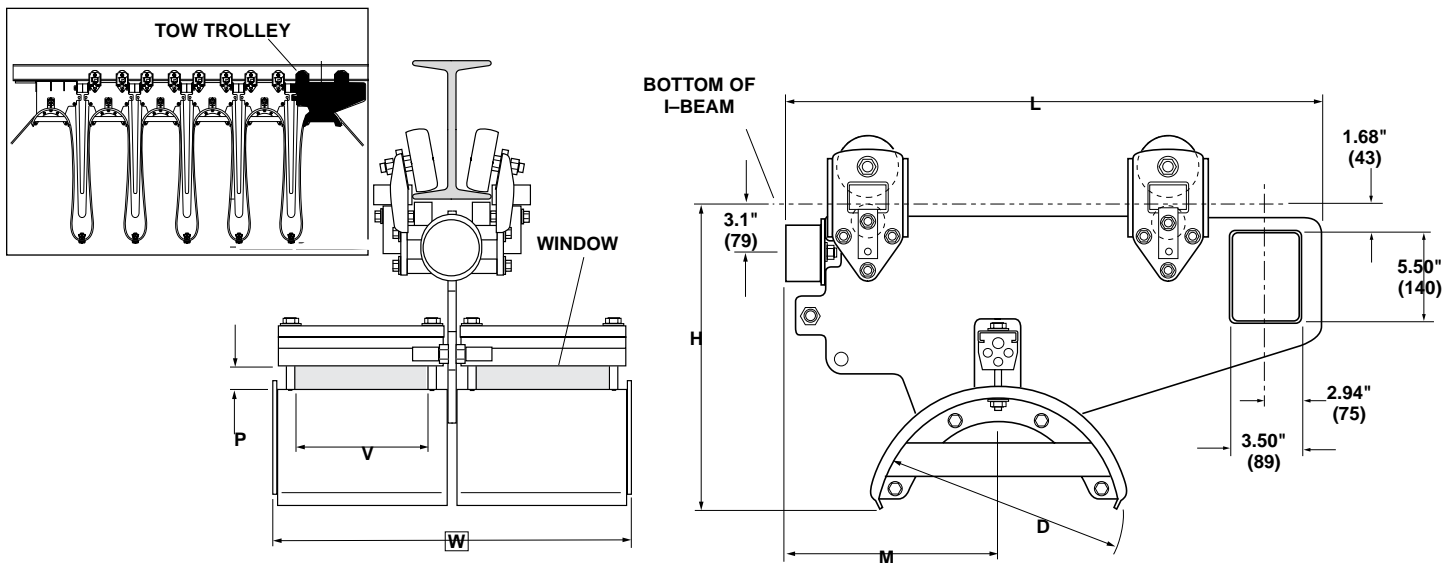

MODELS AND DIMENSIONS—in.(mm)

SERIES I-152 3.94" dia. WHEELS	SERIES I-162 6" dia. WHEELS	"D" SADDLE DIA.	"P" WINDOW HEIGHT*	"V" WINDOW WIDTH*	"H" BELOW I-BEAM	"L" OVERALL LENGTH	"W" OVERALL WIDTH	"M" SADDLE LOCATOR
I152-S10-1004T-ZP-SCP-□	I162-S10-1004T-ZP-SCP-□	10.25 (260)	1.06 (27)	4.38(111)	15.10 (384)	18.66 (474)	11.51(292)	7.76 (197)
I152-S10-1006T-ZP-SCP-□	I162-S10-1006T-ZP-SCP-□			6.19(157)				
I152-D10-1007T-ZP-SCP-□	I162-D10-1007T-ZP-SCP-□			7.88(200)				
I152-D10-1010T-ZP-SCP-□	I162-D10-1010T-ZP-SCP-□		10.17(258)					
I152-D10-1012T-ZP-SCP-□	I162-D10-1012T-ZP-SCP-□		12.69(326)					
I152-S10-3304T-ZP-SCP-□	I162-S10-3304T-ZP-SCP-□		3.30 (84)	4.38(111)				
I152-S10-3306T-ZP-SCP-□	I162-S10-3306T-ZP-SCP-□	6.19(157)						
I152-D10-3307T-ZP-SCP-□	I162-D10-3307T-ZP-SCP-□	7.88(200)						
I152-D10-3310T-ZP-SCP-□	I162-D10-3310T-ZP-SCP-□	14.12 (359)	1.44 (37)	10.17(258)	16.60 (422)	25.31 (643)	25.06(637)	11.00 (279)
I152-D10-3312T-ZP-SCP-□	I162-D10-3312T-ZP-SCP-□			12.69(326)				
I152-S14-1404T-ZP-SCP-□	I162-S14-1404T-ZP-SCP-□			4.38(111)				
I152-S14-1406T-ZP-SCP-□	I162-S14-1406T-ZP-SCP-□			6.19(157)				
I152-D14-1407T-ZP-SCP-□	I162-D14-1407T-ZP-SCP-□			7.88(200)				
I152-D14-1410T-ZP-SCP-□	I162-D14-1410T-ZP-SCP-□			10.17(258)				
I152-D14-1412T-ZP-SCP-□	I162-D14-1412T-ZP-SCP-□	12.69(326)						
I152-S18-1804T-ZP-SCP-□	I162-S18-1804T-ZP-SCP-□	18.12 (460)	1.81 (46)	4.38(111)	18.10 (460)	30.82 (783)	11.51(292)	13.75 (349)
I152-S18-1806T-ZP-SCP-□	I162-S18-1806T-ZP-SCP-□			6.19(157)				
I152-D18-1807T-ZP-SCP-□	I162-D18-1807T-ZP-SCP-□			7.88(200)				
I152-D18-1810T-ZP-SCP-□	I162-D18-1810T-ZP-SCP-□			10.17(258)				
I152-D18-1812T-ZP-SCP-□	I162-D18-1812T-ZP-SCP-□			12.69(326)				

□=Include Beam Size to Complete Model Number

\*Window height and width do not apply to clip (-Cxx-) models. Clips available on all saddle widths. Consult factory for quantity and size of clips required for your application. To order clips, replace S or D in model numbers above with C. See below for details.

## STAINLESS STEEL • STAINLESS STEEL FOR LONG LIFE CABLE CLIPS • GREATER HOLDING POWER • EASIER CABLE REPLACEMENT

Use of Cable Clips is recommended whenever there is high speed travel or when cables vary a great deal in size. Clips hook securely into saddle groove and may be easily moved to adjust cable spacing. To order clips, replace S or D in model numbers with C.

MODEL NUMBER	CABLE DIAMETER in.	mm	WIDTH "A" in.	mm
CLP-01	0.50-0.75	(13-19)	0.97	(25)
CLP-02	0.75-1.00	(19-25)	1.28	(33)
CLP-03	1.00-1.25	(25-32)	1.47	(37)
CLP-04	1.25-1.50	(32-38)	1.72	(44)
CLP-05	1.50-1.75	(38-44)	1.97	(50)
CLP-06	1.75-2.12	(44-54)	2.35	(60)

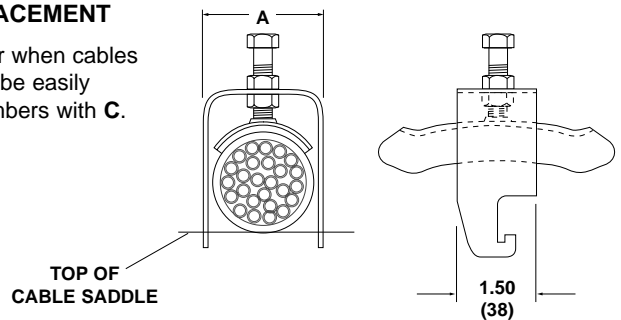

# TOW CLAMP–Optional. Replaces Tow Trolley

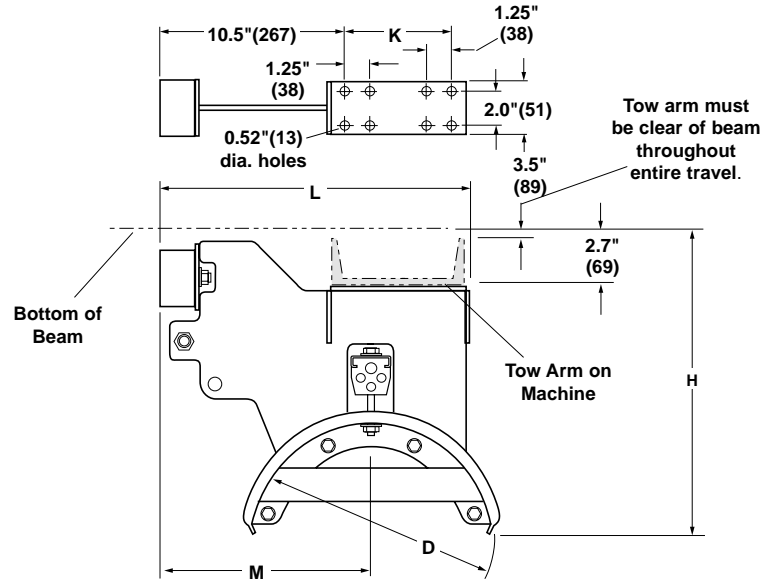
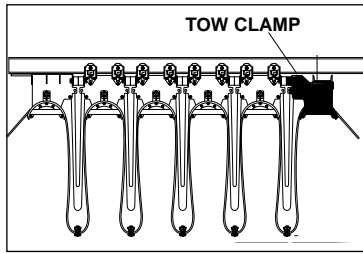

## MODELS AND DIMENSIONS–in.(mm)

SERIES I-152	SERIES I-162	“D” SADDLE DIA.	“P” WINDOW HEIGHT*	“V” WINDOW WIDTH*	“H” BELOW I-BEAM	“L” OVERALL LENGTH	“W” OVERALL WIDTH	“M” SADDLE LOCATOR	“K” BOLT SPACING		
I152-S10-1004C-ZP I152-S10-1006C-ZP I152-D10-1007C-ZP I152-D10-1010C-ZP I152-D10-1012C-ZP	I162-S10-1004C-ZP I162-S10-1006C-ZP I162-D10-1007C-ZP I162-D10-1010C-ZP I162-D10-1012C-ZP	10.25 (260)	1.06 (27)	4.38(111)	15.10 (384)	15.50 (394)	11.51(292) 15.13(384) 20.51(521) 25.06(637) 30.20(767)	12.03 (306)	5.00 (127)		
I152-S10-3304C-ZP I152-S10-3306C-ZP I152-D10-3307C-ZP I152-D10-3310C-ZP I152-D10-3312C-ZP	I162-S10-3304C-ZP I162-S10-3306C-ZP I162-D10-3307C-ZP I162-D10-3310C-ZP I162-D10-3312C-ZP			6.19(157)							
I152-S14-1404C-ZP I152-S14-1406C-ZP I152-D14-1407C-ZP I152-D14-1410C-ZP I152-D14-1412C-ZP	I162-S14-1404C-ZP I162-S14-1406C-ZP I162-D14-1407C-ZP I162-D14-1410C-ZP I162-D14-1412C-ZP			7.88(200)							
I152-S18-1804C-ZP I152-S18-1806C-ZP I152-D18-1807C-ZP I152-D18-1810C-ZP I152-D18-1812C-ZP	I162-S18-1804C-ZP I162-S18-1806C-ZP I162-D18-1807C-ZP I162-D18-1810C-ZP I162-D18-1812C-ZP		10.17(258)	16.60 (422)						19.00 (483)	25.06(637) 30.20(767)
			12.69(326)								
				3.30 (84)						4.38(111)	
			1.44 (37)	6.19(157)							
			1.81 (46)	7.88(200)							
				10.17(258)							
				12.69(326)							

\*Window height and width do not apply to clip (-Cxx-) models. Clips available on all saddle widths. Consult factory for quantity and size of clips required for your application. To order clips, replace S or D in model numbers above with C. See page 5 for details.

## FACTORY PRE-ASSEMBLY

- SPEEDS FIELD INSTALLATION
- REDUCES “DOWN TIME” FOR REPLACEMENT FESTOONS

Trolleys can be shipped with cable pre-hung, ready for transfer to your crane. Specially built frames are lifted into position and festoon rolls onto beam. Affix end and tow clamps, make electrical connections, and your crane is in business.



# END CLAMP

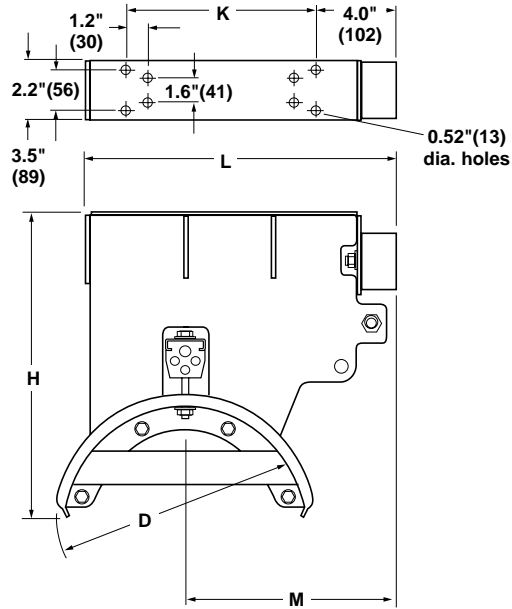
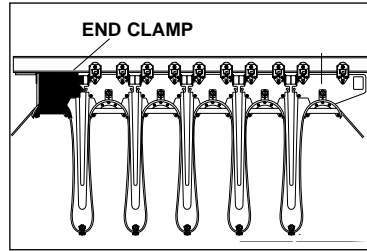

MODELS AND DIMENSIONS—*in. (mm)*

SERIES I-152	SERIES I-162	“D” SADDLE DIA.	“P” WINDOW HEIGHT*	“V” WINDOW WIDTH*	“H” BELOW I-BEAM	“L” OVERALL LENGTH	“W” OVERALL WIDTH	“M” SADDLE LOCATOR	“K” BOLT SPACING
I152-S10-1004E-ZP I152-S10-1006E-ZP I152-D10-1007E-ZP I152-D10-1010E-ZP I152-D10-1012E-ZP	I162-S10-1004E-ZP I162-S10-1006E-ZP I162-D10-1007E-ZP I162-D10-1010E-ZP I162-D10-1012E-ZP	10.25 (260)	1.06 (27)	4.38(111)	15.10 (384)	12.32 (313)	11.51(292)	8.52 (216)	7.07 (180)
I152-S10-3304E-ZP I152-S10-3306E-ZP I152-D10-3307E-ZP I152-D10-3310E-ZP I152-D10-3312E-ZP	I162-S10-3304E-ZP I162-S10-3306E-ZP I162-D10-3307E-ZP I162-D10-3310E-ZP I162-D10-3312E-ZP			6.19(157)			15.13(384)		
I152-S14-1404E-ZP I152-S14-1406E-ZP I152-D14-1407E-ZP I152-D14-1410E-ZP I152-D14-1412E-ZP	I162-S14-1404E-ZP I162-S14-1406E-ZP I162-D14-1407E-ZP I162-D14-1410E-ZP I162-D14-1412E-ZP			7.88(200)			20.51(521)		
I152-S18-1804E-ZP I152-S18-1806E-ZP I152-D18-1807E-ZP I152-D18-1810E-ZP I152-D18-1812E-ZP	I162-S18-1804E-ZP I162-S18-1806E-ZP I162-D18-1807E-ZP I162-D18-1810E-ZP I162-D18-1812E-ZP			10.17(258)			25.06(637)		
				12.69(326)			30.20(767)		
		14.12 (359)	3.30 (84)	4.38(111)	16.60 (422)	15.50 (394)	11.51(292)	10.51 (267)	10.25 (260)
		18.12 (460)	1.44 (37)	6.19(157)	18.10 (460)	19.00 (483)	15.13(384)	12.65 (321)	13.76 (350)
			1.81 (46)	7.88(200)			20.51(521)		
				10.17(258)			25.06(637)		
				12.69(326)			30.20(767)		

\*Window height and width do not apply to clip (-Cxx-) models. Clips available on all saddle widths. Consult factory for quantity and size of clips required for your application. To order clips, replace S or D in model numbers above with C. See page 5 for details.

## STACKED SADDLES

- ALLOW YOU TO ADD MORE CABLES TO YOUR SYSTEM  
(Up to rated weight capacity of the trolleys)

Stacking cable saddles is often the most desirable way to efficiently handle a large number of cables on the same festoon system. Especially desirable if obstructions preclude greater saddle width. Consult factory for full details.



# Accessories

## Single Loop Clamps

Clamping pads are neoprene. Standard hardware is zinc plated steel. Finish is orange polyester powder.

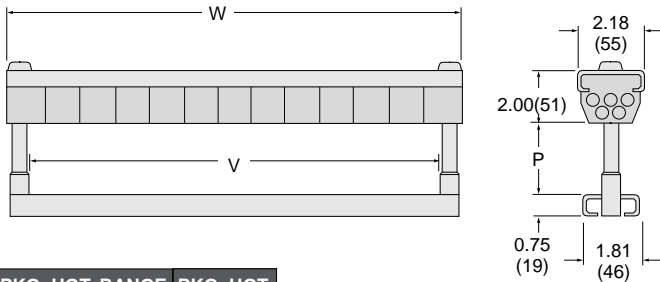

PKG. HGT. RANGE "P"	PKG. HGT. CODE □
0.45-0.95 (11-24)	1
0.65-1.15 (17-29)	2
1.04-1.54 (26-39)	3
1.44-1.94 (37-49)	4
1.83-2.33 (46-59)	5
2.22-2.72 (56-69)	6
2.70-3.51 (69-89)	7

MODEL NUMBER	WINDOW "V"	WIDTH "W"
CLH-S09-□-Z	9.18 (233)	11.06 (281)
CLH-S12-□-Z	12.81 (325)	14.68 (373)

May be supplied with stainless steel hardware. Substitute "S" for "Z" in model numbers above.

Package Height (o.d. of largest cable) Code is substituted for □ to complete model number. Table also applies to Double Clamps, below.

## Dual Loop Clamps

Clamping pads are neoprene. Standard hardware is zinc plated steel. Finish is orange polyester powder.

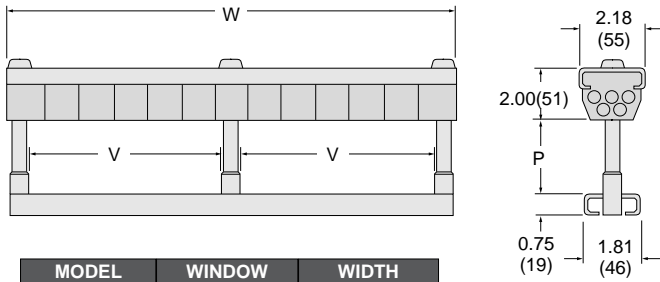

MODEL NUMBER	WINDOW "V"	WIDTH "W"
CLH-D07-□-Z	8.78 (223)	20.06 (510)
CLH-D10-□-Z	11.06 (277)	24.62 (625)
CLH-D12-□-Z	13.83 (351)	30.17 (766)

See PACKAGE HEIGHT CODE table above for "P".

Stainless steel hardware optional. Substitute "S" for "Z" in model numbers above.

## Heavy Duty Tow Ropes

Vinyl coated .38/.44" wire rope.  
-Heavy duty steel shackles included.

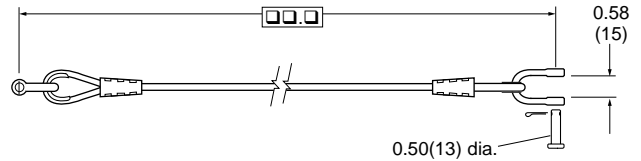

MODEL NUMBER	ROPE MATERIAL
TRH-□□.□-Z	Galvanized steel
TRH-□□.□-S	Stainless steel

Substitute required length in feet for "□□.□" to complete Model Number. Round up to nearest half foot.

## Heavy Duty Shock Cords

Designed specifically to survive the rigors of high speed container crane applications. Industrial grade 5/8" elastomeric cords with stainless steel ends fasten to posts on trolleys.

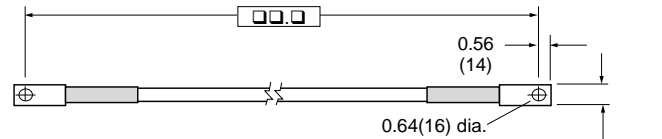

MODEL NUMBER
SCH-□□.□

Substitute required length in feet for "□□.□" to complete Model Number. Round up to nearest half foot.

1.12 dia. (28)

## Bar Cable Loop Clamps

One half inch thick aluminum bars, custom milled to your requirements. Rounded edges reduce cable wear. Stainless steel fasteners. Consult factory for more information.

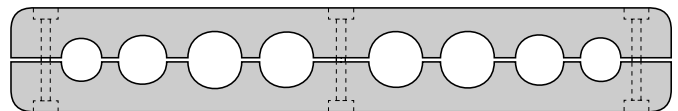

We reserve the right to ship the most current designs.



## Gleason Reel Corp.

P.O. Box 26 • 600 S. Clark St.  
Mayville, Wisconsin 53050-0026  
Phone 920/387-4120 • FAX 920/387-4189

In your area contact: