

Installation and Programming Manual



PLC Interface Module for Resolver/LDT Interfacing



1080 North Crooks Road
Clawson, MI 48017-1097
Phone: (248) 435-0700
FAX: (248) 435-8120
Internet: www.ametekapt.com
www.ametek.com

Preface

This manual is divided into four parts. Part 1 provides an introduction for the Theory and Operation of the Series 2120 PLC Interface Module. Part 2 contains a Hardware Overview. Part 3 explains the Mounting and Wiring of the 2120 PLC Interface Module. Part 4 provides the Programming Instructions. Also included are four Appendixes; Error Messages, Function Summary Chart, Catalog Numbering System, and Specifications. A glossary and index are also provided at the back of this manual.



Disconnect power before servicing. The Gemco Series 2120 contains no servicable components other than the power supply fuse. Consult factory for repair or replacement.

Copyright 1997, 1998, 1999, 2001 by AMETEK
All Rights Reserved - Made in the U.S.A.
Version 0.3

AMETEK has checked the accuracy of this manual at the time it was printed. Any comments you may have for the improvement of this manual are welcomed.

AMETEK reserves the right to revise and redistribute the entire contents or selected pages of this manual. All rights to the contents of this manual are reserved by AMETEK.

Contents

Chapter 1: Theory of Operation	1
Chapter 2: Hardware Overview	2
2.1 Standard Modules	3
Controller (FMMP01)	3
Power Supply (FMPS01)	3
2.2 Input/Output Module	3
Resolver (FMIR01)	3
Variable Pulse (FMIP01)	4
LDT Input (FMIP020)	4
Digital Output (FMOD01)	4
Analog Output (FMOA01)	4
Relay Output (FMOR01)	5
2.3 Status LEDs Defined	5
Chapter 3: Mounting and Wiring	7
Things to Consider	7
3.1 Mounting	7
Interface Module	7
Cabling	8
3.2 Wiring	10
Controller Module (FMMP01)	10
Relay Output Module (FMOR01)	10
Power Supply Module (FMPS01)	11
Resolver Module (FMIR01)	12
Variable Pulse LDT Module (FMIP01)	12
LDT Input (FMIP02)	13
Digital Output (FMOD01)	13
Analog Output (FMOA01)	14
Chapter 4: Programming	21
Before You Start	21
Programming Keys Defined	22
4.1 Resolver Input Configuration Functions	23
Scale Factor (300)	23
Turns Counting (301)	23
Turns Counting Wrap Around (308)	24
Position Offset (302)	24
Programming Scale Factor (300)	24
Display Power-Up (305)	26
Resolver Reset-to-Preset (307)	26

4.2 : LDT Configuration Functions.....	27
Wire Speed (300)	28
Count Direction (301)	28
Position Offset (302)	29
Fault Pulse Time (306)	30
LDT Output Type (307)	30
LDT L1 Input Reset-to-Preset (311)	31
4.3 : Monitor Setup Functions	31
Unit of Measurement (14).....	31
Decimal Location (13)	32
Position Hold (15).....	32
Auxiliary LED (16).....	33
Move Detection Time-Out(12).....	34
4.4: Relay Setup Functions	34
Upper End Limit (400).....	35
Lower End Limit (401)	35
Relay State (402).....	36
Relay Override (403).....	36
4.5: Digital Outputs.....	37
Output Type (200)	37
Latch/Synchronize Handshake (201)	37
Logic Level (202).....	38
Error Condition Output State (203)	38
4.6: Analog Outputs	39
Analog Output Channel 1	39
Analog Output Channel 2	42
4.7: Program and Supervisory Mode Functions	43
Program Mode Access (10).....	43
Program Mode Time-out (11)	44
 Appendix A: Error Messages	 45
Error Conditions (306).....	50
 Appendix B: Function Summary Chart	 51
 Appendix C: Catalog Numbering System	 53
 Appendix D: Specifications	 54
 Glossary	 56
Index.....	58

Chapter 1: Theory of Operation

The Gemco Series 2120 PLC Interface Module converts the input signal from a resolver based rotary transducer or Magnetostrictive Linear Displacement Transducer (LDT) to digital analog or overtravel relay outputs. Resolver based inputs provide up to 14 bit resolution per turn with a field programmable scale factor. LDT based inputs allow field selection of position data in inches to .001 inches or millimeters to .01 millimeter. The module's 6 digit display can show position or velocity data. The optional 20 bit digital output board allows field configuration of parallel digital outputs in a binary, BCD or grey code format. The optional analog output board allows field selection of a voltage or current output of position or velocity and is scalable over any portion of the displayed data. The optional relay output board provides two mechanical relay outputs intended for use as overtravel limits.

Advanced features include:

- Reset-to-Preset input for continuous recalibration or compensation for process drift.
- Turns counting software for multiple turn applications using a single turn resolver.
- Move detection software for detection of a jammed motor driven mechanism or drive component failure.
- Position hold input to freeze displayed data during high vibration periods at the sensor.

Field programmed data is protected by a hard contact closure on the back of the module and a user selectable security code.

Chapter 2: Hardware Overview

This chapter contains descriptions of the Interface Module's components. For installation instructions, see Chapter 3: Mounting and Wiring.

The Interface Module contains a heavy-duty case which can hold up to five modules. Several optional modules can be used with the Interface Module. See also Appendix C: Catalog Numbering System for more information on optional modules.

- Power Supply
- Controller (CPU)
- Digital Output (optional)
- Analog Output (optional)
- Resolver Input (optional)
- Linear Displacement Transducer L1 (optional)
- Linear Displacement Transducer V1 (optional)
- Relay Output (optional)

The Interface Module's faceplate contains a 6-digit, seven-segment LED display and four programming keys. The LED display is used to indicate the position, as well as to display parameters when programming. The programming keys are used to program the Interface Module. Ten small status LEDs are also provided. These LEDs are used to indicate the state of the monitor during machine operation.

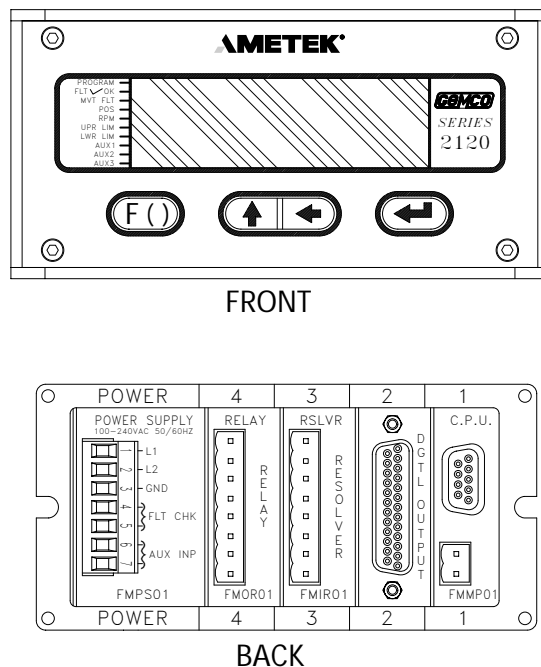

Figure 2-1 Interface Module with Resolver/Digital Modules

2.1: Standard Modules

This section provides descriptions of basic Interface Modules (also see Section 2.2: Input/Output Modules).

Controller (FMMP01)

This module contains the Central Processing Unit (CPU) which is used to process data it receives from the resolver or Linear Displacement Transducer (LDT). It then shows the position on the Interface display. The controller is also responsible for continuously monitoring all programmed setpoints and timing functions. To store programmed functions, including fixed settings, the controller contains battery-backed memory. This battery requires no maintenance and is non-replaceable. To allow for remote communications with the Interface Module, RS-232 and RS-485 serial ports are available through a D9 connector. The controller is located in slot 1 of the enclosure. (For wiring instructions, see Section 3.2: Wiring)

Power Supply (FMPS01)

This module supplies power to the Interface Module. It also contains a fault check relay and an auxiliary input. The fault check relay is designed to take power away from the operating machine when a fault occurs during machine operation, or when power is taken away from the Interface Module. In order for this to perform its intended function, the fault check relay must be properly wired to the machine's safety interlock. For a listing of errors which will cause the fault check relay to deenergize, see Chart A-4 in Appendix A: Error Messages. The auxiliary input is designed for the Move Detection Time-out and Position Hold functions and accepts an 85-265 VAC input signal. The power supply is located in slot 5 of the enclosure. (For wiring instructions, see Section 3.2: Wiring.)

2.2: Input/Output Modules

The PLC Interface Module can be used with a resolver or Linear Displacement Transducer (LDT). Either input module will be located in slot 3 of the enclosure. You can identify the module type by the name found on the back of the module.

Resolver (FMIR01) Input Option R1

This module is used with a Gemco resolver. The resolver assembly consists of a highly accurate and repeatable brushless resolver, housed in an industrial-grade enclosure. The shaft position is calculated from two analog signals that vary as a function of the angular rotation of the input shaft.

The brushless resolver works on the same principle as a rotary transformer to couple power into the rotor. The construction of the brushless resolver consists of a two-phase stator and a single-phase rotor. Each stator is positioned 90° apart from each other. The two stators continually provide two different output voltages. Using these two outputs, the module performs a ratiometric conversion and provides an absolute position. This results in a highly accurate and repeatable transducer having excellent reliability with an infinite resolution which can be converted by a resolver-to-digital converter into digital position data. This module also provides the reset-to-preset input terminals. An input at these terminals will reset the position display and outputs to a preprogrammed value. This input can be used to continuously compensate for position drift caused by slippage in the drive mechanism turning the resolver.

Variable Pulse (FMIP01) Input Option V1

This module is used with an LDT that provides its output in the form of a pulse width modulated RS-422 signal. This module only works with Gemco Series 951VP2110 LDT's.

LDT Input (FMIP02) Input Option L1

This module will accept an output from a controlled pulse, start stop pulse or variable pulse magnetostrictive LDT. This card accepts a wide range of LDT inputs and provides faster updates than the variable pulse version described above.

It allows the PLC Interface Module to receive the signals from the LDT. The pulse width signal is converted to position data which the monitor displays. The module also provides +24 VDC to supply power to the LDT. The module was designed to work with the Gemco Series 951 or 952CP or RS LDT. However, other LDTs can be used with the module. If you are using a different type of LDT, contact the factory for wiring and programming instructions.

This module also contains reset-to-preset input terminals. A signal at this input will reset the position display and outputs to a preprogrammed value. This feature is useful for quick recalibration of the system to a gauge block or known machine position.

Digital Output (FMOD01) Output Option D1, D2 or D3

This module is used to transmit parallel digital output data to a PLC or personal computer. The digital output is field configurable for position or velocity data in a binary, BCD or grey code format. This data is updated every 50 microseconds. The electrical characteristics of this output data can be current sinking, current sourcing or TTL which must be specified in the module's part number.

This module also provides two input pins for use as a field configured latch or synchronized handshake input. The latch input freezes the digital output data while the PLC reads it. The data is updated when the input is released. When configured for synchronized handshake, the PLC must provide a clocked square wave input into these input pins. Digital data is updated on each transition of the square wave and the PLC is synchronized to read the updated position data after a 100 microsecond settling time.

This input accepts a 5 to 24 VDC source from the PLC to perform the latch or synchronized handshake function described above. For details on wiring to the digital output board, see pages 17 & 18.

Analog Output (FMOA01) Output Option A1

This module is used to transmit position or velocity data to a PLC in an analog format. The module provides two separate analog output channels that can be independently configured for position or velocity data.

These analog outputs can be field scaled over any range and configured for 0 - 10 VDC, 10 - 0 VDC, -10 VDC to +10 VDC, 4 - 20 mA, 20 - 4 mA, 0 - 20 ma or 20 - 0 mA.

For applications that require remote indication it is recommended to use an aftermarket analog input display or a digital input display. When using one of these displays the optional analog or digital output board must be specified in the part number.

Relay Output (FMOR01)

This optional module contains two overtravel limit relays. These relays can be programmed to either energize or deenergize upon reaching the programmed overtravel position. These relays will also actuate upon detection of the system and operating errors listed in chart A-5 in Appendix A.

2.3: Status LEDs Defined

The Interface Module has 10 status LEDs and four programming keys. The LEDs provide information on the monitor's state during machine operation, and the programming keys are used to program functions and perform basic operations.

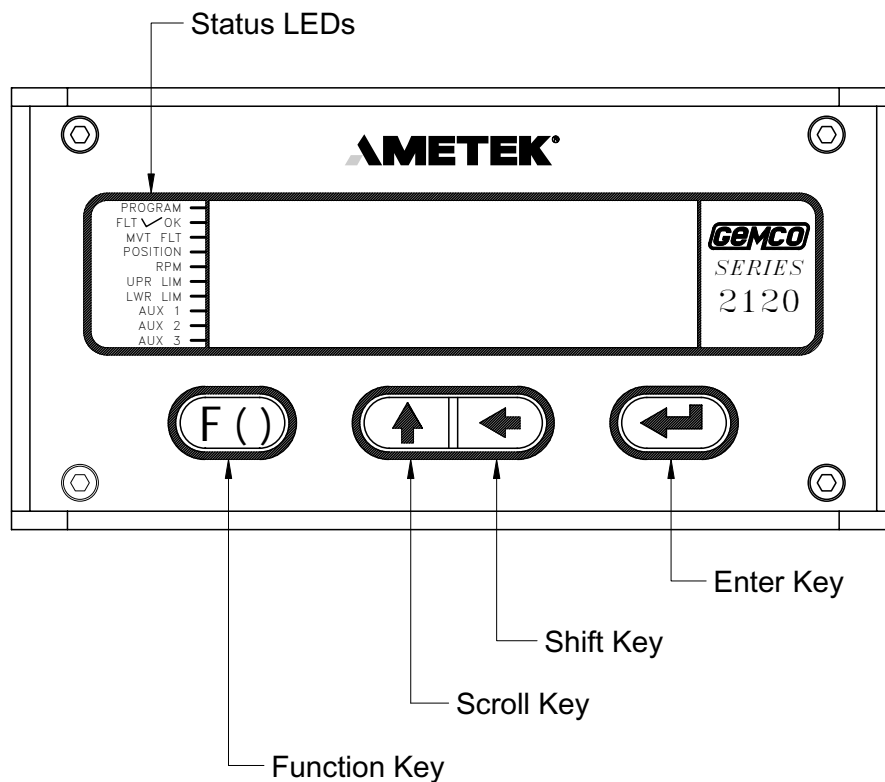





Figure 2-2 Status LEDs and Programming Keys

PROGRAM	The program LED turns on when the Interface Module is in program mode and turns off when it is not. Functions cannot be programmed when this LED is off.
FAULT ✓ OK	The fault check OK LED turns on when the power supply's fault check relay is energized, indicating the system is OK. This LED will turn off when a fault is detected, indicating that the fault check relay is deenergized.
MVT FLT	The movement fault LED turns on when a movement fault is detected. (For more information, see Move Detection Time-out in Section 4.3: Setup Functions.)

POSITION	This position LED turns on when the Interface Module is showing position in the large LED display.
RPM	The RPM LED turns on when the Interface Module is showing RPM in the large LED display.
UPR LIM	The upper limit LED reflects the state of the relay when the value programmed in the Upper End Limit function is reached. The relay can be programmed to energize or deenergize upon reaching the programmed overtravel position. (For more information, see Upper End Limit in Section 4.3: Setup Function).
LWR LIM	The lower limit LED reflects the state of the relay when the value programmed in the Lower End Limit function is reached. The relay can be programmed to energize or deenergize upon reaching the programmed overtravel position. (For more information, see Lower End Limit in Section 4.3: Setup Functions.)
AUX 1	For future expansion.
AUX 2	For future expansion.
AUX 3	The auxiliary LED is programmable and can be used with the Position Hold function. When enabled, this LED indicates when the position is being held. (For more information, see Position Hold and Auxiliary LED in Section 4.3: Setup Functions.)
	The function key is used to begin a process for programming a function. When this key is pressed, the Interface Module prepares itself for the entry of a specific function number.
	The scroll key is used to scroll through the Interface Module's list of function numbers, as well as other lists. This key is also used to increment selected digits shown on the Interface Module's LED display.
	The shift key is used to move to (select) a specific digit shown on the Interface Module's LED display from right to left.
	The enter key is selected after a function number has been entered. This begins the programming process for the selected function. The enter key is also used to program a value in a function.

NOTE: For more information on how to use the programming keys, see Chapter 4: Programming

Chapter 3: Mounting and Wiring

This chapter provides instructions for mounting and wiring the PLC Interface Module. These instructions have been divided into two sections: Section 3.1: Mounting and Section 3.2: Wiring.

Things to Consider

It is recommended that you consider the following before installing the PLC Interface Module:

- To minimize the effects of electromagnetic interference (EMI), the monitor should be mounted as far away as possible from motor starters, drives and control relays.
- The monitor should be mounted in an area free of water spray, corrosive gases, flying chips, or any other foreign matter that could cause damage to the unit.
- If the module is mounted directly on the machine, it should be installed in an area where shock and vibration will be minimized.
- The module should be located in an area that is within the temperature and humidity specifications. (See Appendix D: Specifications.)

3.1: Mounting

Interface Module

To assist you in mounting the PLC Interface Module, refer to Figure 3-1. Perform the following steps:

1. According to the dimensions as shown in Figure 3-1, cut out a section of the panel you wish to mount the module in.
2. Remove the mounting rails on the left and right side of the unit by removing the #6-32 UNC screws located on the rear of the unit.
3. Place the module in the cutout section of the panel.
4. From behind the panel, insert the two mounting rails into the module's side grooves. The feet of the rails must be inserted first. See Figure 3-1 for the location of the mounting rails.

The mounting rails secure the monitor by their feet being pressed against the back of the panel.

5. Insert each #6-32 UNC screw into each of the module's screw holes.
6. Using a 7/64" Allen wrench, secure the screws into position. This will secure the mounting rails. 8 to 10 inch pounds of torque is required.

Cabling

The signals from a resolver or LDT are inherently very immune to electrical noise. However, to ensure trouble free operation in an industrial environment, it is recommended that these cables be routed in a separate conduit isolated from all power handling leads. A continuous uninterrupted length of cable from the transducer to the Interface Module is preferred. If field splices to the cable are required, they must be done in an isolated grounded junction box with no other power handling leads present. Shielded cable must be used that has similar shielding as the standard Gemco cable and the shield must not be tied to ground anywhere along the cable run except as shown in the wiring diagram in this manual.

The cabling should also be routed away from noise generating devices like variable frequency drives, servo amplifiers, solenoid valves or large contactors.

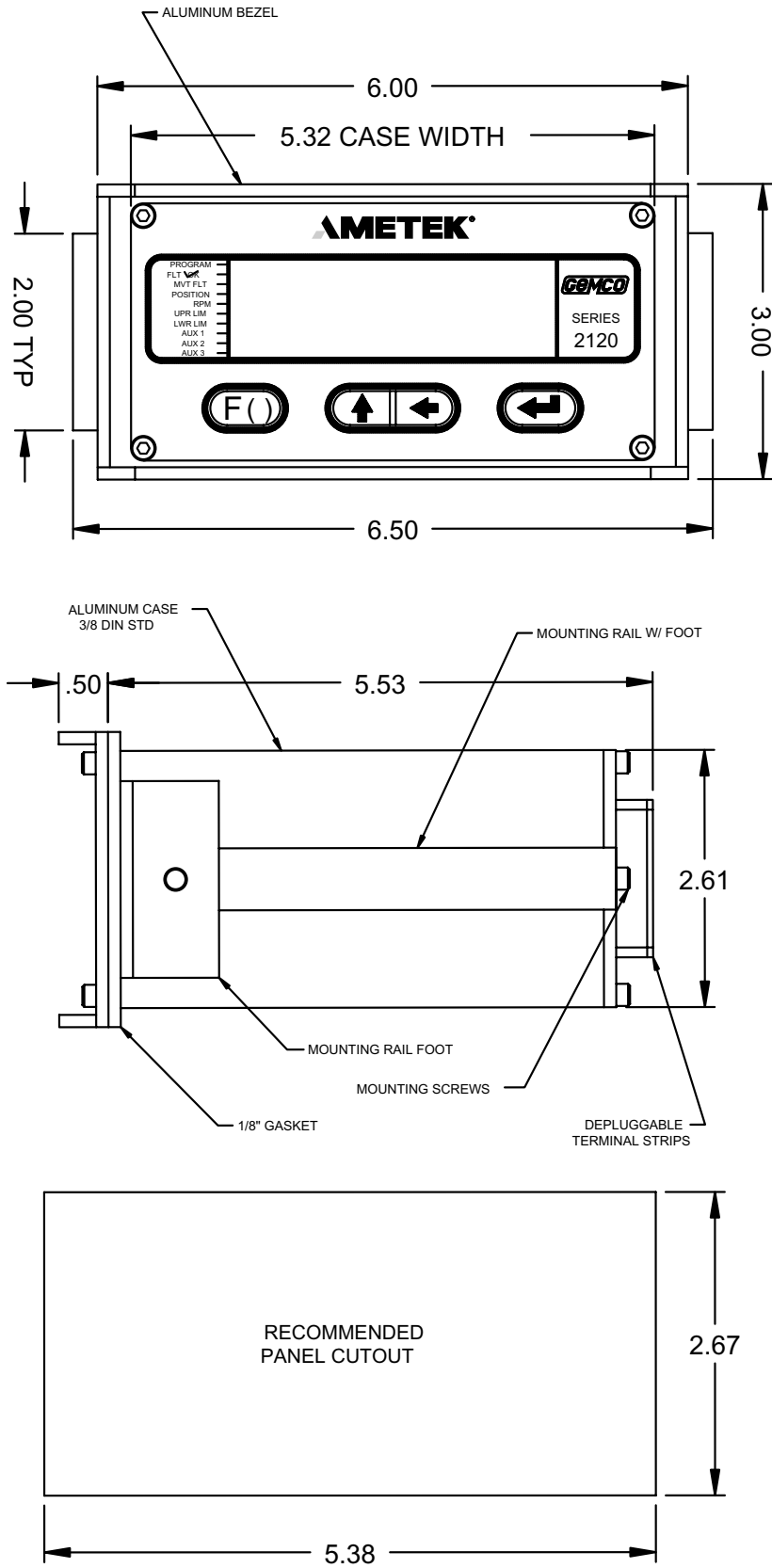

Figure 3-1 Dimensional Drawing
Drawing E0232200

3.2: Wiring

This section contains pinout diagrams for each module. System wiring diagrams follow.

Controller Module (FMMP01)

The controller has two connectors: a D9 connector (J1) for RS-232 and RS-485 serial communications, and a program lockout connector (J2) intended for a keyswitch. (See Figure 3-2). Making connections to both connectors is optional. However, the program lockout connector must be jumpered to allow the unit to enter program mode. J2's input rating is +5 VDC maximum dry contact or open collector (drain) only. Actuation voltage must be less than +1.0 VDC at 0.2 mA. The terminal wire size is No. 22-12 AWG.

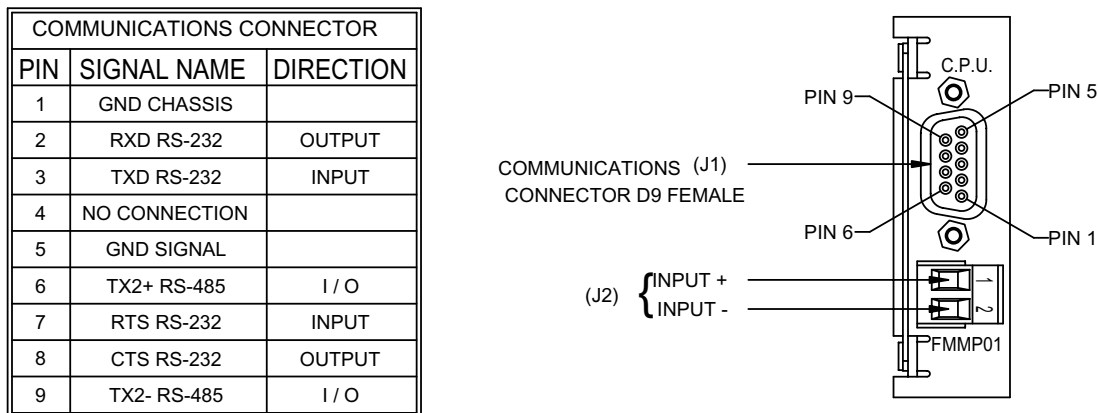

Figure 3-2 Controller Pinout Diagram
Drawing E8002099

NOTE: The controller's program lockout connector (J2) must be jumpered to allow the unit to enter program mode.

Relay Output Module (FMOR01)

The relay output module contains two overtravel limit relays. Each relay contains a N.O. contact pair and a separate N.C. contact pair. (See Figure 3-3). The relay contacts are rated at 8 amps 250 VAC, 30 VDC, 1/4 HP 125, 250 VAC. The terminal wire size is 22-12 AWG.

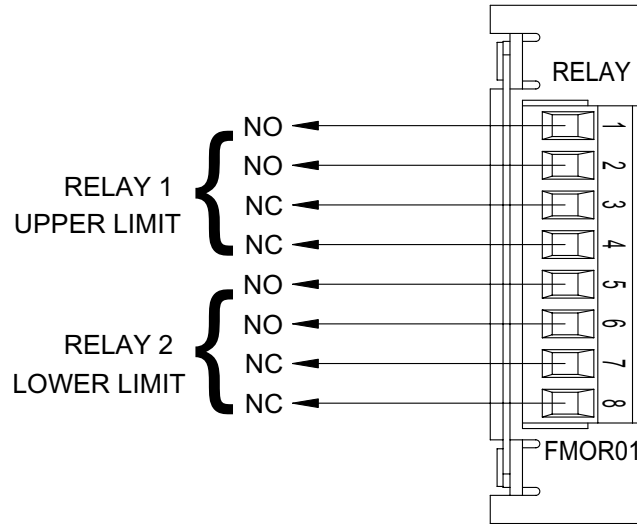

Figure 3-3 Relay Output Pinout Diagram

Power Supply Module (FMPS01)

The power supply module has a main power input, an auxiliary input, and a fault check output. (See Figure 3-4). Power input: 85-265 VAC at 450 mA maximum. Fault check output: 8 amps 250 VAC, 30 VDC, 1/4 HP 125, 250 VAC. It is recommended that the fault check contacts be connected to the required safety interlock. Auxiliary input: 85-265 VAC at 12 mA maximum. The terminal wire size for all connectors is No. 22-12 AWG. See page 3, 15 and 16 for use of this special purpose input, concerning position hold and move detection.

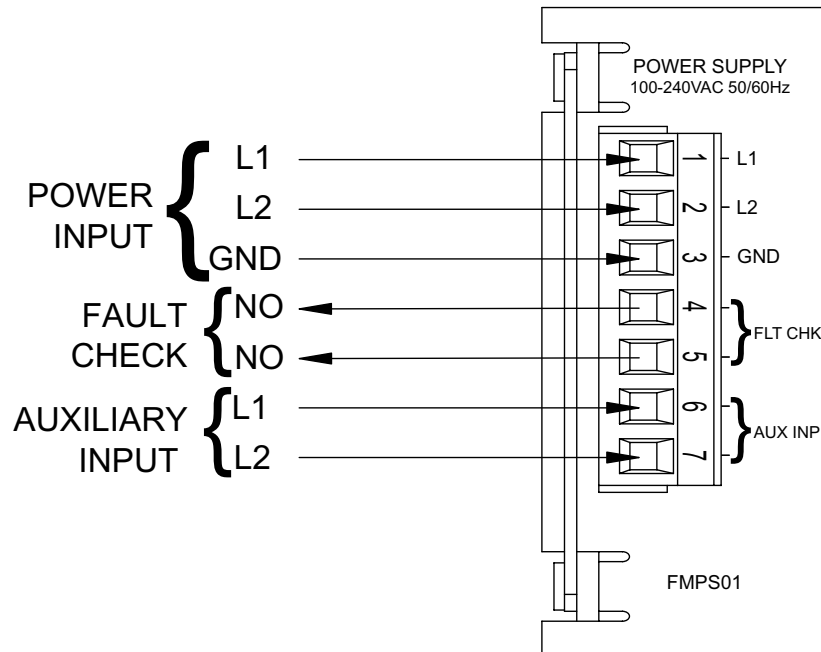

Figure 3-4 Power Supply Pinout Diagram

Resolver Module (FMIR01)

The resolver module has an eight-position connector. (See Figure 3-5). The terminal wire size for all positions is No. 22-12 AWG. The reset-to-preset input is an edge sensitive input that resets position data to a preprogrammed value. An open collector sinking device or dry contact applied to these terminals activates the input. For programming of reset-to-preset value, see Chapter 4: Programming.

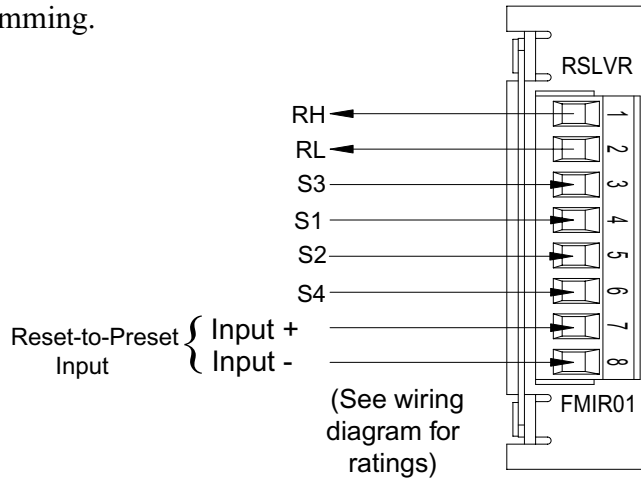

Figure 3-5 Resolver Pinout Diagram

Variable Pulse LDT Module (FMIP01) Input Option V1

The variable pulse LDT module has an eight-position connector. It is only necessary to connect your LDT to positions 1 through 4. (See Figure 3-6). Positions 1 and 2 provide +24 VDC to power the LDT. Positions 3 and 4 are used for the LDT's pulse-width output signals. These signals comprise an RS-422 differential input. Positions 5-8 are provided for future expansion. The terminal wire size for all positions is No. 22-12 AWG. This module should only be used with Gemco LDT model 951VP-2110 transducers. An open collector sinking device or dry contact applied to the Reset to Preset terminals activates the input.

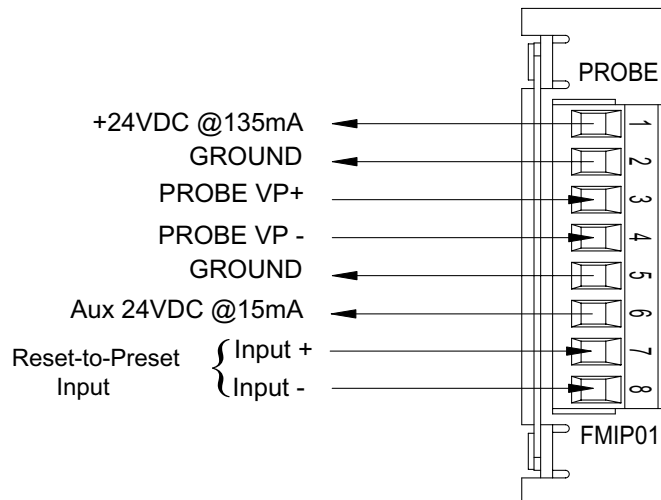

Figure 3-6 Variable Pulse LDT Pinout Diagram Input Option V1

LDT Input (FMIP02) Input Option L1

This module will accept an output from a controlled pulse, start stop pulse or variable pulse magnetostrictive LDT. (See Figure 3-7). This card accepts a wide range of LDT inputs and provides faster updates than the variable pulse module as described on page 12.

The pulse width signal is converted to position data which the monitor displays. The module also provides +24 VDC to supply power to the LDT. The monitor was designed to work with the Gemco 951 or 952CP & RS LDTs. However, other LDTs can be used with the PLC Interface Module. If you are using a different type of LDT, contact the factory for wiring and programming instructions. The terminal wire size for all positions is No. 22-12 AWG.

The reset-to-preset input is an edge sensitive input that resets position data to a preprogrammed value. A 5-24VDC source applied to these terminals activates the input. For programming of reset value, see Chapter 4: Programming.

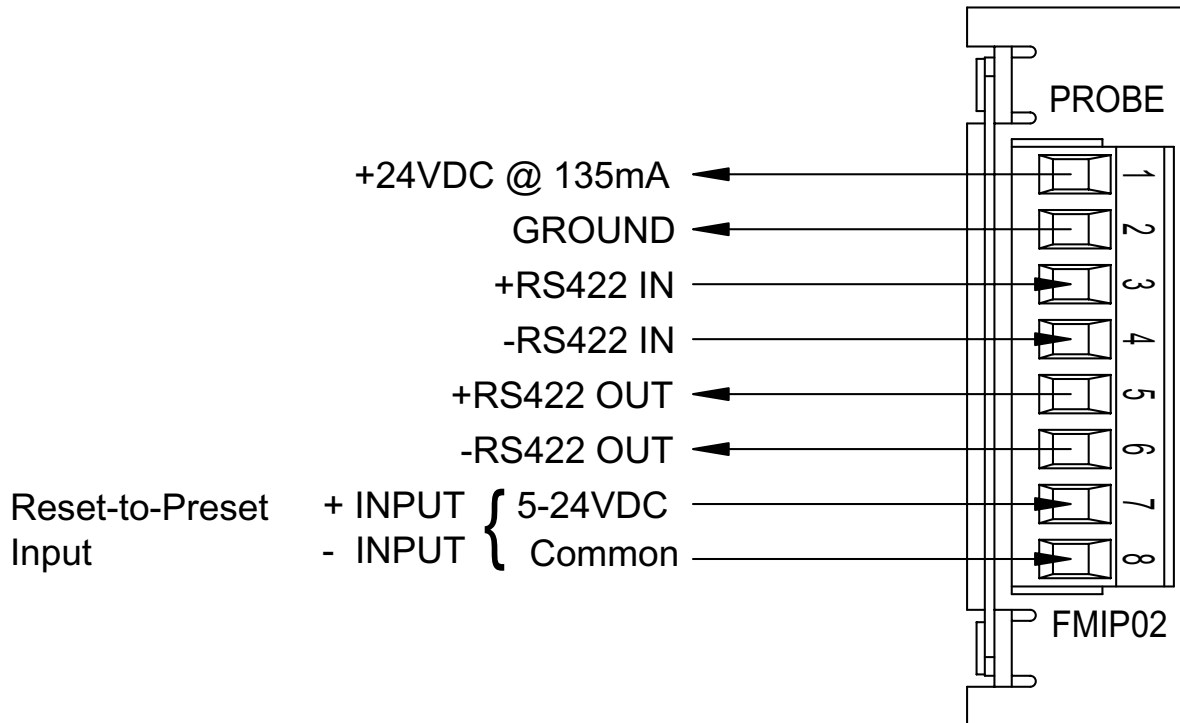

Figure 3-7 LDT Pinout Diagram Input Option L1

Digital Output (FMOD01) Output Option D1, D2 or D3

This module will output Binary, BCD, or Grey Code digital outputs in either current sinking, current sourcing, or TTL level outputs. See Fig. 3-13A & B and Fig. 3-14 for wiring details. It also contains a 5-24VDC source input for freezing the digital data while the PLC reads it. See page 37, Latch/Synchronize Handshake.

PIN	DIRECTION	DESCRIPTION
1	OUT	DATA OUT BIT 0
2	OUT	DATA OUT BIT 2
3	OUT	DATA OUT BIT 4
4	OUT	DATA OUT BIT 6
5	OUT	DATA OUT BIT 8
6	OUT	DATA OUT BIT 10
7	OUT	DATA OUT BIT 12
8	OUT	DATA OUT BIT 14/INCREMENTAL OUT Z*
9	OUT	DATA OUT BIT 16/INCREMENTAL OUT A*
10	OUT	DATA OUT BIT 18/INCREMENTAL OUT B
11	OUT	BUSY*
12	IN	BUS ENABLE*
13	IN	GND
14	OUT	DATA OUT BIT 1
15	OUT	DATA OUT BIT 3
16	OUT	DATA OUT BIT 5
17	OUT	DATA OUT BIT 7
18	OUT	DATA OUT BIT 9
19	OUT	DATA OUT BIT 11
20	OUT	DATA OUT BIT 13
21	OUT	DATA OUT BIT 15/INCREMENTAL OUT B*
22	OUT	DATA OUT BIT 17/INCREMENTAL OUT Z
23	OUT	DATA OUT BIT 19/INCREMENTAL OUT A
24	IN	SYNC
25	IN	VSRC+

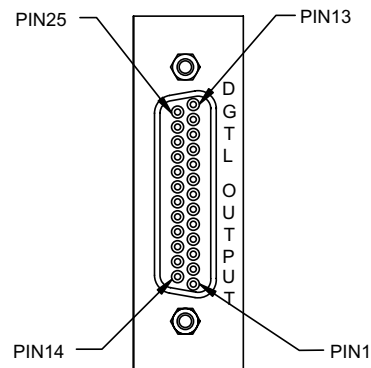
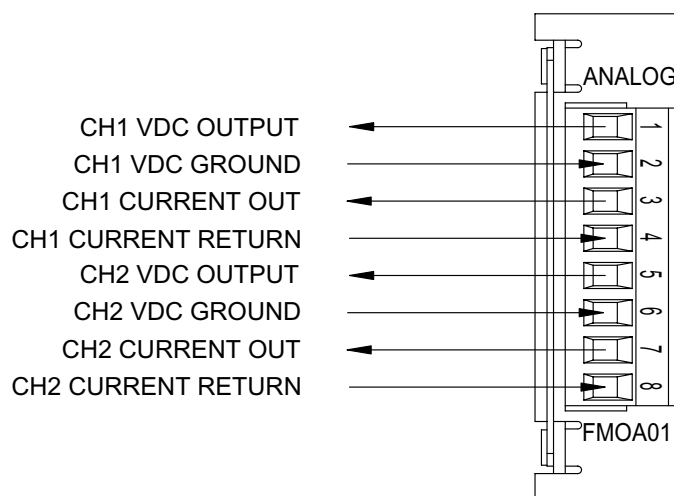

Figure 3-8 Pinout Diagram Digital Output
Drawing E8002099

Analog Output (FMOA01) Output Option A1

The Analog Output board provides two channels of analog output that can be independently configured and scaled. Each channel can be configured for an output based upon position or velocity. Velocity will be RPM if the sensor is a resolver or inches/mm per second if the input sensor is an LDT. The two channels of analog output allow you to configure one analog output to be based on position while the other channel provides a simultaneous indication of velocity.



Terminal Wire Size: No. 22-12 AWG

Figure 3-9 Pinout Diagram Analog Output
Drawing E8005099

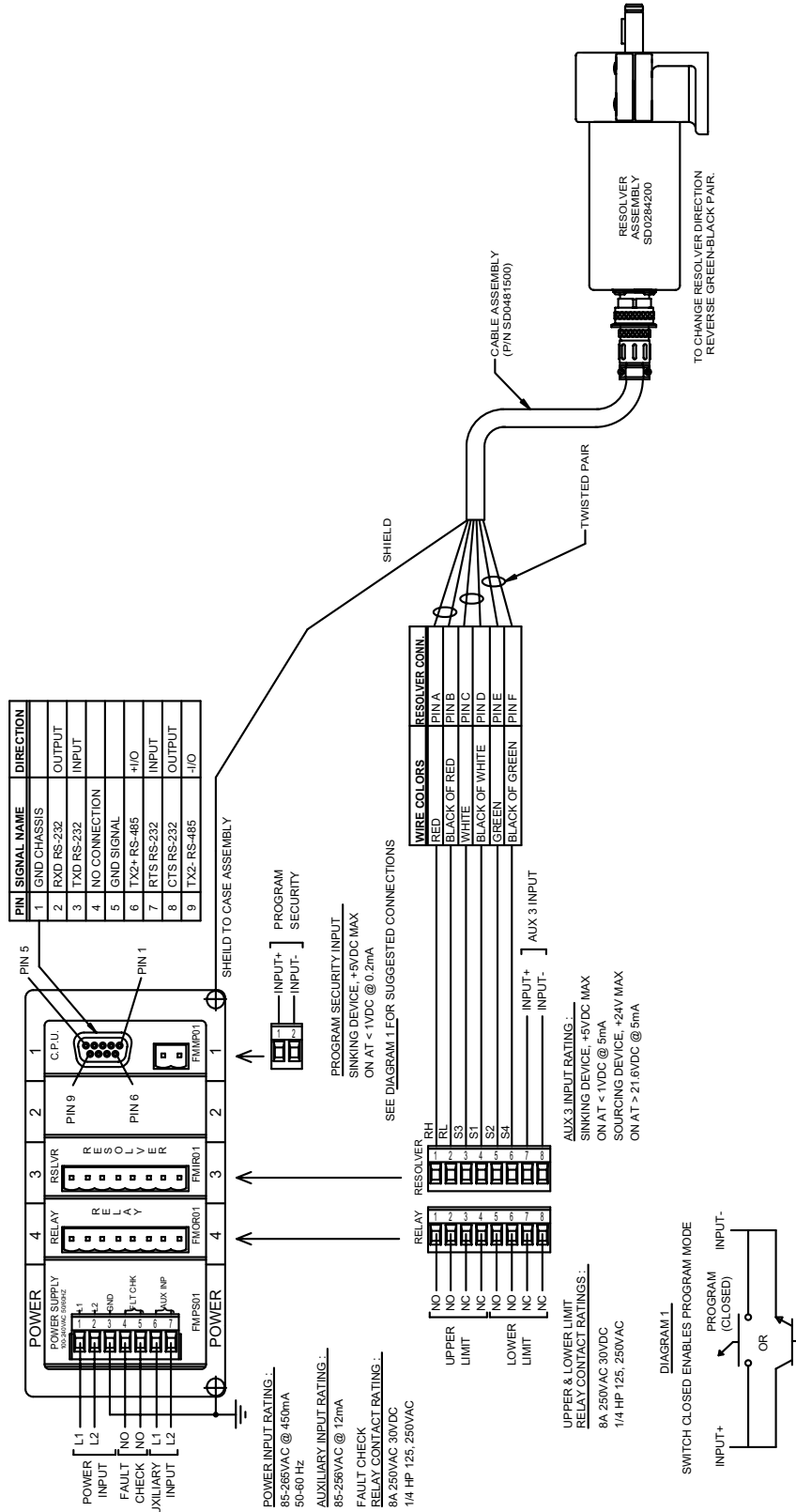

Figure 3-10 Resolver - Based System Wiring Diagram
Drawing E0235800

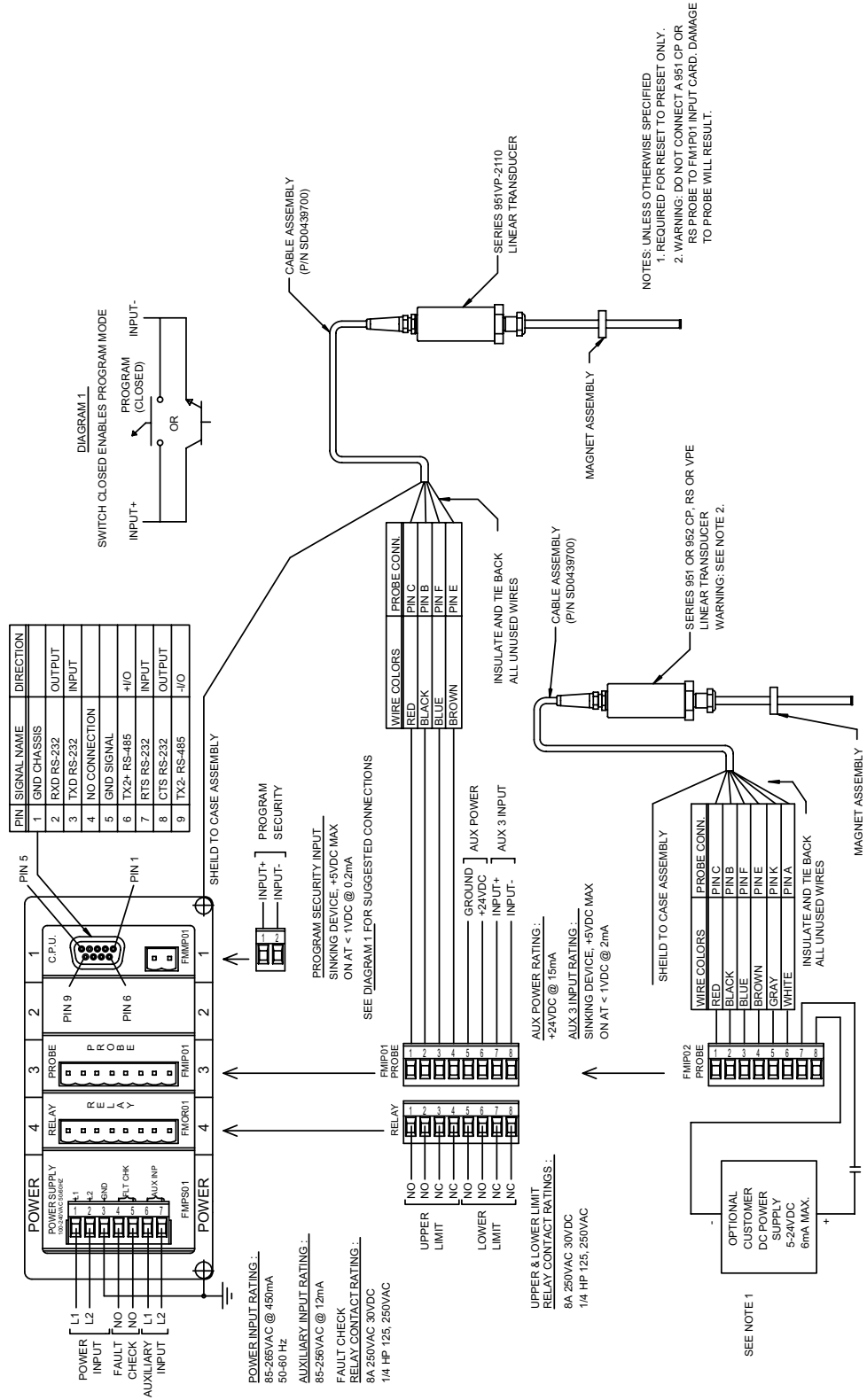

Figure 3-11 LDT - Based System Wiring Diagram

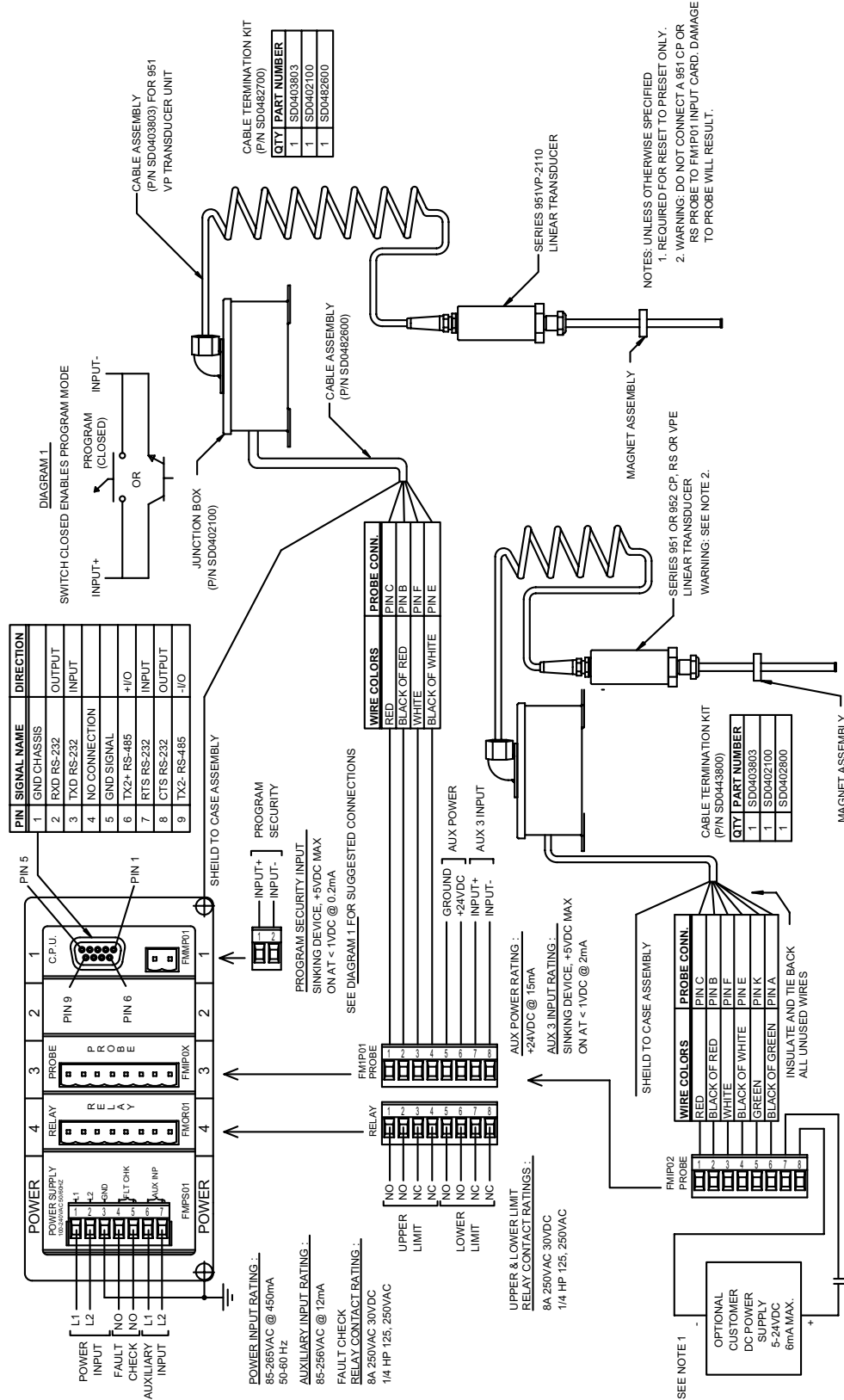
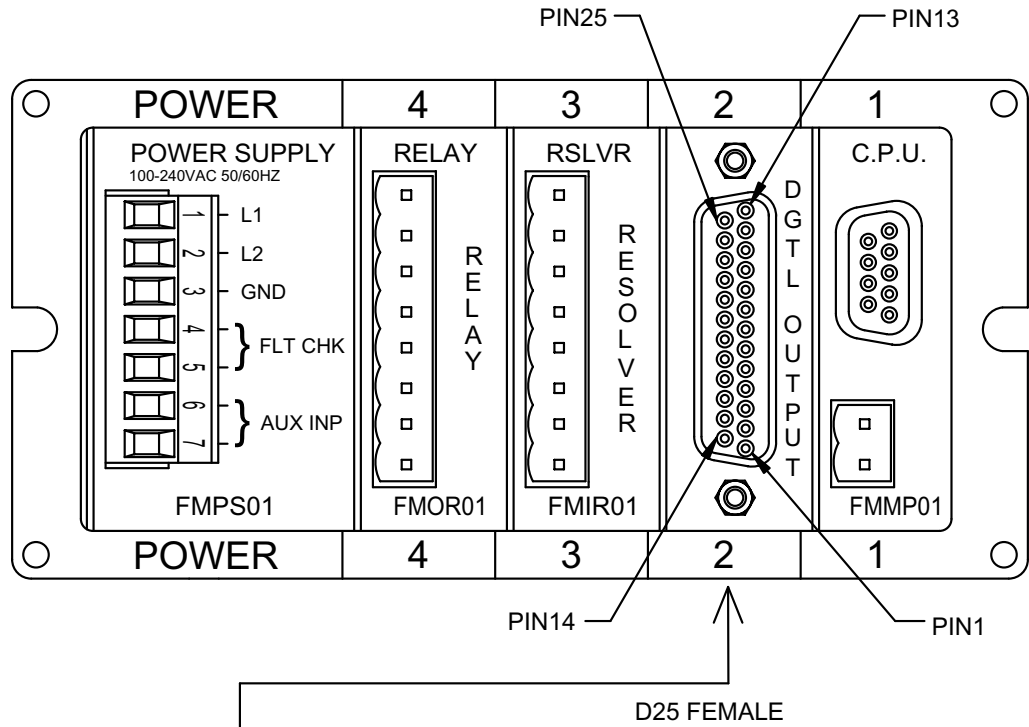

Figure 3-12 LDT - Based System w/Cable Termination Kit, Wiring Diagram
Drawing E0228600



PIN	DIRECTION	DESCRIPTION	
1	OUT	DATA OUT BIT 0	
2	OUT	DATA OUT BIT 2	
3	OUT	DATA OUT BIT 4	
4	OUT	DATA OUT BIT 6	
5	OUT	DATA OUT BIT 8	
6	OUT	DATA OUT BIT 10	
7	OUT	DATA OUT BIT 12	
8	OUT	DATA OUT BIT 14	
9	OUT	DATA OUT BIT 16	} SEE NOTE 1
10	OUT	DATA OUT BIT 18	
11	OUT	BUSY	
12	IN	BUS ENABLE (Optional, Consult Factory)	SEE NOTE 2
13	COMMON	GND	
14	OUT	DATA OUT BIT 1	
15	OUT	DATA OUT BIT 3	
16	OUT	DATA OUT BIT 5	
17	OUT	DATA OUT BIT 7	
18	OUT	DATA OUT BIT 9	
19	OUT	DATA OUT BIT 11	
20	OUT	DATA OUT BIT 13	
21	OUT	DATA OUT BIT 15	} SEE NOTE 1
22	OUT	DATA OUT BIT 17	
23	OUT	DATA OUT BIT 19	
24	IN	LATCH/SYNC HANDSHAKE	
25	POWER	VSRC+	

Figure 3-13A Digital Output Wiring Diagram
Drawing E0232200

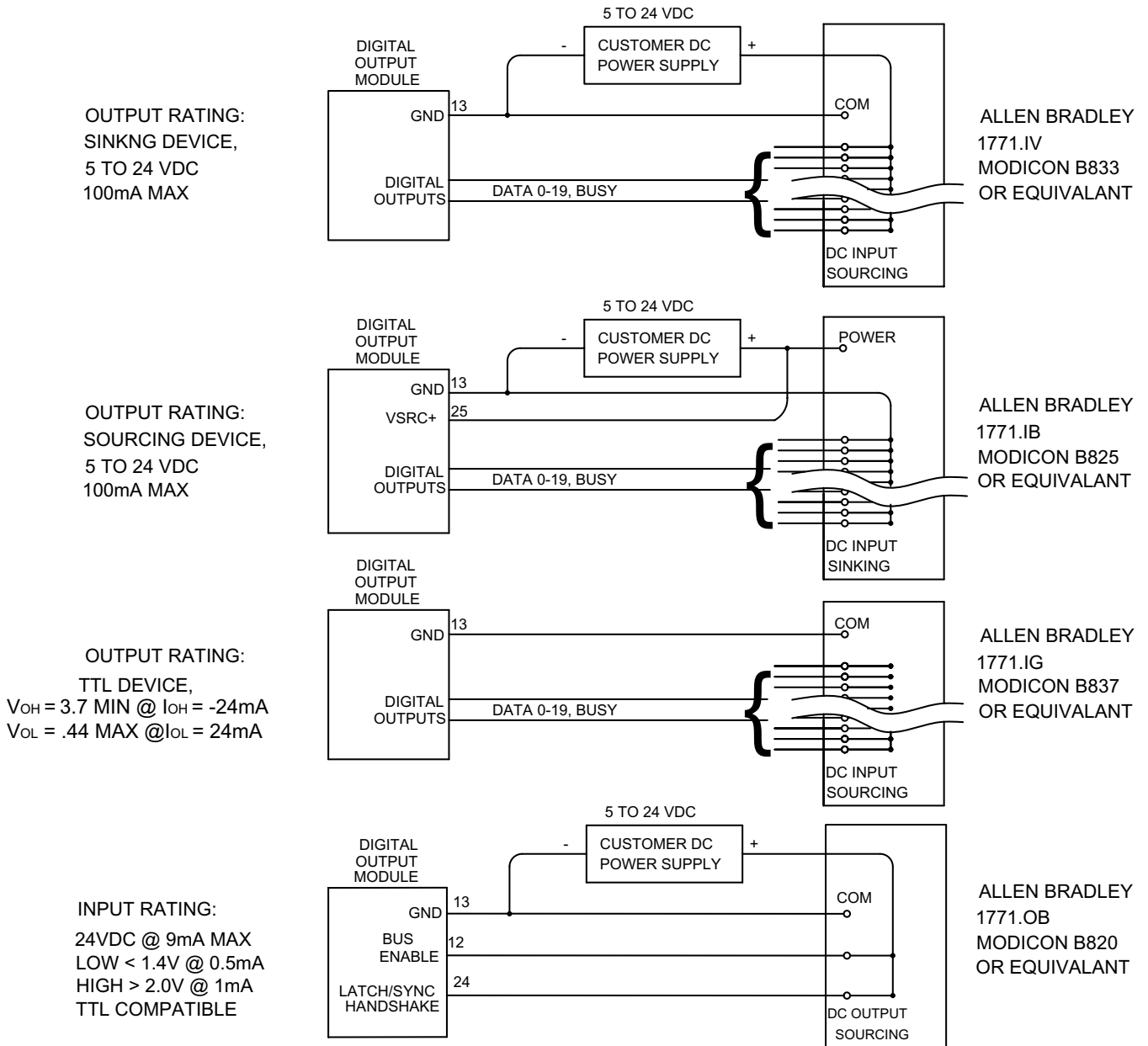

Figure 3-13B Digital Output Wiring Diagram
 Drawing E0232200

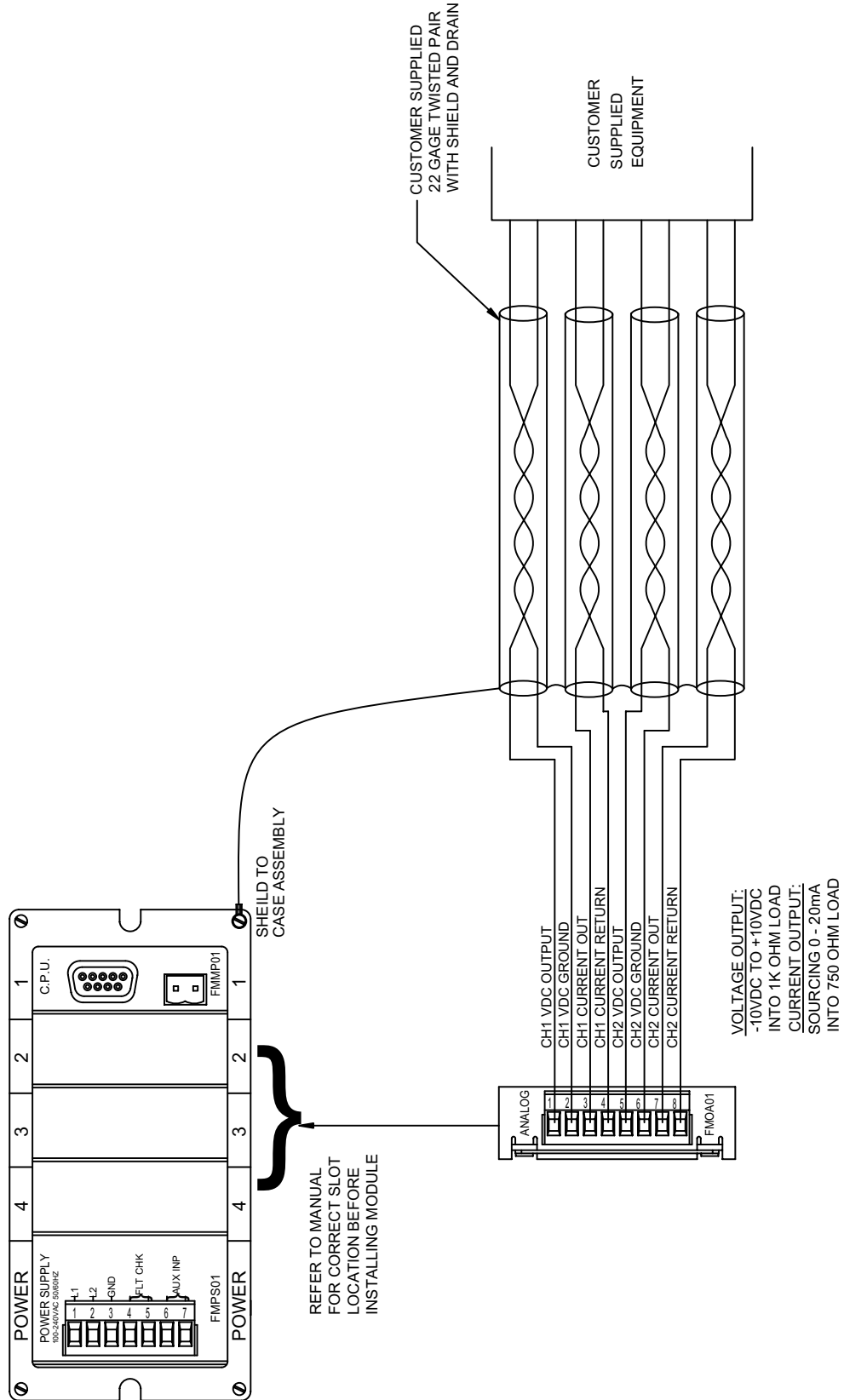

Fig 3-14 Wiring Diagram Analog Output
Drawing E8005090

Chapter 4: Programming

This chapter provides detailed descriptions and instructions for programming all Interface Module's functions. A complete list of functions (with brief explanations) can be found in Appendix B: Function Summary Chart. This chapter divides the functions into the following seven sections.

- 4.1 Resolver Input Configuration Functions
- 4.2 LDT Configuration Functions
- 4.3 Monitor Setup Functions
- 4.4 Relay Setup Functions
- 4.5 Digital Outputs
- 4.6 Analog Outputs
- 4.7 Program and Supervisory Mode Functions

Resolver configuration functions are used to configure the Interface Module for use with a Resolver. (Refer to these functions only if you are using a resolver as an input device). LDT configuration functions are used to configure the Interface Module for use with a Linear Displacement Transducer. (Refer to these functions only if you are using an LDT as an input device.) Configuration functions should be programmed before any other functions. Monitor setup functions provide the means to customize the monitor's setup for a specific installation. System setup functions provide the means to customize the Interface Module for a specific installation. Program and supervisory mode functions are used to put the Interface Module in either program or supervisory mode, as well as program the length of programming time and to change the program mode access code.

NOTE: Resolver or LDT configuration functions should be programmed first before any other type of programming is done. Refer only to your specific configuration section, depending on which input device you are using.

Before You Start

Before configuring or programming the Interface Module, the following must be done in the following order:

- Jumper the monitor's program lockout connector (J2). To jumper this connector, see Section 3.2 Wiring.
- Put monitor in program mode. For instructions on putting the monitor in program mode, see Program Mode Access in Section 4.7: Program and Supervisory Mode Functions.

The program mode LED will turn on when the monitor is in program mode.

Figure 4-1 calls out the Interface Module's programming keys. Following this figure are descriptions of these keys and how they work, as well as, a short tutorial on how to use the keys.

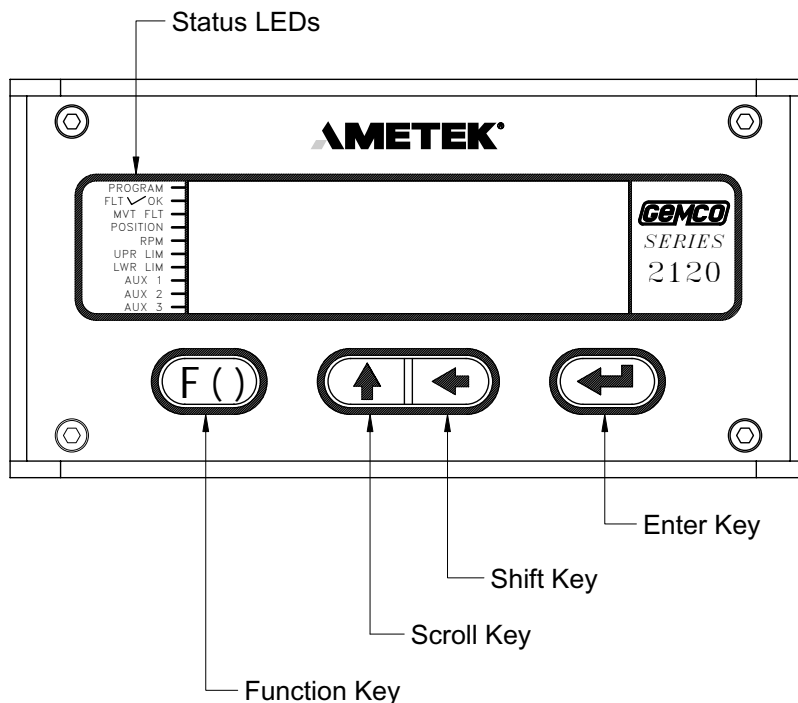

Figure 4-1 Programming Keys

Programming Keys Defined

The Interface Module has four keys located on the front panel. These keys are used to program functions and perform basic operations.



The function key is used to begin a process for programming a function. When this key is pressed, the Interface Module prepares itself for the entry of a specific function number.



The scroll key is used to scroll through the Interface Module's list of function numbers, as well as, other lists. To scroll to a particular function number, continue to select the scroll key (after selecting the function key) until the Interface Module displays the desired function number. The scroll key is also used to increment selected digits on the monitor's LED display. Incrementing digits can be done to either select a function number or a value for a function. To move to a specific digit on the display, use the shift key. A flashing digit indicates it is activated to be incremented. This key can also be used to get you quickly out of an incorrect parameter - rather than having to restart the function entry process. For example, if an invalid parameter was entered in the Upper End Limit function, you could select the scroll key. This would take the monitor back to displaying the current value, where you could re-enter a new value.



The shift key is used to move to a specific digit shown on the Interface Module's LED display. This can be done to either select a function number or a value for a function. To move to a specific digit on the display, select the function key and then the shift key. The right-most digit will then flash. This indicates that the digit is activated to be incremented. (To increment the digit, select the scroll key.) Continue to select the shift key until the desired digit is activated.



The enter key is used for several purposes. For example, it is selected after a function number is displayed. This begins the programming process for the selected function. The enter key is also used to program a value in a function. This is done by selecting the enter key after the desired value is displayed on the monitor's screen.

4.1: Resolver Input Configuration Functions

To customize the Interface Module to your specific resolver and application, you must first make some configurations. These configurations are made through the use of resolver configuration functions, which are described in this section. Perform these configuration procedures before entering other function values. After the resolver input has been configured, you may proceed on to function 305 (Display Power Up) and 307 (Resolver Reset-to-Preset).

- Scale Factor (300)
- Turns Counting (301)
- Position Offset (302)
- Turns Counting Wrap Around (308)

Scale Factor (300)

The Scale Factor function is used to program the number of counts or the resolution that one revolution of the resolver results in. For example, when the function is programmed with a value of 100, the Interface Module will count from 0 to 99 as the resolver completes a full revolution. The default value for this function is 4096.

Turns Counting (301)

The Turns Counting function defines the number of revolutions the resolver must rotate before the scale factor is reached. For example, when this function is set at 2 and the scale factor is set at 100, the resolver will have to make two full revolutions before 100 counts is reached. The Turns Counting Function can be disabled by setting its value to 0. When disabled, the scale factor will cover its entire range in one revolution and roll over to 0 after one complete revolution. When the Turns Counting function is set to 1, the total count will increase by the scale factor for each revolution. For example, if the scale factor was set at 100 and turns counting at 1, after five revolutions, the monitor would display 500 counts. The default value for this function is 0.

Turns Counting Wrap Around (308)

When using the Turns Counting software described above where the Turns Count Function (301) is set for 2 or more, you have the option of selecting the Wrap Around feature. Under normal operation, you select a scale factor using function 300 followed by the number of turns required to reach the selected scale factor using function 301. Upon reaching the selected scale factor, the count will continue to increase at the same rate if the resolver continues rotating in the same direction. With a scale factor of 100 and a turns count of 2, the module will count from zero to 100 over the first two rotations and will continue to increase by a factor of 100 for every additional two turns in the same direction. The Wrap Around function allows you to program a scale factor followed by the number of turns required to reach the scale factor. Upon reaching one digit less than the scale factor, the display and output count wraps around to zero and begins counting up at the same rate over continued rotation in the same direction.

Position Offset (302)

The Position Offset function is used to synchronize the resolver's position with the actual machine position. The default value for this function is 0. This function is used to adjust the Interface Module's indicated position so that it truly reflects the machine's position.

Programming Scale Factor (300)

This subsection provides the necessary instructions to program the scale factor. Once these steps have been performed they will not have to be repeated.



1. Select the function key.

The monitor displays "F-----".

10



2. Enter function number 10. (This is the Program Mode Access function which allows you to put the monitor in program mode. Only when the Interface Module is in program mode can other functions be programmed.) Select the enter key.

The monitor displays "000000".

NOTE: If the Interface Module displays only one zero (i.e. "0"), then the program lockout connector is not jumpered. For wiring instructions, see Section 3.2: Wiring.

Enter program mode access code

3. Enter the program mode access code. The default code is 2100. Select the enter key.



The monitor is now in program mode. The program mode LED is turned on.

NOTE: The Interface Module is defaulted to stay in program mode for 120 seconds. The monitor will drop out of program mode if a key is not pressed within this time. If this occurs, you will have to repeat steps 1-3. Further, the access code (2100) is provided initially. This code can be changed through the use of the New Access Code function. For security reasons, this function can only be implemented when the monitor is in supervisory mode. For more information on, New Access Code, contact the factory.



4. Select the function key.

The monitor displays “F-----”.

300



5. Select function number 300 (Scale Factor function). Select the enter key.

The monitor displays currently programmed scale factor.



6. Enter the desired scale factor value, including digits up to a maximum of three spaces to the right of the decimal point. Select the enter key.

Adjust the Turns Counting Factor (301)



7. Select the function key.

The monitor displays “F-----”.

301



8. Select function number 301 (Turns Counting function). Select the enter key.

The monitor displays currently programmed turns counting factor

Number
of Turns



9. Enter desired number of turns to reach scale factor. Select enter key.

Select Wrap Around Feature (308)



10. Select Function Key.

The monitor displays “F----”.

308



11. Select Function 308 (Wrap Around Feature). Select enter key.

The monitor displays 0 or 1.
0 = Wrap Around Disabled
1 = Wrap Around Enabled

Enter 0 or 1



12. Enter 0 or 1. Select enter key.

Program Position Offset (302)



13. Select the function key.

The monitor displays “F----”.

302



14. Select function number 302 (Position Offset Function). Select the enter key.

The monitor displays the current position.

Enter desired reading

15. Enter the actual or desired machine position reading. Select the enter key.



After configuring the encoder module for use with a resolver, you can proceed to Section 4.3: Monitor Setup functions.

Display Power Up (305)

This function is used to set what will be displayed on Power Up.



16. Select the function key.

The monitor displays “F----”.

305



17. Select function number 305 (Power Up Function). Select the enter key.

The monitor displays 0 or 1.
0 = Power Up Displaying Position
1 = Power Up Displaying RPM

Enter 0 or 1



18. Enter 0 or 1. Select enter key.

Resolver Reset-to-Preset (307)

The reset-to-preset input is an edge sensitive input that resets position data to a preprogrammed value. An open collector sinking device or dry contact applied to these terminals activates the input.



19. Select the function key.

The monitor displays “F----”.

307



20. Select function number 307 (Resolver Reset-to-Preset). Select the enter key.

The monitor displays current value.

Enter Desired Position 21. Enter desired Reset Value. Select the enter key.



NOTE: If 301 is set to 0, the Reset Value must be less than the Scale Factor.

4.2: LDT Configuration Functions

There are two input cards available for use with LDTs.

1. Specified as option V1 in the part number and is labeled (FMIP01) on the card.
2. Specified as option L1 in the part number and is labeled (FMIP02) on the card.

The configuration of the system is different depending on which module you have ordered. Determine which module you have and proceed to the section below for programming instructions.

Option V1 - This module can only be used with Gemco LDTs with a part number starting with 951VP1992 or 951VP2110.

Wire speed and recirculations for these LDTs have been configured at the factory for maximum resolution.

NOTE: Always refer to the LDT legend plate for programming wire speed (Function 300). The wire speed will always be between 500.000 and 600.000 micro sec./inch.

Option L1 - This module is designed to be used with any LDT with digital output. These include Series 951, 952 with VP, RS or CP outputs.

This module provides faster updates of position while using the LDT with standard wire speeds.

NOTE: Review the LDT legend plate for correct wire speed. Wire speed will always be between 8.000 and 10.000 micro sec./inch.

NOTE: If option L1 is used, the first step in configuration must be Function 307 (LDT Type), which tells the module which LDT is being used.

NOTE: Before an LDT configuration function can be programmed, the Interface Module must be in program mode. To put the monitor in program mode, see Program Mode Access in Section 4.7: Program and Supervisory Mode Functions.

Wire Speed (300)

Programming of the wire speed synchronizes the performance of the module with the performance of the LDT. You will find the wire speed on the legend plate of your LDT.

To program wire speed, perform the following steps:



1. Select the function key.

The monitor displays “F-----”.

300



2. Select function number 300. Select the enter key.

Enter new
value

The monitor displays the current wire speed.



3. Enter the new wire speed value. Select the enter key.

Count Direction (301)

The Count Direction function is used to change the direction the display counts as the LDT’s magnet travels along the guide tube. A 0 value will cause the position value to increase as the magnet moves away from the LDT head. A value of 1 will cause the position value to increase as the magnet moves toward the LDT head. The default for this function is 1. For further explanations, see Figure 4-2. To change the value of the Count Direction function, perform the following steps:



1. Select the function key.

The monitor displays “F-----”.

301



2. Select function number 301. Select the enter key.

Enter either
0 or 1

The monitor displays the function’s current value.



3. Enter either a 0 or 1. Select the enter key.

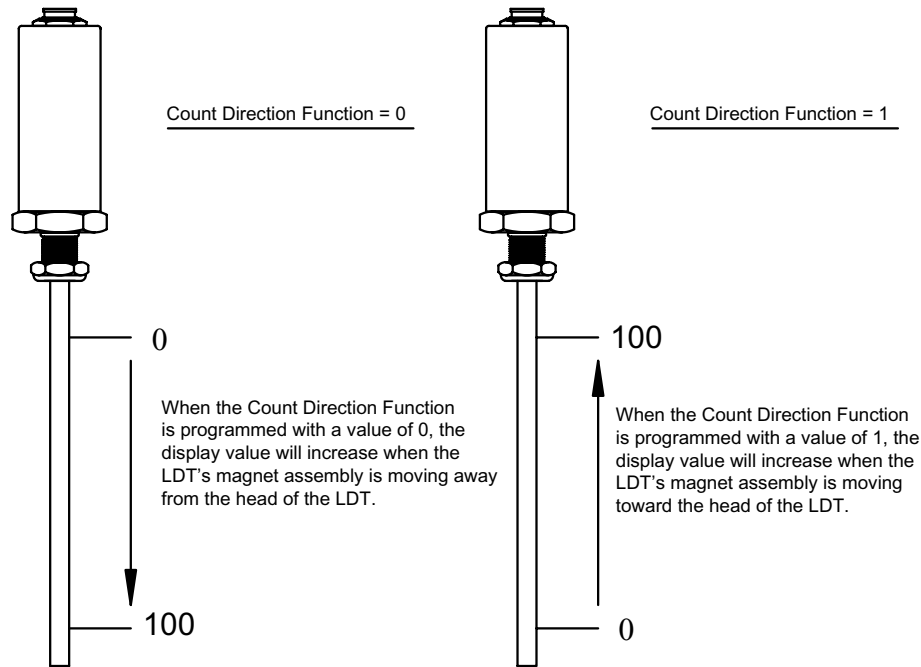

Figure 4-2 Count Direction Function Drawing

Position Offset (302)

NOTE: The display will read in inches or millimeters when used with an LDT. Make sure the unit of measurement function is selected to your desired units before entering the value for the Position Offset function. The unit of measurement is set in inches at the factory. For instructions on selecting the unit of measurement, see Unit of Measurement in Section 4.3: Monitor Setup Functions.

The Position Offset function is used to synchronize the monitors displayed value with actual machine position. This value can range from -99.999 to 999.999 inches. With the machine stationary at a known position, enter the desired position value using this function:



1. Select the function key.

The monitor displays "F-----".

302



2. Select function number 302. Select the enter key.

The monitor displays the current position.

Enter desired reading

3. Enter the new position value. Select the enter key.



Fault Pulse Time (306)

Most magnetostrictive LDTs send out a fault pulse during a fault condition. The series 2120 Interface Module is preset for use with all Gemco LDT products. The Fault Pulse Time function is used to program the pulse time of the fault signal sent by an LDT not manufactured by Gemco. When the monitor receives a fault signal of this pulse time, it will indicate an error (see Appendix A: Error Messages). The default for this function is 10 microseconds. This value can range from 1 to 99 microseconds. A 0 is entered in this function to disable it. To change the value of the fault pulse time or disable this function, perform the following steps:

NOTE: Do not change the value unless using an LDT other than Gemco.



1. Select the function key.

The monitor displays “F-----”.

306



2. Select function number 306 . Select the enter key.

The monitor displays the function’s current value.



3. Enter a 0 to disable this function or enter a new fault pulse time. Select the enter key.

LDT Output Type (307)

This function is used to configure the L1 input board for use with a specific LDT output. Review legend plate of the LDT for output type, i.e. CP, RS or VP. Perform the following steps:



1. Select the function key.

The monitor displays “F-----”.

307



2. Select function number 307 . Select the enter key.

Enter either:

0 = CP

1 = RS

2 = VP (external interrogation) (See Note below)

3 = VP (internal interrogation)*

Enter New
Value
0 thru 3



3. Select enter key.

*If used, consult the factory for additional settings.

NOTE: The Variable Pulse with external interrogation mode is not compatible with the 952 probe. When using a 952 probe, select a different mode of operation.

After configuring the Interface Module for use with an LDT, you can proceed to Section 4.3: Monitor Setup Functions.

LDT L1 Input Reset-to-Preset (311)

The reset-to-preset input is an edge sensitive input that resets position data to a preprogrammed value. A 5-24VDC source applied to these terminals activates the input.



1. Select the function key.

The monitor displays “F----”.

311



2. Select function number 311 (LDT L1 Input Reset-to-Preset Function). Select the enter key.

Enter desired
value

The monitor displays the current value.



3. Enter desired Reset-to-Preset value. Select the enter key.

4.3: Monitor Setup Functions

This section provides descriptions and instructions for the Interface Module setup functions. These functions provide the means to customize the monitor’s setup for a specific installation. Before any of these functions can be programmed, the monitor must be in program mode. To put the monitor in program mode, see Program Mode Access in Section 4.7: Program and Supervisory Mode Functions. The following is a list of the monitor setup functions:

- Unit of Measurement (14)
- Decimal Location (13)
- Position Hold (15)
- Auxiliary LED (16)

Unit of Measurement (14)

NOTE: This function applies to LDT inputs only.

The Unit of Measurement function is used to select the unit of measurement in which position data is displayed. Measurements can be either in inches or millimeters. Enter 0 to select inches or enter 1 to select millimeters. The default for this function is 0. To change the unit of measurement, perform the following steps:



1. Select the function key.

The monitor displays “F-----”

14



2. Enter function number 14. Select the enter key.

Enter either 0
or 1

The monitor displays the function’s current value.



3. Enter either 0 or 1. Select enter key.
-

NOTE: If you change the unit of measurement, the decimal location shown on the monitor’s LED display will change to the default position for the unit of measurement selected. If you select millimeters, position data will be displayed in hundredths; selecting inches will display data in thousandths. For more information, see *Decimal Location*.

Decimal Location (13)

The Decimal Location function is used to program the resolution of the Interface Module and all position data shown on the monitor’s LED display. Resolution can be either displayed in whole units, tenths, hundredths, or thousandths. Resolution choices correspond to the following values: 0 = whole unit; 1 = tenths; 2 = hundredths; and 3 = thousandths. To change the resolution shown on the monitor’s LED display, perform the following steps:



1. Select the function key.

The monitor displays “F-----”

13



2. Select function number 13. Select the enter key.

Enter either 0,
1, 2, or 3

The monitor displays the function’s current value.



3. Enter either a 0, 1, 2, or 3. Select the enter key.

Position Hold (15)

The Position Hold function stops the monitor from displaying irrelevant fluctuations during periods of high vibration at the sensor. When the monitor’s auxiliary input is activated, this function will hold the last position read. Either 0, 1, or 2 can be programmed in this function. Entering 1 will cause the monitor to hold the last position read when power is applied to the auxiliary input. Entering 2 will cause the monitor to hold the last position read when power is taken away from the auxiliary input. Entering 0 disables this function. The default for this function is 0. Enabling this function disables the Move Detection Time-Out function. When the Position Hold function is enabled, the value for the Move Detection Time-Out is then

used for the Position Hold dwell time. The position hold dwell time is the amount of time the monitor continues to hold the displayed position after the auxiliary input is released (or activated, depending on the input's programmed state). To enable or disable the Position Hold function, perform the following steps:



1. Select the function key.

The monitor displays "F-----"

15



2. Enter function number 15. Select the enter key.

Enter either 0,
1, or 2

The monitor displays the function's current value.



3. Enter either 0, 1, or 2. Select the enter key.

NOTE: The default time for the position hold dwell may be too long for your application. To change this value for your application, perform the following steps.



4. The default value for the position hold dwell time function is 5.00 seconds. To change this value, select the function key.

12

The monitor displays "F-----"



5. Enter function number 12. Select the enter key.

Enter new
dwell value

The monitor displays the current value for the position hold dwell time. This value is in seconds.



6. Enter the new dwell time. Select the enter key.

NOTE: The Position Hold function only holds the position on the monitor's LED display. Internally, the position, upper and lower limit relays, digital and analog outputs are continually being updated. In addition, the auxiliary LED can be used to indicate when a position hold occurs. However, this LED must be selected for this feature. To enable this LED, see Auxiliary LED.

Auxiliary LED (16)

The Auxiliary LED function is used to enable the monitor's auxiliary LED. This LED is currently used to indicate that the position hold input is active. (For more information, see Position Hold). Either 0 or 1 can be programmed in this function. Entering 0 will disable the LED. Entering 1 will enable the LED to turn on when a position hold occurs. The default for this function is 0. To enable or disable the auxiliary LED, perform the following steps:

1. Select the function key.
-



The monitor displays “F-----”

16



2. Select function number 16. Select the enter key.

The monitor displays the function’s current value.

Enter either 0
or 1



3. Enter either 0 or 1. Select the enter key.

Move Detection Time-out (12)

The Move Detection feature is used to monitor the time between when a signal is sent to initiate machine movement and when movement is actually detected. The default value for this function is 5.00 seconds. This value can range from 0 to 99.99 seconds. Entering a 0 disables this function. The purpose of this function is to detect a possible jam or drive component failure. When power is applied to the drive mechanism, the Interface Module’s auxiliary input is wired to receive an AC voltage. When this occurs, the Interface Module begins to look for movement. If movement is not detected within the programmed time, the upper and lower limit relays will de-energize and the fault check relay will open. Also, the movement fault LED will turn on and the monitor will display an error message (see Appendix A: Error Messages). This error will have to be cleared before machine operation can resume. To change the move detection time-out value or disable the function, perform the following steps:



1. Select the function key.

12



The monitor displays “F-----”

2. Enter function number 12. Select the enter key.

The monitor displays the function’s current value.

Enter new
time-out
value



3. Enter the new time-out value. Select the enter key.

NOTE: The power supply’s auxiliary input must be wired properly in order for the Move Detection Time-Out function to work. For instructions on wiring the auxiliary input, see Section 3.2: Wiring.

4.4: Relay Setup Functions - Option K1

If your system includes the optional relay module (K1), the following function numbers are used for setup. Before these functions can be programmed, the monitor must be in program mode.

To put the monitor in program mode, see Program Mode Access in Section 4.7: Program and Supervisory Mode Functions. The following is a list of the press setup functions:

- Upper End Limit (400)
- Lower End Limit (401)
- Relay State (402)
- Relay Override (403)

Upper End Limit (400)

The Upper End Limit function is used to program the position value at which the upper end limit relay actuates. If the displayed value reaches or exceeds the value programmed in this function, the upper limit relay and the upper limit LED will actuate. (For wiring instructions, see Section 3.2: Wiring.) The default for this function is 999.999 inches. This value can range from 0 to 999.999 inches. To program a value for the Upper End Limit function, perform the following steps:



1. Select the function key.

400

The monitor displays “F-----”



2. Enter function number 400. Select the enter key.

Enter upper
limit

The monitor displays the function’s current value.



3. Enter the new value. Select the enter key.

NOTE: To temporarily override the upper end limit relay, see Relay Override.

Lower End Limit (401)

The Lower End Limit function is used to program the position value at which the lower end limit relay actuates. If the displayed value reaches or goes below the value programmed in this function, the lower limit relay and the lower limit LED will actuate. (For wiring instructions, see Section 3.2: Wiring.) The default for this function is 0.000 inches. This value can range from 0 to 999.999 inches. To program a value for the Lower End Limit function, perform the following steps:



1. Select the function key.

401

The monitor displays “F-----”



2. Enter function number 401. Select the enter key.

Enter lower
end limit

The monitor displays the function's current value.



3. Enter the new value. Select the enter key.

NOTE: To temporarily override the lower end limit relay, see Relay Override.

Relay State (402)

The Relay State function is used to program the Interface Module's upper and lower limit relays to either energize or de-energize when their programmed value is reached or exceed. Either a 0 or 1 can be programmed in this function. Entering 0 will cause the relays to energize during normal machine operation, and de-energize when a limit is exceeded or when an error occurs. Entering a 1 will cause the relays to de-energize during normal machine operation, and energize when a limit is exceeded or when an error occurs. The default for this function is 0. To change the state of these relays, perform the following steps:



1. Select the function key.

402

The monitor displays "F-----"



2. Enter function number 402. Select the enter key.

Enter either
0 or 1

The monitor displays the function's current value.



3. Enter either a 0 or 1. Select the enter key.

Relay Override (403)

The Relay Override function is used to temporarily override end limit relays after they have actuated due to an overtravel condition. (For more information, see Upper End Limit and Lower End Limit.) To override either the upper or lower limit relays, perform the following steps:



1. Select the function key.

403

The monitor displays "F-----"



2. Enter function number 403. Select the enter key.

Enter 2110

The monitor displays "000000"



3. Enter the override code 2110. Select the enter key.

NOTE: After overriding either the upper or lower limit relays, the operator should move the machine back into its normal operating range between its upper and lower limits. If the machine is again moved in the wrong direction (towards the limits), the upper or lower limit relays will again actuate. Step 1 - 3 will have to then be repeated.

4.5: Digital Outputs

If your system has been purchased with the optional digital output module, the following programming sequence will be used to configure the board for compatibility with the PLC input card. See pages 15 and 16 for wiring details.

Output Type (200)

This function will set up the D25 connector on the digital board to output the current position value in a Binary, BCD or Gray code format:



1. Select the function key.

The monitor displays “F-----”

200



2. Enter function 200. Select the enter key.

The monitor displays the function’s current value.

Enter either
0, 1 or 2



3. Enter either 0, 1 or 2.
0 = Binary (default)
1 = BCD
2 = Gray

Select the enter key.

Latch/Synchronize Handshake (201)

This function defines which of the two methods will be used to stabilize position data while the PLC reads. The two options are Latch or Synchronize Handshake. Synchronize Handshake tells the digital board to update on the transitional edge of a clocked square wave input (pin 24). Latch tells the digital board to update continuously until the latch input pin is activated by driving it high, then the outputs will freeze. Data will immediately update to a current value upon removal of the latch input.

NOTE: If set for Synchronize Handshake, the position data will never update if a square wave input is not seen on pin 24. Allow a 100 microsecond settling time after each transition before reading the output for both the Latch and Synchronize Handshake input.



1. Select the function key.

The monitor displays “F-----”

201



2. Enter function 201. Select the enter key.

The monitor displays the function's current value.

Enter either
0 or 1

3. Enter either 0 or 1.
0 = Latch (default)
1 = Synchronize



Select the enter key.

Logic Level (202)

This function will set up selection of either high true or low true logic.



1. Select the function key.

The monitor displays "F-----"

202



2. Enter function 202. Select the enter key.

The monitor displays the function's current value.

Enter either
0 or 1

3. Enter either 0 or 1.
0 = Low True
1 = High True (default)



Select the enter key.

Error Condition Output State (203)

This function allows you to select how the digital outputs will react to a failure in the Interface Module, transducer and/or cable. The following three options describe what will happen on a failure.



1. Select the function key.

The monitor displays "F-----"

203



2. Enter function 203. Select the enter key.

The monitor displays the function's current value.

0, 1 or 2
Enter either

3. Enter either 0, 1 or 2.
0 = All Outputs Off (default)
1 = All Outputs On
2 = Last Valid Position



Select the enter key.

4.6: Analog Outputs

The Analog Output board provides two channels of analog output that can be independently configured and scaled. Each channel can be configured for an output based upon position or velocity. Velocity will be RPM if the sensor is a resolver or inches/mm per second if the input sensor is an LDT. The two channels of analog output allows you to configure one analog output to be based on position while the other channel provides a simultaneous indication of velocity.

Each of the two analog output channels generate a simultaneous voltage and current output. You can use either the current or voltage output on one channel but not both.

The following programming sequences require that you specify your intent to use either the voltage or current output for each channel prior to programming the output scaling. You can configure one analog channel for use of its voltage output and configure the other channel for current.

The analog output board will be factory installed in slot 2 or slot 4 of the Series 2120 module's chassis. Look at the back of your Series 2120 module and verify which slot your analog output board has been installed in. The following programming function numbers are shown with an "X" as the first digit. The "X" must be replaced with the number 2 or 4 which corresponds to the slot in which your analog output board was installed at the factory.

NOTE: Boards cannot be changed from their factory supplied slot location in the field.

It is recommended that you configure and program the analog output in the following sequence. Perform all programming steps for one output channel before proceeding to the other output channel.

REPLACE "X" WITH SLOT LOCATION

Analog Output Channel 1

A) Select analog output based on position or velocity



1. Select the function key.

The monitor displays "F-----"

X01



2. Enter function number X01. Select the enter key.

The monitor displays the current function value.

Enter
0 or 1

0 = position

1 = velocity



3. Leave current value or change. Select enter key.

B) Select voltage or current output

1. Select the function key.

The monitor displays “F-----”

X04

2. Enter function number X04. Select the enter key.

The monitor displays the current function value.

Enter
0 or 1

0 = voltage output

1 = current output



3. Leave current value or change. Select enter key.

C) Scaling analog output

The analog output is scaled by programming a minimum position or velocity value followed by the analog output value required at that position or velocity. A maximum position or velocity value is then programmed followed by the analog output required at that position/velocity.

The analog output value specified can be any value within the following allowable range:

Voltage	-10 VDC to +10 VDC
Current	0mA to 20mA

The analog output will stop changing upon reaching the minimum and maximum values programmed. This allows selection of a nonstandard output like 2 to 8 VDC or 10 to 20 mA.

The position/velocity range over which the analog output develops can be any portion of the total change seen by the Interface Module. This allows selection of a 2 to 8 VDC output of velocity scaled between 500 and 2000 RPM. The analog output will be 2 VDC for any RPM value below 500 RPM and will rise from 2 VDC to 8 VDC as RPM increases from 500 to 2000 RPM. The analog output will stay at 8 VDC if RPM increases above 2000 RPM.

Example: Program analog output channel 1 for 2 to 8 VDC over 500 to 2000 RPM velocity change.

1. Select Analog output of velocity as described earlier under step A.
2. Select Voltage output as described earlier under step B.
3. Select function key.



The monitor displays “F----”.

X02Enter
000500

4. Enter function number X02. Select enter key.

The monitor displays current minimum RPM value.

5. Enter 500. Select enter key. This sets minimum RPM value at 500 RPM.

The monitor displays 000500.

6. Select function key.

The monitor displays “F----”.

X05Enter
002000

7. Enter function number X05. Select enter key.

The monitor displays current voltage output value linked to minimum RPM value.

8. Enter 2. Select enter key. This sets a minimum voltage output value of 2VDC for 500 RPM or less.

The monitor displays 002000.

9. Select function key.

X03Enter
002000

10. Enter function number X03. Select enter key.

The monitor displays current maximum RPM value.

11. Enter 2000. Select enter key. This sets maximum RPM value at 2000 RPM.

The monitor displays 002000.

12. Select Function key.

The monitor displays “F-----”.

X06Enter
008000

13. Enter function number X06. Select enter key.

The monitor displays current voltage output value linked to maximum RPM value.

14. Enter 8. Select enter key. This sets a maximum voltage output value of 8VDC at 2000RPM or more.

The monitor displays 008000.

Analog output channel 1 will now provide a 2 to 8 VDC output as RPM increases between 500 and 2000 RPM. RPM values below 500 RPM will result in a 2 VDC analog output. RPM values above 2000 RPM will result in an 8 VDC output.

Analog output channel 2 is programmed using the same basic sequences except with the function numbers noted below. Remember that the X shown in the function number represents the slot in which the analog output board is installed in the Interface Module chassis.

Analog Output Channel 2 - Function numbers

- A) Select analog output based on position or velocity**
Function No. X07

- B) Select voltage or current output**
Function No. X10

- C) Scaling analog output**
 - Select minimum position/velocity value
Function No. X08

 - Select analog output value to be linked to minimum position/velocity value
Function No. X11

 - Select maximum position/velocity value
Function No. X09

 - Select analog output value to be linked to maximum position/velocity value
Function No. X12

4.7: Program and Supervisory Mode Functions

This section provides descriptions and instructions for program and supervisory mode functions. These functions are used to put the Interface Module in either program or supervisory mode, as well as, program the length of programming time and change the program mode access code. Before a function can be programmed, the monitor must be in program mode. This is done through the Program Mode Access function, which is the first function described in this section. The monitor can also be put in supervisory mode. Putting the monitor in this mode allows supervisory functions. Instructions for putting the monitor in this mode are also described in Program Mode Access. The following is a list of the program and supervisory mode functions:

- Program Mode Access (10)
- Program Mode Time-Out (11)
- New Access Code (90)

NOTE: The controller's program lockout connector (J2) must be jumpered to allow the unit to enter program mode. For wiring instructions, see Section 3.2: Wiring.

Program Mode Access (10)

The Program Mode Access function is used to put the Interface Module in either program or supervisory mode. Only when the monitor is in program mode can other functions be programmed. The monitor is defaulted to stay in program mode for 120 seconds (see Program Mode Time-Out). The monitor will drop out of program mode if a key is not pressed within this time. A program mode access code must be entered in this function in order to put the monitor in program mode. The monitor can also be put in supervisory mode. Only when the monitor is in supervisory mode can supervisory functions be programmed. A supervisory mode access code must be entered in order to put the monitor in supervisory mode. For security reasons, this code was sent separately from this manual. Contact the factory if you did not receive this code. To place the monitor in either program or supervisory mode, perform the following steps:

1. Select the function key.



The monitor displays "F-----"

10

2. Enter function number 10. Select the enter key.



The monitor displays "000000"

NOTE: If the Interface Module displays only one zero (i.e. “0”), then the program lockout connector is not jumpered. For wiring instructions, see Section 3.2: Wiring.

Enter access code



3. Enter either the program or supervisory mode access code. The default program mode access code is 2100. Select the enter key.

The monitor is now in either program mode or supervisory mode. The program mode LED is turned on.

NOTE: The Interface Module can be taken out of program or supervisory mode at any time by entering an invalid access code in the Program Mode Access function. Further, the access code (2100) is provided initially. However, this code can be changed through the use of the New Access Code function. For security reasons, this function can only be implemented when the monitor is in supervisory mode. For more information on New Access Code, contact the factory.

Program Mode Time-Out (11)

The Program Mode Time-out function is used to change the duration of time the monitor will stay in program mode once the Program Mode Access function is entered (see Program Mode Access). If a key is not pressed within the time programmed in this function, the monitor will drop out of program mode. Every time a key is pressed, the timer will restart. The default for this function is 120 seconds. This value can range from 10 to 1000 seconds. To change the program mode time-out value, perform the following steps:



1. Select the function key.

11

The monitor displays “F-----”



2. Select function number 11. Select the enter key.

Enter new time-out value

The monitor displays the function’s current value.



3. Enter the new time-out value. Select the enter key.

NOTE: The Program Mode Time-Out function serves two purposes. The first is that when the monitor is in program mode and a key is not pressed within the time-out delay, this function will take the monitor out of program mode. The second purpose is that when the monitor is displaying something other than the machine position, and is or is not in program mode, and a key is not pressed within the time-out delay, this function will force the monitor to display the current machine position.

Appendix A: Error Messages

The Interface Module displays an error message when an error occurs during machine operation. The format for errors appearing on the monitor's LED display is illustrated in Figure A-1. Descriptions and solutions for errors are provided in charts A-1 through A-3. Error messages are grouped into the following three categories:

System Error	This type of error is caused by one of the monitor's modules or input device. It typically indicates some form of a hardware failure or problem with the input device. For example, if the input device is disconnected from the input module, the monitor will display a system error.
Operating Error	This type of error is caused by problems with typical machine operation. For example, if the Interface Module does not move within the time programmed in the Move Detection Time-Out function, the monitor will display an operating error.
Entry Error	This type of error is caused by an invalid entry through the use of the monitor's keypad. For example, if an invalid function number is entered or a value for a function that is out of range is entered, the monitor will display an entry error.

NOTE: To clear errors, perform the solutions found in charts A-1, A-2, and A-3. After completing the solution, press the enter key.

Chart A-3 Entry Errors

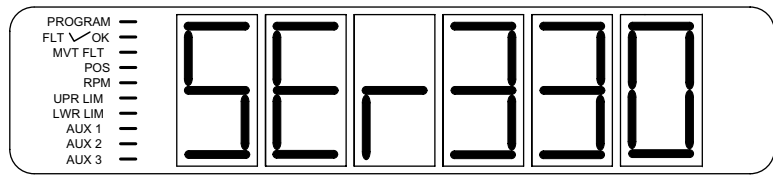

Describes the Type of Error

- SEr = System Error
- OEr = Operating Error
- EEr = Entry Error

Indicates Slot that Relates to Error*

- 1 = Slot 1
- 2 = Slot 2
- 3 = Slot 3
- 4 = Slot 4

Indicates Module that Relates to Error*

- 0 = Controller
- 1 =
- 2 = Resolver
- 3 = LDT (VP)
- 4 = LDT (CP)
- 5 = Relay Output

Indicates Error

(refer to error charts for descriptions and solutions to errors)

* For entry errors, the three right-most digits represent the particular entry error number. See Chart A-3

Figure A-1 Characteristics of an Error Message

The following charts contain descriptions and solutions for the three types of errors that can appear on the monitor's LED display. To clear errors, perform the solutions found in charts A-1, A-2, and A-3, followed by pressing either the scroll, shift, or enter.

Error Displayed	Error Description	Solution
SER101	A configuration error has occurred	Contact the factory
SER102	The monitor's function parameter memory has been corrupted	Contact the factory
SER103	The battery for the monitor's memory is low	Contact the factory
SER104	A software fault has occurred	Contact the factory
SER105	An error has occurred with the monitor's internal memory locations.	Clear error and contact factory
SER106	A firmware CRC error has occurred	Contact the factory
SER320	This is a resolver-specific error	See chart A-6
SER330	The input device is not connected to the monitor's input module	Contact the factory
SER331	This is an LDT-specific error.	See chart A-7

Chart A-1 System Errors

Error Displayed	Error Description	Solution
OEr101	The machine did not move within the time programmed in the Move Detection Time-Out function	Review machine operation and/or increase the value of the Move Detection Time-Out function
OEr330 or OEr320	The Interface Module moved beyond the value programmed in the Negative Over Travel Limit function	Review machine operation and/or increase the value of the negative Over Travel Limit function

Chart A-2 Operating Errors

Error Displayed	Error Description	Solution
EEr 1	An invalid function number was entered	Enter a valid function number
EEr 2	An invalid system configuration was entered	Enter a valid system configuration
EEr 3	A value outside the function's acceptable range was entered	Review Function's range and reenter value
EEr 4	An incorrect parameter was entered	Contact the factory
EEr 5	A value was programmed into the Lower End Limit function that is greater than the value programmed in the Upper End Limit function	Program a value that is greater than the value programmed in the Lower End Limit function
EEr 6	The value programmed into the Upper End Limit function is less than the value programmed in the Lower End Limit function	Program a value that is greater than the value programmed in the Lower End Limit function

Chart A-3 Entry Errors

The following chart contains errors that will cause the fault check relay to open:

Error Displayed	Error Description
SEr101	A configuration error has occurred
SEr106	Firmware CRC error occurred
SEr320	This is resolver-specific error. See Chart A-6
SEr330	The input device is not connected to the monitor's input module
SEr331	This is an LDT-Specific Error See Chart A-7
OEr101	The machine did not move within the time programmed in the Move Detection Time-out function
OEr330 or OEr320	The Interface Module moved beyond the value programmed in the Negative Over Travel Limit function

Chart A-4 Fault Check Relay Errors

The following errors will cause the upper and lower limit relays to de-energize:

Error Displayed	Error Description
SER320	This is a resolver-specific error See Chart A-6
SER330	The input device is not connected to the monitor's input module
SER331	This is a LDT-specific error See Chart A-7
OEr101	The machine did not move within the time programmed in the Move Detection Time-out function
OEr330 or OEr320	The Interface Module moved beyond the value programmed in the Negative Over Travel Limit function

Chart A-5 Upper and Lower Limit Relay Errors

The following chart contains a resolver-specific error:

Error Displayed	Error Description	Solution
SER320	The cable may not be connected, an open or short may exist in the cable, or the resolver's primary may be open or shorted	To determine the exact condition, enter the Error Conditions function (306). For instructions, see Error Conditions (306) following this chart

Chart A-6 Resolver-Specific Error

Error Conditions (306)

If the monitor displays “SEr320” one of four error conditions relating to the resolver has occurred. These conditions include primary open, primary shorted, S1, and S4 open or shorted. To have the monitor display the error condition which has occurred, perform the following steps:



1. Select the function key.

The monitor displays “F-----”.

306



2. Select function number 306. Select the enter key.

The monitor will display the exact condition which has occurred. The following are the possible errors:

P OPEn	(Primary Open)
P Shrt	(Primary Shorted)
S4OPEn	(S4 Open)
S1OPEn	(S1 Open)

Error Displayed	Error Description	Solution
SEr331	An error has occurred on the input device. Fault pulse received from LDT.	Correct this error by placing the magnet assembly back into the active stroke area, and clear the error.

Chart A-7 LDT-Specific Error

Appendix B: Function Summary Chart

This Appendix contains three function summary charts: B-1: General Function Summary, B-2 Resolver Specific Function Summary, and B-3: LDT - Specific Function Summary. The General Function Summary contains function summaries which apply to both a resolver and LDT based system.

Function Number	Function Name	Description
10	Program Mode Access	This function is used to put the monitor in either program or supervisory mode.
11	Program Mode Time-Out	This function is used to change the duration of time the monitor will stay in program mode once the Program Mode Access function is entered.
12	Move Detection Time-Out and/or the position Hold's dwell time	This function is used to program the time the Interface Module must move within when power is applied to the move detection input. This function also can be used to program the Position Hold function's dwell time.
13	Decimal Location	This function is used to program the resolution of the Interface module and all position data shown on the monitor's LED display.
14	Unit of Measurement	This function is used to select the unit of measurement for the Interface Module and all position data.
15	Position Hold	This function is used in applications where it is necessary to stop the monitor from updating the Interface Module display during periods of high vibration.
16	Auxiliary LED	This function is used to enable the monitor's auxiliary LED.
90	New Access Code	This function is used to change the current program mode access code.
400	Upper End Limit	This function is used to program the upper end limit of the Interface Module opening.
401	Lower End Limit	This function is used to program the lower end limit of the Interface Module opening.
402	Relay State	This function is used to program the monitor's upper and lower limit relays to either energize or de-energize when the monitor is in normal machine operation.

Appendix B: Function Summary

Function Number	Function Name	Description
403	Relay Override	This function is used to temporarily allow the operator to readjust machine position once it has exceeded a programmed end limit.
590	Software Version	This function displays the software version of your monitor.

Chart B-1 General Function

The following chart contains resolver-specific function summaries: **Resolver Input R1 Functions**

Function Number	Function Name	Description
300	Scale Factor	This function is used to program the resolver's scale factor.
301	Turns Counting	This function defines the number of revolutions the resolver must rotate before the scale factor is reached.
302	Position Offset	This function is used to synchronize displayed position with actual machine position.
305	Display Power Up	This function is used to determine what will appear on the display on Power Up.
306	Fault Pulse Time	Consult factory if using LDT other than Gemco.
307	Resolver Reset-to-Preset	This function is used to set the Resolver's Reset-to-Preset value.
308	Select Wrap Around	This function is used in conjunction with 301 (Turns Counting) and allows for the display to roll over after it's maximum count.

Chart B-2 Resolver-Specific Function Summary

The following chart contains LDT Specific function summaries: **LDT Input V1 and L1 Functions**

Function Number	Function Name	Description
300	Wire Speed	This function is used to program the wire speed of the installed LDT.
301	Count Direction	This function is used to change the direction the Interface Module counts as the LDT's magnet travels along the guide rail.
302	Position Offset	This function is used to synchronize displayed position with actual machine position.
306	Fault Pulse Time	This function is used to program the pulse time of the fault signal sent by the LDT when it detects an error.
307	LDT Output Type	This function is used to configure the L1 input board for use with a specified LDT output.
311	LDT L1 Input Reset-to-Preset	This function is used to set the LDT L1 Reset-to-Preset value.

Chart B-3 LDT Specific Function Summary

Appendix C: Catalog Numbering System

The following figure describes the catalog numbering system for the Series 2120 Interface Module. As shown, the module can be used with several different types of input and output boards. The catalog number can be found on the product sticker located on the side of the monitor.

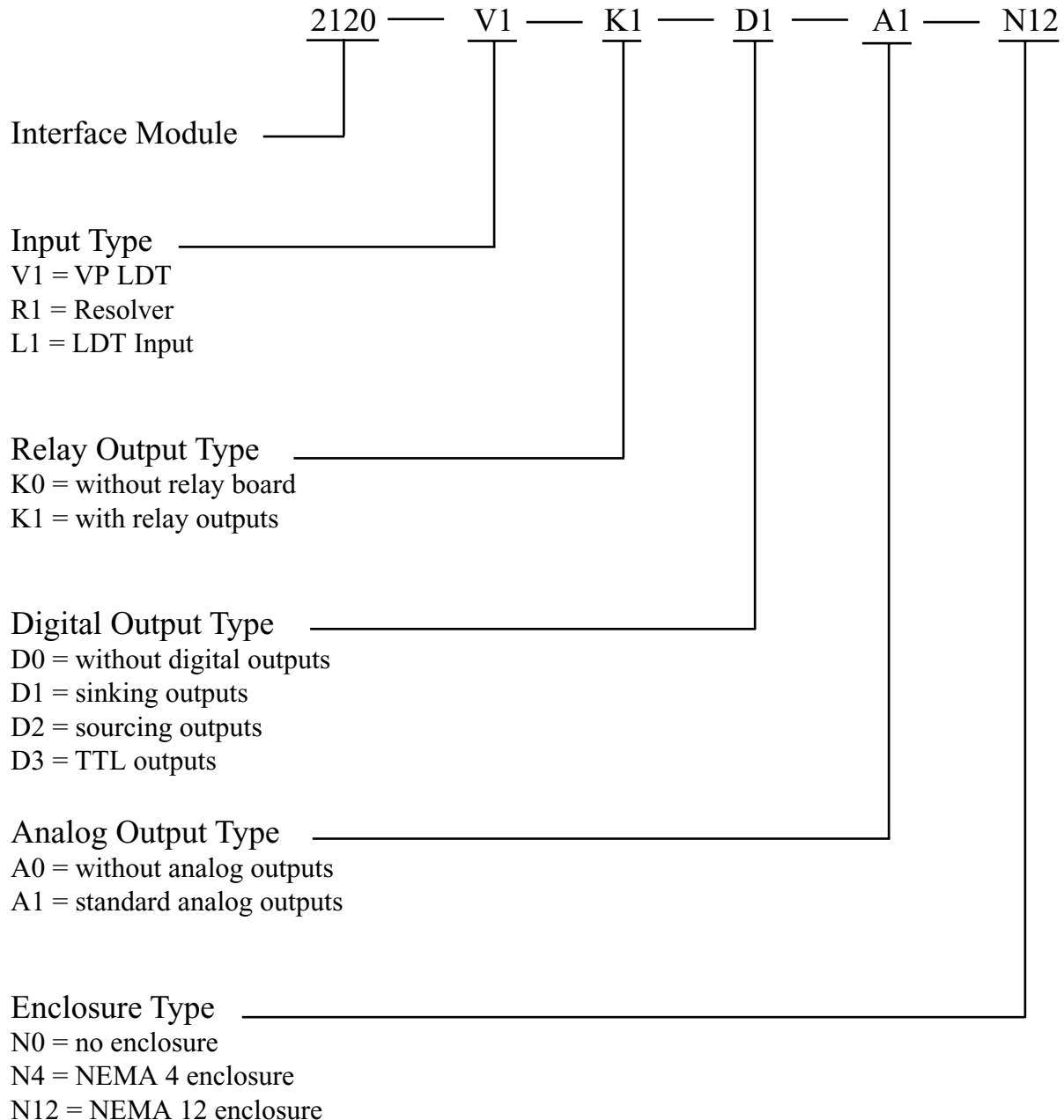

Figure C-1 Catalog numbering system

Appendix D: Specifications

Electromagnetic Rating:	IEC 801-2, Level 3 (Electrostatic discharge requirements)
	IEC 801-4, Level 3 (Electrical fast transient/ burst requirements)
Humidity:	5% to 95%, noncondensing
Memory Retention Time:	Maintains programmed values for 10 years without power.
Movement Input:	85-265 VAC (rms), 12 mA maximum; optical isolated to 3200 VDC and 2250 VAC.
Analog:	
Output Settings:	2 channels independently configurable for Voltage or Current output.
Resolution:	
Voltage Resolution	Approx. 300 μ V
Current Resolution	Approx. 0.300 μ A
Update Period:	
For configurations without Digital Outputs:	Position: 5mS Rate: 10 mS
For configurations with Digital Outputs:	Position: 20 mS Rate: 10 mS
Non Linearity:	
T = 25 C:	$\pm 915 \mu$ V $\pm 0.915 \mu$ A
Output Drift:	Less than ± 30 ppm/ $^{\circ}$ C
Voltage	100 μ Volt/ $^{\circ}$ C typical
Current	0.10 μ Amp/ $^{\circ}$ C typical
Output Isolation:	None
Output Loading:	
Voltage	± 10 V into a 1K Ω load (± 10 mA max)
Current	0 mA to 20 mA sourcing into a 750 Ω load (15V max)

Power Requirements:	85-265 VAC, 50-60 Hz., internally fused at 1.5 amps.
Program Mode Input:	Dry contact, open collector (drain) only; +5 VDC maximum, current 0.2 mA.
Relay Contact Ratings:	All relays are rated UL and CSA of 1/4 HP, 125-250 VAC; 8A 250 VAC, 30 VDC, shock resistant to 10 G.
RS-485 Output:	Up to 115.2K baud, not less than $\pm 1.5V$ into a 27 ohm load (RS-485); not less than $\pm 2.0V$ into a 50 ohm load (RS-422). Maximum cable length of 1000' using a shielded twisted pair cable (similar to a BELDEN 9481 cable)
RS-232 Output:	Up to 115.2K baud, not less than $\pm 5V$ into a 3K ohm, 2250 pF load.
Shock and Vibration:	Tested up to MIL-STD 810E, method 514.4 category 10, 20-2K Hz., at 2G sine, 0.04 G ² /Hz random and UL 491, SA19, 10-150 Hz 10G sine.
Temperature Range:	
Operating	32°F - 131°F (0°C - 55°C)
Storage	0°F - 150°F (-18°C - 66°C)
Digital:	
Output Rating:	
Sinking Device (option D1)	5 - 24 VDC @ 100mA max $V_{OL} = 1.1V$ max
Sourcing Device (option D2)	5 - 24 VDC @ 100mA max $V_{OH} = V_{IN} - 1.8$
TTL Device (option D3)	$V_{OH} = 3.7$ min @ $I_{OH} = 24mA$ $V_{OL} = .44$ max @ $I_{OL} = 24mA$
Input Ratings:	24VDC @ 9mA max Low < 1.4V @ 0.5mA High > 2.0V @ 1mA TTL Compatible

NOTE: Digital output update time increases in analog configuration from 100 to 125 μ S

Glossary

Access Code	This is a four-digit number that must be entered in the Program Mode Access function in order to put the monitor in either program mode or supervisory mode. There are two types of access codes: program mode and supervisory mode.
Calibration Functions	A group of functions used to calibrate the monitor's input device. These functions can only be programmed when the monitor is in program mode.
Controller Module	This module contains a Central Processing Unit (CPU) which is used to process data it receives from the resolver. It then shows the position of the shut height on the monitor's LED display.
Fault Check Relay	Located on the power supply module, this relay consists of a pair of N.O. contacts. During normal machine operation, this relay is energized. If an error occurs during machine operation, the controller will de-energize this relay. This relay should be wired to the machine's safety interlock.
LDT Module L1	This module is used with a Linear Displacement Transducer (LDT). This module provides +24VDC to supply power to the LDT and interface for the RS-422 output signal.
Lower Limit Relay	Located on the relay output module, this relay consists of one pair of N.O. contacts and one pair of N.C. contacts. This relay is programmable to de-energize when the machine's shut height moves below the programmed lower end limit.
Power Supply Module	This module supplies power to the monitor. It also contains the fault check relay and an auxiliary input. The auxiliary input is used for either the movement detection or position hold feature.
Program Mode	A mode of operation the monitor must be in before a function can be programmed. The Program Mode Access function is used to put the monitor in program mode.
Recirculations	The method used to improve the resolution of an LDT. The "on" time of a pulse width output is multiplied by a specified factor. This multiplication provides more counting time for the counter,

thus improving the resolution.

Relay Output Module	This module contains an upper and lower limit relay. These relays are programmable to de-energize or energize when the machine moves outside either of the relay's specified limits.
Resolver Module	This module is used with any Gemco resolver.
Supervisory Functions	A group of functions hidden from normal use and intended specifically for the equipment supervisor. For example, a function is provided to change the access code which puts the monitor in program mode. These functions can only be programmed when the monitor is in supervisory mode.
Supervisory Mode	A mode of operation the monitor must be in before a supervisory function can be programmed. The supervisory mode access code is used to put the monitor in supervisory mode.
Upper Limit Relay	Located on the relay output module, this relay consists of one pair of N.O. contacts and one pair of N.C. contacts. This relay is programmable to de-energize when the machine moves above the programmed upper end limit.
Variable Pulse Module V1	This module is used with a Linear Displacement Transducer (LDT) that operates on variable pulses, such as Gemco's 951 VP-1992 LDT. This module provides +24 VDC to supply power to the LDT and interface for the RS-422 output signal.
Wire Speed	The time it takes a pulse to travel the guide rail on an LDT. For example, a LDT set to a wire speed of 9.000 microseconds has pulses that travel its guide rail at a speed of 9.000 microseconds per inch.

Index

A

Analog Output 4
 Auxiliary LED Function 32, 50

C

Count Direction 27

D

Decimal Location Function 31, 50
 Digital Output 4
 Display Power Up 25, 51

F

Faceplate 2, 5, 21
 Fault Pulse Time Function 29, 51
 Functions
 Auxiliary LED 32, 50
 Count Direction 27
 Decimal Location 31, 50
 Display Power Up 25, 51
 Fault Pulse Time 29, 51
 LDT Input Reset-to-Preset 30, 51
 Lower End Limit 34, 35, 50, 55
 Move Detection Time-out 33, 50
 Position Hold 31, 50
 Position Offset 23, 25, 28, 51
 Program Mode Access 42, 43, 50, 55
 Program Mode Time-out 43
 Relay Override 35, 38, 51
 Relay State 35, 50
 Resolver Reset-to-Preset 25, 51
 Scale Factor 22, 23, 51
 Turns Counting 22, 23, 24
 Unit of Measurement 31, 50
 Upper End Limit 34, 50, 56
 Wire Speed 27
 Wrap Around 23, 24

G

General Hardware Components

Faceplate 2, 5, 17
 Mounting Rails 9

L

LED Aux 6
 Fault Check OK 5
 Lower Limit 6
 Movement Fault 5
 Position 6
 Program 5
 RPM 6
 Upper Limit 6
 LDT Input 4
 LDT Input Reset-to-Preset 30, 51
 LDT Output 29
 Lower End Limit Function 34, 35, 50, 55
 Lower Limit Relay 34, 35, 50, 55

M

Modules
 Standard
 Controller 3
 Power supply 3, 11
 Move Detection Time-out Function 33, 50

P

Position Hold Function 31, 32, 50
 Position Offset Function 23, 25, 28, 51
 Program Mode Access Function
 42, 43, 50, 55
 Program Mode Time-out Function 43, 50

R

Relay Output Module 5, 10, 11, 55
 Relay Override Function 35, 36, 51
 Relay State Function 35, 50
 Resolver Module 3, 12
 Resolver Reset-to-Preset 25, 51

S

Scale Factor (300) 22, 23, 51

T

Turns Counting (301) 22, 23, 24

U

Unit of Measurement Function 29, 30, 50

Upper End Limit Function 34, 50, 56

V

Variable Pulse LDT Module 4, 12, 56

W

Wire Speed Function 27, 51, 56

Wrap Around Function (308) 23, 24, 51

GEMCO

AMETEK[®]
AUTOMATION & PROCESS TECHNOLOGIES

1080 N. Crooks Road • Clawson, MI 48017 • USA
800-635-0289 • 248-435-0700 • Fax 248-435-8120
www.ametekapt.com • www.ametek.com

1145
2120.M1R1
11/01.Z11
5C