

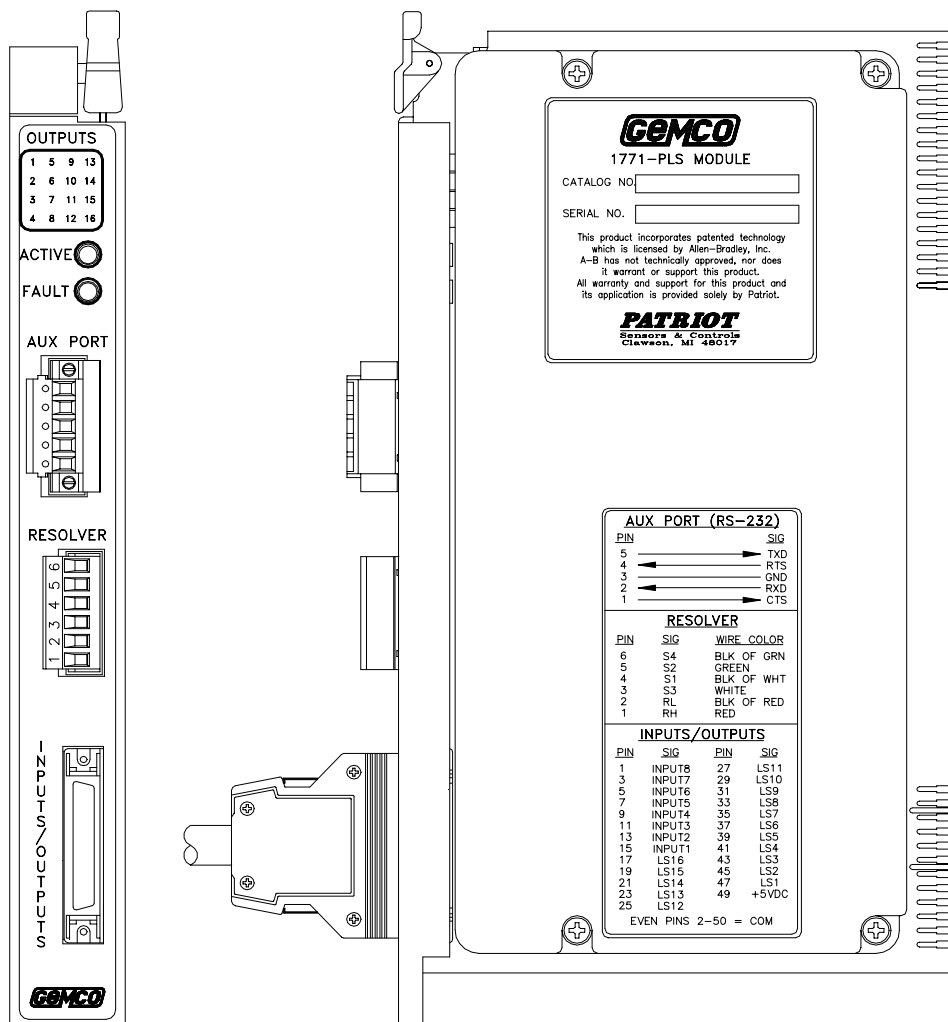

# Series 1771 PLS Gemco™

## High Speed Programmable Limit Switch

### Installation, Maintenance, and Programming Manual



**For the Allen-Bradley® 1771 I/O Chassis**



## **PATRIOT SENSORS**

1080 North Crooks Road  
Clawson, MI 48017-1097  
Phone: (248) 435-0700  
FAX: (248) 435-8120  
Internet: [www.patriotsensors.com](http://www.patriotsensors.com)

## **Preface**

---

This manual contains instructions on how to install and program the Series 1771-PLS system. Chapters 1–3 contain a hardware overview of the system’s components and instructions on how to install the system. Chapters 4–6 contain an overview of the system’s features and programming details. Troubleshooting instructions, a command summary, and specifications can be found in the appendixes.

**Copyright 1997, 1998, 1999 by AMETEK Patriot Sensors  
All Rights Reserved-Made in the U.S.A.  
Version 1.1**

AMETEK Patriot Sensors has checked the accuracy of this manual at the time it was approved for printing. Any comments you may have for the improvement of this manual are welcomed. To send comments, you can use the fax feedback form found at the end of this manual.

This product incorporates technology which is licensed by Rockwell Automation, Inc. Rockwell Automation had not technically approved, nor does it warrant or support this product. All warranty and support for this product and its application is provided solely by Patriot Sensors and Controls Corporation.

AMETEK Patriot reserves the right to revise and redistribute the entire contents or selected pages of this manual. All rights to the contents of this manual are reserved by AMETEK Patriot. Series 1771 PLS is a trademark of AMETEK Patriot Sensors. Gemco is a registered trademark of AMETEK Patriot Sensors . Allen-Bradley is a trademark of Rockwell Automation, Inc.

---

---

# Contents

<b>Chapter 1: Introduction</b>	<b>1</b>
<b>Chapter 2: Hardware Overview</b>	<b>3</b>
<b>Chapter 3: Installation</b>	<b>9</b>
<b>Chapter 4: Getting Started</b>	<b>13</b>
4.1: Things to Consider Before Programming .....	13
4.2: Initial Setup .....	14
<b>Chapter 5: Overview of Features</b>	<b>19</b>
5.1: Limit Switch Setpoints .....	19
5.2: Motion Detect Output .....	22
5.3: Linear Speed Offset .....	22
5.4: Minimum Speed Disable .....	23
5.5: Special Purpose Inputs .....	24
5.6: Input Capture .....	28
<b>Chapter 6: Programming Details</b>	<b>30</b>
6.1: Status Group .....	30
6.2: Configuration Group .....	38
6.3: Linear Speed Offset Group .....	44
6.4: Input Configuration Group .....	46
6.5: Setpoint Transfer Group .....	49
6.6: Command Group .....	52
6.7: Fault History Group .....	53
6.8: Commands .....	54
6.9: Application Examples .....	57
<b>Appendix A: Troubleshooting</b>	<b>66</b>
<b>Appendix B: Command Summary Chart</b>	<b>73</b>
<b>Appendix C: Specifications</b>	<b>74</b>
Glossary .....	76
Index .....	78

# Chapter 1: Introduction

The Series 1771 PLS is a high-speed control module that monitors rotary machine position and provides discrete limit switch outputs. These outputs are updated at a much faster rate than can be accomplished using any conventional PLC. The system provides 16 ultra high-speed outputs directly from the front panel connector, and 16 additional high-speed outputs that are fed to the backplane. Eight input channels and two I/O image table inputs are also provided. These inputs can synchronize output patterns to a product entering a workstation, disable outputs if a product is not present, and allow dynamic fine tuning of outputs from remote locations.

The PLS module resides on an Allen-Bradley 1771 backplane and is programmed through an Allen-Bradley PLC. Typical applications include controlling glue guns or actuators synchronized with a product being assembled or packaged at very high speeds. The following are features and benefits of the Series 1771 PLS:

- Output channels 1–16 are updated every five microseconds. They are accessed from the front panel connector and are typically used for direct control of glue guns or actuators. Output channels 17–32 are internally updated every 500 microseconds and can be fed into the I/O image table. Multiple on/off dwells are available on all output channels.
- The 24-channel I/O module rack provides optical isolation between the PLS module and the industrial environment. The 16 output and eight input relays use industry standard AC or DC solid-state control relays.
- The two additional I/O image table inputs act in the same way as the inputs found on the I/O module rack, but come through the PLC's I/O image table.
- Linear speed compensation or run-up control allows output channels to be selected and programmed to automatically advance or retard as machine speeds vary. This compensates for the mechanical lag in glue guns or actuators to precisely synchronize control functions with the product moving through a machine. Typical applications involve controlling glue gun output patterns during machine startup. This feature also allows for different rates of advance on the leading and trailing edge of the setpoint dwell to compensate for differences in the actuators turn on and turn off times.
- Minimum speed disable functions allow selected output channels to become disabled upon machine RPM dropping below a programmed value. Output channels using this feature will turn off during an emergency stop condition to retract actuators to a safe position or stop glue guns even though a product is positioned under the glue station.
- Reset to preset inputs can be programmed to reset field selected output

channels to zero or some other value upon actuation of the input. Typical uses involve synchronizing groups of output channels with the leading edge of a product entering a workstation. A photoelectric or proximity switch is used to sense the leading edge of the product. The switch's output is wired to a reset to preset input to reset a group of output channels to zero which begin operating based on their programmed setpoints in relation to the product. All reset to preset inputs can be used simultaneously and will work independently of each other with each input resetting a different group of output channels. Output channels linked to these inputs can operate in two modes: standard and single shot. For more information on these modes, see Section 5.5: Special Purpose Inputs.

- Output enabler inputs can be programmed to enable or disable selected groups of output channels based on sensing the enable input prior to the start of the output pattern. This input is used to enable the outputs only upon seeing a critical event prior to beginning a cycle (one-shot mode), or when the input is “on” (level mode). For more information on these modes, see Section 5.5: Special Purpose Inputs.
- Remote setpoint tuning inputs can be used to advance or retard a pre-selected group of up to 16 ultra high-speed output channels from a remote location. Actuation of the advance input will move all setpoints on the selected output channels forward in a predefined (programmable) increment. Actuation of the retard input moves these same setpoints backward in a predefined (programmable) increment. Operators can watch these changes and make small adjustments to the outputs while standing at the workstation where the actuators are located.
- A 50-pin parallel cable is provided to quickly connect the I/O module rack to the PLS module.
- Special stitching-pattern programming sequence simplifies system setup.
- Input capture registers ensure that critical events occur at correct points in the process sequence.
- Front panel auxiliary port allows the PLS module to be connected to a Gemco keypad or PC.
- All configuration and setpoint data can be saved using the Save command (40). This information is saved to nonvolatile memory.

# Chapter 2: Hardware Overview

This section contains mechanical and electrical information on the Series 1771-PLS module, I/O module rack, and resolver assembly. For further information, see Appendix C: Specifications.

## PLS Module

The PLS module is an electronic assembly that plugs into an Allen-Bradley 1771 I/O chassis. Figure 2-1 illustrates the PLS module. The following are features found on the module's faceplate:

- An ejector handle at the top simplifies installing and removing the module from the chassis.
- Sixteen LEDs correspond to the state of the 16 ultra high-speed output channels. When an LED is on, the output channel it corresponds to is energized. When an LED is off, the output channel is de-energized.
- The active and fault LEDs display the system's state. The active LED will turn on when the PLS module is operating normally. The fault LED will turn on when an error occurs during machine operation. Errors prevent the output channels from operating. For more information on how to determine the type of error, see Section 6.1: Status Group.
- The auxiliary port is currently not available for customer use. Contact factory for special applications.
- Resolver input terminals allow connection to a Gemco resolver assembly or compatible equipment.

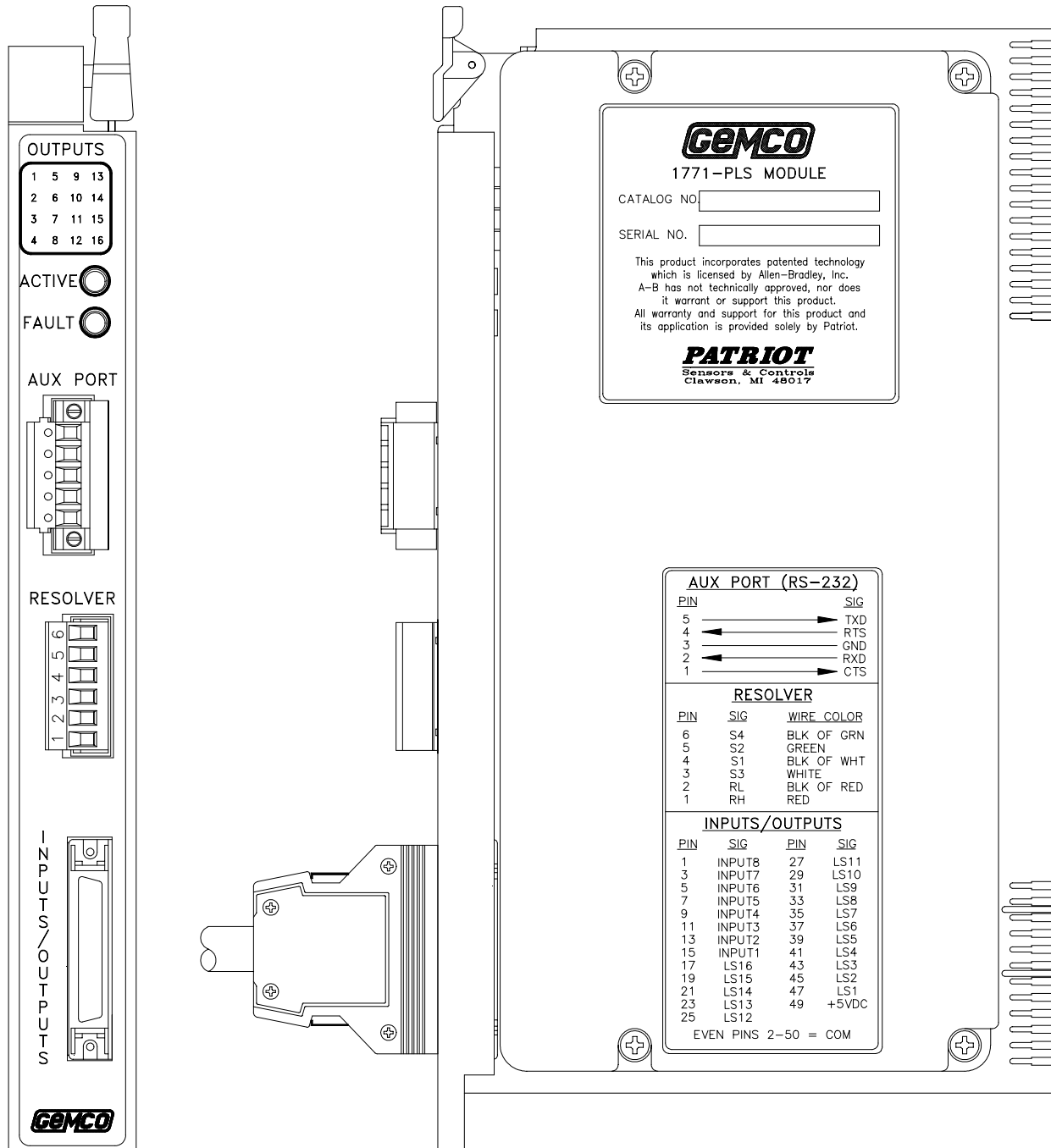

Figure 2-1 PLS Module

**NOTE:** To reverse the resolver count direction from clockwise to counterclockwise, switch resolver's black of green wire with green wire.

## I/O Module Rack

The I/O module rack consists of 16 output modules and eight (8) input modules. These modules provide an optically isolated barrier between the PLS and the field devices they control. These modules are also pluggable and can be selected as either AC or DC. Figure 2-2 illustrates the I/O module rack and the circuitry of its I/O modules. The following is a list of items describing the components of the I/O module rack:

- The I/O modules can be ordered through Patriot Sensors & Controls or Grayhill, Inc. According to Grayhill's catalog No. 1, revised edition 0295, Grayhill's part numbers are 70M-OAC5 (AC output), 70M-ODC5 (DC output), 70M-IAC5 (AC input), and 70M-IDC5 (DC input). See Appendix C: Specifications for Gemco part numbers.
- The I/O module rack is connected to the PLS module using a Gemco 50-pin cable (P/N SD0495800) or equivalent.
- LEDs are located next to each I/O module. These LEDs specify the state of each module.



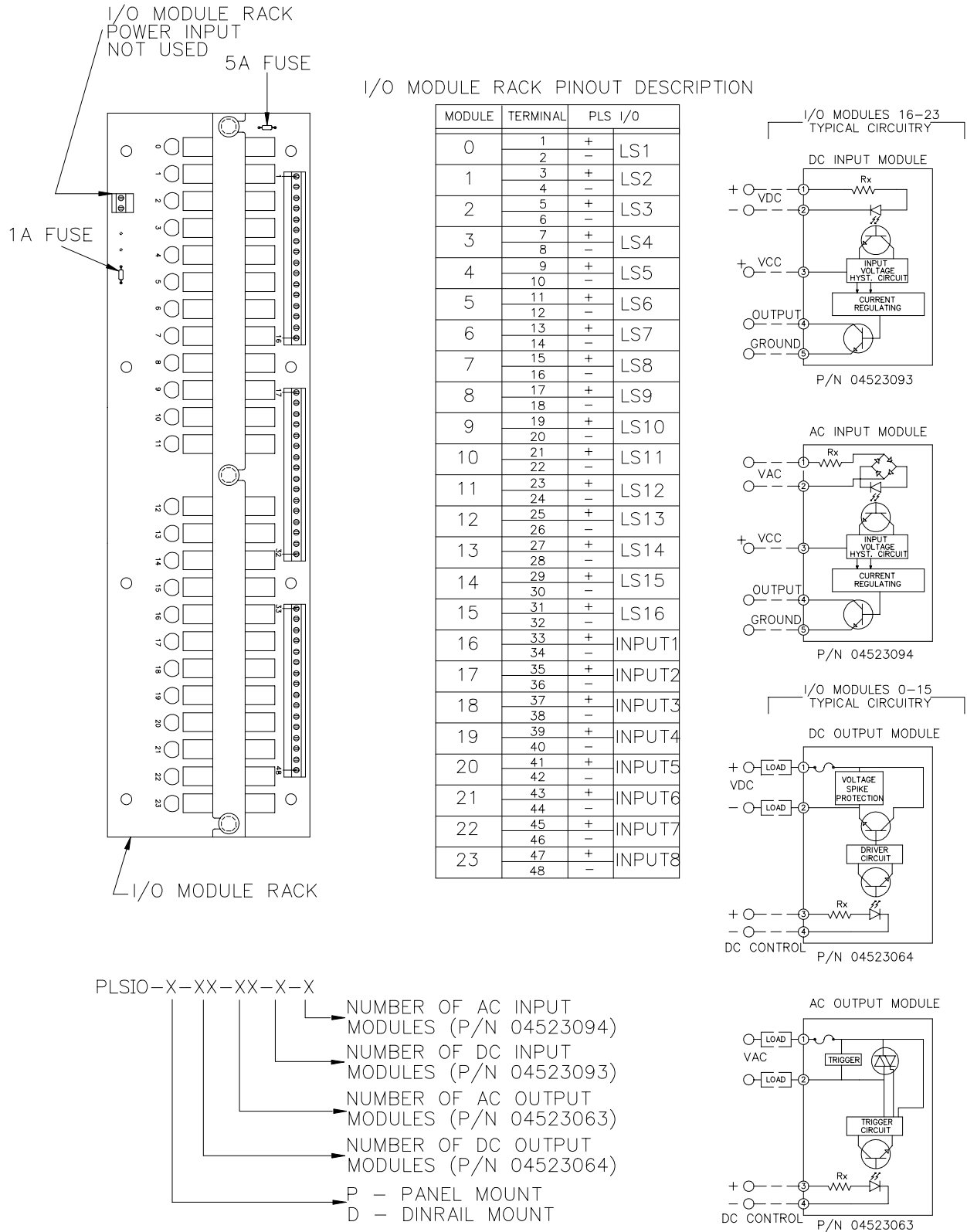

Figure 2-2 I/O Module Rack and Circuitry of I/O Modules

## Resolver Assembly

The resolver assembly consists of a highly accurate and repeatable brushless resolver, housed in an industrial-grade enclosure. Rotary shaft position is calculated from two analog signals that vary as a function of the angular rotation of the input shaft.

The brushless resolver works on the same principle as a rotary transformer to couple power into the rotor. The construction of the brushless resolver consists of a two-phase stator and a single-phase rotor. Each stator is positioned  $90^\circ$  apart from each other. The two stators continually provide two different output voltages. Using these two outputs, the PLS performs a ratiometric conversion, which factors out electro-magnetic interference (EMI) and provides an absolute position. See Figure 2-3. This results in a highly accurate and repeatable resolver having excellent reliability with an infinite resolution which can be converted by a specialized analog-to-digital converter into digital position data.

The resolver assembly is contained in a rugged NEMA 4 enclosure with a plug-in connector. The input shaft is  $3/4$  inches in diameter and is made of stainless steel. It is mounted in sealed ball bearings having a radial load rating of 450 lbs. This results in the most rugged-duty transducer available for industrial applications. The operating temperature range is  $-50^\circ\text{C}$  to  $125^\circ\text{C}$ . See Figure 2-4 for the resolver's dimensions.

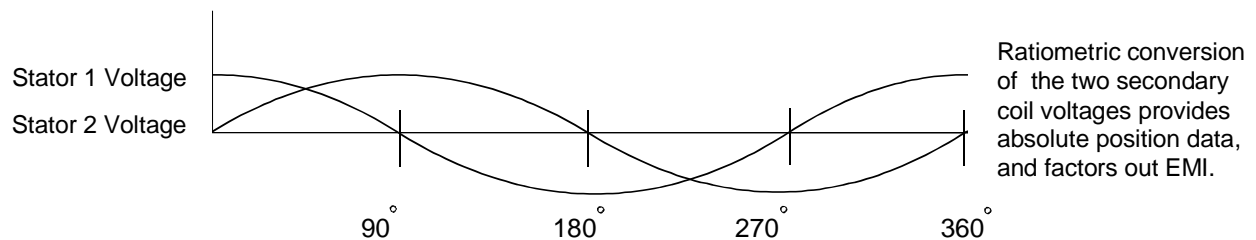

**Figure 2-3** Voltages of Stator Coils

---

**NOTE:** Other resolver assemblies are available from Patriot Sensors & Controls; contact factory for details.

---

**NOTE:** It is possible to have multiple slave 1771-PLSs attached to the same resolver. Factory tests have indicated that at least ten 1771-PLSs connected to the same resolver, using short cable lengths (approximately 100 feet or less) function properly. The resolver fault check circuitry indicates a fault condition when the slave device, or devices, is separated from the master 1771-PLS's cable link. See Chapter 3: Installation for additional information.

---

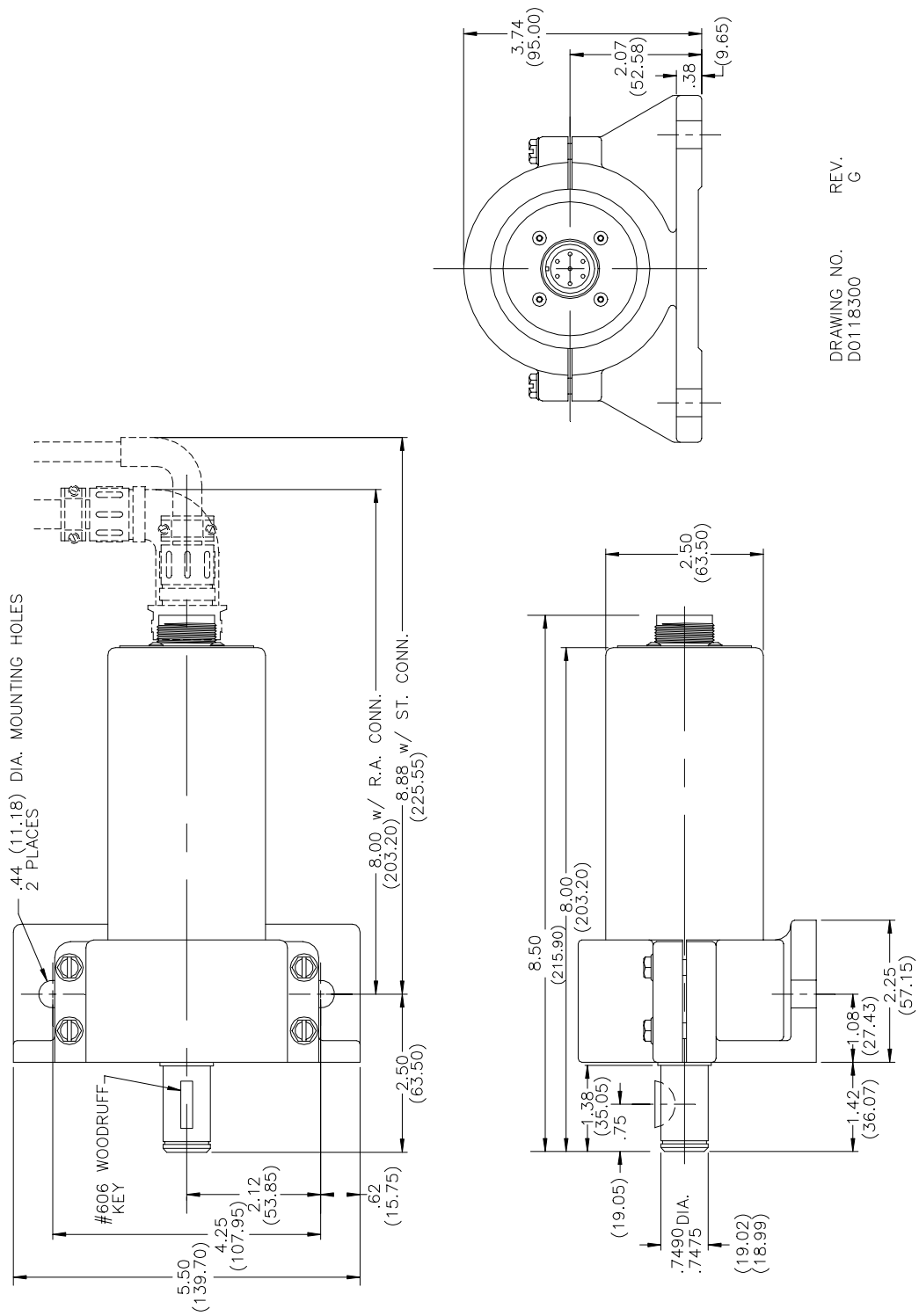

DRAWING NO. D0118300  
REV. G

Figure 2-4 Brushless Resolver

# Chapter 3: Installation

This chapter contains instructions on how to install the Series 1771 system. This includes installing the PLS module into the 1771 I/O chassis and connecting the PLS module to the I/O module rack and resolver assembly.

Before inserting the PLS into the I/O chassis, the module's dipswitch (SW1) must be configured. (See Figure 3-1.) The dipswitch has four switches. The positions of switches 1 and 2 determine the addressing mode. The addressing mode configuration must match the settings of the 1771 I/O chassis. The position of switch 4 determines if the PLS will act as Master (module drives a reference signal to the resolver) or Slave. If there is one PLS module connected to a resolver, it must be configured as a master. When daisy-chaining multiple PLSs, only one module (master) can drive a reference signal to the resolver. Switch 3 is not used at this time.

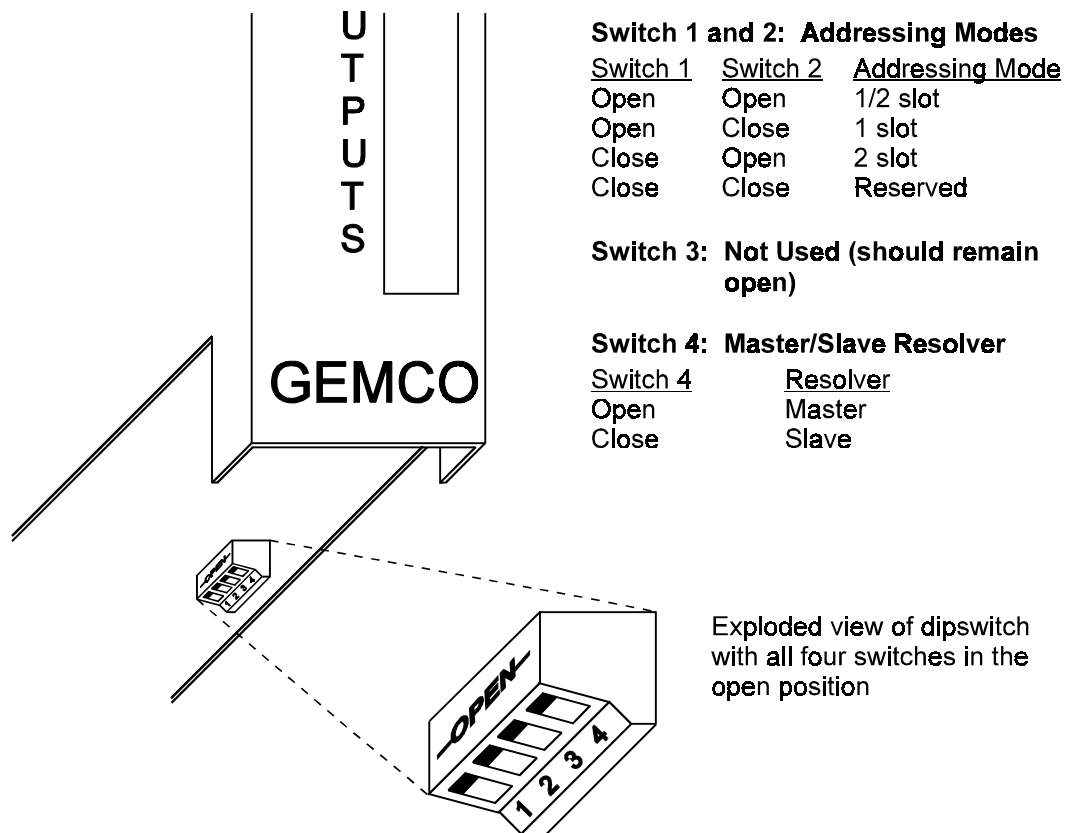

**Figure 3-1** PLS Dipswitch

**NOTE:** The address mode setting also affects the amount of data that can be transferred directly to and from the I/O image table. See Section 6.2: Configuration Group for more information.

Refer to Figure 3-2 while performing the following steps. If you are using I/O chassis keying, refer to Figure 3-2 for keying.

1. Turn off power to the system. This includes power to the rack as well as all power to the wiring leading to the 1771 I/O chassis.
2. Insert the module into the desired slot in the chassis.
3. Attach the 50-pin cable to the mating connector marked “INPUTS/OUTPUTS” on the PLS module. See Figure 3-2 for pinouts if you are using your own cable.
4. Attach the other end of the 50-pin cable to its mating half on the I/O module rack. Make sure the cable’s key aligns with the slot on the I/O module rack’s connector.
5. Remove the 6-pin mating connector from the PLS. This connector is for the resolver cable.
6. Attach the resolver’s wires to the terminals of the mating connector. Use the pinouts found on the PLS to connect each wire to its proper terminal. See Figure 3-3 if you are using your own cable.

The Gemco resolver cable has three pairs of twisted wires.

7. Connect cable shield to earth ground.
8. Attach the other end of the resolver cable by pushing and then screwing the cable’s connector onto the resolver.
9. Power up the system.

The Fault LED should light up at first and then turn off. If the Fault LED does not turn off, see Appendix A: Troubleshooting.

---

**NOTE:** When extensions to the factory supplied resolver cable are necessary, a junction box should be used to connect the wire leads and cable shields from one cable to the other. The junction box is used to isolate the splices of the connecting wires from outside electrical noises. Ground the cable shields at the controller case only.

---

---

**NOTE:** Verify the 1A fuse on the I/O rack is installed in the position closest to the ribbon cable connector.

---

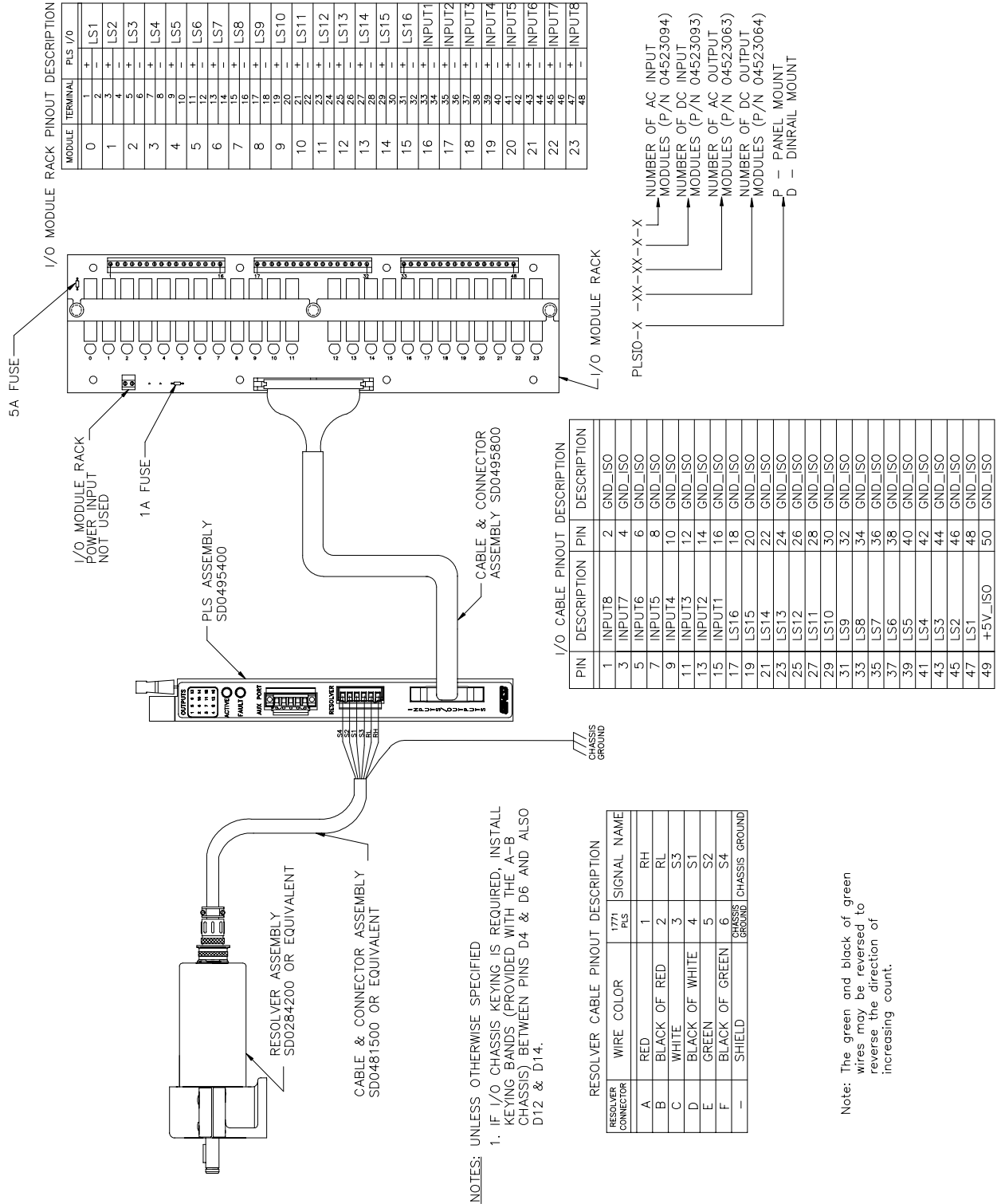

**NOTES:** UNLESS OTHERWISE SPECIFIED  
 1. IF I/O CHASSIS KEYING IS REQUIRED, INSTALL KEYING BANDS (PROVIDED WITH THE A-B CHASSIS) BETWEEN PINS D4 & D6 AND ALSO D12 & D14.

Note: The green and black of green wires may be reversed to reverse the direction of increasing count.

RESOLVER #	MFG.	R1	R2	R3
CR-1095-004-010	SINGER	N/A	1.5K	1.5K
U-2211134	TRANSICOIL	240. $\Omega$	-	-
11-BHW-40F/F473	CLIFTON	-	2K	2K
CR41093053	SINGER	-	2K	2K
CR4-1093-052-14	SINGER/KEARFOTT	-	-	-

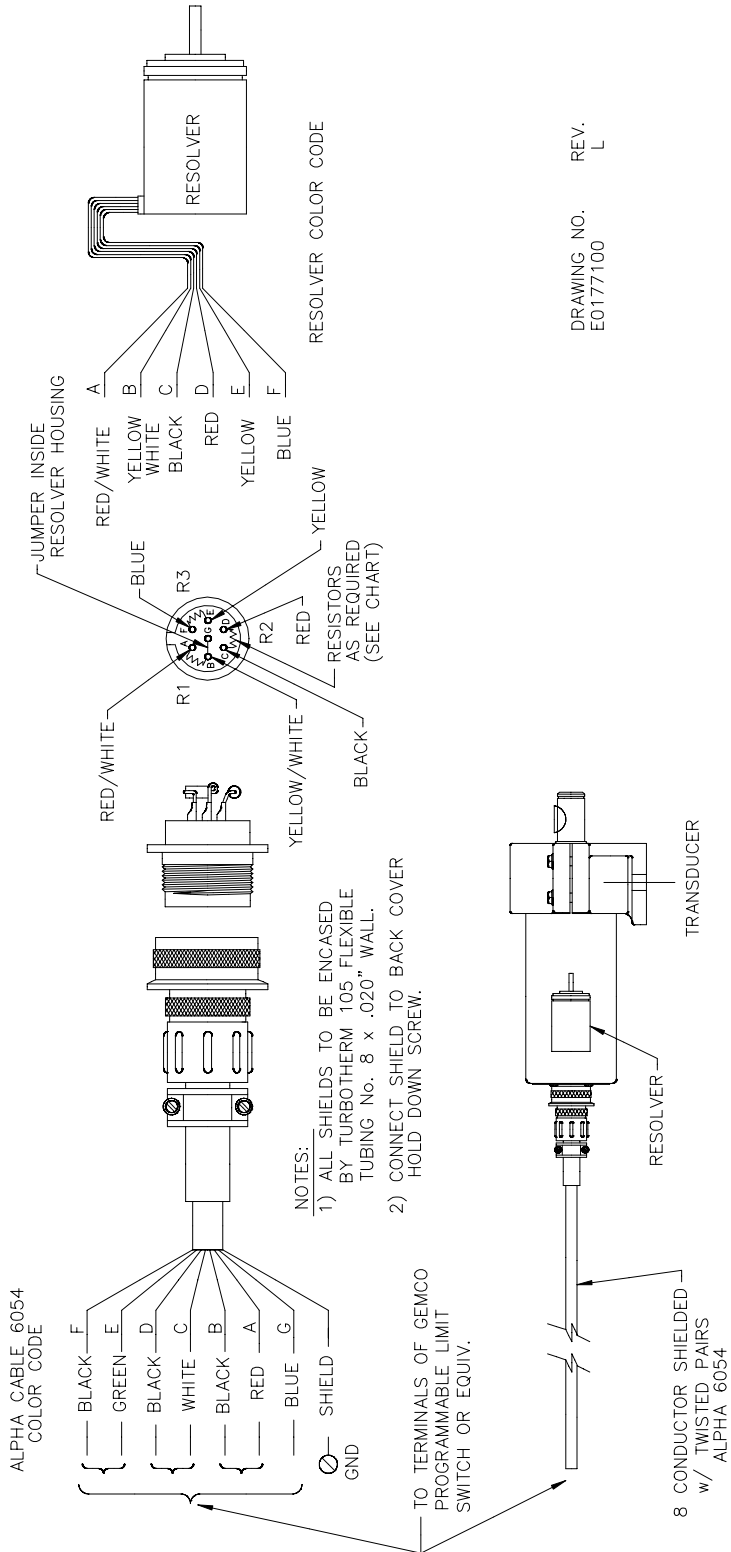
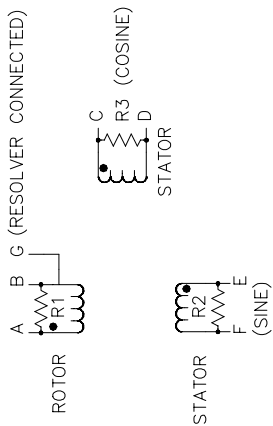

DRAWING NO. REV. L  
E0177100

# Chapter 4: Getting Started

This chapter discusses programming basics (Section 4.1: Things to Consider Before Programming), and provides a programming outline for the PLS (Section 4.2: Initial Setup). Keep in mind that the outline does not provide detailed descriptions of the PLS features or programming instructions. For this information, see Chapter 5: Overview of Features and Chapter 6: Programming Details. If you are not familiar with the PLS features and would like to learn more before programming, it is recommended that you first read Chapter 5. This chapter contains information on how the PLS works. However, if you want to program the PLS now, use the outline in Section 4.2 as a guide.

Another thing to consider before programming is how certain commands can erase data from the

## 4.1: Things to Consider Before Programming

Before you begin to program the PLS, there are some things you should consider. The first is that the PLS always maintains two copies of your program. The backup copy is held in nonvolatile memory, which means that it will not be lost even when the PLS is powered down. When you make changes to the PLS's setpoint and configuration data, you are changing the running program. See Figure 4-1. Once you are satisfied that your changes are correct, you should always save them by using the Save command (40). The Save command copies the running program into the backup copy. If you forget to save your changes, they will be lost if the PLS loses power. If you make changes to the running program and decide you do not want to keep those changes, you can undo them by using the Restore command (50). This command copies the backup copy back into the running program. All transfers are handled seamlessly from the running program to the nonvolatile memory and back again.

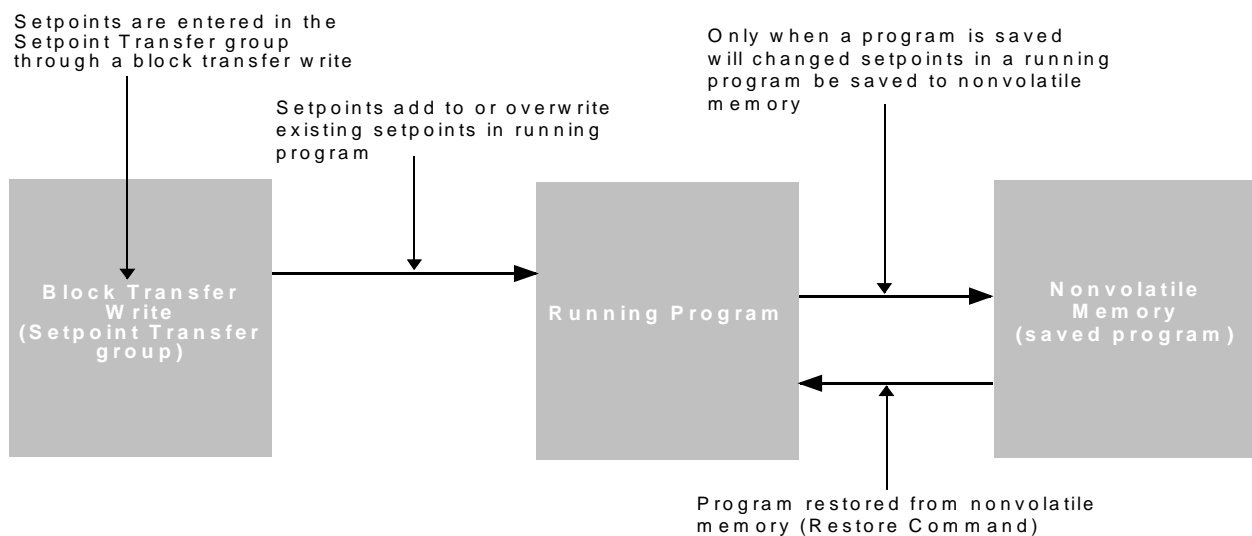

**Figure 4-1** Relationship Between Running Program and Saved Program



**NOTE:** You can restore a program from nonvolatile memory by using the Restore command (50). For instructions on how to use this command as well as others, see Section 6.8: Commands.

---

PLS's running program. For example, changing the resolver's scale factor will erase setpoint data saved in the running program. Because of this, it is recommended that you set the scale factor before you begin programming. For a list of the steps that should be taken when programming the PLS, see Section 4.2: Initial Setup.

## 4.2: Initial Setup

This section provides a sequence of steps that need to be taken in order to program the PLS properly. Keep in mind that this is only an outline and does not provide detailed explanations on how the PLS features work or detailed programming instructions. This information can be found in Chapter 5: Overview of Features and Chapter 6: Programming Details. If you are not familiar with the PLS features and would like to learn more before programming, read Chapter 5 before beginning this section. The following are the sequence of steps in which the PLS should be programmed:

1. Selection of Scale Factor (Configuration Group)
2. Motion Detect Output (Configuration Group)
3. Minimum Speed Disable (Configuration Group)
  
4. Synchronization with Machine (Command Group)
  
5. Programming Setpoints (Setpoint Transfer Group)
  
6. Linear Speed Offset (Linear Speed Offset Group)
  
7. Reset to Preset (Input Configuration Group)
8. Output Enabler (Input Configuration Group)
9. Remote Setpoint Tuning (Input Configuration Group)
10. Input Capturing (Input Configuration Group)

---

**NOTE:** Due to the interaction of certain programmed features and programming sequences, initial setup should be performed in the sequence noted. If a listed feature is not being used in your application, proceed to the next step. Programming is performed in block transfers. All data in a common group can be programmed in a single block transfer. You will note that the listed sequence groups data that appears in a common group.

---

**NOTE:** To reverse the resolver count direction from clockwise to counterclockwise, switch resolver's black of green wire with green wire.

---

## Step 0: System Initialization

System initialization establishes all default values in the memory. It is good standard practice to reinitialize any module being used for the first time in a new system. This will clear all unwanted data in the memory and will reestablish all factory default values preventing unwanted data from interfering with the operation of your new application program. This should only be performed one time per installation.

## Step 1: Selection of Scale Factor

The scale factor can be programmed to whatever engineering units you want, or are appropriate for your application. For example, one rotation of the resolver could represent one product moving through the machine. The length of the product could then be programmed as the scale factor and setpoints can then be programmed in length units that represent where they occur along the product. Valid scale factors can be from 2–65535. Setting the resolver's scale factor will erase any existing setpoint data. For this reason, programming the scale factor should be done before any other programming. For programming details, see Section 6.2: Configuration Group.

## Step 2: Motion Detect Output

Any one of the 32 limit switch output channels can be configured to operate as a motion detect output. This output will energize based upon reaching a programmed RPM value and will de-energize as RPM drops below the selected RPM value. Typical uses for this feature include latching in a machine operation when a desired operating speed is reached or for detecting a broken coupling or chain driving the resolver. For programming details, see sections 5.2: Motion Detect Output and 6.2: Configuration Group.

## Step 3: Minimum Speed Disable

This feature allows selected limit switch output channels to be automatically turned off if machine speed drops below a programmed RPM value. It can also be used to prevent output channels from turning on until a desired operating speed is reached. Typical uses include turning off glue guns or retracting actuators to a safe position under emergency stop conditions. For programming details, see Section 6.2: Configuration Group.

## Step 4: Synchronization with Machine (Home or Offset)

After programming the resolver's scale factor, you can then synchronize the resolver's position with the actual machine position. This is done through command 90 (Set Home). For command instructions, see Section 6.8: Commands.

## Step 5: Programming Setpoints (Standard and Stitching)

Setpoints are the on/off positions at which the limit switch outputs operate as the resolver turns through one rotation. All 32 output channels can be programmed for multiple on/off dwells over each rotation of the resolver by using standard setpoint programming sequences.

The stitching setpoint was created to reduce the tedious work of inputting evenly spaced on/off dwells over one rotation of the resolver. The following four steps show you how to program a stitching setpoint. These steps will greatly reduce the programming of dozens of on/off dwells:

1. Select pattern start position on product.
2. Select pattern stop position on product.
3. Select number of counts over which stitch stays on.
4. Select number of counts over which stitch stays off.

---

**NOTE:** A stitching pattern can also be used to develop an incremental output for use by an external control device like a variable frequency drive.

---

For details on programming standard and stitching setpoints, see sections 5.1: General Features and 6.5: Setpoint Transfer Group.

## Step 6: Linear Speed Offset

Linear speed offset automatically advances and/or retards limit switch outputs as machine speeds vary. This function is used to compensate for the mechanical lag in glue guns and actuators that must be precisely synchronized with the position of a product moving through a process. For additional information, see sections 5.3: Linear Speed Offset and 6.3: Linear Speed Offset Group.

## Step 7: Reset to Preset

This feature is used to synchronize groups of output channels to the product moving through a process, or to compensate for mechanical slippage or drift which may occur between the resolver and actual machine position. Any or all eight inputs can be tied to pre-selected groups of output channels. A preset value from 0 to the maximum scale factor value is then selected. Upon actuation of the input, all output channels tied to that input are reset to the preset value and begin firing their output pattern based upon continued movement from the reset point.

Most assembly or packaging applications use a sensor to detect the leading edge or registration mark on a product. This input resets a group of outputs to zero to perform a series of operations as the product continues through the process. All reset to preset inputs can be used simultaneously and will work independently to reset different groups of output channels. For programming details, see sections 5.5: Special Purpose Inputs and 6.4: Input Configuration group.

## Step 8: Output Enabler

Output enabler inputs are used to enable or disable selected groups of output channels based upon sensing a critical event prior to each rotation of the resolver. Typical uses of this feature include verification that a product is present at a glue station prior to allowing the glue guns to operate. Any or all inputs can be programmed to enable or disable selected groups of output channels based on sensing the enable input prior to the start of the output pattern. All output enabler inputs can be used simultaneously and will work independently to enable different groups of output channels. For programming details, see sections 5.5: Special Purpose Inputs and 6.4: Input Configuration Group.

## Step 9: Remote Setpoint Tuning

Any or all inputs can be used to advance or retard a pre-selected group of output channels from a remote location. Actuation of the advanced or retard input will move all setpoints on the selected output channels forward or backward by a programmable number. Operators can make count adjustments to the outputs while standing at the workstation. For programming details, See sections 5.5: Special Purpose Inputs and 6.4: Input Configuration Group.

## Step 10: Input Capturing

The input capturing feature is used to detect the resolver position at which the eight (8) front panel inputs or two (2) I/O image table inputs occur. This feature can be helpful for fine tuning the location and timing of photoelectric or proximity sensors that provide inputs to the PLS module. It can also be used to verify the presence or completion of critical assembly processes for quality control purposes. For example, if bottles are being capped, one of the inputs can be used to verify that each bottle cap is present as they pass a sensing device. If not detected, the PLS will warn the PLC's application program that a bottle was not capped. For programming details, see sections 5.6: Input Capture and 6.4: Input Configuration Group.

## Advance Application Features

- Specific pieces of data can be transferred via block transfer reads or programmed to be placed directly in the PLC I/O image table. Data transferred directly to the I/O image table will be updated every I/O scan of the PLC. See Section 6.2: Configuration Group for details.
- There are two I/O image table inputs that can be used for the same functionality as the eight (8) front panel inputs. This allows the special input features described in Section 5.5: Special Purpose Inputs, to be actuated by internal PLC logic instead of an external input. See Section 6.4: Input Configuration Group for details.

- The five (5) microsecond update time of the 16 ultra high-speed limit switch outputs will allow the use of these output channels as incremental outputs of resolver velocity or position. The extended setpoint programming sequence (described in sections 5.1: General Features and 6.5: Setpoint Transfer Group) can be used to start your incremental pulse train at position zero, and end at your maximum scale factor number with the desired number of pulses per revolution being programmed by mathematically calculating the appropriate on-count and off-count duration.
  
- The eight (8) front panel inputs can be used as general purpose inputs for your PLC application program. The state of these inputs can be programmed to appear in the I/O input image table of the PLC. (The use of these unused input channels for general purpose use in your application program can eliminate the need for additional discrete input cards in your I/O chassis.)

# Chapter 5: Overview of Features

This chapter describes the Series 1771 PLS features. By reading this chapter, you will understand how output channels, for example, are affected by linear speed offset or reset to preset inputs. This chapter discusses the PLS's features in the following order:

- Limit Switch Setpoints
- Motion Detect Output
- Linear Speed Offset
- Minimum Speed Disable
- Special Purpose Inputs
- Input Capture

## 5.1: Limit Switch Setpoints

This section describes the programming of limit switch outputs which are on/off relay outputs based upon the resolver position. A dwell is the number of scale factor counts between where the output channel is programmed to turn on and its programmed off position. All output channels can be programmed for multiple on/off dwells over one rotation of the resolver. The following two ways can be used to program setpoints:

- Standard Setpoints
- Extended Setpoints

### Standard Setpoints

A standard setpoint programming sequence is used to program an output channel to energize and de-energize over a dwell, or multiple dwells where their spacing and duration are randomly positioned over one resolver rotation. Programming a setpoint is based on the system's programmed scale factor. For example, assume the resolver is set for a 360° scale factor. If you programmed output channel 1 to energize at 180° and de-energize at 270°, output channel 1 would energize as shown in Figure 5-1. The shaded area represents the area where the output channel is energized.

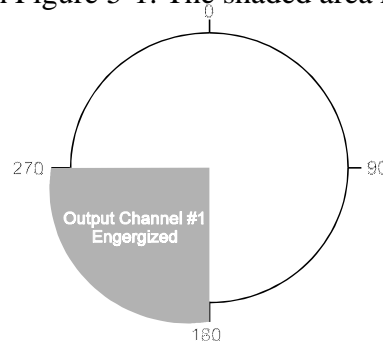

**Figure 5-1** Programmed output Channel based on a 360° Scale Factor

You can also program multiple on/off dwells on any output channel. As a result, an output channel can become energized and de-energized more than once over one rotation of the resolver. Figure 5-2 illustrates an output channel becoming energized from 20–80°, 100–180°, and 200–270°.

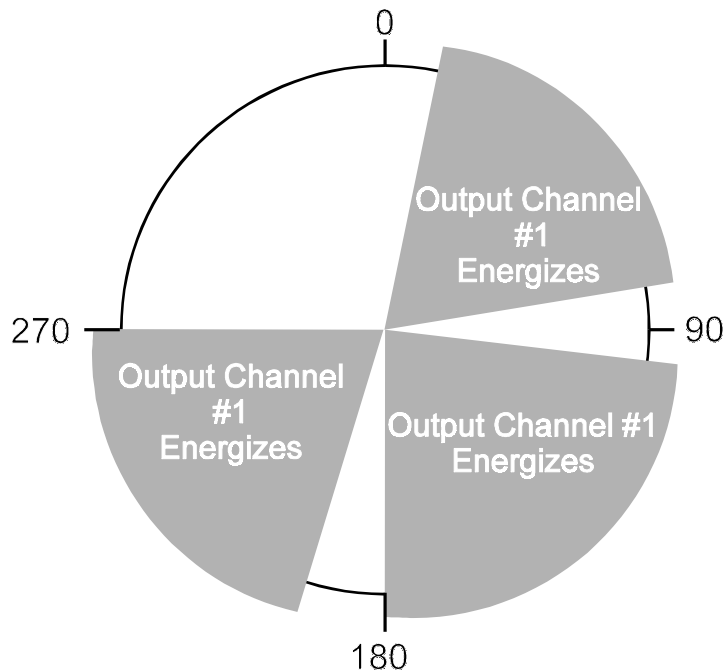

**Figure 5-2** Multiple On/Off Dwells for a Single Output Channel

## Extended Setpoints

Extended setpoints require additional data. The Series 1771 supports one extended setpoint called a stitching setpoint. A stitching setpoint is used to program an output channel to energize and de-energize numerous times within a programmed starting and stopping position. Unlike an output channel programmed with randomly spaced multiple on/off dwells, output channels programmed with stitching setpoints repeat the same on/off dwell a series of times like a sewing machine making a series of stitches in fabric. This function can be used to drive a glue gun to apply dozens of small drops of glue spaced evenly across the length of a product. Using stitching setpoints reduces programming to five easy steps—instead of programming numerous on/off positions. Figure 5-3 illustrates stitching patterns programmed on an output channel.

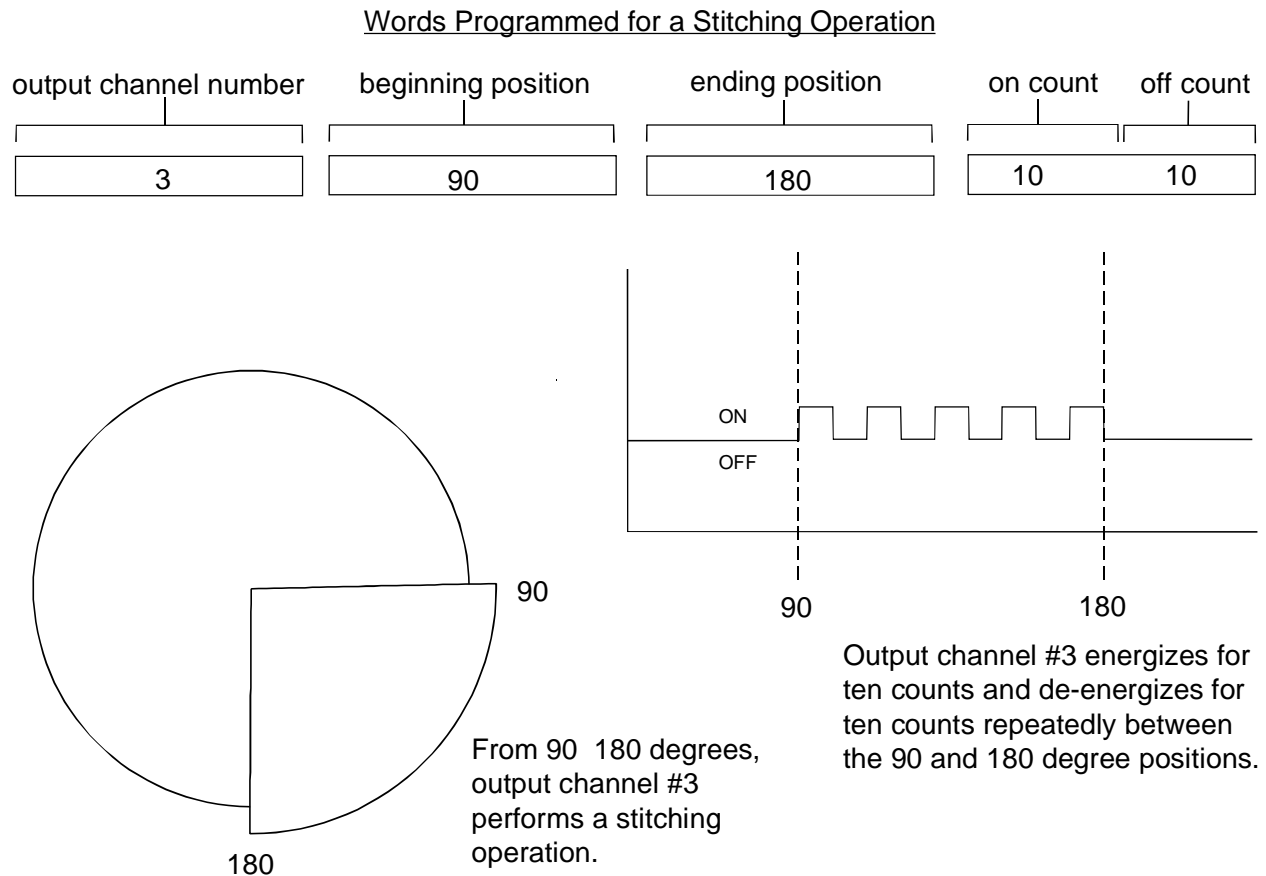

**Figure 5-3** Positions for a Stitching Operation

This same stitching pattern sequence can be used to program an incremental output from one of the limit switch output channels. This incremental output can be fed to an external drive or controller. To program, set your beginning position at zero, your ending position at your maximum scale factor count, and calculate the appropriate on-count and off-count duration to provide the desired number of pulses per revolution.

Setpoints are programmed using the Setpoint Transfer group described in Section 6.5: Setpoint Transfer Group. A series of setpoints are programmed by specifying the group identifier number followed by the appropriate setpoint command, and finally, the number of standard setpoints that are about to be sent followed by the number of extended setpoints. A series of setpoints are then specified using a programming sequence that identifies the output channel number followed by one on and one off position. Multiple setpoints on any output channel require the re-specification of the output channel number for each additional on/off setpoint. All standard setpoints must be completed prior to programming extended setpoints.



## 5.2: Motion Detect Output

A motion detect output provides an output whenever the resolver RPM reaches a pre-selected value. Word 14 of the Configuration group is used to select one of the 32 output channels to operate as a motion detect output. If one of the output channels from 1–16 is selected, the output channel will be one of the ultra high-speed outputs accessed through the front panel connector. If one of the output channels from 17–32 is selected, the motion detect output will appear in the I/O image table. However, the later will only work if the I/O image input selection is programmed properly. (For more information, see I/O Image Input Selection 1 and 2 words in Section 6.2: Configuration.) Word 15 of the Configuration group is used to specify the RPM value at which this output turns on. There is no inherent hysteresis around the programmed RPM value. This output will turn on at the specified RPM value and turn off at one RPM below the value.

## 5.3 Linear Speed Offset

Linear speed offset allows output channels 1–16 to be individually selected and programmed to advance and retard depending on the speed of the resolver. This function is used to compensate for the mechanical lag in glue guns and actuators that must be precisely synchronized with the position of a product moving through a process. The values assigned to the words in the linear speed offset group establish the rate of change (counts per RPM change) for the specified outputs. A different rate of change can be programmed for the leading edge (on offset) and the trailing edge (off offset) of the on/off dwells on the selected output channel.

For example, let's say we programmed the LS 1 RPM word with a value of 100; the LS On Offset word with a value of 20; and the LS Off Offset word with a value of 10 (See Section 6.3: Linear Speed Offset for details). This will advance the leading edge of all setpoints on output channel 1 by 20 counts and their trailing edge by 10 counts for every 100 RPM increase in resolver velocity. This rate of advance is applied linearly as speed increases from zero and will continue as speeds increase beyond 100 RPM. In other words, if the resolver increased to 50 RPM, the setpoint's leading edge would advance by 10 counts and its trailing edge would advance by 5 counts. This is illustrated in Figure 5-4.

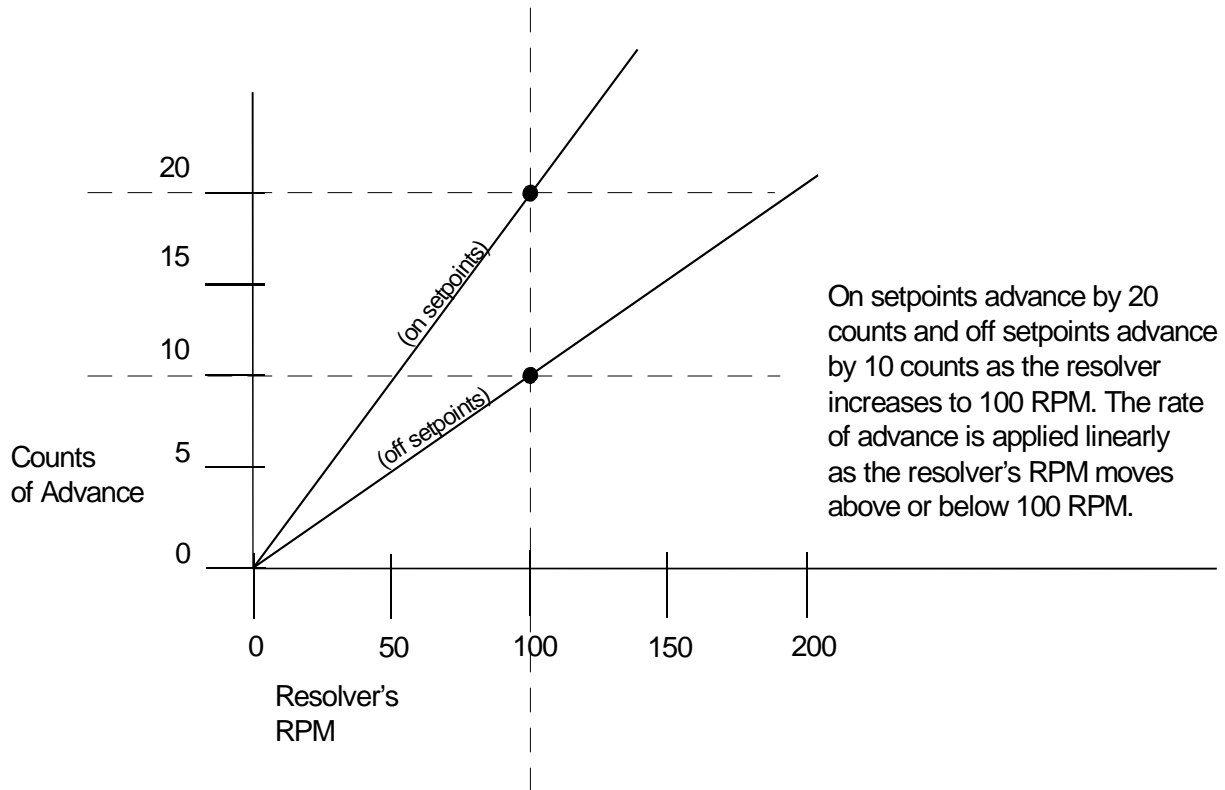

**Figure 5-4** Linear Speed Offset

## 5.4: Minimum Speed Disable

Minimum speed disable functions allow selected output channels to become disabled upon machine RPM dropping below a programmed value.

### Disabling Output Channels 1–16

Output Channels 1–16 can be programmed to become disabled if machine RPM drops below a programmed value. This is done through the Minimum RPM Disable word (Configuration group) and the Set Speed Channels Word (configuration group). You can select any one or any combination of the 16 ultra high-speed outputs for this function. Selecting the output channels is done through the Set Speed Channels Word. The minimum RPM is programmed through the Minimum RPM Disable word. If at any time during machine operation the resolver's speed drops below the programmed minimum RPM, the selected output channels will become disabled.

The minimum RPM value and the set speed channel words are programmed using the Configuration group as described in Section 6.2: Configuration Group

## 5.5: Special Purpose Inputs

There are eight (8) inputs accessed through the front panel connector and two (2) I/O image table inputs controlled directly by your application program. The two I/O image table inputs correspond to bits 9 and 10 in the Mode Control word (Configuration group).

Any or all of these inputs can be configured to be used as reset to preset, output enabler, or remote setpoint tuning inputs. You should also note that regardless of how these inputs are configured, the resolver position at which input transitions occur will be captured by the Input Capture words and Input Transition Map word (Status group).

This section discusses configuring these inputs in the following order. See Section 5.6: Input Capture Features for details on using the input capture features.

- Reset to Preset
- Output Enabler
- Remote Setpoint Tuning

### Reset to Preset

Reset to preset inputs allow selected output channels to be reset to a programmed position value upon seeing an input from a remote sensor. This type of input is typically used in applications where parts are randomly spaced as they enter a workstation. Upon seeing the leading edge of the part enter the workstation, output channels can be reset to a preset position value. The output channels will then begin to operate based upon their on/off setpoints *relative* to a preset value which has been synchronized with the leading edge of the product. Because the reset to preset input resets the output channels' positions when it senses a part entering the workstation, it doesn't matter at what position on the resolver a part enters the workstation. In Figure 5-5, output channels 5 and 7 are linked to input 6. These output channels have been programmed to have a reset to preset value of zero. During machine operation, input 6 becomes energized at machine position 180. Because output channels 5 and 7 are linked to input 6, they reset to

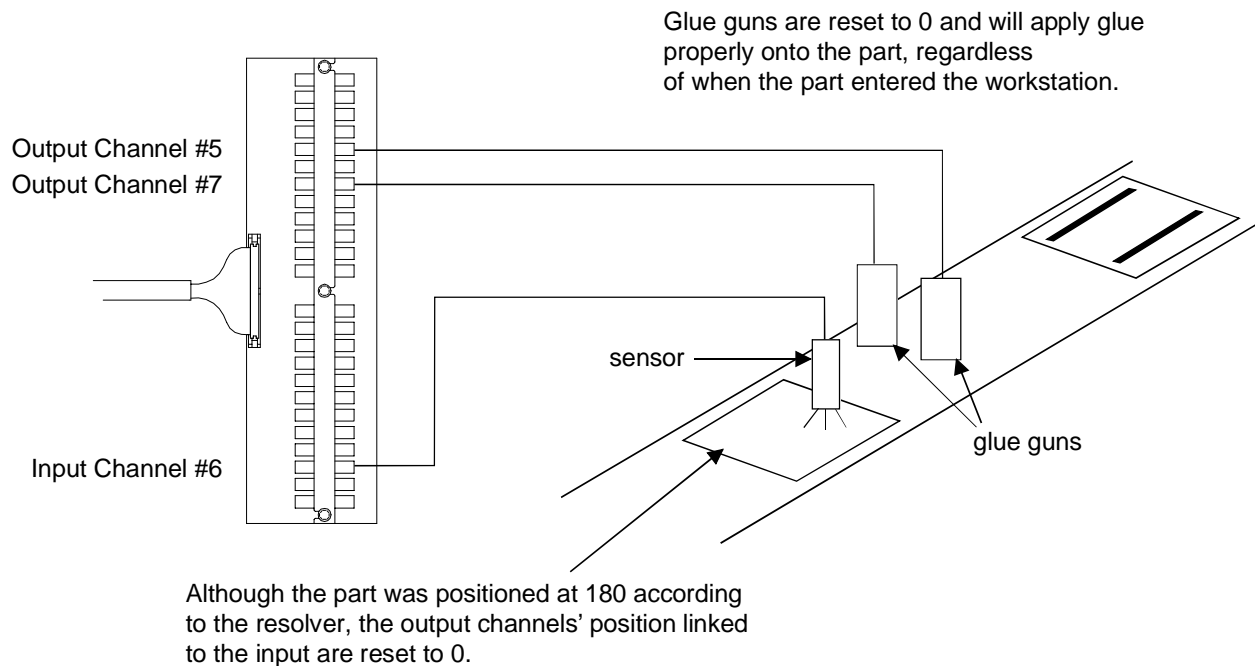

position 0. In this way, the outputs energize at the proper position, according to their on/off setpoints relative to the position at which the input was energized. For information on how to link output channels to reset to preset inputs and programming of the reset value, see Section 6.4: Input Configuration.

**Figure 5-5** Output Channels Reset to Zero When Part is Sensed

There are two modes of operation for the reset to preset inputs. They are as follows:

### Standard Mode

The selected output channels reset to the preset position value upon seeing the input. The setpoints will operate over their programmed values continuously. As the resolver continues to rotate through zero, the output channels will continue to track the reset resolver position and the setpoints will operate at their programmed values. For instructions on how to program the inputs to operate in the standard mode, see Section 6.4: Input Configuration Group.

### Single-Shot Mode

The selected output channels reset to the preset position value upon seeing the input. The setpoints will operate over their programmed values through one rotation of the resolver. After one complete revolution, the output channels will remain de-energized until the next reset input is sensed. For instructions on how to program the

inputs to operate in the single-shot mode, see Section 6.4: Input Configuration Group.

## Output Enabler

Output enabler inputs are used to enable or disable groups of selected output channels based upon sensing a critical event prior to or during each rotation of the resolver. Typical uses include verification that a product is present at a glue station prior to allowing the glue guns to operate. They are as follows:

### One-Shot Mode

In one-shot mode, you program a window in which the input must change state in order to allow their linked output channels to operate over the current rotation of the resolver. If the input does not change state within the programmed window, the linked outputs will not operate. In Figure 5-6, the output enabler input (input channel 3) is linked to output channels 5 and 7. When the input senses the part, the glue guns (controlled by the output channels) are enabled, and will apply glue onto the part according to their on/off setpoints. However, if a part is not sensed within the programmed window, the linked output channels will be disabled through

Chart represents the input channel's window of detection (35 to 45) and the input's actual transition. Notice that the input detection window closes before the output channels' first on/off dwell.

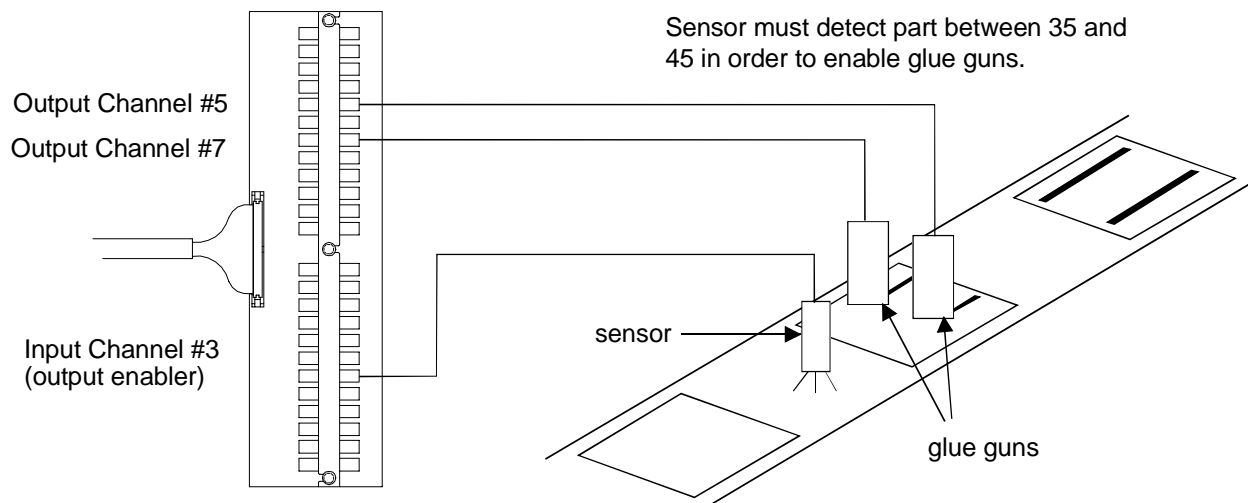
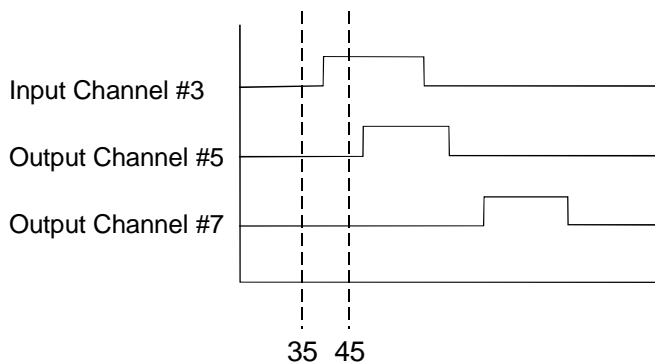

**Figure 5-6** Output Enabler Input (One-Shot Mode) Enables Output Channels

that rotation of the resolver. For more information on linking an output channel to one of the output enabler inputs, see Section 6.4: Input Configuration Group.

**NOTE:** In order for an output enabler input (one-shot mode) to enable output channels, the input must transition sometime between the resolver's zero position and the first on setpoint position of the output channel that is linked to the input. The output enabler input can remain energized for any duration—as long as it de-energizes before it is suppose to transition again within its window.

**Level Mode** Level mode will operate like a simple AND input. The output pattern will only operate as long as the output enabler input is energized. Therefore, the product presence sensor must provide an input during the full duration of the limit switch output pattern. If the input goes low, the output channels will be de-energized.

## Remote Setpoint Tuning (Phasing)

Remote setpoint tuning inputs can be used to advance or retard a pre-selected group of output channels from a remote location. (See Figure 5-7.) Actuation of the advance input will move all setpoints on the selected output channels forward in predefined (programmable) increments. Actuation of the retard input moves these same setpoints backward in predefined (programmable) increments. Operators can watch these changes and make small adjustments to the outputs while standing at the workstation where the actuators are located. For more information on linking output channels to remote setpoint tuning inputs, see Section 6.4: Input Configuration Group.

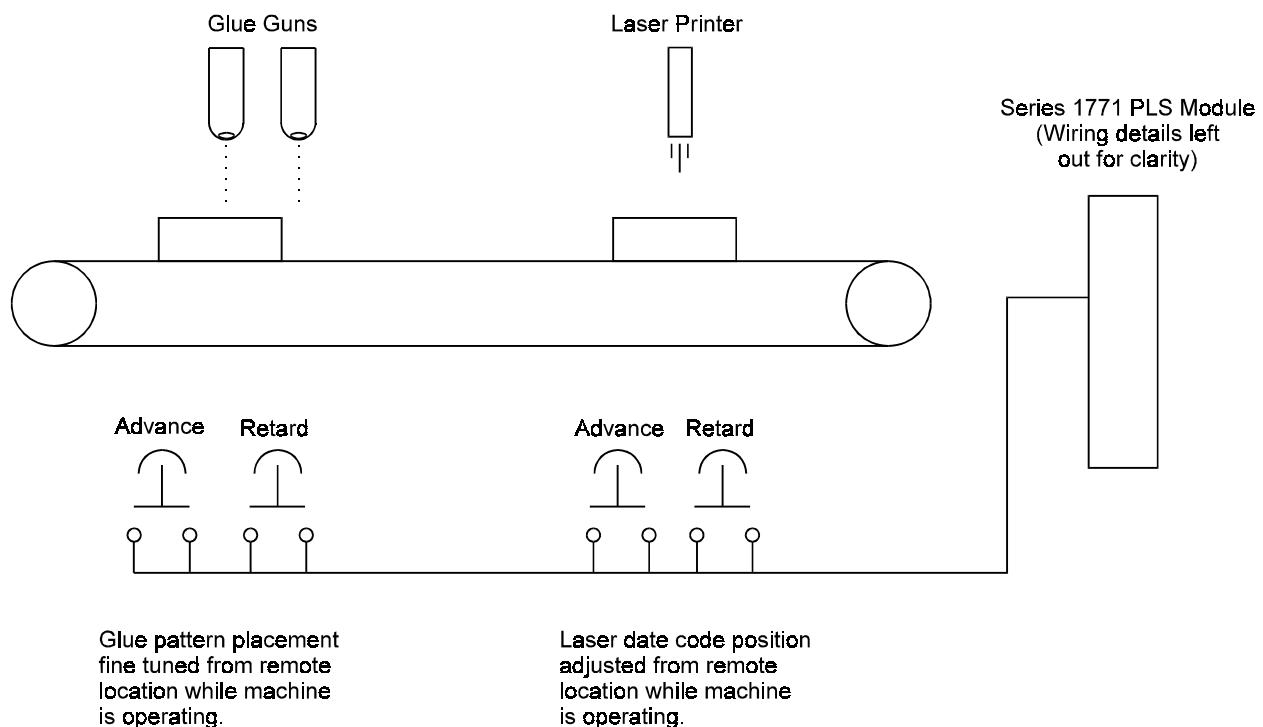

**Figure 5-7** Remote Setpoint Tuning

This feature can also be used to automatically fine tune output patterns for proper placement. Any dynamic sensing circuit that monitors the final placement of an assembly process can be used to automatically actuate these inputs. The actuated inputs can be either the front panel accessed inputs or the two I/O image table inputs.

The input capture capabilities covered in Section 5.6: Input Capture could be used to monitor the position at which an assembly event occurs. This data can then be used to advance or retard the outputs through logic in your application program by pulsing the remote setpoint tuning inputs.

## 5.6: Input Capture

Words 14–33 of the Status group automatically capture resolver positions where the eight hardware and two I/O image table inputs transition. You will note that for each input there is a word that will capture the position for an up transition and another word for the position for a down transition. This position data will be captured for all inputs regardless of the function that they have been configured for, except when a specific input has not been enabled for any function. See Figure 5-8.

This feature will allow you to verify the resolver position at which remote setpoint tuning, output enabler, or reset to preset inputs are seen by the PLS module and could be helpful in fine tuning the placement of sensors or the timing of inputs. However, the more common use for this feature is the gathering of quality control data during an assembly process. Photoelectric or similar sensors can be used to verify that a product feature has been installed on a product at the correct position. To program one or more of the inputs to act in this way, enter the value 32 in the Input Type words (Input Configuration group) to configure the input for use in the input warning map mode. Parameter words are then used to establish the on/off window in which the input must occur to indicate a properly positioned event. If an event is not seen within the established window, a bit is set in the Input Warning Map word (Status group). This bit can be used by your application program to trigger rejection of the incorrectly assembled product. The Input Warning Map bit will be cleared the next time the event is detected within the window. For more information, see Section 6.4: Input Configuration Group.

In both scenarios, Input Channel #5 is programmed as an Input Warning Map (32). The on/off positions are programmed to create a detection window between 90° and 270° with a scale factor of 360°. Parts should be sensed inside this window. *Scenario 1* shows what happens when a part is detected within the detection window, and *Scenario 2* shows what happens when a part is *not* detected within the detection window.

**Scenario 1: Part Detected Within Programmed Window.**

**Scenario 2: Part Not Detected Within Programmed Window.**

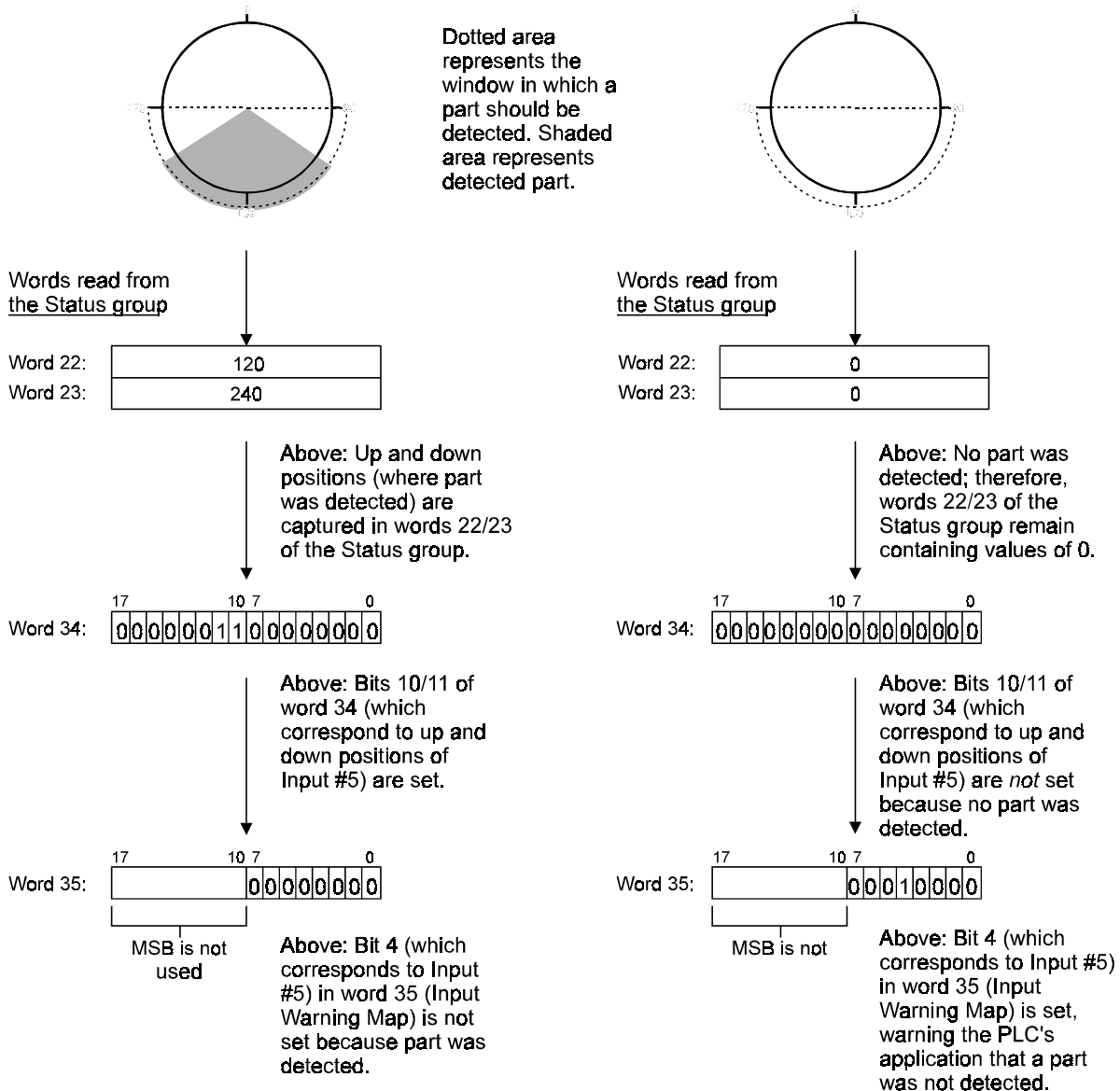

**Figure 5-8** Two Scenarios Demonstrating the Input Capture Feature



# Chapter 6: Programming Details

This chapter describes the data structure of the Series 1771 PLS. This data is comprised of words categorized into seven groups. A *group identifier number* is assigned to each group. The group identifier number must be entered into the first word of a group before a block transfer can occur. This number informs the PLS that the data in the group follows the rules of that particular group. This chapter provides maps of the words for each group and descriptions of how each word in each group works. This chapter does not provide theory on how the PLS's features are used in applications. For descriptions of these features, see Chapter 5: Overview of Features. The following is a list of the groups and their group identifier numbers:

- Status group (#1)
- Configuration group (#2)
- Linear Speed Offset group (#3)
- Input Configuration group (#4)
- Setpoint Transfer group (#5)
- Command group (#6)
- Fault History group (#7)

---

**NOTE:** All bits are defined in octal (0–7, 10–17).

---

## 6.1: Status Group

The Status group consists of 36 words (0–35). During run time, the PLS updates these words every 500 microseconds. By reading from these words, the host application program is able to keep track of the PLS's operating status; the resolver's position and RPM; the current state of output channels 1–32 and input channels 1–10; as well as other necessary aspects for the host application program to control the PLS program properly. The program should only read from these words. The group identifier number is 1. The following is a map of the words contained in the Status group:

Word	Bit Number	Name (read only)
0		Group Identifier (#1)
1		Hardware Version
2		Firmware Version
3		Status Word
	0	Fault
	1	Warning
	2	Valid File
	3–5	(reserved)
	6	Processor Busy
	7	Running
	10–17	(reserved)
4		Fault Condition
5		Warning Condition
6		Current File Number
7		Current File CRC
8		Current Position
9		RPM
10		Input State
11		Remote Setpoint Tune
12		PLS Outputs (LS32–LS17)
13		PLS Outputs (LS16–LS1)
14		Input 1 Up Capture
15		Input 1 Down Capture
16		Input 2 Up Capture
17		Input 2 Down Capture
18		Input 3 Up Capture
19		Input 3 Down Capture
20		Input 4 Up Capture
21		Input 4 Down Capture
22		Input 5 Up Capture
23		Input 5 Down Capture
24		Input 6 Up Capture
25		Input 6 Down Capture
26		Input 7 Up Capture
27		Input 7 Down Capture
28		Input 8 Up Capture
29		Input 8 Down Capture
30		Input 9 Up Capture
31		Input 9 Down Capture
32		Input 10 Up Capture
33		Input 10 Down Capture
34		Input Transition Map
35		Input Warning Map

**Chart 6-1** Status Group

## Hardware Version (word 1)

This word contains the major and minor revision levels of the PLS hardware. These revision levels are divided into eight-bit numbers with the major level being the most significant.

## Firmware Version (word 2)

This word contains the major and minor revision levels of the PLS firmware. These revision levels are divided into eight-bit numbers with the major level being the most significant.

## Status (word 3)

This word indicates the PLS's current operating status. This is accomplished through five of the word's 16 bits. The PLS sets one of these bits when a condition occurs during machine operation which the bit defines. The following are definitions of the five bits:

<b>Fault (bit 0)</b>	This bit is set whenever the PLS detects an error which prevents output channels 1–32 from operating. The cause of a fault error usually is a result of the resolver failing to operate properly. It can also indicate an error with the PLS's internal hardware. The exact cause can be determined by examining the Fault Condition word (4).
<b>Warning (bit 1)</b>	This bit is set whenever the PLS detects an error which does <i>not</i> prevent output channels 1–32 from operating. This type of error is less severe than one which causes the Fault bit to be set. The cause usually is a result of an invalid parameter being written to one of the words in a block transfer write. The exact cause can be determined by reading the Warning Condition word (5).
<b>Valid File (bit 2)</b>	This bit is set when a valid program is loaded into the PLS's running program. This is <i>not</i> an indicator that a program has been saved to the PLS's nonvolatile memory.
<b>(bits 3–5)</b>	(reserved)
<b>Processor Busy (bit 6)</b>	This bit is set whenever the Series 1771 is processing data sent through a block transfer write. When this bit is set, the PLC should not send another block transfer write. This is to prevent commands from being overwritten before they have been completely processed.
<b>Running (bit 7)</b>	This bit is set whenever the PLS is running a program.
<b>(bits 10–17)</b>	(reserved)

## Fault Condition (word 4)

This word indicates the type of fault error that occurred which caused the Fault bit (0) in the Status word (3) to be set. If this word returns a total value of 2, no setpoint file exists. If this word returns a value of 512, this indicates that no setpoints were programmed when trying to put the PLS in run mode. However, the cause of a fault error usually is a result of the resolver failing to operate properly or an error with the PLS's internal hardware. When bit 10 is set, this indicates that a resolver error has occurred. The exact cause can be determined by examining the Fault Condition's error code. The actual error will be mapped in bits 0–3, resulting in a total decimal number from 257–271 when combined with bit 10 being set. The Fault Condition will hold the error code until the PLS receives another block transfer write. Chart 6-2 contains possible error codes:

Fault Condition Code	Bits Set	Explanation	Solution
2	N/A	No setpoint file exists.	Create a setpoint file.
257–271	bit 0	One of the resolver's stator coils may be open. The analog-to-digital circuitry may be damaged.	Refer to Appendix A: Troubleshooting.
	bit 1	One of the resolver's stator coils may be open. The analog-to-digital circuitry may be damaged.	Refer to Appendix A: Troubleshooting.
	bit 2	The resolver's primary coil may be shorted.	Refer to Appendix A: Troubleshooting.
	bit 3	The resolver's primary coil may be open.	Refer to Appendix A: Troubleshooting.
512	N/A	No setpoints were programmed prior to setting the PLS Run Enable bit (Configuration group).	Setpoints must be programmed when trying to put the PLS in run mode.

**Chart 6-2** Fault Condition Error Codes

## Warning Condition (word 5)

This word indicates the type of error that occurred which caused the Warning bit (1) in the Status word (3) to be set. The cause of a warning error usually is a result of an invalid parameter being written to one of the words in a block transfer write. The exact cause can be determined by examining the Warning Condition's error code. The Warning Condition will hold the error code until the PLS receives another block transfer write. Chart 6-3 contains possible error codes with explanations and solutions:

Warning Condition Code	Explanation	Solution
2	There are no setpoints programmed.	The Initialize command was sent to the PLS prior to run time or the scale factor was changed. Both acts erase all existing setpoints. Recreate a setpoint file.
3	The PLS ran out of RAM while trying to add setpoints.	Contact Gemco.
100	An invalid format, wrong channel number, or invalid on/off positions were written in a setpoint.	Check setpoints used in program for incorrect channel numbers, on/off positions, or improper format use. Refer to Section 6.5: Setpoint Transfer group for further assistance.
101	One or more invalid parameters were found in one or more of the Command Parameter words.	Write a valid parameter or parameters to the Command Parameter words with the command you are sending. Refer to Section 6.8: Commands for further assistance.
102	A command was sent to change or delete a setpoint that does not exist.	Check for wrong channel number or on/off positions in setpoint(s) you are trying to change or delete.
103	The Add command was sent to add a setpoint that already exists.	Check your setpoint file for redundant setpoints.
104	The scale factor in the Configuration Group is invalid.	Write a scale factor that is within the valid range. Refer to Section 6.2: Configuration Group to determine the scale factor's range.
105	An invalid command number was written to the Command word.	Write the correct Command number to the Command word. Refer to Section 6.8: Commands for further assistance.

Warning Condition Code	Explanation	Solution
106	A group identifier number received in a block transfer write is invalid, or the read block group identifier number in the Configuration group is invalid.	Check for an illegal group identifier number as well as for a wrong group identifier number placed in the Block Transfer Read Group Identifier word (Configuration group).
107	The data size of a block transfer does not match the size of the group specified by the group identifier number.	Verify that the proper group identifier number was used in the block transfer and whether too much or too little data was used in the transfer.
108	The data that was requested to be assigned to the input image table is invalid.	Verify the validity of the data.
109	The data that was requested to be assigned to the output image table is invalid.	Verify the validity of the data.
110	The channel number sent in the Linear Speed Offset group is invalid.	Send the correct channel number.
111	The change setpoint command tried to change a setpoint from one channel to another channel.	Channel numbers must match.
112	The input type sent in the Input Configuration group is invalid.	Verify the input data type for all input channels.

**Chart 6-3** Warning Condition Error Codes

## Current File Number (word 6)

This word indicates the number of the program running on the PLS. This number is given to the program when the PLC application program saves a program to the PLS's nonvolatile memory. This number is the number passed in the Command Parameter 1 word of the Save command.

## Current File CRC (word 7)

This word is reserved for Cyclic Redundancy Checking (CRC-16) for the Configuration group and the program running on the PLS.

## Current Position (word 8)

This word indicates the resolver's current position. The position will always be a number that ranges from 0 to the scale factor. See Section 6.2: Configuration Group for scale factor ranges.

## RPM (word 9)

This word indicates the resolver's current Revolutions Per Minute (RPM). This value ranges from -1800 to 1800.

## Input State (word 10)

This word indicates the current state of the eight input channels. Each of the first eight bits (0–7) of this word corresponds to each of the eight inputs. For example, bit 0 corresponds to input 1, bit 1 corresponds to input 2, and so forth. When one of the eight inputs becomes energized, its corresponding bit in this register is set to 1. The active state of these inputs can be inverted by setting the first eight bits (0–7) in the Mode Control word (Configuration group).

## Remote Setpoint Tune (word 11)

This word indicates which ultra high-speed output channels have been assigned to remote setpoint tuning inputs. When output channels are assigned to these inputs, their corresponding bits in this word will be set to 1. See Figure 6-1 for an example.

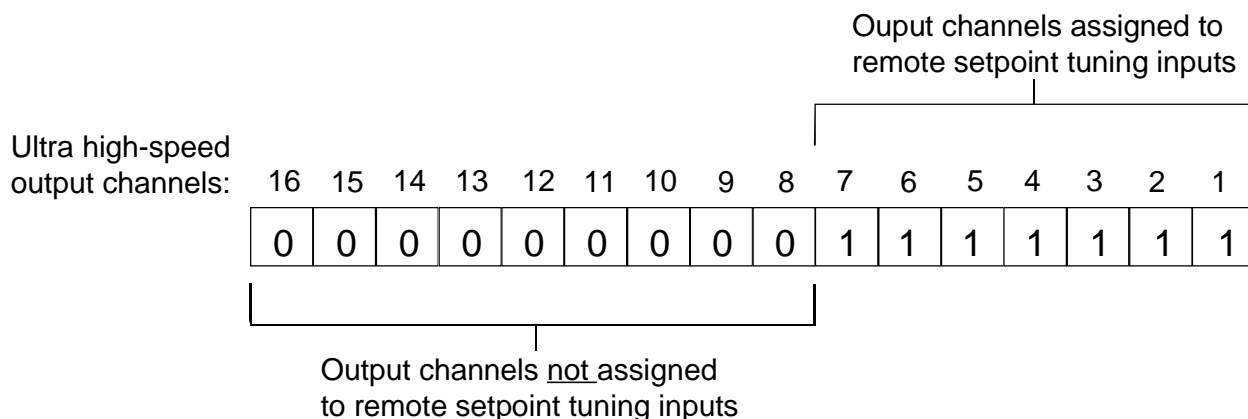

**Figure 6-1** Output Channels Assigned to Remote Setpoint Tuning Inputs

---

**NOTE:** For instructions on assigning output channels to the remote setpoint tuning inputs, see Section 6.4: Input Configuration Group.

---

## PLS Outputs LS32–LS17 (word 12)

This word indicates the current status of output channels 17–32. Each bit (0–17) corresponds to one high-speed output channel. For example, bit 0 corresponds to output channel 17, bit 1 corresponds to output channel 18, and so forth. When one of these output channels becomes energized, its corresponding bit is set to 1. The PLS updates these output channels every 500 microseconds.

---

## PLS Outputs LS16-LS1 (word 13)

This word indicates the current status of output channels 1–16. Each bit (0–17) corresponds to one ultra high-speed output channel. For example, bit 0 corresponds to output channel 1, bit 1 corresponds to output channel 2, and so forth. When one of these output channels becomes energized, its corresponding bit is set to 1. The PLS updates these output channels every five microseconds.

## Input Capture Words (14–33)

These words indicate the resolver positions where the 10 inputs become energized and de-energized. Word 14 corresponds to the position where input 1 becomes energized; word 15 corresponds to the position where input 1 becomes de-energized; word 16 corresponds to the position where input 2 becomes energized; word 17 corresponds to the position where input 2 becomes de-energized; and so forth. The input capture words are updated once per resolver revolution. For each revolution, the PLS internally records the resolver positions corresponding to input transitions. These are updated on either the rising edge, falling edge, or through zero. See Section 6.4: Input Configuration Group.

## Input Transition Map (word 34)

This word indicates whether the transitional positions recorded in the Input Capture words (14–29) occurred during the current turn of the resolver. When an input transition occurs, the input's corresponding bit in this word is set to 1. For example, when input 1 energizes, bit 0 is set; when input 1 de-energizes, bit 1 is set; when input 2 energizes, bit 2 is set; when input 2 de-energizes, bit 3 is set; and so forth. Bits set in this word are cleared (set to 0) by the PLS when the resolver passes the zero position. This is an important feature of this word. Because positions captured in the Input Capture words (14–33) are not cleared, but merely replaced with new captured positions, the Input Transition Map word can be used by the host application to determine if the captured positions are current.

---

**NOTE:** If an input transition occurs less than 500 microseconds after the resolver passes position 0, the Input Transition Map word may not indicate the input transition.

---

## Input Warning Map (word 35)

This word is used to warn the PLC application program when an input is not detected between a programmed on and off window. If an input is not detected within the window, the corresponding bits in this word will be set. The bit set will only be cleared when the input detects another transition. The eight bits correspond to the eight inputs when configured for input warning map operation. Bit 0 corresponds to input 1; bit 1 corresponds to input 2; and so forth. Bits 10–17 are ignored. The window in which an input is supposed to energize within, is programmed using the Parameter words (Input Configuration group). For more information on programming an input warning map operation, see Section 6.4: Input Configuration Group.



## 6.2: Configuration Group

The Configuration group consists of 15 words (0–14). These words are used to change the parameters of an application program. The group identifier number is 2. The following is a map of the words contained in the Configuration group:

Word	Bit Number	Name (read/write)
0		Group Identifier (#2)
1		Mode Control
	0	Channel 0 Input Invert
	1	Channel 1 Input Invert
	2	Channel 2 Input Invert
	3	Channel 3 Input Invert
	4	Channel 4 Input Invert
	5	Channel 5 Input Invert
	6	Channel 6 Input Invert
	7	Channel 7 Input Invert
	10	Input 9
	11	Input 10
	(12–16)	(reserved)
	17	PLS Run Enable
2		Force On (LS32-LS17)
3		Force On (LS16-LS1)
4		Force Off (LS32-LS17)
5		Force Off (LS16-LS1)
6		(BTR) Group Identifier
7		I/O Image Input Selection 1
8		I/O Image Input Selection 2
9		I/O Image Output Selection 1
10		I/O Image Output Selection 2
11		Scale Factor
12		Minimum RPM Disable
13		Set Speed Channels
14		Motion Detect Channel Number
15		Motion Detect RPM Minimum

**Chart 6-4** Configuration Group

### Mode Control (word 1)

This word contains bits which control the PLS's operating mode. The following are descriptions of these bits:

**Input Invert (bits 0–7)**

The eight inputs on the PLS faceplate are used with the input relays on the I/O module rack. A high input to an input relay activates the input on the PLS module faceplate. To invert this input, set the input channel's respective bit to 1. Bits 0–7 correspond in the same order to inputs 1–8. For example, bit 0 corresponds to input 1 and bit 7 corresponds to input 8.

**Input 9 (bit 10)**

This bit is used as an input from the I/O image table. It can act in the same way as the input relays on the I/O module rack (output enabler, reset to preset, input capture, and remote setpoint tuning) but comes through the I/O image table.

**Input 10 (bit 11)**

This bit is used as an input from the I/O image table. It can act in the same way as the input relays on the I/O module rack (output enabler, reset to preset, input capture, and remote setpoint tuning) but comes through the I/O image table.

**PLS Run Enable (bit 17)**

This bit is used to put the PLS in run mode. By default, this bit is initialized to 0 when the PLS is powered up. In order to put the PLS in run mode, set this bit to 1. When an error occurs during run time, the PLS will not begin to run again until the error is cleared.

**Force On LS32–LS17 (word 2)**

This word is used to force output channels 17–32 to energize. Each bit in this word corresponds to one of the high-speed output channels; bit 0 corresponds to output channel 17, whereas, bit 17 corresponds to output channel 32. Setting a bit to 1 will force the bit's corresponding output channel to energize. By default, these bits are initialized to 0 when the PLS is powered up.

**Force On LS16–LS1 (word 3)**

This word is used to force output channels 1–16 to energize. Each bit in this word corresponds to one of the ultra high-speed output channels; bit 0 corresponds to output channel 1, whereas, bit 17 corresponds to output channel 16. Setting a bit to 1 will force the bit's corresponding output channel to energize. By default, these bits are initialized to 0 when the PLS is powered up.

## Force Off LS32–LS17 (word 4)

This word is used to force output channels 17–32 to de-energize. Each bit in this word corresponds to one of the high-speed output channels; bit 0 corresponds to output channel 17, whereas, bit 17 corresponds to output channel 32. Setting a bit to 1 will force the bit's corresponding output channel to de-energize. By default, these bits are initialized to 0 when the PLS is powered up.

## Force Off LS16–LS1 (word 5)

This word is used to force output channels 1–16 to de-energize. Each bit in this word corresponds to one of the ultra high-speed output channels; bit 0 corresponds to output channel 1, whereas, bit 17 corresponds to output channel 16. Setting a bit to 1 will force the bit's corresponding output channel to de-energize. By default, these bits are initialized to 0 when the PLS is powered up.

---

**NOTE:** If an output channel is forced on and off at the same time, the force off will override the force on. As a result, the output channel will remain de-energized.

---

## Block Transfer Read (BTR) Group Identifier (word 6)

This word is used to specify which group of data the PLS should return when a block transfer read is performed. By entering one of the group numbers here, the PLS will send over the group's data to the PLC on all subsequent BTRs. It is up to the user to create an application program which instructs the PLS on where to place the data once it is sent over.

## I/O Image Input Selection 1 and 2 (words 7 and 8)

These words are used to configure data which the PLS will place in the I/O input image table. The assignment of these words are shown in Figure 6-2:

**Figure 6-2** I/O Image Input Selection 1 and 2 Words

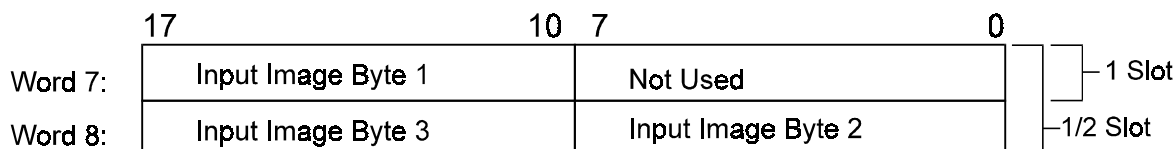

---

**NOTE:** No I/O image table is available with 2-slot addressing.

---

There are 10 types of input data that can be placed in the input image table. They are given in Chart 6-5. By entering the index numbers (see Chart 6-5) in the I/O Image Input Selection 1 and 2 words allows the Series 1771 to update the I/O image table with the specified information. By default (on power-up or initialization), the MSB of Word 7 will contain the value 1. If you want information other than the Status word (Status group) to appear in this position, you must enter the specified index number in Word 7. Figure 6-3 displays I/O Image Input Selection words set to update the input image table with the Status word and the current states of output channels 17–32.

Input Image Data Type	Index Number
Status (word 3, Status group, bits 0–7)	1
PLS Output LSB (1–8)	2
PLS Output MSB (9–16)	3
PLS Output LSB (17–24)	4
PLS Output MSB (25–32)	5
Input States	6
Position LSB	7
Position MSB	8
RPM LSB	9
RPM MSB	10

**Chart 6-5** Input Image Data Types and Their Respective Index Numbers

**NOTE:** When whole words are programmed to appear in the image table (i.e. position of RPM) this information is updated at the current scan rate of the PLC and is one scan old because both bytes in each 16 bit word are updated at the same time to maintain the integrity of the whole word. The 1771-PLS updates all other information in the I/O image table every 5 milliseconds. The actual update rate to the application would be the greater of either the 5 milliseconds or the current scan rate of the PLC.

**NOTE:** The values for the bytes described in figures 6-3 and 6-5 are shown in hexadecimal. The “0x” preceding these values is used to indicate this.

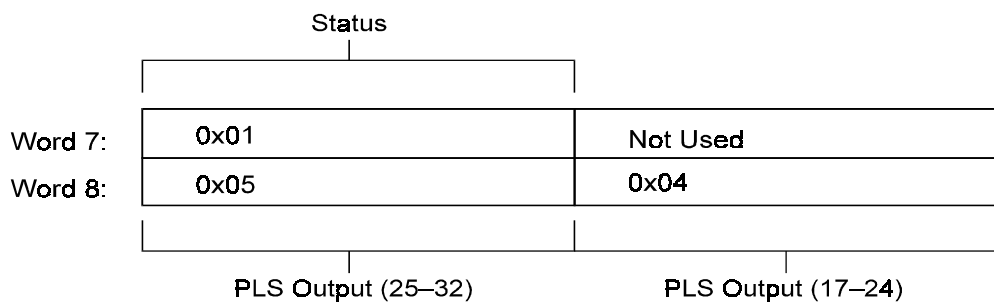

**Figure 6-3** Set I/O Image Input Selection Words

### I/O Image Output Selection 1 and 2 (words 9 and 10)

These words are used to configure which output data the PLS will receive during the current I/O scan. The assignment of these words are shown in Figure 6-4:

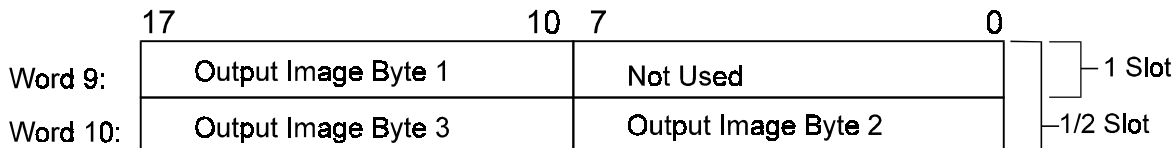
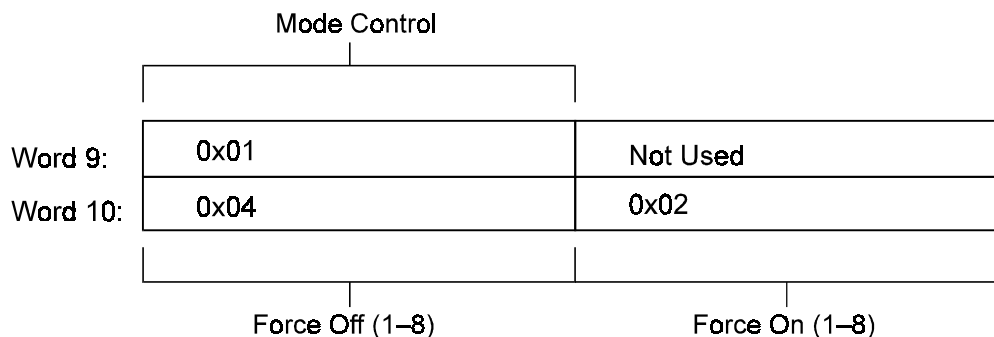

**Figure 6-4** I/O Image Output Selection 1 and 2 Words

There are five types of output data that can be placed in the output image table. They are given in Chart 6-6. By entering index numbers (see Chart 6-6) in the I/O Image Output Selection 1 and 2 words allows the Series 1771 to receive the specified data from the I/O image table with the specified information. Figure 6-5 displays I/O Image Output Selection words set to configure the output image table with the Mode Control word and forcing on and off output channels 1–8.

Output Image Data Type	Index Number
Mode Control MSB (word 1, Configuration group)	1
Force On LSB (1–8)	2
Force On MSB (9–16)	3
Force Off LSB (1–8)	4
Force Off MSB (9–16)	5

**Chart 6-6** Output Image Data Types and Their Respective Index Numbers



**Figure 6-5** Set I/O Image Output Selection Words

### Scale Factor (word 11)

This word is used to program the PLS scale factor. The scale factor is the number of increments that the PLS counts through over one rotation of the resolver. For example, a PLS based on a scale factor of 360 will count from 0 to 359 over one revolution. Valid values that can be placed in the Scale Factor word can be from 2–65535.

---

**WARNING:** Changing the scale factor will erase setpoint data in the running program. Because of this, the user should always program the PLS scale factor before programming any setpoint data or special features.

---

## Minimum RPM Disable (word 12)

This word is used to program a minimum speed (RPM) the resolver must move at or above in order for selected output channels to be enabled. If the resolver moves below the minimum speed, the PLS will disable specified output channels. Specified output channels are ones that have been programmed through the Set Speed Channels word (13). This feature can be disabled by writing a 0 to the Minimum RPM Disable word. Only ultra high-speed output channels (1–16) can be disabled based on resolver speed. For more information, see Set Speed Channels word.

## Set Speed Channels (word 13)

This word is used to program the output channels that will be controlled by the Minimum RPM Disable word. If the resolver's speed drops below the value programmed in this word, the selected output channels will be disabled. Only ultra high-speed output channels (1–16) can be selected. To select output channels, set the bits in this word which correspond to their respective output channels. For example, bit 0 corresponds to output channel 1, bit 1 corresponds to output channel 2, bit 2 corresponds to output channel 3, etc.

## Motion Detect Channel Number (word 14)

This word is used to program an output channel to be used as a motion detect output. The binary number placed in this word corresponds to the output channel number. The output channel selected will energize when the resolver is moving at or above the minimum RPM speed and de-energize when the resolver drops below the minimum RPM speed. To disable this function, set this register to 0. Output channels 1–32 can be programmed to operate as a motion detect channel. To program a minimum speed to the motion detect channel, see Motion Detect RPM Minimum (word 15).

## Motion Detect RPM Minimum (word 15)

This word is used to program the speed (RPM) at which the motion detect output channel energizes. When the resolver is moving at or above the programmed value, the motion detect channel will energize. When the resolver is moving below this programmed value, the motion detect channel will de-energize. The motion detect channel is specified in the Motion Detect Channel Number word (14). If this word contains a 0, the Motion Detect RPM Minimum word will be ignored.

## 6.3: Linear Speed Offset Group

The Linear Speed Offset group consists of 50 words (0–49). These registers are used to program linear speed offsets for output channels 1–16. The group identifier number is 3. The following is a map of the registers contained in the Linear Speed Offset group:

Word	Bit Number	Function (read/write)
0		Group Identifier (#3)
1		Output Channel
2		LS 1 RPM
3		LS 1 On Offset
4		LS 1 Off Offset
5		LS 2 RPM
6		LS 2 On Offset
7		LS 2 Off Offset
8		LS 3 RPM
9		LS 3 On Offset
10		LS 3 Off Offset
11		LS 4 RPM
12		LS 4 On Offset
13		LS 4 Off Offset
14		LS 5 RPM
15		LS 5 On Offset
16		LS 5 Off Offset
17		LS 6 RPM
18		LS 6 On Offset
19		LS 6 Off Offset
20		LS 7 RPM
21		LS 7 On Offset
22		LS 7 Off Offset
23		LS 8 RPM
24		LS 8 On Offset
25		LS 8 Off Offset
26		LS 9 RPM
27		LS 9 On Offset
28		LS 9 Off Offset
29		LS 10 RPM
30		LS 10 On Offset
31		LS 10 Off Offset
32		LS 11 RPM
33		LS 11 On Offset
34		LS 11 Off Offset
35		LS 12 RPM

Word	Bit Number	Function (read/write)
36		LS 12 On Offset
37		LS 12 Off Offset
38		LS 13 RPM
39		LS 13 On Offset
40		LS 13 Off Offset
41		LS 14 RPM
42		LS 14 On Offset
43		LS 14 Off Offset
44		LS 15 RPM
45		LS 15 On Offset
46		LS 15 Off Offset
47		LS 16 RPM
48		LS 16 On Offset
49		LS 16 Off Offset

**Chart 6-7** Linear Speed Offset Group

## Output Channel (word 1)

The number placed in this word indicates which output channel needs to be changed. A value for this word of 0 will cause all output channels' linear speed offsets to change.

## Linear Speed Offset

Figure 6-6 illustrates the format for programming an output channel with linear speed offset. Three words are used with each of the 16 output channels. The first indicates the Revolutions Per Minute (RPM), and the following two indicate the on and off offset, in that order.

**Figure 6-6** Linear Speed Offset Format

Word 2:	LS 1 RPM
Word 3:	LS 1 On Offset
Word 4:	LS 1 Off Offset

**NOTE:** Be sure to include the output channel number in the Output Channel word (1) when changing a specific output channel's linear speed offset.



## 6.4: Input Configuration Group

The Input Configuration group consists of 51 words (0–50). These words are used to configure the eight input channels on the I/O module rack, and the two I/O image inputs from the I/O image table, which correspond to bits 10 and 11 of the Mode Control word (Configuration group). Any or all of these inputs can be configured to be used as remote setpoint tuning, output enabler, and reset to preset inputs. The group identifier number is 4. The following is a map of the words contained in the Input Configuration group:

Word	Bit Number	Name (read/write)
0		Group Identifier (#4)
1		Input Type 1
2		Input 1 Output Links (1–16)
3		Input 1 (reserved)
4		Input 1 Parameter 1
5		Input 1 Parameter 2
6		Input Type 2
7		Input 2 Output Links (1–16)
8		Input 2 (reserved)
9		Input 2 Parameter 1
10		Input 2 Parameter 2
11		Input Type 3
12		Input 3 Output Links (1–16)
13		Input 3 (reserved)
14		Input 3 Parameter 1
15		Input 3 Parameter 2
16		Input Type 4
17		Input 4 Output Links (1–16)
18		Input 4 (reserved)
19		Input 4 Parameter 1
20		Input 4 Parameter 2
21		Input Type 5
22		Input 5 Output Links (1–16)
23		Input 5 (reserved)
24		Input 5 Parameter 1
25		Input 5 Parameter 2
26		Input Type 6
27		Input 6 Output Links (1–16)
28		Input 6 (reserved)
29		Input 6 Parameter 1
30		Input 6 Parameter 2
31		Input Type 7
32		Input 7 Output Links (1–16)

Word	Bit Number	Name (read/write)
33		Input 7 (reserved)
34		Input 7 Parameter 1
35		Input 7 Parameter 2
36		Input Type 8
37		Input 8 Output Links (1–16)
38		Input 8 (reserved)
39		Input 8 Parameter 1
40		Input 8 Parameter 2
41		Input Type 9
42		Input 9 Output Links (1–16)
43		Input 9 (reserved)
44		Input 9 Parameter 1
45		Input 9 Parameter 2
46		Input Type 10
47		Input 10 Output Links (1–16)
48		Input 10 (reserved)
49		Input 10 Parameter 1
50		Input 10 Parameter 2

**Chart 6-8** Input Configuration Group

## Input Type Words

These words are used to define both the functionality of the inputs and when the Input Capture words of the Status group will be updated. Bits 0–15 define the functionality of the specific input. The decimal and hexadecimal numbers which define the various functions are shown in Chart 6-9. The upper two bits (16 and 17) define the time the Input Capture words are updated. The three binary numbers for these bits are shown in Chart 6-10. The Input Type word in Figure 6-7 defines a Reset to Preset input (single shot) which will cause its respective Input Capture word to update on the leading edge of the input. For more on the various ways the inputs can be programmed, see Section 5.5: Special Purpose Inputs.

Functionality	Decimal Value	Hexadecimal Value
Not enabled	0	0x00
Remote Setpoint Tuning (Advance)	16	0x10
Remote Setpoint Tuning (Retard)	17	0x11
Input Warning Map	32	0x20
Output Enabler Input (One Shot)	32	0x20
Output Enabler Input (Level)	33	0x21
Reset to Preset Input (Standard)	48	0x30
Reset to Preset Input (Single Shot)	49	0x31

**Chart 6-9** Defining the Functionality of the Input

Update Event for Input Capture Words	Bits 16 & 17 (17 left digit, 16 right digit)
Update on through 0	00
Update on leading edge of input	01
Update on falling edge of input	10

**Chart 6-10** Defining Update Time for Input Capture Words

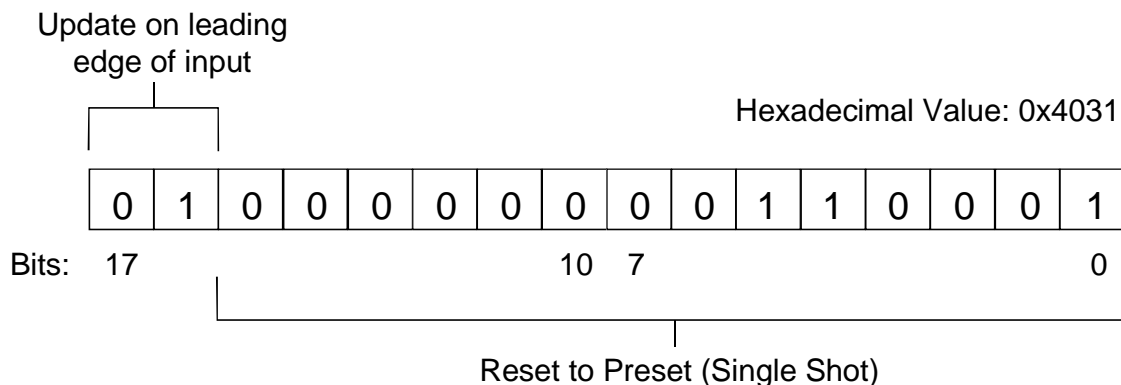

**Figure 6-7** Input Type Word Defining Type and Update Event for Input Capture Word

### Output Link Words (1–16)

These words are used to link output channels to input channels. The bits in these words correspond to the output channels. For example, bit 0 corresponds to output channel 1, bit 1 corresponds to output channel 2, etc. To link an output channel to an input, the output channel’s corresponding bit needs to be set to 1. Figure 6-8 shows one of the Output Link words with bits 0–6 set to 1. For this example, assume that the Input Type for this Output Link is defined as remote setpoint tuning.

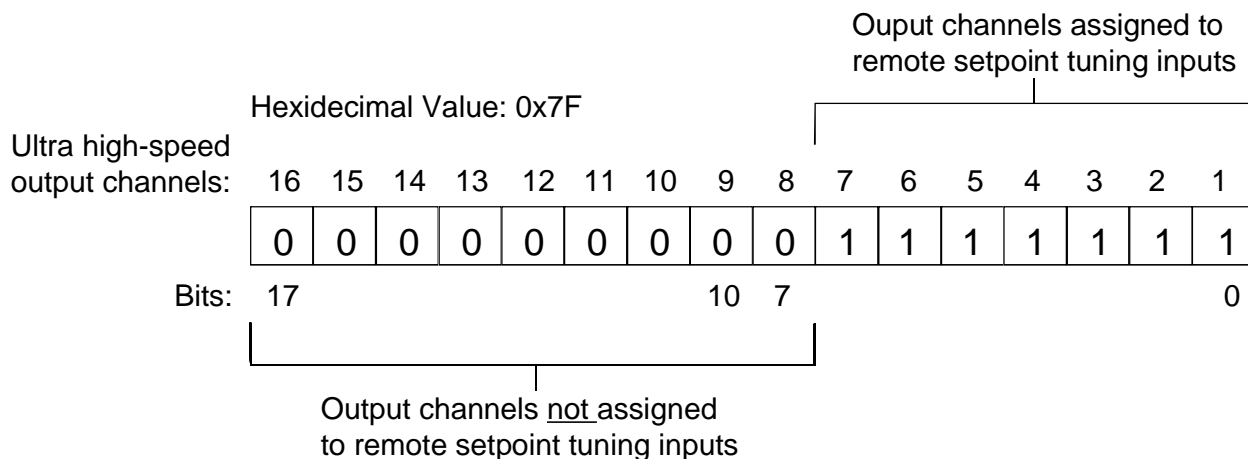

**Figure 6-8** Output Channels Assigned to Remote Setpoint Tuning Inputs

## Parameter Words

These words are used differently depending on what their respective Input Type words were defined as. If a parameter is not used for a specific input type or the input is disabled, then all unused parameter words should be set to 0. For remote setpoint tuning type inputs, the Parameter 1 word contains the number of counts the setpoints are to increment or decrement by. The Parameter 2 word is not used. For one-shot output enabler input types or input warning map use, the Parameter 1 word contains the on window position, and the Parameter 2 word contains the off window position. Parameter 1 and 2 words are not used for level output enabler input types. For reset to preset input types (both standard and single shot), the Parameter 1 word contains the preset value for the input. The Parameter 2 word is not used. Chart 6-11 summarizes the Parameter words:

Input Type	Output Links	Reserved	Parameter 1	Parameter 2
Disabled	0	0	0	0
Remote Setpoint Tuning	Linked Outputs	0	Counts	(not used)
Input Warning Map	Linked Outputs	0	Window On	Window Off
Output Enable (One Shot)	Linked Outputs	0	Window On	Window Off
Output Enable (Level)	Linked Outputs	0	0	0
Reset to Preset	Linked Outputs	0	Preset Value	(not used)

**Chart 6-11** Summary of Parameter Usage

## 6.5: Setpoint Transfer Group

The Setpoint Transfer Group consists of 64 words (0–63). These words are used to add, remove, and change setpoint data. The group identifier number is 5. The following is a map of the words contained in the Setpoint Transfer Group:

Word	Bit Number	Function (read/write)
0		Group Identifier (#5)
1		Setpoint Command
2		Number of Standard Setpoints
3		Number of Extended Setpoints
4–63		Data Words

**Chart 6-12** Setpoint Transfer Group

## Setpoint Command (word 1)

This word is used to insert one of five command numbers when transferring data to the PLS. Chart 6-13 displays valid command numbers and their descriptions:

Command Number	Description
0	Erases all setpoints programmed in the PLS.
1	Erases only setpoints specified in the Setpoint Transfer group.
2	Erases all setpoints previously programmed in the PLS, and replaces them with setpoints specified in the Setpoint Transfer group.
3	Adds setpoints specified in the Setpoint Transfer group to existing setpoints in the PLS.
4	Changes previously programmed setpoints in the PLS to new setpoints specified in the Setpoint Transfer group. In the Data words, place old on and off positions before new on and off positions of setpoint you wish to change.

**Chart 6-13** Setpoint Command Numbers

## Number of Standard Setpoints (word 2)

This word is used to specify the number of standard setpoints that are being transferred to the PLS. The order for entering an output channel's standard setpoint is illustrated in Figure 6-9. In all, it takes three words to program an output channel for a standard setpoint. Programming additional setpoints on the same output channel requires restating the output channel number prior to each additional on/off positions. If you are not programming standard setpoints, this word must be set to zero.

Word 4:	Output Channel Number
Word 5:	On Position
Word 6:	Off Position

**Figure 6-9** Standard Setpoint Format

---

**WARNING:** Any output channel programmed with an on setpoint but not a corresponding off setpoint will produce unpredictable results.

---

## Number of Extended Setpoints (word 3)

This word is used to specify the number of extended setpoints (stitching setpoints) the user wants to program to the PLS. If only standard setpoints are being programmed to the PLS, the Number of Extended Setpoints word must be set to zero.

---

**NOTE:** If standard setpoint data needs to be entered into the Data words as well as extended setpoint data, the standard setpoint data must be entered into the first group of Data words immediately followed by the extended setpoint data.

---

The order of entering stitching setpoint data is illustrated in Figure 6-10. In all, it takes four words to program an output channel for a stitching operation. The first word is used to specify the output channel number. The next two words are used to specify the positions in which the stitching operation will occur in; the beginning position is entered first. The final word is used to specify the on and off counts which determine the size of the stitches in the operation. The on count is specified in bits 10–17 of the word and the off count is specified in bits 0–7 of the word. (See also Figure 5-3.)

Word 4:	Output Channel Number
Word 5:	Beginning Position
Word 6:	Ending Position
Word 7:	On Count/Off Count

**Figure 6-10** Stitching Setpoint Format

## Data Words (4–63)

These words are used to enter setpoint data. The number of setpoints that can be transferred to the PLS in a setpoint transfer depends on the number of standard and extended setpoints that are requested, since these types of setpoints require different numbers of words. When sending both standard and extended setpoints to the PLS, data for standard setpoints must be entered in the first group of data registers. Further, the number of standard setpoints must be specified in the Number of Standard Setpoints word (2). If only standard setpoints are going to be transferred to the PLS, then the Number of Extended Setpoints word (3) must be zero; if only extended setpoints are going to be transferred to the PLS, then the Number of Standard Setpoints word (2) must be zero.

## 6.6: Command Group

The Command group consists of 7 words (0–6). These words are used to send commands and command parameters to the PLS. The group identifier number is 6. The following is a map of the words contained in the Command group:

Word	Bit Number	Name (write only)
0		Group Identifier (#6)
1		Command
2		Command Parameter 1
3		Command Parameter 2
4		Command Parameter 3
5		Command Parameter 4
6		Command Parameter 5

**Chart 6-14** Command Group

### Command (word 1)

This word is the actual command being sent to the PLS. For a listing of the commands the command word accepts, see Section 6.8: Commands.

### Command Parameters 1–5 (words 2–6)

These words are used in conjunction with the Command word (1). They are used to pass parameters a command requires. Five words are provided to send up to five parameters per command. For a listing of commands requiring parameters, see Appendix B: Command Summary Chart or Section 6.8: Commands.

## 6.7: Fault History Group

The Fault History group consists of 31 words (0–30). These words are used to contain all valid error codes, if any occur, and the time that the errors occurred. This information can be requested by entering the Fault History group identifier number in the Block Transfer Read Group Identifier word (Configuration group). Up to 15 error codes are recorded before the first error code to be recorded in the stack is forced out to make room for the next error code. Valid error codes and their descriptions can be found in the Fault and Warning subsections of Section 6.1: Status Group. The Fault History group identifier number is 7. The following is a map of the words contained in the Fault History group:

Word	Bit Number	Name (write only)
0		Group Identifier (#7)
1		Error Code 1
2		Error Time 1
3		Error Code 2
4		Error Time 2
5		Error Code 3
6		Error Time 3
7		Error Code 4
8		Error Time 4
9		Error Code 5
10		Error Time 5
11		Error Code 6
12		Error Time 6
13		Error Code 7
14		Error Time 7
15		Error Code 8
16		Error Time 8
17		Error Code 9
18		Error Time 9
19		Error Code 10
20		Error Time 10
21		Error Code 11
22		Error Time 11
23		Error Code 12
24		Error Time 12
25		Error Code 13
26		Error Time 13
27		Error Code 14
28		Error Time 14
29		Error Code 15
30		Error Time 15

**Chart 6-15** Fault History Group



## Error Code Words

These words are used to record all valid error codes. Up to 15 error codes can be recorded before the first error in the group is forced out of the stack when a 16th error occurs. Valid error codes and their descriptions can be found in Section 6.1: Status Group in the Fault and Warning condition subsections.

## Error Time Words

These words are used to record the time an error had occurred. The time recorded in each Error Time word corresponds to its respective Error Code word. A real-time clock does not exist in the Series 1771. The time begins at zero when the unit is shipped and increments in seconds during run time. When the unit is not running, the time remains at its last value before the unit stops. This time continues to increment from its last saved value during its next run time.

# 6.8: Commands

This section describes the commands the PLS supports. These commands or command numbers are written in the Command word (see Section 6.6: Command Group). In addition, some commands require parameters. Up to five parameters can be passed per command. This is accomplished by writing parameters in the five Command Parameter words which follow the Command word.

## 1 Initialize

The Initialize command completely initializes the PLS. All data entered in the Configuration, Linear Speed Offset, Input Configuration, and Setpoint Transfer groups will be erased from memory. In order to execute this command, the value 0x5A5A must be passed into the Command Parameter 1 word and the value 0xABCD must be passed into the Command Parameter 2 word.

## 2 Reset

The Reset command causes the PLS to return to the power-up reset state. If there is a valid program in nonvolatile memory, this program will be loaded and prepared to run.

## 40 Save

The Save command saves to nonvolatile memory the program currently running on the PLS. This command also assigns a program number to the program. Place the program number in the Command Parameter 1 word before issuing the command number. The program number is similar to a version number. The PLS does not have multiple program capability. Therefore, the program number is simply used as an identifier for the program.

## 50 Restore

The Restore command restores a program's data saved in nonvolatile memory. Any changes made to the program after the program was last saved will be overwritten by the data stored in nonvolatile memory.

## 62 List Setpoints

The List Setpoints command retrieves a record of all existing setpoints programmed in the PLS. To retrieve the data, the PLS places the setpoint data in the Setpoint Transfer group. In order to retrieve this information, enter the number of standard setpoints you wish to read in bits 10–17 of the Command Parameter 1 word with the setpoint index (starting position) in bits 0–7 of the same word; the number of extended setpoints you wish to read in bits 10–17 of the Command Parameter 2 word with the setpoint index in bits 0–7 of the same word; and the output channel number that has the programmed setpoints in the Command Parameter 3 word. Figure 6-11 illustrates what needs to be entered into the Command group when using the List Setpoint command:

	17	10	7	0
Word 0:	Group Identifier Number : #6 (Command Group)			
Word 1:	Command: #62 (List Setpoints)			
Word 2:	Number of Standard Setpoints		Standard Setpoint Index	
Word 3:	Number of Extended Setpoints		Extended Setpoint Index	
Word 4:	Output Channel Number			

**Figure 6-11** List Setpoint Command

After sending the List Setpoint command, a block transfer read of the Setpoint Transfer group is required. This will return the requested number of setpoints, beginning with the specified indexed setpoint (starting position), for the specified output channel. See Figure 6-12. Because there are only 59 Data Words in the Setpoint Transfer group, the setpoint data returned (output channel, on position, off position [in this order for each on/off position]) can only go to 59 words. If the output channel contains more setpoints, another List Command will need to be reissued. Another required read can be determined by comparing the lower bytes of words 3 and 4 (Setpoint Transfer group) with the higher bytes of words 3 and 4, respectively. The higher bytes indicate the number of setpoints that have not been read. If the higher bytes contain the value 0, all bytes were read. However, if these bytes contain a value greater than 0, the values contained in these bytes indicate the number of setpoints that have not yet been read. In this case, the next index numbers for the last standard and extended setpoints that were retrieved will need to be entered in bits 0–7 of the Command Parameter 1 and 2 words for the next List Setpoint command.

		Setpoint Transfer Group															
		17										10 7		0			
Word 0:		0	0	0	0	0	0	0	0	0	0	0	0	0	1	0	1
Word 1:		0	0	0	0	0	0	0	0	0	0	0	0	0	0	0	0
Word 2:		Number of standard setpoints that remain to be read.										Number of standard setpoints read.					
Word 3:		Number of extended setpoints that remain to be read.										Number of extended setpoints read.					
Word 4:		Setpoint data in the order of channel number, on position, and off position.															

**Figure 6-12** Setpoint Data Retrieved Through a Block Transfer Read

## 90 Set Home (Offset)

The Set Home command is used to synchronize the PLS position with the actual machine position. With the machine stopped at a known position, the position that the PLS should be set to is entered in the Command Parameter 1 word.

## 6.9: Application Examples

This section provides example applications to assist you in creating your own applications for the Series 1771 PLS module. The first example can be used as a guide for initializing and configuring the PLS, sending setpoints, saving, enabling the PLS, and finally programming the PLS to perform a continuous block transfer read to monitor the module's status. Following this program are two examples to assist you in changing standard and extended setpoints. Please note that all data sent through block transfer writes follow their respective example applications.

**NOTE:** The following application examples assume the Series 1771 PLS is located at group 6, module 0, in a rack set up for 1/2 slot addressing.

The first step is to send the Initialization command to the PLS. This is done by sending a block transfer write of the Command group containing the Initialization command number (1) and its required parameters. The command is stored in N27:1. To see the data stored in this integer file, see Data File N27:0–6 following the application.

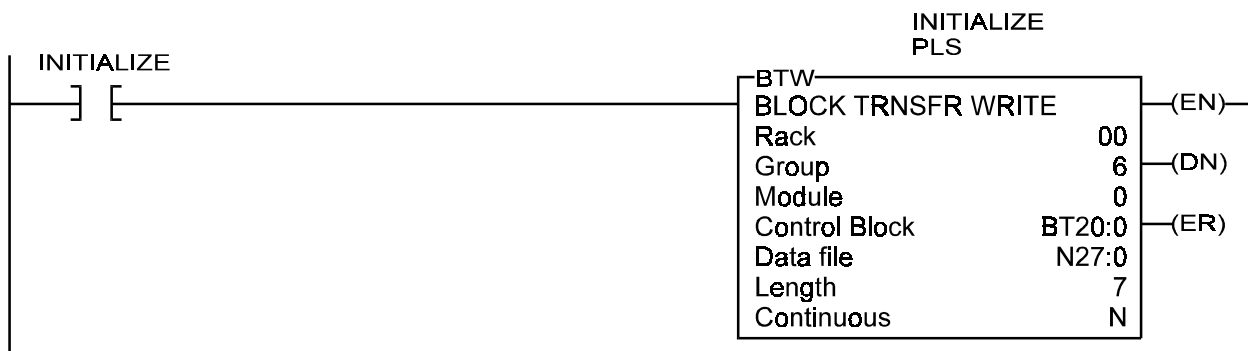

The next step is to send the Configuration group containing all configuration data through a block transfer write. The following rung will send the Configuration group which will program the scale factor to 360. It will also define the parameters that go into the I/O image table and also define the Block Transfer Read Group Identifier. For values placed in the Configuration group, see Data File N23.

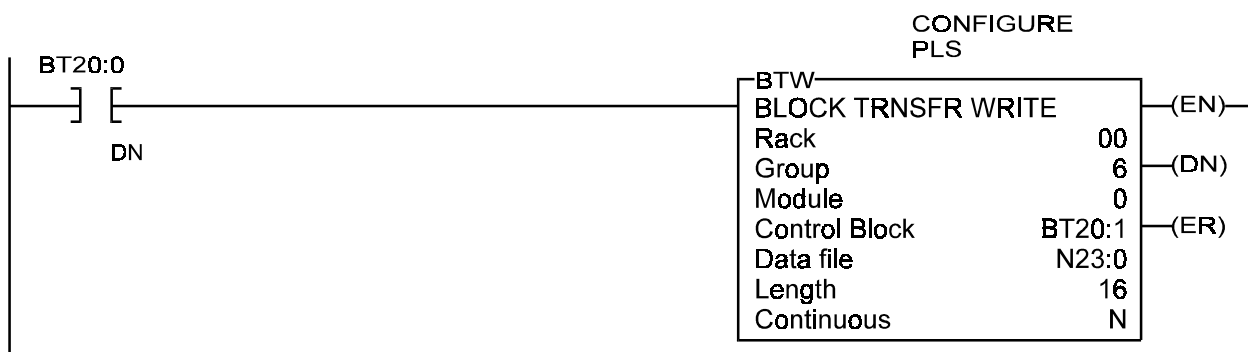

The next step is to configure the eight inputs on the PLS. This is done by sending the Input Configuration group through a block transfer write. To see all data sent, see Data File N25 following this application.

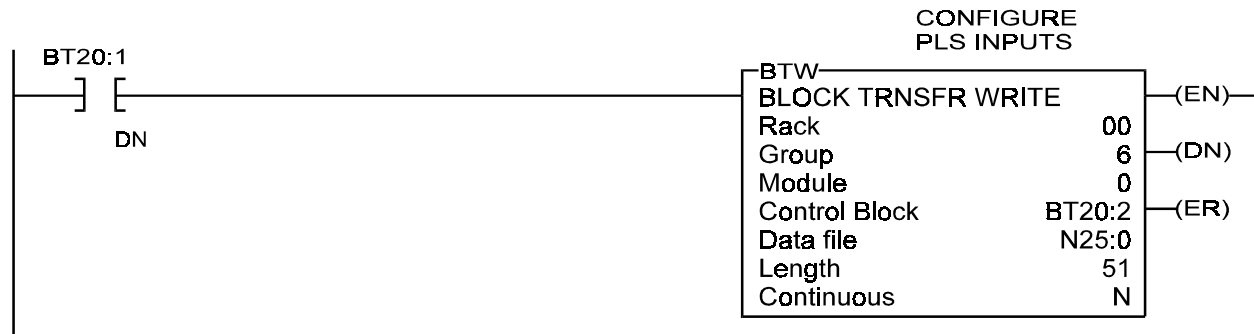

After configuring the PLS, the following rung sends setpoints contained in the Setpoint Transfer group to the PLS. See Data File N26 for setpoint data following this application.

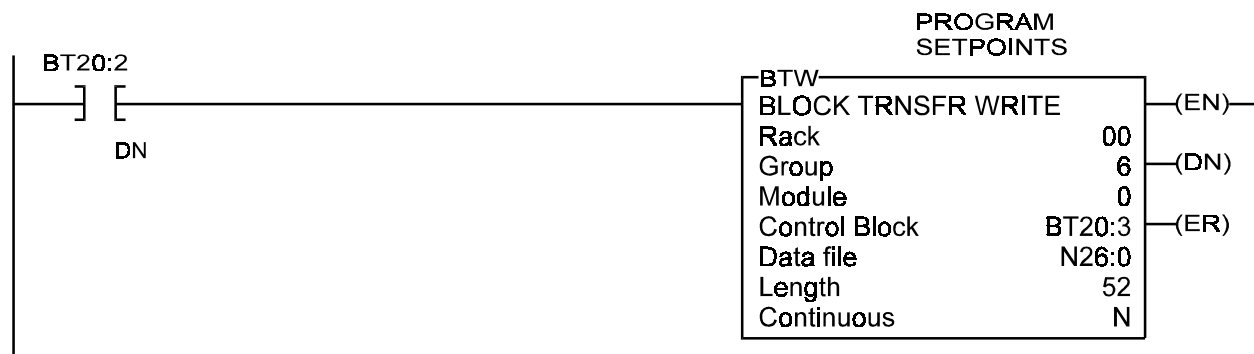

When the setpoints have been sent to the PLS, the following rung issues a Save command to copy all the information into nonvolatile memory. This is done by sending a block transfer write of the Command group containing the Save command number (40) and its program identifier number, in this case, 1. The command is stored in N27:8. To see the data stored in this integer file, see Data File N27:7–13.

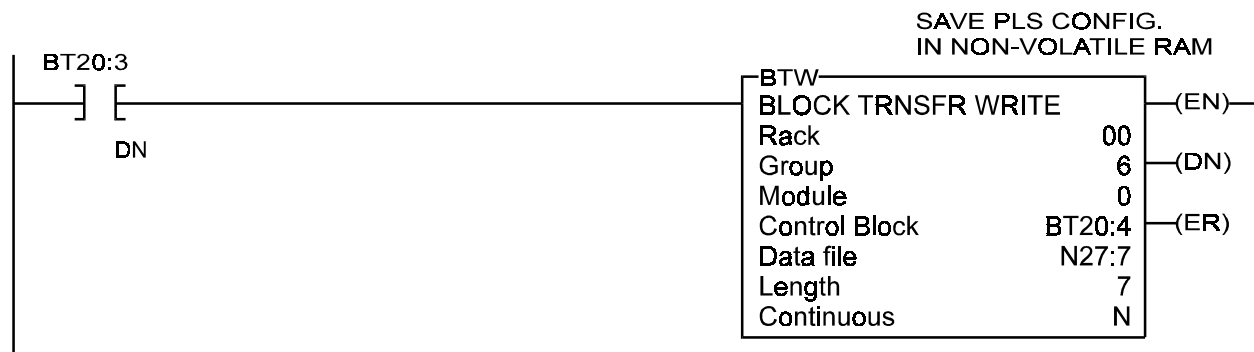

When the data has been saved, the following rung issues a Set Home command (90) to position the resolver. See Data File N27:14–20.

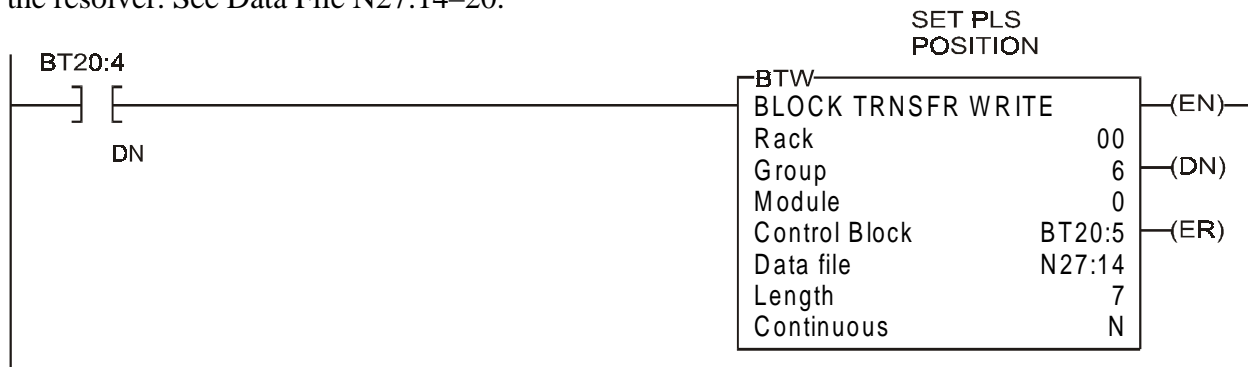

After resetting the position, the following rung enables the PLS through the I/O image table and monitors the Status group through a block transfer read. See Data File N21.

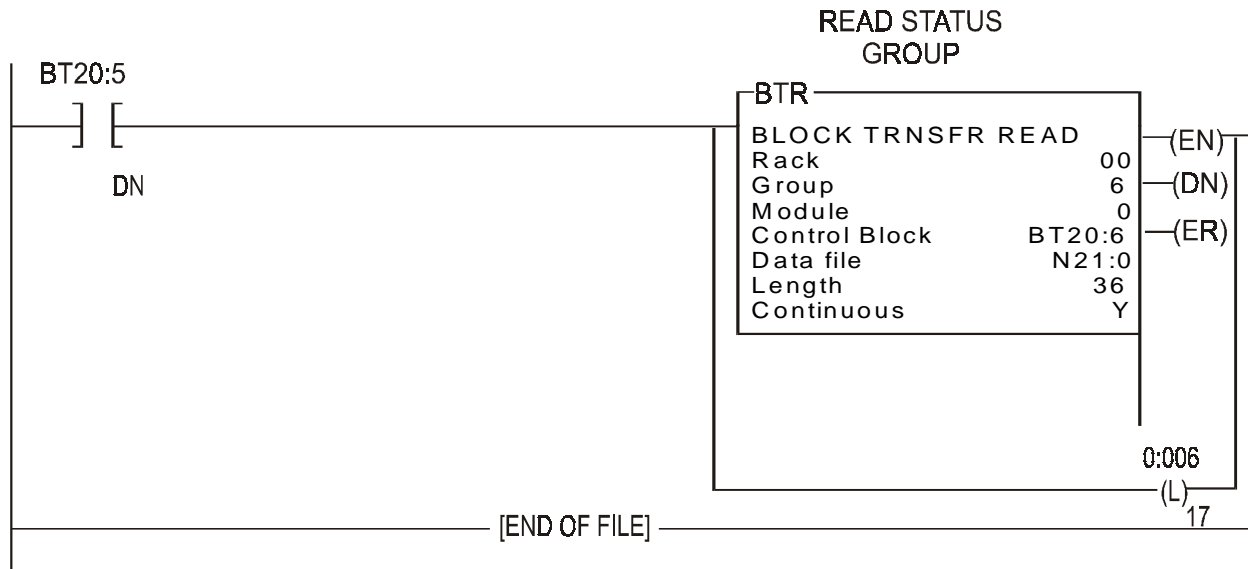

## Data File N27:0–6

Command Group:

N27:0	6	Group Identifier (Command)
N27:1	1	Initialize Command
N27:2	23130	Parameter 1: Code (0x5A5A)
N27:3	-21555	Parameter 2: Code (0xABCD)
N27:4	0	
N27:5	0	
N27:6	0	

## Data File N23:0–15

### Configuration Group:

N23:0	2	Group Identifier (Configuration)
N23:1	0	Mode Control
N23:2	0	Force On (LS32-LS17)
N23:3	0	Force On (LS16-LS1)
N23:4	0	Force Off (LS32-LS17)
N23:5	0	Force Off (LS16-LS1)
N23:6	1	Block Transfer Read Group Identifier (Identifies the Status group)
N23:7	256	I/O Image Input Selection 1 (x0100)
N23:8	1284	I/O Image Input Selection 2 (x0504)
N23:9	256	I/O Image Output Selection 1 (x0100)
N23:10	0	I/O Image Output Selection 2 (x0000)
N23:11	360	Scale Factor
N23:12	0	Output Enable RPM Minimum
N23:13	0	Set Speed Channels
N23:14	0	Motion Detect Channel Number
N23:15	0	Motion Detect RPM Minimum

## Data File N25:0–50

### Input Configuration Group:

N25:0	4	Group Identifier (Input Configuration)
N25:1	16	Input 1 Type: Remote Setpoint Tuning - Advance
N25:2	3	Output Links: Channels 1 and 2
N25:3	0	Reserved
N25:4	1	Parameter 1: Advance 1 count
N25:5	0	Parameter 2
N25:6	17	Input 2 Type: Remote Setpoint Tuning - Retard
N25:7	3	Output Links: Channels 1 and 2
N25:8	0	Reserved
N25:9	1	Parameter 1: Retard 1 count
N25:10	0	Parameter 2
N25:11	32	Input 3 Type: Output Enable Input - One-shot
N25:12	12	Output Links: Channels 3 and 4
N25:13	0	Reserved
N25:14	100	Parameter 1: Window On
N25:15	200	Parameter 2: Window Off
N25:16	33	Input 4 Type: Output Enable Input - Level
N25:17	48	Output Links: Channels 5 and 6
N25:18	0	Reserved
N25:19	0	Parameter 1
N25:20	0	Parameter 2
N25:21	48	Input 5 Type: Reset to Preset Input - Standard

N25:22	192	Output Links: Channels 7 and 8
N25:23	0	Reserved
N25:24	0	Parameter 1: Reset to 0
N25:25	0	Parameter 2
N25:26	49	Input 6 Type: Reset to Preset Input - Single-shot
N25:27	768	Output Links: Channels 9 and 10
N25:28	0	Reserved
N25:29	180	Parameter 1: Reset to 180
N25:30	0	Parameter 2
N25:31	0	Input 7 Type: Disabled
N25:32	0	Output Links
N25:33	0	Reserved
N25:34	0	Parameter 1
N25:35	0	Parameter 2
N25:36	0	Input 8 Type: Disabled
N25:37	0	Output Links
N25:38	0	Reserved
N25:39	0	Parameter 1
N25:40	0	Parameter 2
N25:41	0	Input 9 Type: Disabled
N25:42	0	Output Links
N25:43	0	Reserved
N25:44	0	Parameter 1
N25:45	0	Parameter 2
N25:46	0	Input 10 Type: Disabled
N25:47	0	Output Links
N25:48	0	Reserved
N25:49	0	Parameter 1
N25:50	0	Parameter 2

## Data File N26:0–51

### Setpoint Transfer Group:

N26:0	5	Group Identifier (Setpoint Transfer)
N26:1	3	Command: Add setpoints
N26:2	16	Number of standard setpoints
N26:3	0	Number of extended setpoints

	Channel #	On Pos	Off Pos
N26:4	1	11	191
N26:7	2	22	202
N26:10	3	33	213
N26:13	4	44	224
N26:16	5	55	235
N26:19	6	66	246



N26:22	7	77	257
N26:25	8	88	268
N26:28	9	99	279
N26:31	10	110	290
N26:34	11	121	301
N26:37	12	132	312
N26:40	13	143	323
N26:43	14	154	334
N26:46	15	165	345
N26:49	16	176	356

## Data File N27:7–13

### Command Group:

N27:7	6	Group Identifier (Command)
N27:8	40	Save Command
N27:9	1	Parameter 1: Program Number
N27:10	0	
N27:11	0	
N27:12	0	
N27:13	0	

## Data File N27:14–20

### Command Group:

N27:14	6	Group Identifier (Command)
N27:15	90	Home Command
N27:16	0	Parameter 1: Position (set to zero)
N27:17	0	
N27:18	0	
N27:19	0	
N27:20	0	

## Data File N21:0–35 (As Read From the PLS)

### Status Group:

N21:0	1	Group Identifier (Status)
N21:1	1	Hardware Version (actual version may vary)
N21:2	4	Software Version (actual version may vary)
N21:3	132	Status Word
N21:4	0	Fault Condition
N21:5	0	Warning Condition
N21:6	1	Current File Number
N21:7	0	Current File CRC
N21:8	0	Current Position

N21:9	0	Current RPM
N21:10	0	Input Image
N21:11	3	Remote Setpoint Tune Channels
N21:12	0	PLS Outputs (LS32 - LS17)
N21:13	0	PLS Outputs (LS16 - LS1)
N21:14	0	Input 1 Up Capture
N21:15	0	Input 1 Down Capture
N21:16	0	Input 2 Up Capture
N21:17	0	Input 2 Down Capture
N21:18	0	Input 3 Up Capture
N21:19	0	Input 3 Down Capture
N21:20	0	Input 4 Up Capture
N21:21	0	Input 4 Down Capture
N21:22	0	Input 5 Up Capture
N21:23	0	Input 5 Down Capture
N21:24	0	Input 6 Up Capture
N21:25	0	Input 6 Down Capture
N21:26	0	Input 7 Up Capture
N21:27	0	Input 7 Down Capture
N21:28	0	Input 8 Up Capture
N21:29	0	Input 8 Down Capture
N21:30	0	Input 9 Up Capture
N21:31	0	Input 9 Down Capture
N21:32	0	Input 10 Up Capture
N21:33	0	Input 10 Down Capture
N21:34	0	Input Transistion Map
N21:35	0	Input Warning Map

## Block Transfer Data:

All of the data for the block transfers in the previous application is stored in a block transfer file. This file is shown below:

Address	EN	ST	DN	ER	CO	EW	NR	TO	RW	RLEN	DLEN	FILE	ELEM	R	G	M
BT20:0	0	0	0	0	0	0	0	0	0	7	7	27	0	00	6	0
BT20:1	0	0	0	0	0	0	0	0	0	16	16	23	0	00	6	0
BT20:2	0	0	0	0	0	0	0	0	0	51	51	25	0	00	6	0
BT20:3	0	0	0	0	0	0	0	0	0	52	52	26	0	00	6	0
BT20:4	0	0	0	0	0	0	0	0	0	7	7	27	7	00	6	0
BT20:5	0	0	0	0	0	0	0	0	0	7	7	27	14	00	6	0
BT20:6	0	0	0	0	1	0	0	0	1	36	36	21	0	00	6	0

The following block transfer will change a setpoint programmed in the PLS from an on position of 11 and an off position of 191, to an on position of 100 and an off position of 200. The old setpoint must be entered so the PLS knows which one to change.

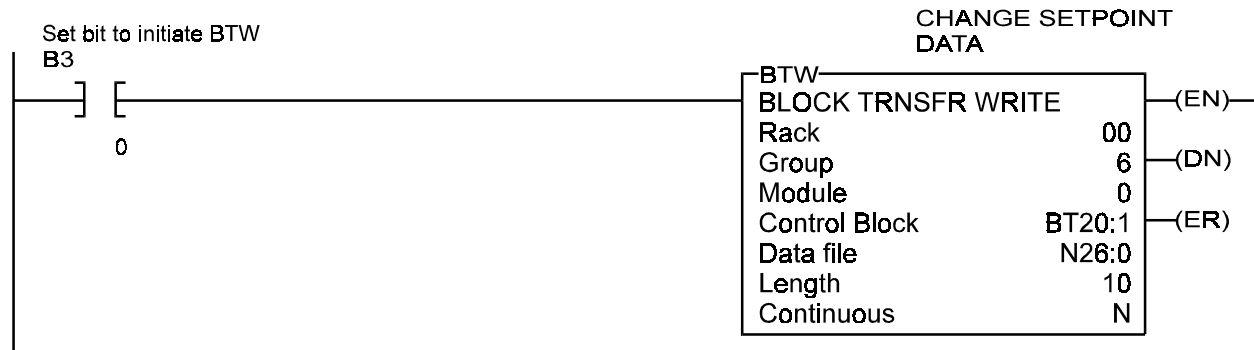

Setpoint Transfer Group:

- N26:0        5        Group Identifier (Setpoint Transfer)
- N26:1        4        Command: Change Setpoints
- N26:2        1        Number of standard setpoints
- N26:3        0        Number of extended setpoints

	Channel #	On Pos	Off Pos	
N26:4	1	11	191	(Old Setpoint)
N26:7	1	100	200	(New Setpoint)

**NOTE:** Channel numbers must match. You cannot change a setpoint in channel 1 to a setpoint in channel 2.

The following example shows how the Setpoint Transfer group data looks with extended setpoint data. Channels 1–8 have standard setpoints, while channels 9–16 have extended setpoints:

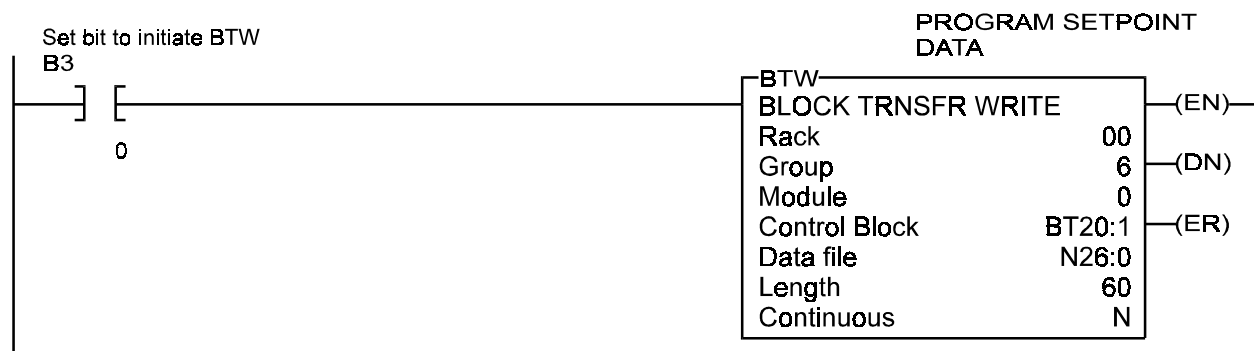

**Setpoint Transfer Group:**

N26:0	5	Group Identifier
N26:1	3	Command: Add setpoints
N26:2	8	Number of standard setpoints
N26:3	8	Number of extended setpoints

	Channel #	On Pos	Off Pos	
				On Cnt/Off Cnt
N26:4	1	11	191	
N26:7	2	22	202	
N26:10	3	33	213	
N26:13	4	44	224	
N26:16	5	55	235	
N26:19	6	66	246	
N26:22	7	77	257	
N26:25	8	88	268	
N26:28	9	100	200	2570
N26:32	10	110	210	2570
N26:36	11	120	220	2570
N26:40	12	130	230	2570
N26:44	13	140	240	2570
N26:48	14	150	250	2570
N26:52	15	160	260	2570
N26:56	16	170	270	2570

---

**NOTE:** The extended setpoints *must* immediately follow the standard setpoints.

---

# Appendix A: Troubleshooting

There are two types of errors that can occur with the Series 1771 PLS module: faults and warnings.

**Fault** This type of error usually is the result of the resolver failing to operate properly or an error with the PLS's internal hardware. The exact cause can be determined by examining the Fault Condition's error code. The Fault Condition word (Status group) will hold the error code until the PLS receives another command. Chart 6-2 (see Section 6.1: Status Group) contains possible error codes. Perform the troubleshooting steps found in the following subsections of this appendix.

**Warning** This type of error usually is a result of an invalid parameter being written to one of the words in a block transfer write. The exact cause can be determined by examining the Warning Condition's error code. The Warning Condition word (Status group) will hold the error code until the PLS receives another command. Chart A-1, found at the end of this appendix, contains possible error codes with explanations and solutions.

---

**NOTE:** If PLS outputs do not appear to be working correctly on the I/O rack, but are turning on the LEDs on the module, verify the 1A fuse on the I/O rack is installed in the position closest to the ribbon connector.

---

---

## Primary Shorted

The resolver's rotor coil receives a voltage from the PLS. This rotor coil then feeds the stator coils, which gives a ratiometric feedback used to calculate position. If bit 2 in the Fault Condition word is set (assuming bit 10 is also set), the resolver's primary coil may be shorted. Perform the following steps:

1. Confirm resolver wire connections are secure and properly connected.
2. If the PLS is the only controller attached to the resolver, or is the master of a master/slave configuration which is connected to a single resolver, confirm that Switch 4 of SW1 on the PLS card is in the open position. (See Figure 3-1 for position of switch.)
3. Clear and set the PLS Run Enable bit (17) in the Mode Control word (Configuration group). If the Fault LED turns off and the PLS begins to run, the problem has been resolved. If the Fault LED does not turn off, continue to the next step.
4. With a digital voltmeter set to AC, check the voltages across the red and black of red wires connected to the PLS. The voltage level should be between 3.6 and 5.0 VAC. If the voltage is at 0, continue to the next step.
5. Remove the red and black of red wires from their terminals. With the voltmeter still set to AC, check the voltages across the terminals that the red and black of red wires were previously connected to. If no voltage is present, the resolver drive circuit has been damaged. Contact Gemco for further assistance. However, if the voltage level is present, continue to the next step.
6. Set the digital voltmeter to resistance (ohms  $\Omega$ ). With the red and black of red wires still removed from their terminals, check the circuit resistance across these wires. Normal readings will be approximately 16–50 ohms. If the reading is low, check the resolver cable for shorts. Remove the connector at the resolver and check for a low resistance between the red and black of red wires. For pinout details, see Figure 3-2. If the cable check proves correct yet a low resistance is seen when connected to the resolver, it is likely that the resolver rotor coil has been shorted. Contact Gemco for further assistance.

## Primary Open

The resolver's rotor coil receives a voltage from the PLS. This rotor coil then feeds the stator coils, which gives a ratiometric feedback used to calculate position. If bit 3 in the Fault Condition word is set (assuming bit 10 is also set), the resolver's primary coil may be open. Perform the following steps:

1. Confirm resolver wire connections are secure and properly connected.
2. If the PLS is the only controller attached to the resolver, or is the master of a master/slave configuration which is connected to a single resolver, confirm that Switch 4 of SW1 on the PLS card is in the open position. (See Figure 3-1 for position of switch.)
3. Clear and set the PLS Run Enable bit (17) in the Mode Control word (Configuration group). If the Fault LED turns off and the PLS begins to run, the problem has been resolved. If the Fault LED does not turn off, continue to the next step.
4. With a digital voltmeter set to AC, check the voltages across the red and black of red wires connected to the PLS. The voltage level should be between 3.6 and 5.0 VAC. If voltage is at 0, continue to the next step.
5. Remove the red and black of red wires from their terminals. With the voltmeter still set to AC, check across the terminals that the red and black of red wires were previously connected to. If no voltage is present, the resolver drive circuit has been damaged. Contact Gemco for further assistance. However, if the voltage level is present, continue to the next step.
6. Set the digital voltmeter to resistance (ohms  $\Omega$ ). With the red and black of red wires still removed from their terminals, check the circuit resistance across these wires. Normal readings will be approximately 16–50 ohms. If the reading is higher than 50 ohms, remove the connector at the resolver and check for zero ohm continuity across both ends of each wire. For pinout details, see Figure 3-2. If the cable check proves correct yet a high resistance is seen when connected to the resolver, it is likely that the resolver primary coil is open. Contact Gemco for further assistance.

---

## S1 Open

The stator coils (two total) generate a ratiometric analog signal output. The outputs are fed into an analog-to-digital converter in the PLS where the phase shift relationship of the stator signals is compared and accurately converted to a rotational position. If either bit 1 in the Fault Condition word is set (assuming bit 10 is also set), perform the following steps:

1. Confirm resolver wire connections are secure and properly connected.
2. Clear and set the PLS Run Enable bit (17) in the Mode Control word (Configuration group). If the Fault LED turns off and the PLS begins to run, the problem has been resolved. If the Fault LED does not turn off, continue to the next step.
3. With a digital voltmeter set to AC, check the voltages across the white and black of white wires connected to the PLS. The voltage level should be between 0 and 4.7 VAC, depending on the resolver's position. Slowly rotate the resolver while checking the voltage levels. Within one revolution of the resolver, the voltage should make a cycle from 0 to 5 volts. If no voltage is seen, perform steps 4 and 5.
4. With the digital voltmeter still set to AC, check across the red and black of red wires connected to the PLS to make sure a voltage between 3.6 and 5.0 VAC is present. If no voltage is seen, continue to the next step.
5. Using the cable pinout shown in Figure 3-2, disconnect the cable at the PLS and resolver and check for continuity or shorts in the green and black of green and the white and black of white twisted pairs.
6. To check for an open or shorted condition inside of the resolver, disconnect the amphenol-style connector from the resolver and make the following checks at the resolver: Measure the resistance across pins A and B (rotor); it should measure approximately 16–50 ohms. Then measure across pins C and D (stator); it should measure approximately 50–120 ohms. The resistance across E and F should be the same as C and D.
7. Reconnect Resolver.
8. Clear and set the PLS Run Enable bit (17) in the Mode Control word (Configuration group). If the Fault Condition word does not clear, the circuitry may be damaged. Contact Gemco for further assistance.



## S4 Open

The stator coils (two total) generate a ratiometric analog signal output. The outputs are fed into an analog-to-digital converter in the PLS where the phase shift relationship of the stator signals is compared and accurately converted to a rotational position. If bit 0 in the Fault Condition word is set (assuming bit 10 is also set), perform the following steps:

1. Confirm resolver wire connections are secure and properly connected.
2. Clear and set the PLS Run Enable bit (17) in the Mode Control word (Configuration group). If the Fault LED turns off and the PLS begins to run, the problem has been resolved. If the Fault LED does not turn off, continue to the next step.
3. With a digital voltmeter set to AC, check the voltage across the green and black of green wires connected to the PLS. The voltage level should be between 0 and 4.7 VAC, depending on the resolver's position. Slowly rotate the resolver while checking the voltage levels. Within one revolution of the resolver, the voltage should make a cycle from 0 to 5 volts. If no voltage is seen, perform steps 4 and 5.
4. With the digital voltmeter still set to AC, check across the red and black of red wires connected to the PLS to make sure a voltage between 3.6 and 5.0 VAC is present. If no voltage is seen, continue to the next step.
5. Using the cable pinout shown in Figure 3-2, disconnect the cable at the PLS and resolver and check for continuity or shorts in the green and black of green wires and the white and black of white wires.
6. Remove the white and black of white wires from their terminals on the PLS faceplate. With the digital voltmeter still set to AC, check the voltage levels across the green and black of green wires and the white and black of white wires. If no voltage is present, the resolver's stator is likely open and will need to be replaced. If voltage is present, reconnect the wires making sure the wires are securely connected.
7. Reconnect Resolver.
8. Clear and set the PLS Run Enable bit (17) in the Mode Control word (Configuration group). If the Fault Condition word does not clear, the circuitry may be damaged. Contact Gemco for further assistance.

## Warning Condition (word 5)

This word indicates the type of error that occurred which caused the Warning bit of the Status word (Status group) to be set. The cause of a warning error usually is a result of an invalid parameter being written to one of the words in a block transfer write. The exact cause can be determined by examining the Warning Condition's error code. The Warning Condition will hold the error code until the PLS receives another block transfer write. Chart A-1 contains possible error codes with explanations and solutions:

Warning Condition Code	Explanation	Solution
2	There are no setpoints programmed.	The Initialize command was sent to the PLS prior to run time or the scale factor was changed. Both acts erase all existing setpoints. Recreate a setpoint file.
3	The PLS ran out of RAM while trying to add setpoints.	Contact Patriot Sensors & Controls.
100	An invalid format, wrong channel number, or invalid on/off positions were written in a setpoint.	Check setpoints used in program for incorrect channel numbers, on/off positions, or improper format use. Refer to Section 6.5: Setpoint Transfer group for further assistance.
101	One or more invalid parameters were found in one or more of the Command Parameter words.	Write a valid parameter or parameters to the Command Parameter words with the command you are sending. Refer to Section 6.8: Commands for further assistance.
102	A command was sent to change or delete a setpoint that does not exist.	Check for wrong channel number or on/off positions in setpoint(s) you are trying to change or delete.
103	The Add command was sent to add a setpoint that already exists.	Check your setpoint file for redundant setpoints.
104	The scale factor in the Configuration Group is invalid.	Write a scale factor that is within the valid range. Refer to Section 6.2: Configuration Group to determine the scale factor's range.
105	An invalid command number was written to the Command word.	Write the correct Command number to the Command word. Refer to Section 6.8: Commands for further assistance.

<b>Warning Condition Code</b>	<b>Explanation</b>	<b>Solution</b>
<b>106</b>	A group identifier number received in a block transfer write is invalid, or the read block group identifier number in the Configuration group is invalid.	Check for an illegal group identifier number as well as for a wrong group identifier number placed in the Block Transfer Read Group Identifier word (Configuration group).
<b>107</b>	The data size of a block transfer does not match the size of the group specified by the group identifier number.	Verify that the proper group identifier number was used in the block transfer and whether too much or too little data was used in the transfer.
<b>108</b>	The data that was requested to be assigned to the input image table is invalid.	Verify the validity of the data.
<b>109</b>	The data that was requested to be assigned to the output image table is invalid.	Verify the validity of the data.
<b>110</b>	The channel number sent in the Linear Speed Offset group is invalid.	Send the correct channel number.
<b>111</b>	The change setpoint command tried to change a setpoint from one channel to another channel.	Channel numbers must match.
<b>112</b>	The input type sent in the Input Configuration group is invalid.	Verify the input data type for all input channels.

**Chart A-1** Warning Condition Error Codes

---

**NOTE:** For a list of Fault Condition Codes, see Chart 6-2.

---

# Appendix B: Command Summary Chart

The following chart describes the command numbers that the PLS supports. Some of these commands require parameters. Up to five parameters can be passed per command. The chart indicates which commands require parameters. For more information on these commands, see Section 6.6: Command Group and Section 6.8: Commands.

Command Number	Command Name	Parameters Used	Descriptions and Instructions
1	Initialize	Command Parameter 1 and 2	This command completely resets and initializes the PLS.
2	Reset		This command causes the PLS to return to the power-up reset state. If there is a valid program in nonvolatile memory, this program will be loaded and prepared to run.
40	Save	Command Parameter 1	This command saves the program currently running on the PLS to nonvolatile memory.
50	Restore		This command restores a program's data saved in nonvolatile memory.
62	List Setpoints	Command Parameter 1, 2, and 3	This command writes the number of on/off setpoints that were programmed for a specific output channel.
90	Set Home (Offset)	Command Parameter 1	This command is used to synchronize the PLS position with the actual machine position.

**Chart B-1** Command Summary

# Appendix C: Specifications

## PLS Module

Power Requirements:	5 VDC 1771 backplane power 10 watts maximum
Resolution:	14-bit (16,384), scale factor of 2–65535 (optional)
Temperature Range:	Operating: 32–131°F (0–55°C) Storage: 0–150°F (-17–65°C)
Update Time:	
Direct Outputs	Channels 1 - 16: 5 microseconds
Internal Updates	Channels 17 - 32: 500 microseconds Position for PLC: 500 microseconds Inputs: 10 microseconds typical 500 microseconds worst case
RPM Calculation	14.65 milliseconds
I/O Image Table	5 milliseconds

---

**NOTE:** If the PLC's scan rate is slower than 5 milliseconds, then the actual I/O Image Table update to the user's application would be the scan rate of the PLC.

---

RPM:	Maximum RPM: $\pm 1,800$
Total Setpoints:	1024 (stitching setpoints each count as one setpoint)
Limit Switch Outputs:	Optically isolated driver Current sinking 5 VDC 30 mA (Typically used to drive relays on I/O module rack)
Auxiliary Inputs:	Sinking input (current source, sink to actuate) 5 VDC 15 mA (Typically actuated by input relays on I/O module rack)
Auxiliary Communications Port:	The auxiliary port is currently not available for customer use. Contact factory for special application.

---

## I/O Module Rack

DC Output Channel:	N.O., 3–60 VDC load voltage range 1.5 mA maximum off-state leakage at 60 VDC 0.02–3.0 amps load current range 20 $\mu$ Sec. maximum turn-on time 50 $\mu$ Sec. maximum turn-off time Part # 04523064, type 70M-ODC5
DC Input Channel:	3–32 VDC input voltage range 18 mA input current at maximum input voltage 0.20 mSec. maximum turn-on time 0.40 mSec. maximum turn-off time Part # 04523093, type 70M-IDC5
AC Output Channel:	N.O., zero crossing turn-on 0.03–3.0 amps load current range (rms) 2 mA maximum off-state linkage 8.3 mSec. maximum turn-on time (60 Hz) 8.3 mSec. maximum turn-off time (60 Hz) 24–140 VAC load voltage range Part # 04523063, type 70M-OAC5
AC Input Channel:	20 mSec. maximum turn-on time 20 mSec. maximum turn-off time 90–140 VAC input voltage range 8 mA input current at maximum input voltage Part # 04523094, type 70M-IAC5

# Glossary

<b>Fault Error</b>	An error usually caused from the resolver failing to operate properly or an error with the PLS's internal hardware. This type of error will cause the PLS to set the Fault bit (0) in the Status word (Status group). The exact cause of the error can be determined by reading the Fault Condition word (Status group).
<b>Input Detection Window</b>	A programmed window within which an input must occur in order to enable a special purpose output.
<b>Input Transition</b>	The point at which an input becomes energized or de-energized.
<b>Linear Speed Offset</b>	A function which allows output channels 1–16 to be individually programmed to advance and retard depending on the speed of the resolver. This function is used to compensate for the mechanical lag in glue guns and actuators that must be precisely synchronized with the position of a product moving through a process.
<b>Output Enabler Input</b>	Input channels on the I/O module rack that can be programmed to disable linked output channels if the inputs do not energize within their specified windows or when an input transition occurs (depending on what mode was chosen).
<b>Group</b>	A group of words having common uses. The following are the seven groups currently used on the PLS: Status, Configuration, Linear Speed Offset, Input Configuration, Setpoint Transfer, Command, and Fault History.
<b>Remote Setpoint Tuning Inputs</b>	Input channels on the I/O module rack that can be used to advance or retard a pre-selected group of up to 16 output channels from a remote location. Actuation of the advance input will move all setpoints on the selected output channels forward in a predefined (programmable) increment. Actuation of the retard input moves these same setpoints backward in a predefined (programmable) increment.
<b>Reset to Preset Inputs</b>	Input channels on the I/O module rack that can be programmed to reset linked output channels to a pre-

programmed resolver position when one of the inputs energizes. This function can be used to synchronize outputs with the leading edge of a product entering a workstation. This allows the outputs to accurately energize when products randomly enter the workstation.

**Standard Setpoint**

Data used to program an output channel to energize and de-energize at certain resolver positions.

**Stitching Setpoint**

Data used to program an output channel to energize and de-energize multiple times between specific resolver positions. A special programming sequence is provided that simplifies the programming of a stitching pattern output.

**Warning Error**

An error usually caused from the entry of an invalid parameter. This type of error will cause the PLS to set the Warning bit (1) in the Status word (Status group). The exact cause of the error can be determined by reading the Warning Condition word (Status group).



# Index

## B

## bits

- Fault (Status) 32
- Input 10 (Configuration) 39
- Input 9 (Configuration) 39
- Input Invert (Configuration) 39
- PLS Run Enable (Configuration) 39
- Processor Busy (Status) 32
- Running (Status) 32
- Valid File (Status) 32
- Warning (Status) 32

Block Transfer Read (BTR) Group Identifier  
40

## C

- Command group 52
- Command Parameters 1–5 words (Command)  
52
- Command word (Command) 52
- commands
  - Initialize 54
  - List Setpoints 55
  - Reset 54
  - Restore 55
  - Save 2, 54
  - Set Home 56
- Configuration group 38
- Current File CRC word (Status) 35
- Current File Number word (Status) 35
- Current Position word 35

## D

Data words (Setpoint Transfer) 51

## E

- Error Code words (Fault History) 53
- Error Time words (Fault History) 53

## F

Fault bit (Status) 32

- Fault Condition word (Status) 33
- Fault History group 53
- Firmware Version word (Status) 32
- Force Off LS16–LS1 word (Configuration)  
40
- Force Off LS32–LS17 word (Configuration)  
40
- Force On LS16–LS1 word (Configuration)  
39
- Force On LS32–LS17 word (Configuration)  
39

## G

## groups

- Command 52
- Configuration 38
- Fault History 53
- Input Configuration 46
- Linear Speed Offset 45
- Setpoint Transfer 49
- Status 32

## H

Hardware Version word (Status) 32

## I

- I/O Image Input Selection 1 and 2  
word 40
- I/O Image Output Selection 1 and 2  
word 41, 42
  - Initialize command 54
- Input 10 bit (Configuration) 39
- Input 9 bit (Configuration) 39
- Input Capture words (Status) 37
- Input Configuration group 46
- Input Invert bits (Configuration) 39
- Input State word 36
- Input Transition Map word (Status) 37
- Input Type words (Input Configuration) 47
- Input Warning Map word (Status) 37

**L**

Linear Speed Offset group 44  
Linear Speed Offset words 45  
List Setpoints command 55

**M**

Minimum RPM Disable word 43  
Mode Control word (Configuration) 38  
Motion Detect Channel Number word (Configuration) 43  
Motion Detect RPM Minimum word (Configuration) 43

**N**

Number of Extended Setpoints word (Setpoint Transfer) 50  
Number of Standard Setpoints words (Setpoint Transfer) 50

**O**

Output Channel word 45  
Output Link words 1–16 (Input Configuration) 48

**P**

Parameter words (Input Configuration) 49  
PLS Outputs LS16–LS1 (Status) 37  
PLS Outputs LS32–LS17 (Status) 36  
PLS Run Enable bit (Configuration) 39  
Processor Busy bit (Status) 32

**R**

Remote Setpoint Tune word (Status) 36  
Reset command 54  
Restore command 55  
RPM word (Status) 36  
Running bit (Status) 32

**S**

Save command 54  
Scale Factor word (Configuration) 42  
Set Home command 56

Set Speed Channels word (Configuration) 43  
Setpoint Command word (Setpoint Transfer) 50  
Setpoint Transfer group 49  
Status group 30  
Status word (Status) 32

**V**

Valid File bit (Status) 32

**W**

Warning bit (Status) 32  
Warning Condition word (Status) 34, 71  
words  
  Block Transfer Read (BTR) Group Identifier (Configuration) 40  
  Command (Command) 52  
  Command Parameters 1–5 (Command) 52  
  Current File CRC (Status) 35  
  Current File Number (Status) 35  
  Current Position 35  
  Data (Setpoint Transfer) 51  
  Error Code (Fault History) 54  
  Error Time (Fault History) 54  
  Fault Condition (Status) 33  
  Firmware Version (Status) 32  
  Force Off LS16–LS1 (Configuration) 40  
  Force Off LS32–LS17 (Configuration) 40  
  Force On LS16–LS1 (Configuration) 39  
  Force On LS32–LS17 (Configuration) 39  
  Hardware Version (Status) 32  
  I/O Image Input Selection 1 and 2 40  
  I/O Image Output Selection 1 and 2 41, 42  
  Input Capture (Status) 37  
  Input State 36  
  Input Transition Map (Status) 37  
  Input Type (Input Configuration) 46  
  Input Warning Map (Status) 37  
  Linear Speed Offset 44  
  Minimum RPM Disable 43  
  Mode Control 38  
  Motion Detect Channel Number (Configuration) 43

Motion Detect RPM Minimum (Configuration) 43  
Number of Extended Setpoints (Setpoint Transfer) 50  
Number of Standard Setpoints (Setpoint Transfer) 50  
Output Channel 45  
Output Link 1–16 (Input Configuration) 48  
Parameter (Input Configuration) 49  
PLS Outputs LS16–LS1 (Status) 37  
PLS Outputs LS32–LS17 (Status) 36  
Remote Setpoint Tune (Status) 36  
RPM (Status) 36  
Scale Factor (Configuration) 42  
Set Speed Channels (Configuration) 43  
Setpoint Command (Setpoint Transfer) 50  
Status (Status) 32  
Warning Condition (Status) 34, 71

**AMETEK<sup>®</sup>**  
**PATRIOT SENSORS**

AMETEK Patriot Sensors • 1080 N. Crooks Road • Clawson, MI 48017  
800-635-0289 • 248-435-0700 • Fax 248-435-8120 • [www.patriotsensors.com](http://www.patriotsensors.com)

1133  
1771.M1R  
4/99.Z33  
5C