

AMETEK[®]

Series 951
Gemco[™] Quik-Stik[™] II
Linear Displacement Transducer



Installation, Maintenance and Programming Manual



1080 North Crooks Road
Clawson, MI 48017-1097
Phone: (248) 435-0700
FAX: (248) 435-8120
Internet: www.ametek.com www.ametekapt.com

Preface

This manual is divided into three parts. Part 1 provides instructions for the electrician on how to install and maintain the Series 951 Linear Displacement Transducer (LDT). This includes wiring the LDT to a power supply, an external device for monitoring or control, and/or an interface device for programming. Part 2 provides programming procedures and reference material for the programmer. This is necessary when the LDT is connected to an interface device, such as a PC or a hand-held programmer. Finally, Part 3 contains three appendixes: Troubleshooting, Command Summary, and Specifications. To further assist you in this manual, a glossary is also provided at the back.

Copyright 2001 by AMETEK Automation & Process Technologies
All Rights Reserved - Made in the U.S.A.
Version 0.1

AMETEK has checked the accuracy of this manual at the time it was printed. Any comments you may have for the improvement of this manual are welcomed.

AMETEK reserves the right to revise and redistribute the entire contents or selected pages of this manual. All rights to the contents of this manual are reserved by AMETEK.

Chapter 1: Hardware Overview	1
1.1 Model Number Code for Analog LDTs	3
1.2 Model Number Code for Digital LDTs	4
Chapter 2: Installing the LDT	6
2.1 Installing the LDT to a Mounting Bracket	6
2.2 Installing the LDT to a Hydraulic Cylinder	8
Chapter 3: Wiring Connections	11
3.1 951A-V (Voltage)	11
3.2 951A-C1/C2 (Current)	12
3.3 951CP (Controlled Pulse)	16
3.4 951VP (Variable Pulse)	18
3.5 951RS/TP (Start/Stop)	20
3.6 Communications Connections	23
3.7 Connections to an Interface Device	23
3.8 Hand-held Programmer as Your Interface Device	24
3.9 Dumb Terminal or PC as Your Interface Device	24
Chapter 4: Programming	26
4.1 Devices Used to Program the LDT	27
4.2 Programming through a PC or Dumb Terminal	27
4.3 Programming through the Hand-held Programmer	27
4.4 Analog Program Commands Defined	28
4.5 Digital Program Commands Defined	39
Appendix A: Troubleshooting	49
Appendix B: Command Summary	52
Appendix C: Specifications	54
Glossary	57

Chapter 1: Hardware Overview

The Gemco Series 951 QUIK-STIK II™ is a line of magnetostrictive linear displacement transducers (LDT). Each LDT offers highly accurate position and optional velocity sensing. The LDT also is built to withstand the most severe environment conditions. The cornerstone to this new style of LDT is its patented sensing and temperature compensating techniques. The LDT is completely absolute. Power loss will not cause the unit to lose positional information or require re-zeroing. Also, the non-contact design allows this device to be used in highly repetitive applications without mechanical wear.

NOTE: There are a variety of different types of LDT's that the factory offers. The model number on you LDT is a record of all the specific characteristics that make up your unit. This includes what type it is: analog or digital; its output signal and range; stroke, null, and dead band length; and type of connector the unit uses. For a translation of the model number, see pages 3 and 4.

The following is a list of several unique features the QUIK-STIK II provides:

- Each QUIK-STIK II LDT requires a single-ended power supply. This eliminates the need for a dual-ended power supply.
- Analog LDTs are completely field programmable for zero reference, span, voltage type, and polarity. Digital LDTs are programmable for the number of recirculations, wire speed, internal or external interrogation, and change of mode (i.e. controlled pulse to variable pulse, etc.).
- Programming is accomplished through an RS-232 data link. This eliminates the need for removing the LDT's head cover which would expose the device's electronics to potential hazards.
- Programming interface can be accomplished through a dumb terminal or a PC with a terminal emulator software package, including PROCOMM PLUS® or Terminal for Windows™. A portable hand-held programmer is also available from the factory.

- The LDT's serial port can supply position information directly to computers not set up for analog or digital inputs. Custom programming and/or protocols are available.
- The onboard microprocessor makes the QUIK-STIK II LDT the most versatile system available on the market.

1.2: Model Number Code for Digital LDTs

951CP - 0120 - X - X - E

QUIK-STIK II LDT

CP = Controlled Pulse
VP = Variable Pulse
RS = RS422 Start/Stop Pulse with Interrogation
TP = Start/Stop Pulse

Stroke

Insert stroke in inches to .1". Enter as a four-place number. For example, 12.0" = 0120.
Millimeter measurements do not contain a decimal and are followed by the letter "M". For Example, 12 mm = 0012M

Null

Null Dimension
X = Standard 1.5 inch Null
N□ = Insert non-standard Null over 1.5 inches
(Add non-standard portion of Null length to stroke length to calculate list price)

Dead Band

X = Standard Dead Zone of 2.25 inches
D□ = Insert non-standard Dead Zone over 2.25 inches
(Add non-standard portion of Dead Zone length to stroke length to calculate list price)

Connector

E = Environmental MS Connector*
C□ = Potted Pigtail Cable Assembly. Insert pigtail length in feet.
T = Threaded Metal Connector (fits MTS® - "RB" on Tempo II™ or III)
Q = Bayonet Style Connector (fits MTS® - "RC" on Tempo II™ or III)
M = 1/4 Turn Quick Disconnect (fits MTS® - "MS" on Tempo II™ or III)

*If option E (Environmental Connector) is selected, mating connector and/or pigtail must be ordered separately.

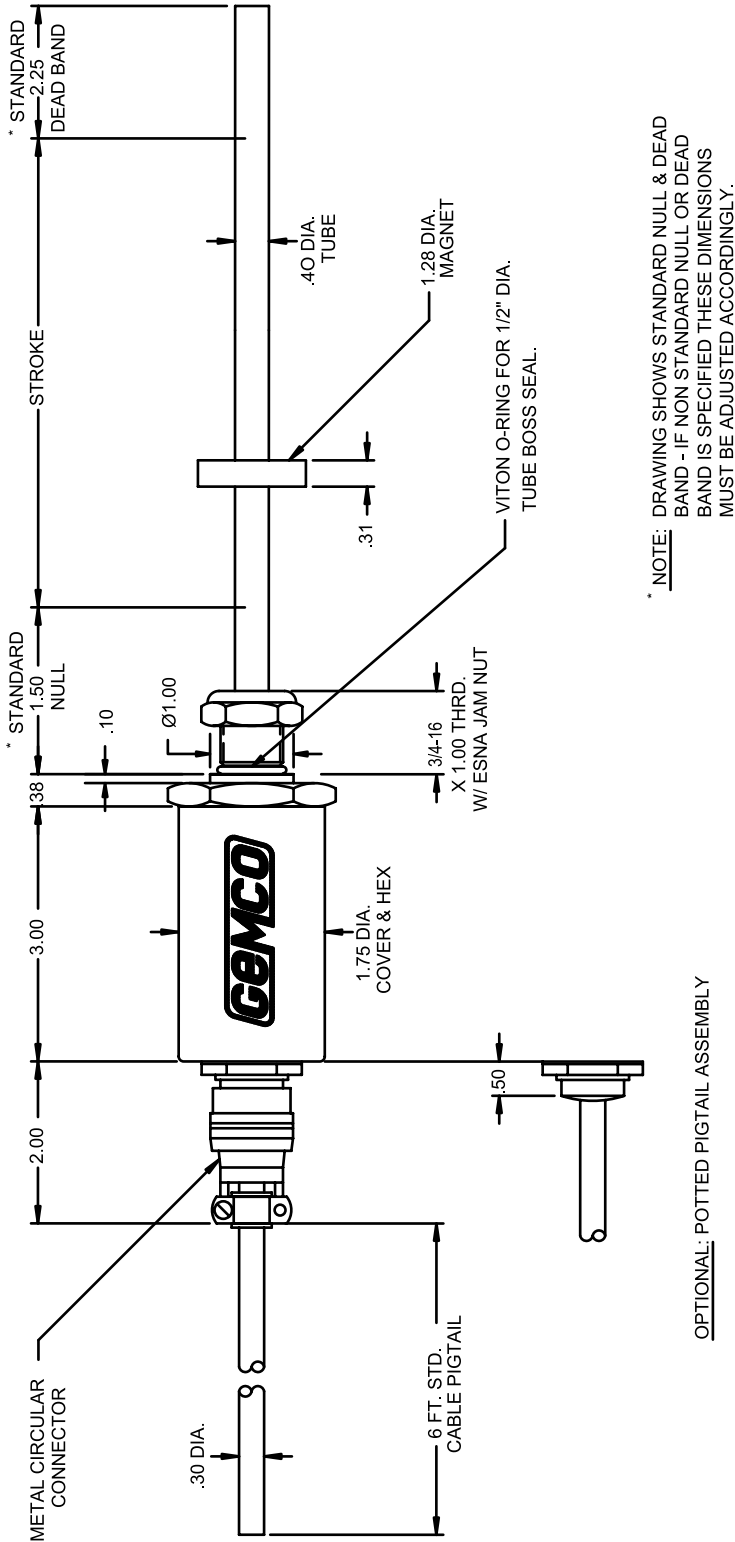

Figure 1-1 Series 951 Linear Displacement Transducer

Chapter 2: Installing the LDT

Before installing the LDT, you should consider the following:

- If you are using mounting brackets made of a ferromagnetic material (a material readily magnetized), they should be placed no closer than 0.25" into the area of the device's guide rail.
- To minimize the effects of magnetic flux distortion (which could cause an inaccurate measurement of the magnet's position), ferromagnetic material should not be placed closer than 0.25" from the magnet.

2.1: Installing the LDT to a Mounting Bracket

Perform the following steps to install your LDT to a mounting bracket. To assist you in finding the position of parts that are discussed in this section, refer to Figure 1-1. If you are installing your LDT into a hydraulic cylinder, refer to Section 2.2 Installing the LDT into a Hydraulic Cylinder.

1. Unscrew the LDT's jam nut from the threads protruding from the hex mounting base.
2. Insert the LDT's guide rail into the mounting bracket's hole.

Your mounting bracket may contain a 3/4 - 16 UNF - 2B threaded hole. In this case, you will need to screw the LDT into this hole using the threads protruding from the hex mounting base.

3. Once the LDT is in place, screw the jam nut back onto the threads of the hex mounting base. Use the 1.75" hex mounting base on the head assembly to tighten the LDT within the bracket.

WARNING: Do not use the head assembly casing to tighten the LDT within the bracket. This may damage the LDT and will void your warranty

If the length of your LDT's guide rail is less than 30", ship to the sub-section: Mounting the Magnet Assembly.

Installing Support Brackets

It is recommended that a support bracket be used with LDTs having a guide rail 30" - 71" in length. Supporting the end of the guide rail will minimize operational errors and protect against damage due to shock and vibration. If the length of your LDT's guide rail is 72" or longer, it is recommended that you use additional support brackets. These additional support brackets must be made of a non-magnetic material. Because these additional support brackets will interfere with the magnet's movement, a special split-type magnet assembly (part number SD0411200) must be used. To order a split magnet and support brackets (part number SD0411100), contact factory.

To install a support bracket for a LDT having a guide rail 30" - 71" in length, perform step 4a. If your guide rail is longer than 71", perform step 4b.

- 4a. If the support bracket is made of a ferromagnetic material (material readily magnetized), install the support bracket no closer than 0.25" from where the guide rail's dead band ends and the area of stroke begins. Continue to the subsection: Mounting the Magnet Assembly.

Install two or more support brackets for an LDT having a guide rail of 72" or longer in length, perform the following steps:

- 4b. Install support brackets at increments of 48" throughout the LDT's guide rail. Support brackets placed within the null zone and area of stroke or closer than 0.25" to the beginning of these areas must be made of a non-magnetic material.

Mounting the Magnet Assembly

Before mounting the magnet assembly, you should consider the following:

- Ferromagnetic material should not be placed closer than 0.25" from the LDT's magnet assembly or guide rail. Failure to do so could cause magnetic flux distortion which would lead to erratic operations of the magnet's position. Materials with non-magnetic properties, such as brass, copper, aluminum, non-magnetic stainless steel, or plastics, can be in direct contact with the magnetic assembly and guide rail without producing any adverse results.

- Minimal clearance between the LDT's guide rail and the magnet assembly is required. Stress between the magnet and the guide rail can cause flexing of the mounting brackets. This can cause the appearance of excessive hysteresis.
- LDTs using a split magnet assembly must keep the diameter of the magnet assembly within the guide rail throughout the complete stroke. The diameter of this magnet assembly should not be farther than 0.2" away from the guide rail. Split magnet assemblies outside this range will cause signal loss.

To install the magnet assembly, perform the following steps:

1. Slide the magnet assembly over the LDT guide rail.
2. Mount the magnet to the non-magnetic, movable portion of the device being controlled using non-magnetic screws.

2.2: Installing the LDT to a Hydraulic Cylinder

Before mounting an LDT within a hydraulic cylinder, note the following considerations. Also, to assist you in finding the positions of parts that are discussed in this section, refer to figures 1-1 and 2-1.

- A non-magnetic spacer must be used to separate the magnet assembly from the head of the piston rod. See Figure 2-1.
- The magnet should not be closer than 1.5" from the base of the LDT's hex head when the piston rod is fully retracted. In instances where space restraints exist, it may be required to countersink the magnet into the piston rod. Two magnets are available for mounting to the piston rod: the standard 1.29" (in diameter, part number SD0400800) four-hole magnet and a 1.0" magnet (part number SD0410300) designed exclusively for countersunk mounting applications. The 1.0" magnet must be held captive with a snap ring.
- An O-ring groove is provided at the base of the LDT's mounting hex for pressure sealing. The O-ring seal was designed to meet Mil-Std-MS33656. Refer to SAE J514 for machining of mating surfaces.

- It is recommended that a chamfered rod bushing be used with LDTs having a guide rail 60.0" or longer in length. On applications with guide rails of this length, a chamfered rod bushing in front of the magnet may be required. This bushing will prevent wear to the aluminum material of the magnet assembly (wear occurs as the piston rod retracts from extended lengths). This rod bushing should be manufactured from a high wear polymer, such as Teflon®.
- It is recommended the bore for the cylinder piston rod have an outside diameter of at least 0.50". It is also recommended that the LDT guide rail and end of guide rail have an outside diameter of at least 0.40". Use standard practices for machining and mounting these components. Consult the cylinder manufacturer for details on applicable SAE or military specifications.

Before performing the following steps for installing the LDT into a hydraulic cylinder, you may need to perform machining and mounting tasks on your hydraulic cylinder. Consult the information and specifications provided by the cylinder manufacturer before beginning the following steps:

1. Unscrew the LDT's jam nut from the threads protruding from the hex mounting base.
2. Position the non-magnetic spacer against the piston face, followed by the magnet and, finally, the chamfered rod bushing. (If the length of the LDT's guide rail is 60.0" or longer in length, it is recommended that you use a chamfered rod bushing).
3. Insert non-magnetic screws through the chamfered rod bushing (if used), magnet, and non-magnetic spacer, and secure items by tightening screws.

If the leading edge of the magnet will come closer than 1.5" from the base of the LDT's hex head when the piston rod is fully retracted, you will need to countersink the magnet assembly into the piston rod. Both the standard 1.29" four-hole magnet assembly (part number SD0400800) and the 1.0" magnet assembly (part number SD0410300) are designed exclusively for countersinking mounting applications. If you have a 1.0" magnet assembly, you must use a snap ring to hold it in place, since no mounting holes are in this magnet.

4. Insert the LDT's guide rail into the hole of the hydraulic cylinder's mounting bracket.

You may need to remove a protective covering for the hydraulic cylinder before inserting the LDT. Also, the mounting bracket may contain a 3/4-16 UNF - 2B threaded hole. In this case, you will need to screw the LDT into this hole using the threads protruding from the LDT's hex mounting base.

WARNING: Do not use the casing of the head assembly or cable nuts (either a 1 1/6" or 1 3/16" cable nut) to tighten the LDT within the bracket (see Figure 2-1). This may damage the LDT and will void your warranty.

At this point, your LDT should now be properly installed inside the hydraulic cylinder. You now may need to assemble parts of the hydraulic cylinder. For assistance in this task, refer to the information provided by the cylinder manufacturer.

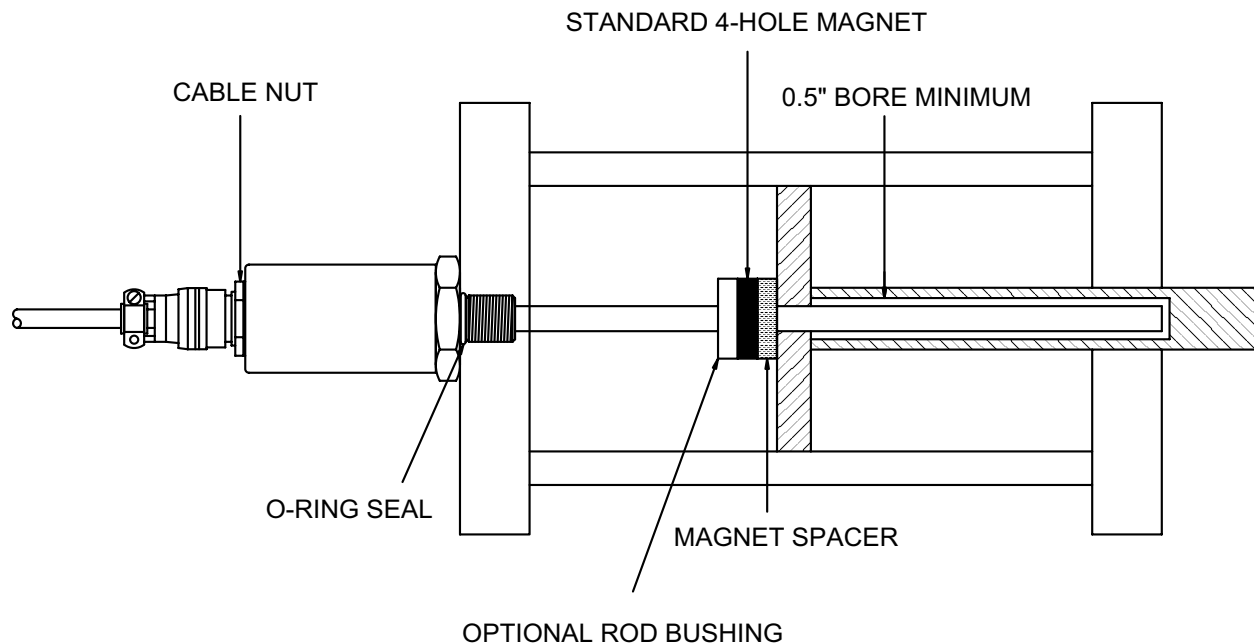

Figure 2-1 Mounting LDT in Hydraulic Cylinder

Chapter 3: Wiring Connections

Once the LDT has been installed, wiring connections can be made. There are two groups of connections you will need to make, with a third group of connections that is optional. They are as follows:

- Power Supply Connections (including grounding and shielding)
- LDT Output Connections
- Communications Connections (optional)

NOTE: When grounding the LDT, a single earth ground should be connected to the power supply common (circuit ground). The LDT power supply common (pin B) should be connected to the power supply common (-) terminal. Pin C should be connected to the power supply positive terminal (+). The LDT cable shield should be tied to earth ground at the power supply. The LDT analog common as well as the RS-232 common should not be connected to earth ground and should be used for connection to interface devices only. For assistance, refer to your LDT's wiring drawing in this chapter.

3.1: 951A-V (Voltage)

The 951A-V LDT generates a voltage output based on position. A voltage output based on velocity is optional. (Contact factory if you require a velocity.) The voltage value of the velocity output will reflect the same voltage levels as the position output. To understand how position and velocity outputs are determined for a LDT based on voltage, see Figure 3-1. The parameters contained in this figure are used only as examples. These parameters are fully programmable. To reconfigure these parameters, see Chapter 4: Programming. Further, note that velocity is typically ordered from the factory. However, LDTs ordered without velocity can be field configured for velocity output. This is done through velocity setup software that can be provided by the factory.

Both outputs based on position and velocity are referenced to the analog common terminal and should not be referenced to any of the other common terminals. To wire the 951A-V LDT, see Figure 3-4. For proper grounding information, see note at the beginning of this chapter.

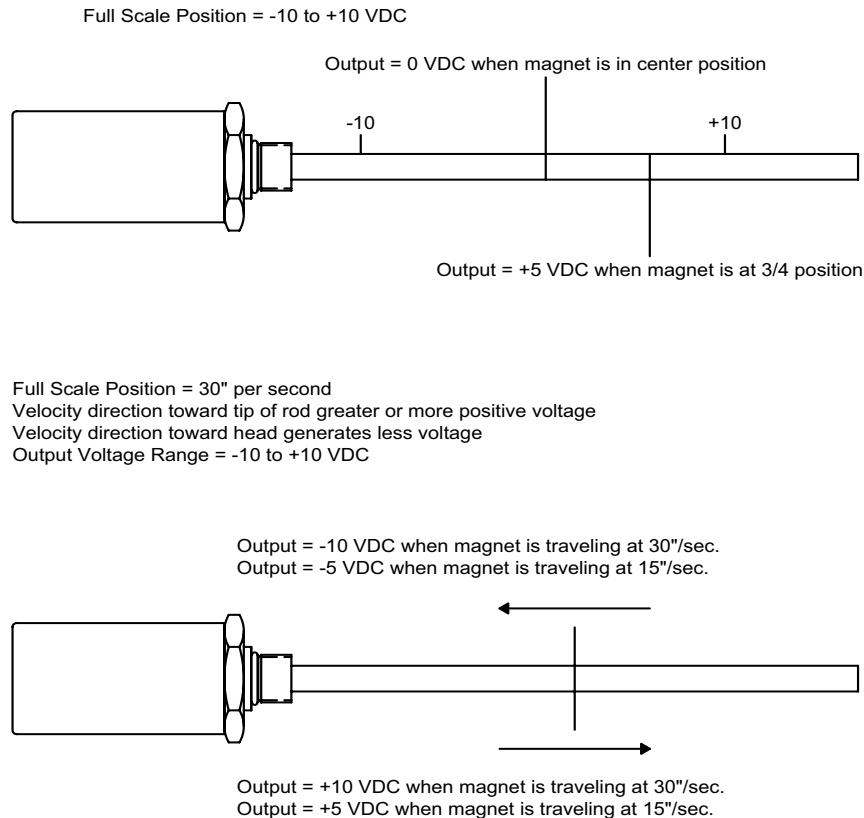
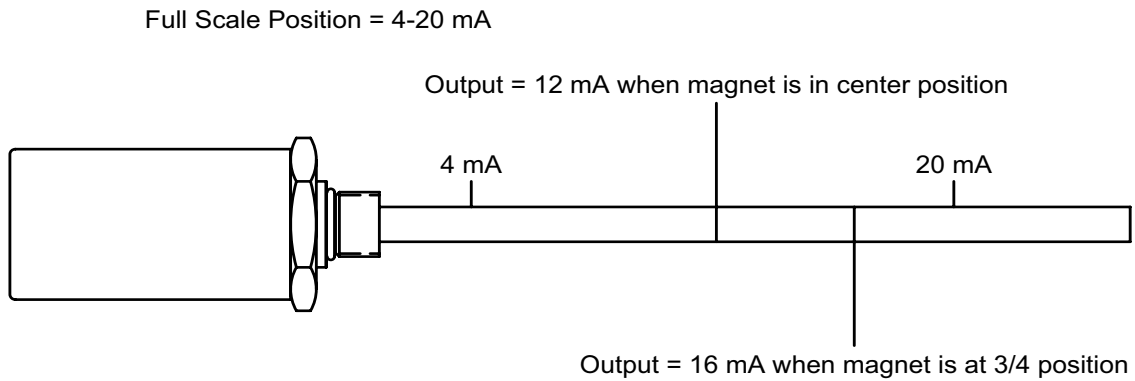

Figure 3-1 Examples of Position and Velocity Outputs for the 951A-V

3.2: 951A-C1/C2 (Current)

The 951A-C1/C2 LDT generates a current output based on position. A current output based on velocity is optional. (Contact factory if you require velocity). The current value of the velocity output will reflect the same current levels as the position output. To understand how position and velocity outputs are determined for an LDT based on current, see Figure 3-2. The parameters contained in this figure are used only as examples. These parameters are fully programmable. To reconfigure these parameters, see Chapter 4: Programming. Further, note that velocity is typically ordered from the factory. However, LDT's ordered without velocity can be field configured for velocity output. This is done through velocity setup software that can be provided by factory.

Both outputs based on position and velocity are referenced to the analog common terminal and should not be referenced to any of the other common terminals. Note that the grounded style (standard) LDT sources the 4 to 20 mA while the ungrounded style unit sinks the 4 to 20 mA. To wire the 951A-C1/C2 LDT, see Figure 3-4. For proper grounding information, see note at the beginning of this chapter.



Full Scale Position = 30" per second
 Velocity direction toward tip of rod generates greater current
 Velocity direction toward head generates less current
 Output Voltage Range = 4-20 mA

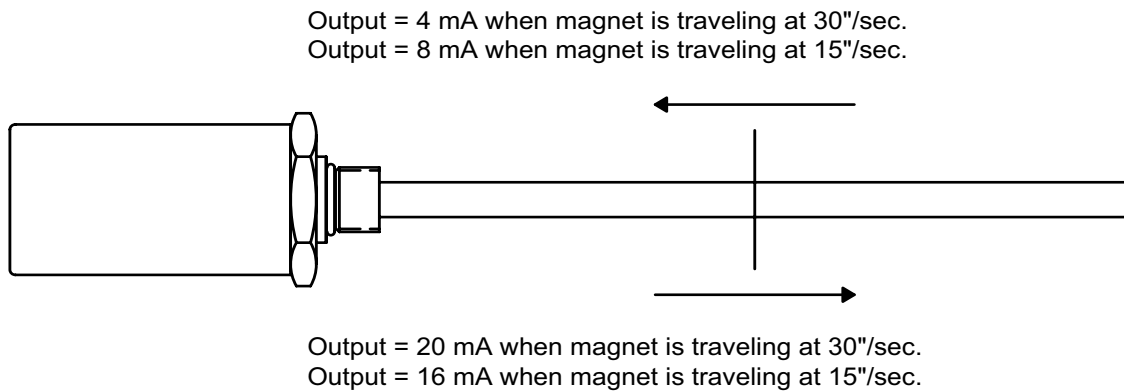
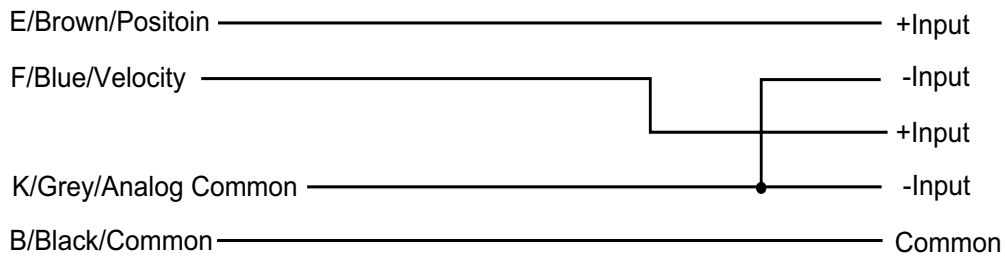
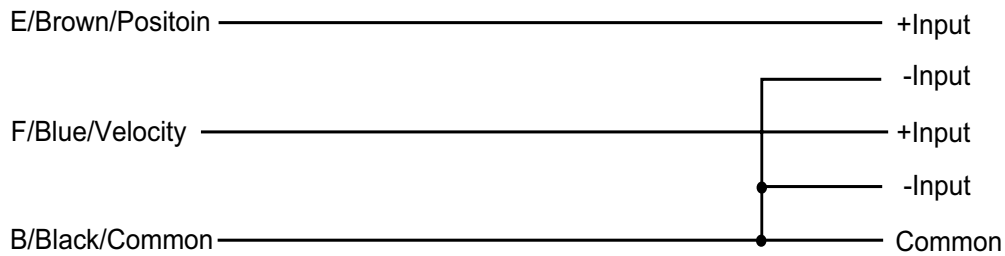

Figure 3-2 Examples of Position and Velocity Outputs for the 951A-C

Grounded System



-or-



Ungrounded System

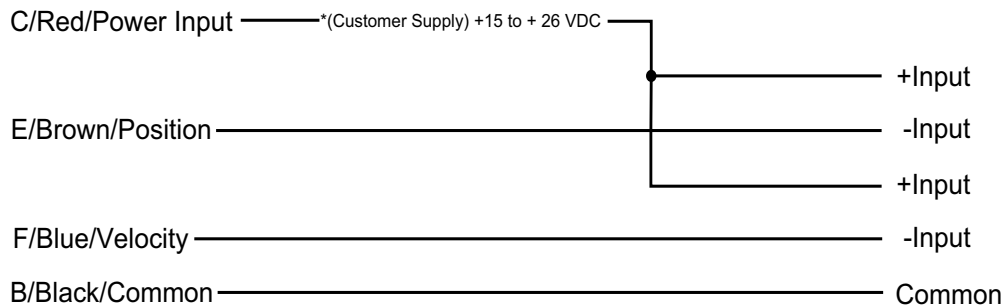

*Customer power supply can feed both the LDT and the customer input card.

* NOTE: LDT sinks 4 to 20mA.

Figure 3-3 Current Sourcing and Sinking

NOTE: 951A-C1 is for current sourcing which allows the current to flow from the LDT into the user's equipment. 951A-C2 is for current sinking which allows the current to flow from the user's equipment into the LDT. Because higher currents can come from the user's equipment, which can cause damage to the LDT, current sourcing is the more recommended method for current flow. See Figure 3-3.

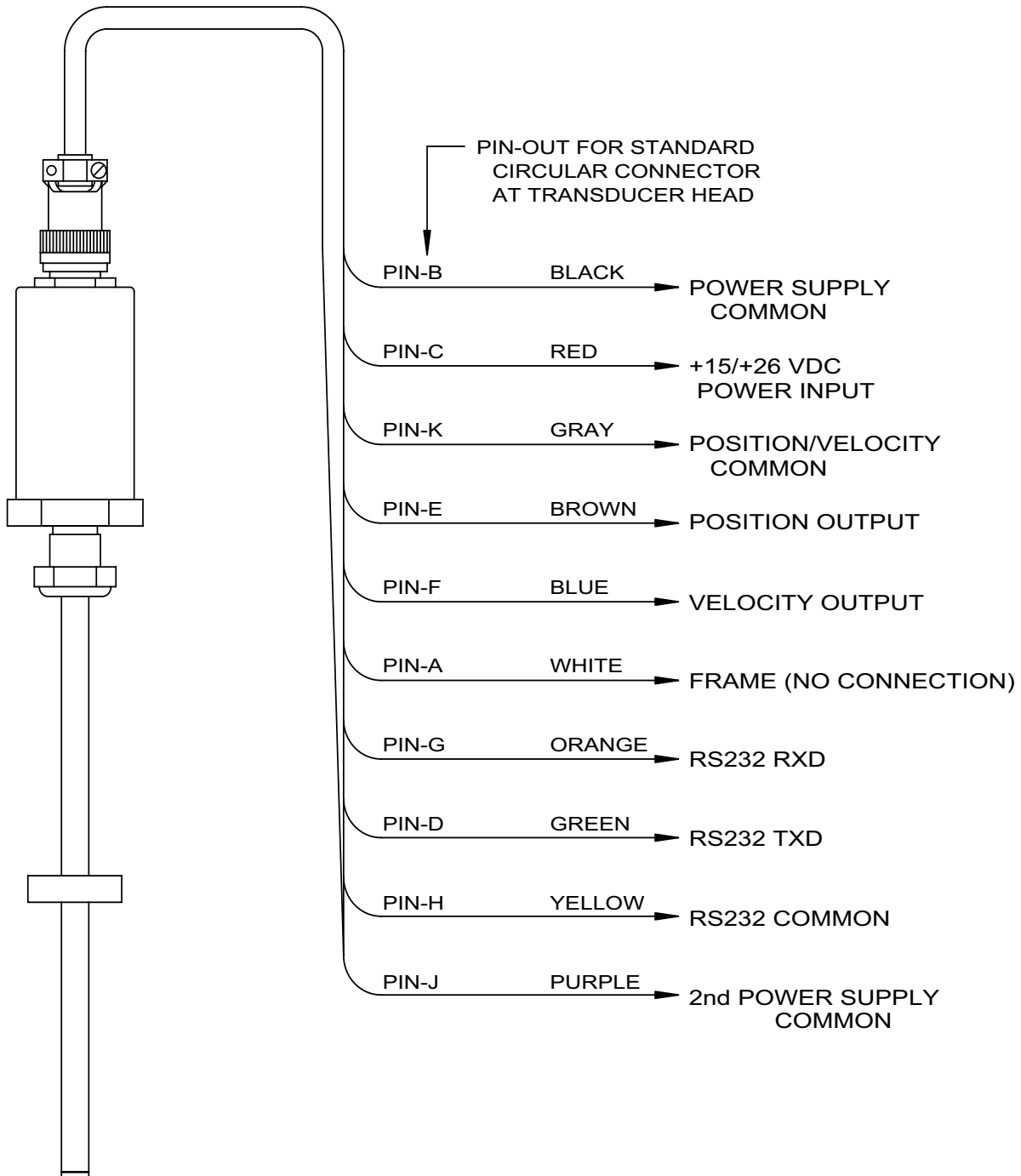

Figure 3-4 Analog Wiring Drawing
Drawing E0213900

3.3: 951CP (Controlled Pulse)

The 951CP can be configured to generate digital outputs, and can be used with its RS-422 standard or the positive RS-422 output can be used as a single-wire, 5-volt output. To initiate a start pulse, an external device is used. This start pulse must be a minimum of 0.2 microseconds in width. After the start pulse is generated, the LDT will generate a stop pulse of 1.0 microsecond in width. The time between the leading edge of the start pulse to the leading edge of the stop pulse is the proportional distance between the magnet to the hex head. The order of these two pulses is illustrated in Figure 3-5. To wire the 951CP, see Figure 3-6. For proper grounding information, see note at the beginning of this chapter.

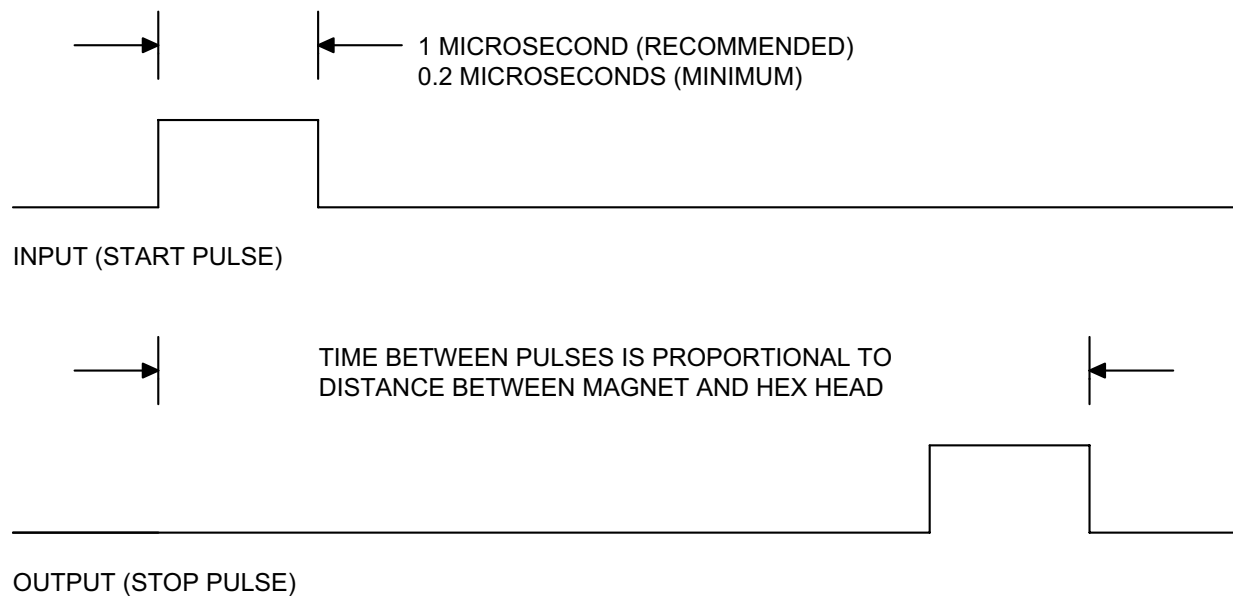

Figure 3-5 951CP Start and Stop Pulses

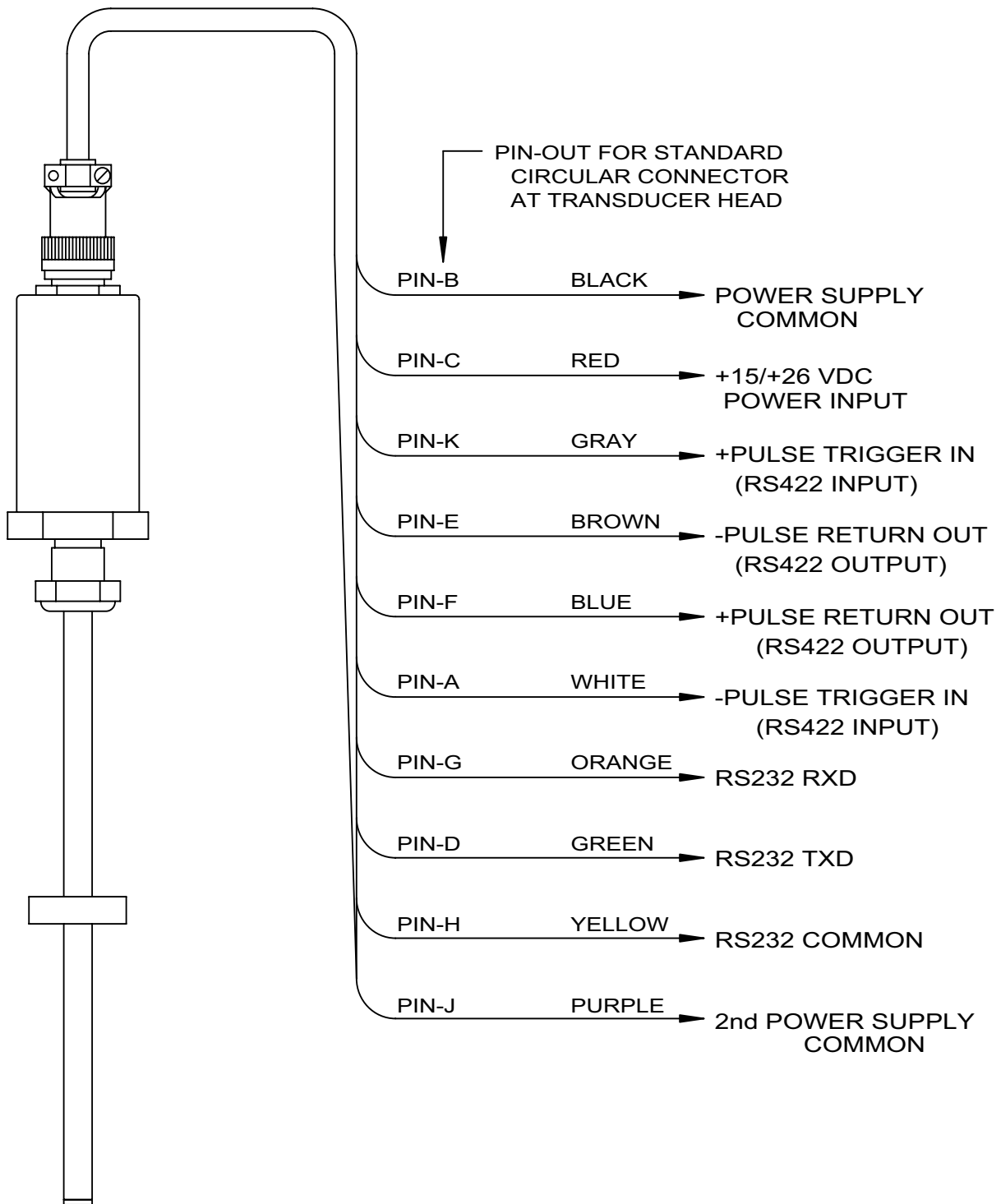

Figure 3-6 951CP with RS-422 Wiring Drawing
Drawing E0213901

3.4: 951VP (Variable Pulse)

The 951VP can be configured to generate digital outputs, and can be used with its RS-422 standard or the positive RS-422 output can be used as a single-wire, 5-volt output. This LDT can also be configured to generate external or internal interrogation. External interrogation is when an external device connected to the LDT generates a start pulse. This start pulse must be a minimum of 0.2 microseconds in width. Within 2.0 microseconds after the start pulse has been generated, the LDT will generate a stop pulse. The width of the stop pulse is proportional to the distance from the magnet to the hex head. The order of these two pulses is illustrated in Figure 3-7. The 951VP can also generate internal interrogations. This LDT will continually send stop pulses. As with a 951VP using an external interrogation, the width of this stop pulse is proportional to the distance from the magnet to the hex head. This is illustrated in Figure 3-8. For wiring the 951VP, see Figure 3-9. For proper grounding information, see note at the beginning of this chapter.

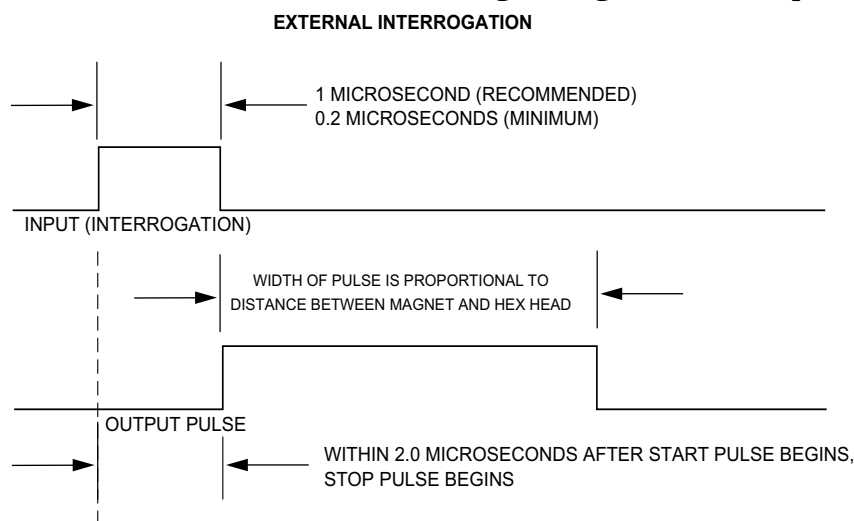

Figure 3-7 951VP with External Interrogation

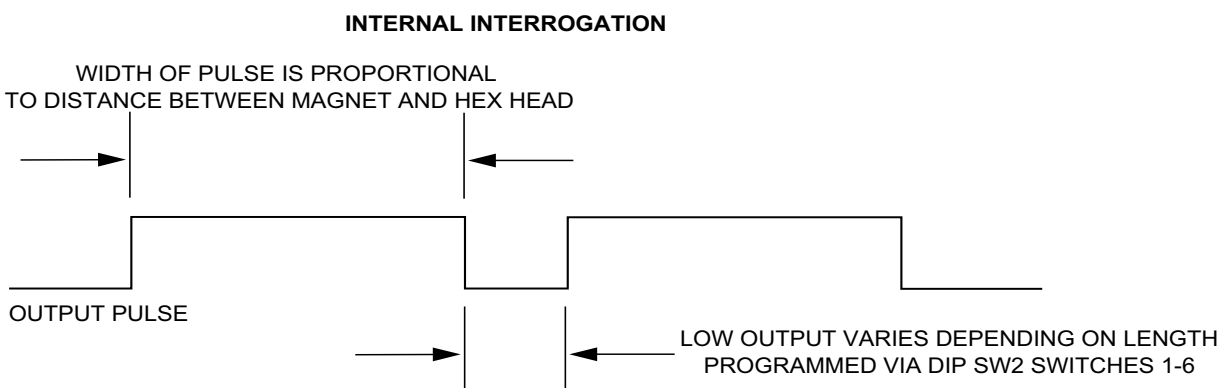

Figure 3-8 951VP with Internal Interrogation

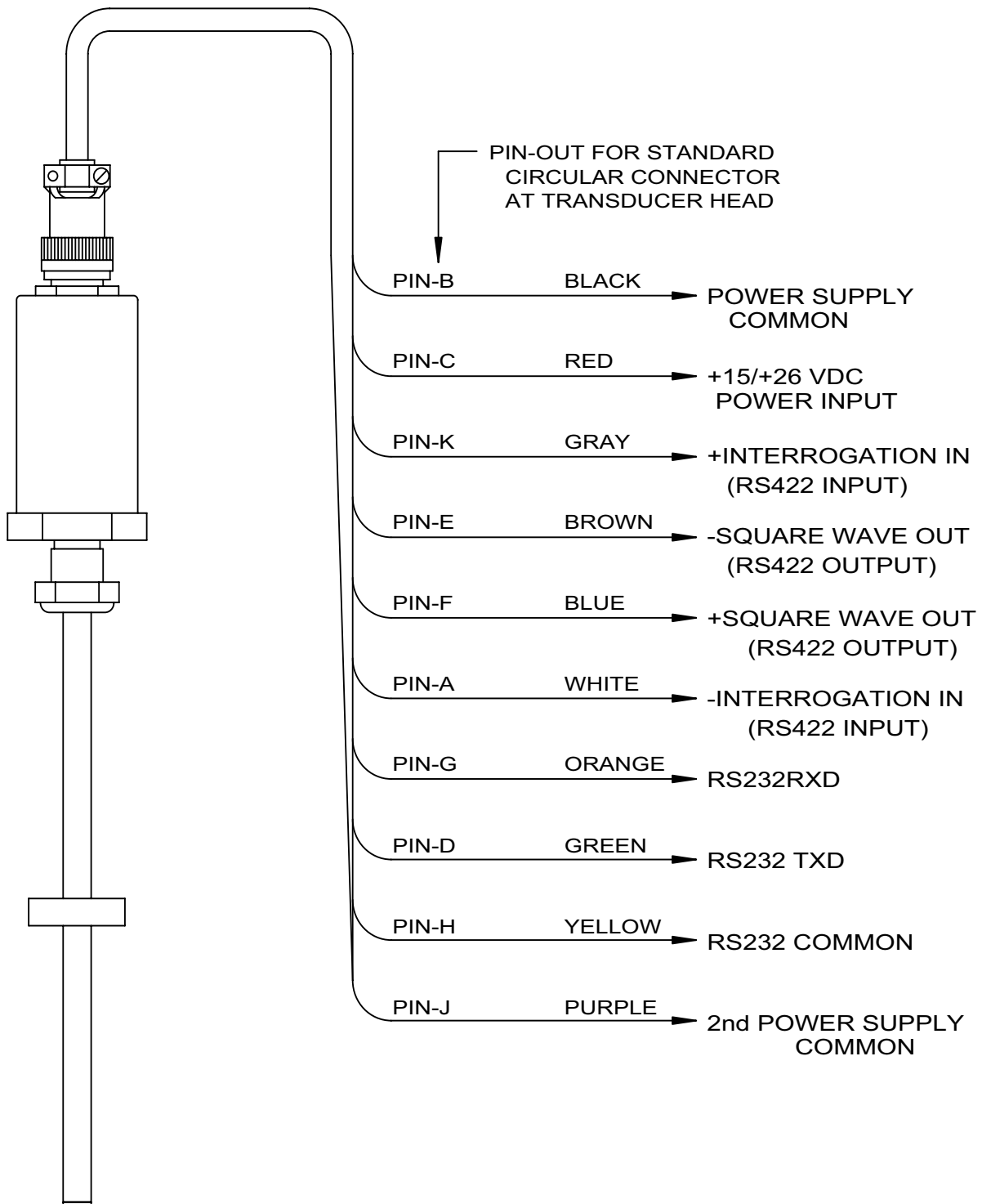

Figure 3-9 951VP with RS-422 Wiring Drawing
Drawing E0213902

3.5: 951RS/TP (Start/Stop)

The 951RS/TP with interrogation can be configured to generate digital outputs, and can be used with its RS-422 standard or the positive RS-422 output can be used as a single-wire, 5-volt output. To initiate a start pulse, an external device is used. This start pulse must be a minimum of 0.2 microseconds in width. Within 2.0 microseconds after the start pulse begins, the LDT will generate a start pulse of 1.0 microsecond in width. A stop pulse of 1.0 microsecond in width will follow. The time it takes from the leading edge of the start pulse to the leading edge of the stop pulse is the proportional distance between the magnet to the hex head. The order of these two pulses is illustrated in Figure 3-10. To wire the 951RS, see Figure 3-11. To wire the 951TP, see Figure 3-12. For proper grounding information, see note at the beginning of this chapter.

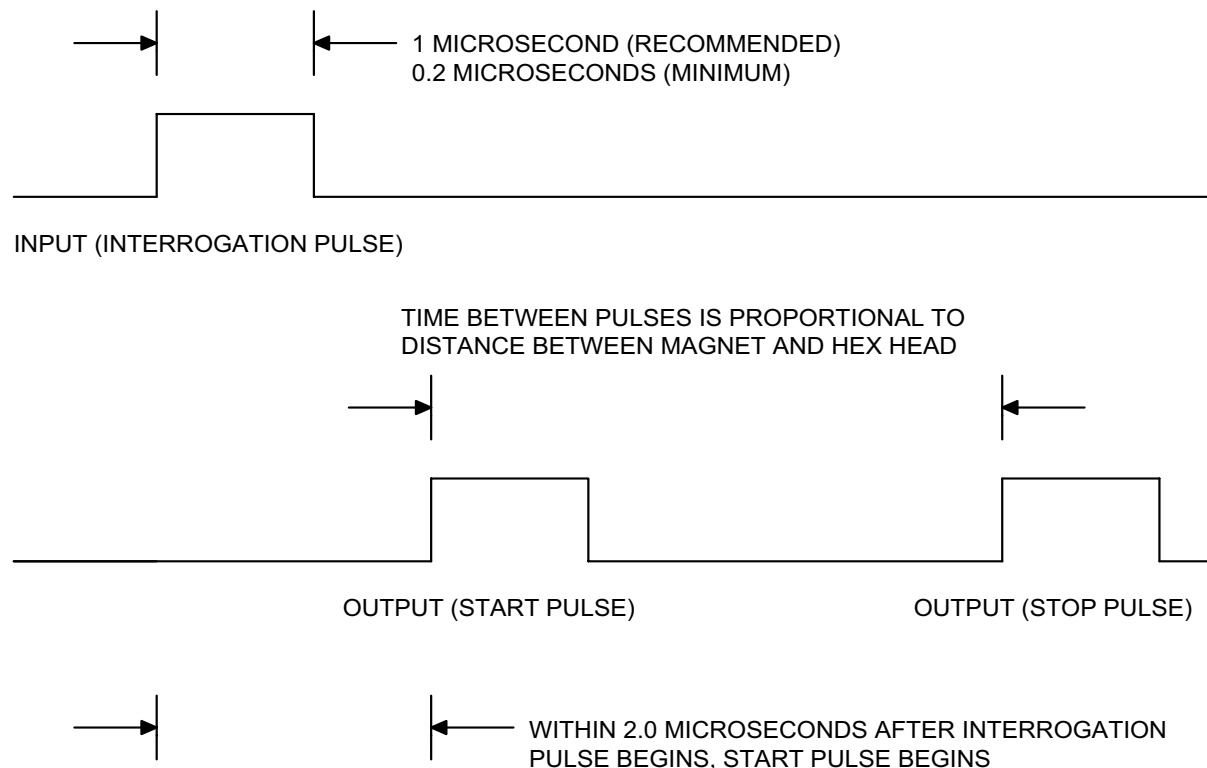

Figure 3-10 951RS/TP Pulses

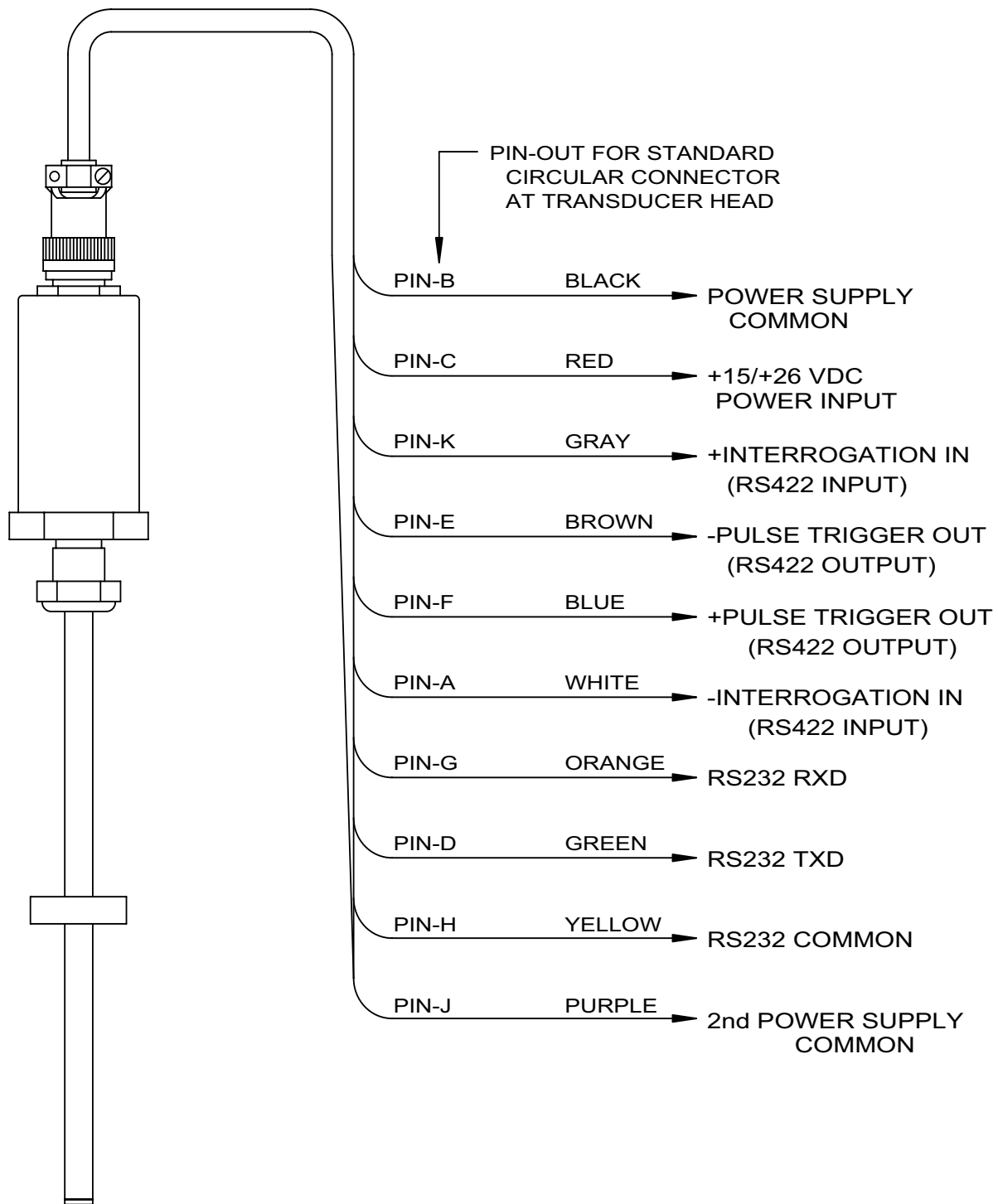

Figure 3-11 951RS Wiring Drawing
Drawing E0213903

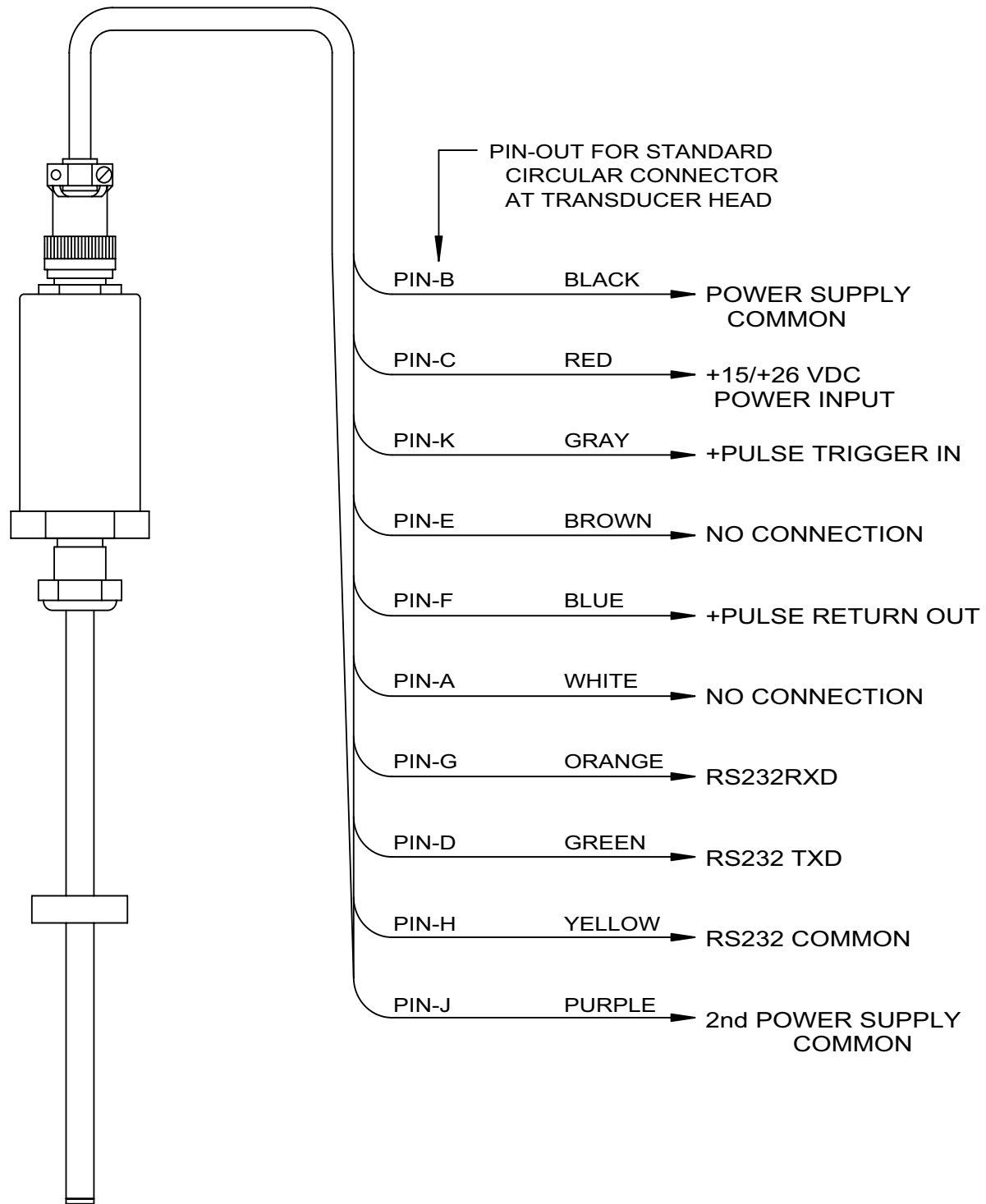

Figure 3-12 951TP Wiring Drawing
Drawing E0213904

3.6: Communications Connections

Communications connections are optional. These connections are made if you want to have a host computer or factory's hand-held programmer interface with the LDT. Regardless of which LDT you have installed, connections for interfacing are the same. This consists of connecting three wires from the LDT's cable to three terminals in the modular jack. Using an RJ11 modular jack is suggested so that connections between a computer or the hand-held programmer can be made quickly. This is because the hand-held programmer has an RJ11 modular cable, as shown in Figure 3-14. To make these connections, see the figures in this section as well as your LDT's wiring drawing at the beginning of Chapter 3.

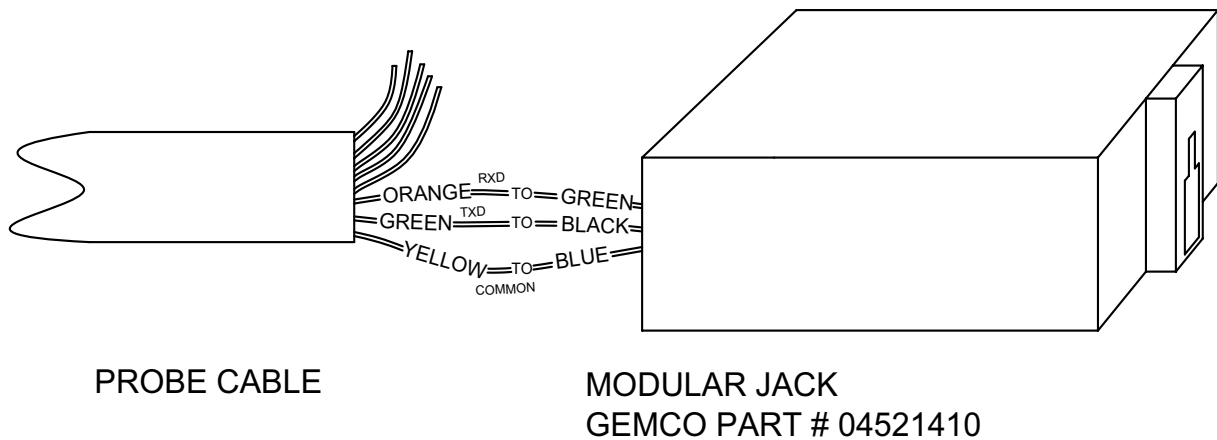

Figure 3-13 Connecting LDT Cable to a Modular Jack

3.7: Connections to an Interface Device

After connecting the communications wires from the LDT's cable to the RJ11 modular jack, you are now ready to make connections to the interface device. There are three types of devices that can be used to interface with the LDT: a dumb terminal, a personal computer having a terminal emulation software package, and Ametek's hand-held programmer.

3.8: Hand-held Programmer as Your Interface Device

It is easy to connect the hand-held programmer to the LDT. Once the LDT's communications wires are connected to an RJ11 modular jack, the user can simply plug the programmer's cable into the modular jack, as shown in Figure 3-14.

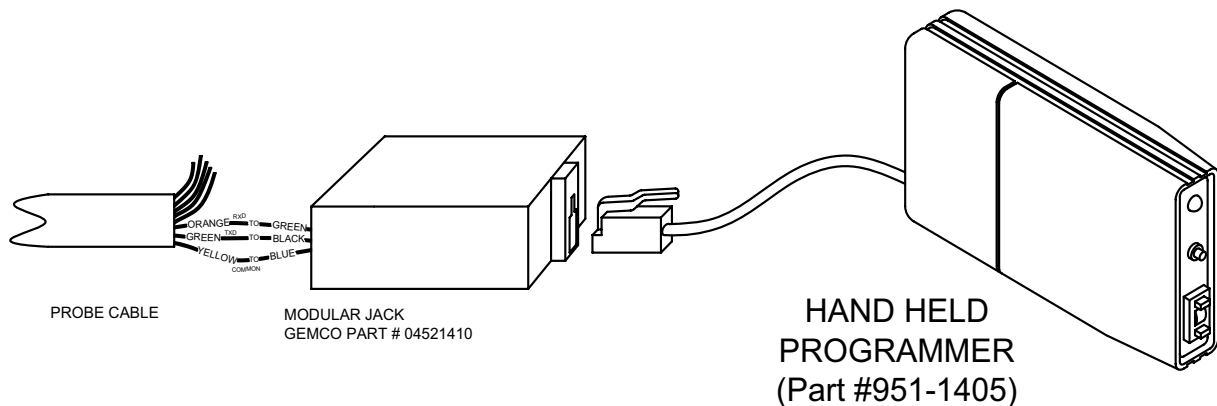
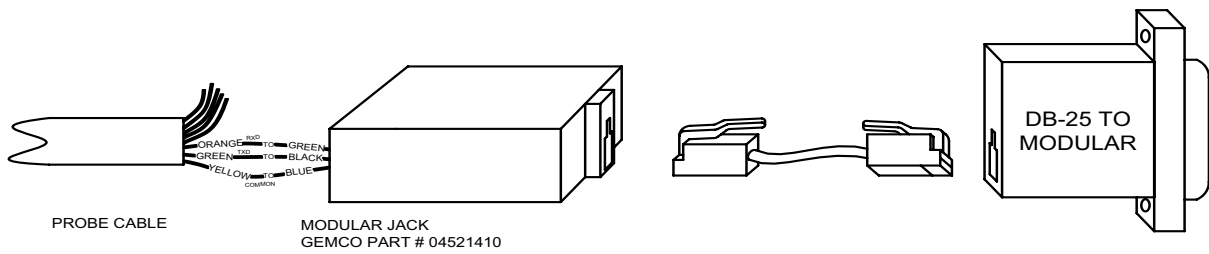

Figure 3-14 Factory's Gemco brand Hand-held Programmer

3.9: Dumb Terminal or PC as Your Interface Device

You can use a dumb terminal or personal computer (PC) to interface with the LDT. If you use a PC, you will need a terminal emulation software package. There are many types of terminal emulation software packages on the market, such as PROCOMM PLUS[®] or Terminal for Windows[™].

When connecting a dumb terminal or PC to the LDT, it is recommended that you use an RJ11 modular jack for your initial connections, as shown in Figure 3-13. After these connections are made, you can simply connect a standard terminated cable to the modular jack and to a modular adapter, as shown in Figure 3-15. A DB-9 or DB-25 adapter can be used, depending on what serial port is available on your PC or terminal. Contact Factory for part numbers for kits illustrated in Figure 3-15.



TYPICAL MODULAR RS-232 CONNECTIONS FROM PROBE TO DB-25

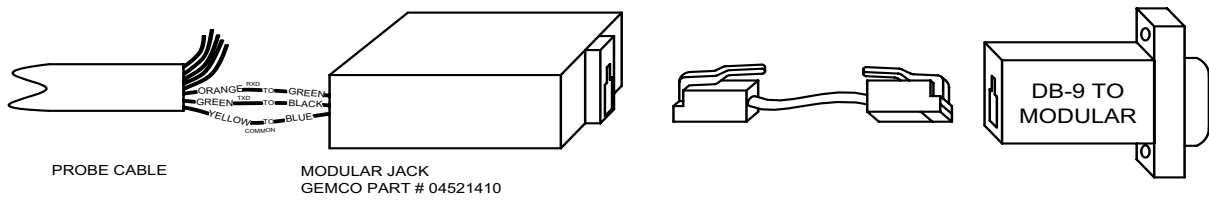

TYPICAL MODULAR RS-232 CONNECTIONS FROM PROBE TO DB-9

Figure 3-15 DB-9 and DB-25 Adapter Connections

Chapter 4: Programming

This chapter contains two sections that describe the program commands for the analog and digital LDT. Preceding these sections is a description of the types of devices used to program the LDT. For a brief description of all the commands, see Appendix B: Command Summary.

Programming is the method in which a user sends an instruction to the Linear Displacement Transducer (LDT). This is done by the user entering a command letter and/or number(s) through some type of interface or programming device, and then selecting enter in order to send the command to the LDT's Central Processing Unit (CPU). If no errors occur, the LDT will implement the command. Commands are usually represented as a single number or character, but can be accompanied with additional numbers. For example, if you wanted to set a digital LDT to a particular fault output time, you would select the letter "T" on a keyboard, followed by a four-digit number. The number chosen will be the fault output time in microseconds with a decimal carried over two places. (For more information on the method in which a user sends an instruction to the LDT, see either Programming through a PC or Dumb Terminal, or Programming through the Hand-held Programmer following this introduction.)

The following are some examples of how the LDT can be programmed:

- Analog LDTs that have a voltage or current output can have calibration settings or output scaling easily changed.
- Digital LDTs can be put into any mode of operation and have recirculations, wire speed, and offset easily set.
- The functionality during a fault condition can be controlled on all models.
- The model number, serial number, and software revision number can be easily attained on all models.

NOTE: Commands requiring additional numbers or letters can only be programmed through a dumb terminal or personal computer (PC); they cannot be programmed through the hand-held programmer.

4.1: Devices Used to Program the LDT

All Series 951 linear displacement transducers can be programmed through a dumb terminal, PC or factory's hand-held programmer. If you use a PC to program the LDT, you will need a terminal emulation software package. There are many types of terminal emulation software packages on the market, such as PROCOMM PLUS[®], Terminal for Windows[™], or Hyper Terminal[™].

4.2: Programming through a PC or Dumb Terminal

All LDTs can be programmed through a serial communications port using the following parameters: 9600 baud, no parity, 8 data bits, and 1 stop bit. Before you begin to program the LDT through a dumb terminal or PC, you will need to make these settings.

To program the LDT through a dumb terminal or PC, you simply select a command letter and/or number(s) on the keyboard, and then select the keyboard's enter key. The dumb terminal or PC then sends the command to the LDT and waits for a pass or fail response. If the monitor displays the word "PASS", the LDT has accepted the command. But if the monitor displays the word "FAIL", the user will know the LDT has not accepted the command.

4.3: Programming through the Hand-held Programmer

The hand-held programmer is a convenient, pocket-sized device that can interface with the LDT. This eliminates the need for a computer or dumb terminal. This device is battery operated which makes it portable. To operate it, the user simply selects a command letter or number using a switch on the programmer, and then selects the programmer's enter button. A microcomputer inside the programmer then sends the command to the LDT and waits for a pass or fail response. If the programmer's LED illuminates a green light, the user will know the LDT has accepted the command. But if the LED illuminates red, the user will know the LDT has not accepted the command. To purchase the hand-held programmer (part number 951-1405), contact the factory.

NOTE: The hand-held programmer implements command numbers 0 through 9 and command letters A through F. Command letters beyond F can only be accessed through a dumb terminal or PC having a terminal emulation software package.

4.4: Analog Program Commands Defined

This section contains definitions for all the commands that can be sent to an analog LDT. Each command number or letter implements a unique instruction. To implement an instruction, the user simply enters one of the defined command numbers or letters on a keyboard or on the hand-held programmer, and then selects the enter key. (Some command letters require two or more numbers entered after entering the command letter.) If no error occurs, the LDT will implement the command. Before operating your analog LDT, read each of the commands defined in this section. This will help you to become familiar with the instructions you can send. Once you become familiar with each command, you can refer to Appendix B: Command Summary. This chart contains a summary of all the commands described in this chapter and can be used as a quick reference.

NOTE: The hand-held programmer implements command numbers 0 through 9 and command letters A through F. Command letters beyond F can only be programmed through a dumb terminal or a PC having a terminal emulation software package.

1

Enter

Set User Low Point for Active Stroke Area

Command 1 sets the magnet's current position as the lowest value in the active stroke area. For example, factory calibration sets the lowest value for the active stroke are 1.5" from the base of the LDT's hex head. If command 1 were implemented while the magnet was currently positioned 3" from the hex head, the point in the active stroke area that would generate the lowest value then would be 3" from the hex head-no longer 1.5". This command can also be used to reverse the active stroke's output. This would cause a greater output to occur when the magnet is near the LDT's head and

a lesser output to occur when it is near the tip of the guide rail. This is accomplished by using both command 1 and command 2 while properly positioning the magnet before executing each command. It is important to note that setting a new low point through command 1 will shorten or lengthen the current active stroke area. Factory calibration can be restored by executing command 5 or command 6.

2**Enter**

Set User High Point for Active Stroke Area

Command 2 sets the magnet's current position as the highest value in the active stroke area. For example, factory calibration sets the highest value for the active stroke area 2.25" from the tip of the guide rail. If command 2 were implemented while the magnet was currently positioned 4.5" from the tip of the guide rail, the point in the active stroke area that would generate the highest value then would be 4.5" from the tip of the guide rail. This command can also be used to reverse the active stroke's output. This would cause a greater output to occur when the magnet is near the LDT's head and a lesser output to occur when it is near the tip of the guide rail. This is accomplished by using both command 1 and command 2 while properly positioning the magnet before executing each command. It is important to note that setting a high point through command 2 will shorten or lengthen the active stroke area. Factory calibration can be restored by executing command 5 or command 6.

3**Enter**

Set Zero for Active Stroke Area

Command 3 sets the magnet's current position to zero for the active stroke area. Whether or not the LDT is set in a unipolar or bipolar mode, the point in the active stroke area that is set to zero will have a zero volt. Unlike command 1 and 2, this command shifts the active stroke area to agree with the point on the guide rail set to zero.

Not that performing this command may cause the loss or part of all of the LDT's output range. For example, let's consider that your LDT is set in a bipolar mode and generates

0 to +10 volts toward the dead band, and 0 to -10 volts toward the standard null. The LDT has a 12" stroke area, 1.5" null, and a 2.25" dead band. If command 3 were implemented while the magnet was currently positioned at the beginning of the null, the output range 0 to -10 would be lost. This would also produce a larger dead band considering the output range 0 to +10 would be shifted toward the LDT's head. For further explanation, see Figure 4-1. Factory calibration can be re-stored by executing command 5 or command 6.

NOTE: Command 3 was primarily included for voltage models, but on a 4 to 20 mA current model, it sets the 8 mA point to be equal to the present magnet position.

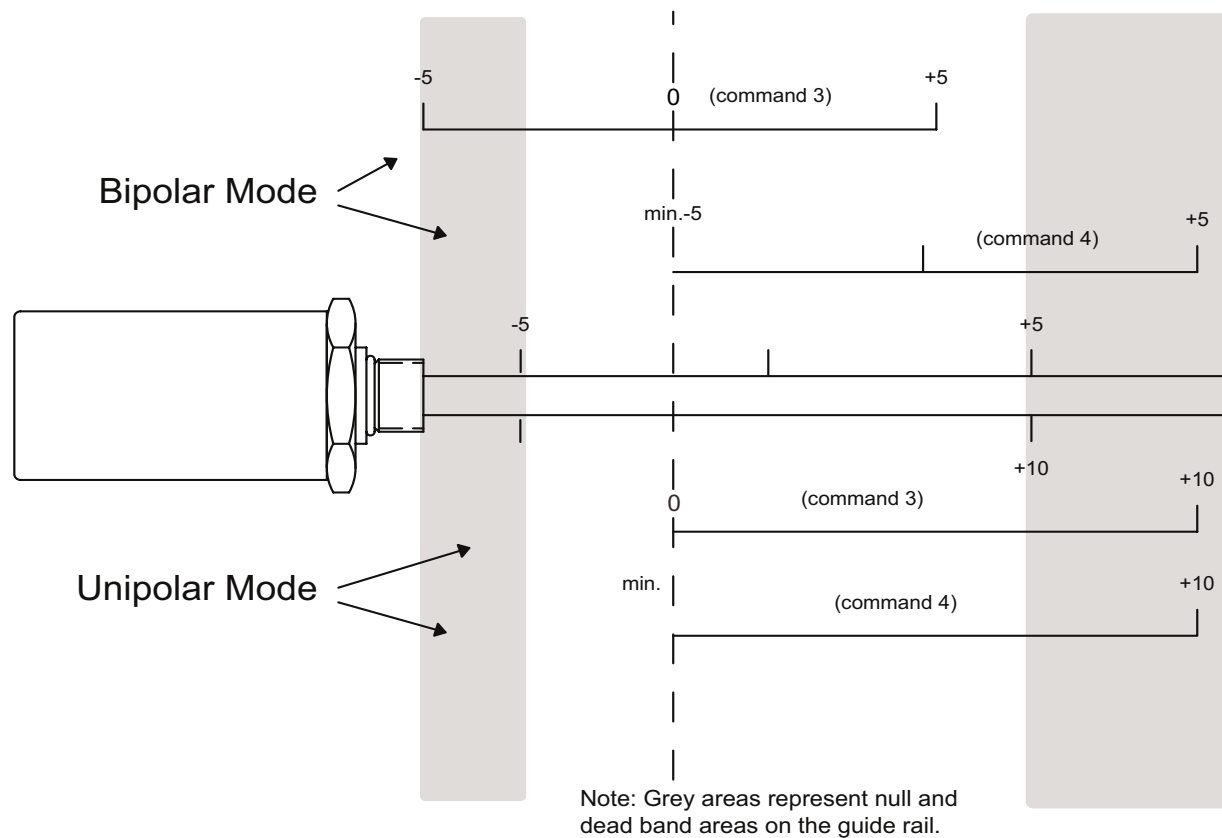

Figure 4-1 Results of Command 3 and Command 4

4**Enter**

Set Minimum for the Active Stroke Area

Command 4 sets the magnet's current position to the minimum voltage for the active stroke area. This is similar to command 1. However, unlike command 1 which can either shorten or lengthen the active stroke area, command 4 will shift the entire active stroke area to agree with the new point of minimum voltage. If the LDT is in unipolar mode, this command will have the same effect as command 3. But if the LDT is in bipolar mode, the new minimum voltage point will be either -5 or -10, depending on what volt range the LDT is using. For further explanation, see Figure 4-1. Factory calibration can be restored by executing command 5 or command 6.

NOTE: Command 4 was primarily included for voltage models, but on a 4 to 20 mA current model, it sets the 4 mA point to be equal to the present magnet position.

5**Enter**

Normal Factory Reset

Command 5 changes the current calibration back to factory calibration. The laser-measured stroke (zero offset, null, active stroke area, and dead band) is reinstalled. *However, unipolar and bipolar, and 5V and 10V modes are not restored to original factory settings by this command.*

6**Enter**

Reversed Factory Reset

Command 6 changes the current calibration to factory calibration in reverse. The laser-measured stroke (zero offset, standard null, active stroke area, and dead band) is reinstalled, but the greater output is near the LDT's head and the lesser output is near the tip of the guide rail. *However, the unipolar and bipolar, and 5V and 10V modes are not restored to original factory settings in reverse by this command.*

7

Enter

Set Bipolar Mode

Command 7 maps the area of active stroke into a bipolar range of voltage from either -5V to +5V, or from -10V to +10V. This command is not available when a custom factory calibration is used.

8

Enter

Set Unipolar Mode

Command 8 maps the area of active stroke into a unipolar range of voltage from 0V to +5V, or from 0V to +10V. This command is not available when a custom factory calibration is used.

9

Enter

Set 5 Volt Mode

Command 9 maps the area of active stroke into either a 0V to +5V range, or a -5V to +5V range. The type of range will depend on whether the LDT is programmed in bipolar mode or unipolar mode. This command is not available when a custom factory calibration is used.

A

Enter

Set 10 Volt Mode

Command A maps the area of active stroke into either a 0V to +10V range, or a -10V to +10V range. This type of range will depend on whether the LDT is programmed in bipolar mode or unipolar mode. This command is not available when a custom factory calibration is used.

NOTE: Commands 7, 8, 9, and A are not available on LDTs which provide a current output.

D

Enter

Disable Position Fault Output Mode

Command D disables the position fault output mode. For more information, see Enable Position Fault Mode.

E**Enter**

Enable Position Fault Output Mode

Command E enables the position fault output mode. In the case of an error occurring during machine operation, this mode allows the LDT to produce a pre-programmed position output voltage that will inform the user that an error occurred.

For example, the magnet assembly generates a voltage as it moves along the active stroke area. However, during normal operation, once the magnet assembly moves outside the active stroke area, the last voltage generated will continue to be generated. As a result, the magnet assembly could continue to move in the wrong direction. To prevent this from happening, you can enable the error condition “Loss of Magnet” in command W. Through command V, you can then program a position fault output voltage. With the position fault output mode enabled during machine operation, the LDT would generate the output programmed in command V if the magnet assembly were to move outside the active stroke area. Note that this example is only one of many ways in which you can use command W and V. For more information, see Set Position Fault Output Voltage (command V) and Set Position Fault Mode (command W).

The position fault output mode can be disabled by implementing command D or by setting the fault output voltage (command W) to zero. It is recommended, however, that command D be used in this case. This is because the LDT does not forget a previously programmed fault output voltage and will reinstate this output if command E is implemented.

Note that error conditions may also be transmitted through the serial port when the diagnostic mode is enabled (command Z).

F**Enter**

Enable Velocity Fault Output Mode

Command F enables the velocity fault output mode. In the case of an error occurring during machine operation, this mode allows the LDT to produce a pre-programmed velocity output voltage that will inform the user that an error occurred.

For example, the magnet assembly generates a certain voltage as it moves along the active stroke area. In normal operations, however, once the magnet assembly moves outside the active stroke area, the last voltage generated will continue to be generated. As a result, the magnet assembly could continue to move in the wrong direction. To prevent this from happening, you can enable the error condition “loss of magnet” in command U. Through command T, you can then program a velocity fault output voltage. With the velocity fault output mode enabled during machine operation, the LDT would generate the output programmed in command T if the magnet assembly were to move outside the stroke area. Note that this example is only one of many ways in which you can use command T and command U. (For more information, see Set Velocity Fault Output Voltage (command T) and Set Velocity Fault Mode (command U).

The velocity fault output mode can be disabled by implementing command D or by setting the velocity fault output voltage (command T) to zero. It is recommended, however, that command D be used in this case. This is because the LDT does not forget a previously programmed velocity fault output voltage and will reinstate this output if command F is implemented.

Note that error conditions may also be transmitted through the serial port when the diagnostic mode is enabled (command Z).

NOTE: Commands that can be programmed by the hand-held programmer end here. The following commands can only be programmed through a dumb terminal or PC having a terminal emulation software package.

M

Enter

Display Model, Serial, and Software Revision Numbers

Command M displays the LDT’s model, serial, and software revision numbers.

Q**Enter**

Disable Diagnostic Mode

Command Q disables the diagnostic mode. The diagnostic mode is enabled through command Z. For more information, see Enable Diagnostic Mode (command Z).

T

Enter fault
output voltage

Set Velocity Fault Output Voltage

Command T sets the velocity fault output voltage. The LDT will generate this output whenever any enabled error condition(s) programmed in command U occurs. Both command U and T work in conjunction to inform the user when an error occurs. To implement command T, enter the command letter followed by a + or - and a four-digit number. This number will have a decimal carried over two places. For example, if you want the LDT to generate a fault output voltage of 3V whenever an enabled error condition(s) occurs, enter command T followed by +0300. For more information, see Set Velocity Fault Mode (command U).

Enter**U**

Enter error
condition value

Set Velocity Fault Mode

Command U enables any or all supported error conditions displayed in Chart 4-1. The LDT will generate the output voltage programmed in command T whenever an enabled error condition(s) programmed in command U occurs. Both command U and T work in conjunction to inform the user when an error occurs. To enable an error condition, select command U followed by one of the two-digit error condition values displayed in Chart 4-1. Note that some of these values enable more than one error condition. An “X” states which error conditions each value enables. Note also that you can select all error conditions at once by selecting the error condition value 15. For more information on programming an output voltage, see Set Velocity Fault Output Voltage (command T).

Enter

Error Condition Values	Magnet Out of Range (bit 3)	Loss of Magnet (bit 2)	Excessive Noise (bit 1)	Mild Noise (bit 0)
00				
01				X
02			X	
03			X	X
04		X		
05		X		X
06		X	X	
07		X	X	X
08	X			
09	X			X
10	X		X	
11	X		X	X
12	X	X		
13	X	X		X
14	X	X	X	
15	X	X	X	X

Chart 4-1 Error Condition Values for Velocity Fault Mode

NOTE: The error condition “Magnet Out of Range” is not guaranteed to be sensed. If the magnet assembly moves beyond the active stroke area fast enough, the error condition “Loss of Magnet” may be the only error to be sensed.

V

Enter fault output voltage

Enter

Set Position Fault Output Voltage

Command V sets the position fault output voltage. The LDT will generate this output whenever any enabled error condition(s) programmed in command W occurs. Both command W and V work in conjunction to inform the user when an error occurs. To implement command V, enter the command letter followed by a + or - and a four-digit number. This number will have a decimal carried over two places. For example, if you want the LDT to generate a fault output voltage of 1.25V whenever an error condition(s) occurs, enter command V followed by +0125. For more information, see Set Position Fault Mode (command W).

WEnter error
condition value**Enter****Set Position Fault Mode**

Command W enables any or all supported error conditions displayed in Chart 4-2. The LDT will generate the output voltage programmed in command V whenever an enabled error condition(s) programmed in command W occurs. Both command V and W work in conjunction to inform the user when an error occurs. To enable an error condition, select command W followed by one of the two-digit error condition values displayed in Chart 4-2. Note that some of these values enable more than one error condition. An “X” states which error conditions each value enables. Note also that you can select all error conditions at once by selecting the error condition value 15. For more information on programming an output voltage, see Set Position Fault Output Voltage (command V).

Error Condition Values	Magnet Out of Range (bit 3)	Loss of Magnet (bit 2)	Excessive Noise (bit 1)	Mild Noise (bit 0)
00				
01				X
02			X	
03			X	X
04		X		
05		X		X
06		X	X	
07		X	X	X
08	X			
09	X			X
10	X		X	
11	X		X	X
12	X	X		
13	X	X		X
14	X	X	X	
15	X	X	X	X

Chart 4-2 Error Condition Values for Position Fault Mode

NOTE: The error condition “Magnet Out of Range” is not guaranteed to be sensed. If the magnet assembly moves beyond the active stroke area fast enough, the error condition “Loss of Magnet” may be the only error to be sensed.

Z**Enter**

Enable Diagnostic Mode

Command Z enables the diagnostic mode. When an error condition occurs, this mode will allow the LDT to display a single ASCII character on the screen. A displayed character corresponds to a particular error condition. Possible characters that can be displayed can be found in Chart 4-3. Shaded areas in Chart 4-3 are not valid error conditions and are included only to illustrate the continuity in the numbers used. To disable the diagnostic mode, implement command Q.

The following are descriptions of the possible characters that can be displayed when the diagnostic mode is enabled:

- a** This letter indicates the LDT is experiencing mild noise.
- b** This letter indicates the LDT is experiencing excessive noise. Mild and excessive noise are both the same from the user's point of view. They both mean that the patented signal validation system has invalidated the last input data. (Internal LDT operations make use of some data if the noise is only mild).

NOTE: It is common for the LDT to experience vibration or electrical noise. All magnetostrictive transducers of this type are subject to disturbances without this noise affecting the operation of the LDT.

- d** This letter indicates the LDT has lost its magnet. If the magnet were lost while excessive noise was occurring, the letter "c" would only be displayed on the screen.
- h** This letter indicates that an interruption in the power supply had occurred and that the LDT's microprocessor has reset itself. This is generally not seen unless power is removed and reapplied to the LDT.

Character	Hex Value	ASCII Decimal Value	Power Supply Interruption (bit 3)	Loss of Magnet (bit 2)	Excessive Noise (bit 1)	Mild Noise (bit 0)
	60	96				
a	61	97				X
b	62	98			X	
	63	99			X	X
d	64	100		X		
	65	101		X		X
	66	102		X	X	
	67	103		X	X	X
h	68	104	X			
	69	105	X			X
	6A	106	X		X	
	6B	107	X		X	X
	6C	108	X	X		
	6D	109	X	X		X
	6E	110	X	X	X	
	6F	111	X	X	X	X

Chart 4-3 Diagnostic Mode Message Interpretation

4.5: Digital Program Commands Defined

This section contains definitions for all the commands that can be sent to a digital LDT. Each command number or letter implements a unique instruction. To implement an instruction, the user simply enters one of the defined command numbers or letters on a keyboard or on the hand-held programmer, and then selects the enter key. (Some command letters require two or more numbers entered after entering the command letter.) If no error occurs, the LDT will implement the command. Before operating your digital LDT, read each of the commands defined in this section. This will help you become familiar with the instructions you can send. Once you become familiar with each command, you can refer to Appendix B: Command Summary. This appendix contains a summary of all the commands described in this chapter and can be used as a quick reference.

NOTE: The hand-held programmer can program command numbers 0 through 9 and command letters A through F. Command letters beyond F can only be programmed through a dumb terminal or PC having a terminal emulation software package.

Set Recirculations

Enter one of the command numbers from 0-7

Enter

Each command number from 0-7 increases the current measurement resolution by multiplying the current wire speed by a set factor. Factors of each command are displayed in Chart 4-4.

Command	Factor
0	x1
1	x2
2	x4
3	x8
4	x16
5	x32
6	x64
7	x128

Chart 4-4 Recirculation Commands Defined

8

Enter

Set Normal Mode

Command 8 configures the LDT to operate in normal mode. In this mode, the pulse's time increases as the magnet assembly moves toward the tip of the guide rail. The LDT is defaulted to this mode, therefore, this command has no effect if the LDT has not been set in reversed mode through the use of command 9.

9

Enter

Set Reversed Mode

Command 9 configures the LDT to operate in reversed mode. In this mode, the pulse's time increases when the magnet assembly moves toward the LDT's head assembly. Normal operation can be resumed when command 8 is implemented.

A **Enter**

Set Controlled Pulse Mode

Command A configures the LDT to operate as a 951CP (Controlled Pulse). In this mode, an external device is required to generate a start pulse. The LDT will then generate a stop pulse of 1.0 microsecond in width. The time between the leading edge of the start pulse to the leading edge of the stop pulse is the proportional distance between the magnet to the hex head. The order of these two pulses is illustrated in Figure 3-5.

B **Enter**

Set Variable Pulse with Internal Interrogation Mode

Command B configures the LDT to operate as a 951VP (Variable Pulse) that uses an internal interrogation. In this mode, the LDT will continually send stop pulses. The width of these stop pulses are proportional to the distance from the magnet to the hex head. These stop pulses are illustrated in Figure 3-8.

C **Enter**

Set Variable Pulse with External Interrogation Mode

Command C configures the LDT to operate as a 951 VP (Variable Pulse) that uses an external interrogation. In this mode, an external device is required to generate a start pulse. This start pulse must be a minimum of 0.2 microseconds in width. Within 2.0 microseconds after the start pulse has been generated, the LDT will generate a stop pulse. The width of the stop pulse is proportional to the distance from the magnet to the hex head. The order of these two pulses is illustrated in Figure 3-7.

D **Enter**

Set Start/Stop Mode

Command D configures the LDT to operate as a 951RS/TP (Start/Stop). In this mode, an external device is required to generate a start pulse. This start pulse must be a minimum of 0.2 microseconds in width. Within 2.0 microseconds after the start pulse begins, the LDT will generate a start pulse of 1.0 microsecond in width. A stop pulse of 1.0 microsecond in width will follow. The time it takes from the leading edge of the start pulse to the leading edge of the stop pulse is the proportional distance between the magnet to the hex head. The order of these two pulses is illustrated in Figure 3-10.

E **Enter**

Enable Fault Output Mode

Command E enables the fault output mode. In the case of an error occurring during machine operation, this mode allows the LDT to produce a pre-programmed output pulse that will inform the user that an error occurred.

For example, the magnet assembly generates certain pulses as it moves along the active stroke area. However, during normal operation, once the magnet assembly moves outside the active stroke area, no pulse will be generated. As a result, the magnet assembly could continue to move in the wrong direction. To prevent this from happening, you can enable the error condition “Loss of Magnet” in command W. Through command T, you can then program a fault output time. (See commands W and T for more information.) With the fault output mode enabled during machine operation, the LDT would generate the output programmed in command T if the magnet assembly were to move outside the active stroke area. Note that this example is only one of many ways in which you can use command W and T. For more information, see Set Fault Output Time (command T) and Set Fault Output Mode (command W).

Note that error conditions may also be transmitted through the serial port when the diagnostic mode is enabled (command Z).

F **Enter**

Disable Fault Output Mode

Command F disables the fault output mode. For more information, see Enable Fault Output Mode.

NOTE: Commands that can be programmed by the hand-held programmer end here. The following commands can only be programmed through a dumb terminal or PC containing a terminal emulation software package.

G **Enter**

5 Volt Mode Enable

Command G enables an internal circuit to bias the minus RS-422 input at 2.5 volts. The positive RS-422 input then can be used as a single 0 to 5 volt input with a switching threshold of 2.5 volts.

WARNING: Do not have any wires connected to the minus RS-422 input when using command G.

H **Enter**

5 Volt Mode Disable

Command H restores the LDT to a true RS-422 operation. For more information, see 5 Volt Mode Enable.

L **Enter**

Set Low Time for Variable Pulse Using Internal Interrogation

Command L sets the low time or period between the output pulses generated by a 951VP (Variable Pulse) using internal interrogation, or an LDT simulation a 951VP using internal interrogation. To implement command L, enter the command letter followed by a four-digit number. This number will have

a decimal carried over two places. For example, if you want the LDT to generate a low time of 1.00 microsecond, enter command L followed by 0100. Once this is entered, the LDT automatically computes the longest possible output pulse width.

For example, with the low time set at 1.00 microsecond, and the wire speed set at 9.0 microseconds with an offset of 2.84 inches at the threads, a 12" probe would have the following period for the longest possible output pulse:

{[NULL: 1.1"] + STROKE + 0.25" + OFFSET] x a wire speed of 9.00 microseconds x recirculation} + low time = longest possible output pulse.

{[(1.5 - 1.1") + 12" + 0.25" + 2.84"] x (9.00 micro sec.x1)} + 100 micro sec. = 0.239 micro sec.

NOTE: The longest possible output pulse will be recalculated whenever the wire speed, offset, or recirculation is changed.

M **Enter**

Display Model, Serial, and Software Revision Numbers

Command M displays the LDT's model, serial, and software revision numbers on the screen.

O

Enter wire
offset value

Enter

Set Wire Offset

Command O sets the offset for the output pulse. This offset is the value that is output when the magnet is 1.1 inches from the mounting hex base (see glossary) which is 0.1 inches from the threads. The time of the output pulse with the magnet at 0.1 inches from the threads is equal to this offset times (x) the wire speed times (x) the recirculation.

The default offset is 2.84 inches which results in a pulse time of 25.6 microseconds at the point 1.1 inches from the mounting hex base.

Q **Enter**

Disable Diagnostic Mode

Command Q disables the diagnostic mode. For more information, see Enable Diagnostic Mode (command Z).

SEnter wire
speed value**Enter**

Set Wire Speed

Command S sets the wire speed for the output pulse. The default is 9.000 microseconds per inch. To change this, enter command S followed by a five-digit number. This number will have a decimal carried over three places. For example, if you wanted to change the wire speed to 1.0 microseconds per inch, you would select the command S followed by 01000.

TEnter fault
output time
value**Enter**

Set Fault Output Time

Command T sets the fault output time. The LDT will generate this output whenever any enabled error condition(s) in command W occurs. Both command W and T work in conjunction to inform the user when an error occurs. To implement command T, enter the command letter followed by a four-digit number. This number will have a decimal carried over three places. For example, if you want the LDT to generate a fault output time of 2.4 milliseconds, you would enter command T followed by 2400. For more information, see Set Fault Output Mode (command W).

WEnter error
condition
value**Enter**

Set Fault Output Mode

Command W enables any or all supported error conditions displayed in Chart 4-5. The LDT will generate the output pulse programmed in command T whenever an enabled error condition(s) programmed in command W occurs. Both command W and T work in conjunction to inform the user when an error occurs. To enable an error condition, select command W followed by one of the two-digit error condition values displayed in Chart 4-5. Note that some of these values enable more than one error condition. An “X” states which error conditions each value enables. Note also that you can select

all error conditions at once by selecting the error condition value 15. For more information on programming an output pulse, see Set Fault Output Time (command T).

Error Condition Values	Magnet Out of Range (bit 3)	Loss of Magnet (bit 2)	Excessive Noise (bit 1)	Mild Noise (bit 0)
00				
01				X
02			X	
03			X	X
04		X		
05		X		X
06		X	X	
07		X	X	X
08	X			
09	X			X
10	X		X	
11	X		X	X
12	X	X		
13	X	X		X
14	X	X	X	
15	X	X	X	X

Chart 4-5 Error Condition Values for Fault Output Mode

NOTE: The error condition “Magnet Out of Range” is not guaranteed to be sensed. If the magnet assembly moves beyond the active stroke area fast enough, the error condition “Loss of Magnet” may be the only error to be sensed.



Enable Diagnostic Mode

Command Z enables the diagnostic mode. When an error condition occurs, this mode will allow the LDT to display a single ASCII character on the screen. A displayed character corresponds to a particular error condition. Possible characters that can be displayed can be found in Chart 4-6. Shaded areas in Chart 4-6 are not valid error conditions and

are included only to illustrate the continuity in the numbers used. To disable the diagnostic mode, implement command Q.

The following are descriptions of the possible characters that can be displayed when the diagnostic mode is enabled:

- a** This letter indicates the LDT is experiencing mild noise.
- b** This letter indicates the LDT is experiencing excessive noise. Mild and excessive noise are both the same from the user's point of view. They both mean that the patented signal validation system has invalidated the last input data. (Internal LDT operations make use of some data if the noise is only mild.)

NOTE: It is common for the LDT to experience vibration or electrical noise. All magnetostrictive transducers of this type are subject to disturbances without this noise affecting the operation of the LDT.

- d** This letter indicates the LDT has lost its magnet. If the magnet were lost while excessive noise was occurring, the letter "c" would only be displayed on the screen.
- h** This letter indicates that an interruption in the power supply had occurred and that the LDT's microprocessor has reset itself. This is generally not seen unless power is removed and reapplied to the LDT.

Character	Hex Value	ASCII Decimal Value	Power Supply Interruption (bit 3)	Loss of Magnet (bit 2)	Excessive Noise (bit 1)	Mild Noise (bit 0)
	60	96				
a	61	97				X
b	62	98			X	
	63	99			X	X
d	64	100		X		
	65	101		X		X
	66	102		X	X	
	67	103		X	X	X
h	68	104	X			
	69	105	X			X
	6A	106	X		X	
	6B	107	X		X	X
	6C	108	X	X		
	6D	109	X	X		X
	6E	110	X	X	X	
	6F	111	X	X	X	X

Chart 4-6 Diagnostic Mode Message Interpretation

Appendix A: Troubleshooting

Before beginning this appendix, a diagnostic check should be made. If your LDT is connected to a PC or dumb terminal, you can enable the LDT's diagnostic mode. When an error condition occurs, this mode will allow the LDT to display a single ASCII character on the screen. A displayed character corresponds to a particular error condition. For information on this mode, see Enable Diagnostic Mode on page 38 if you have an analog LDT, or page 47 if you have a digital LDT.

Troubleshooting describes common problems that may occur when installing the LDT and offers solutions to these problems. If, after reading this appendix, you are unable to resolve a problem, contact factory. Troubleshooting is divided into the following two groups:

- General Checks
- Power Supply

General Checks

Make sure that the magnet is located within LDT's active stroke area. Captive magnet assemblies should be positioned so that they can move freely over the entire area of the active stroke without binding or pushing on the guide rail. Non-captive magnet assemblies should be situated so that the magnet is no farther than 0.2" from the guide rail at any point in the magnet assembly's movement.

NOTE: Ferromagnetic material (material readily magnetized) should be located no closer than 0.25" from the magnet or LDT guide rail. This includes mounting brackets, magnet spacers, magnet brackets, and mounting screws. Ferromagnetic material can distort the magnetic flux, causing adverse operation or failure of the LDT.

Check all LDT wires for continuity and/or shorts. It is preferable that the cable between the LDT and the interface device be one continuous run. If you are using a junction box, it is highly recommended that the splice junction box be free of AC and/or DC transient-producing lines. The shield should be carried through the splice and terminated at the interface device end.

Power Supply Checks

This section will help you to determine whether or not a) your power supply provides enough power for the LDT to operate properly; b) the LDT's cable does not have a short; or c) the LDT is inoperative.

In order for the LDT to operate properly, the LDT's external power supply must provide a level between +15 and +26 VDC. A power supply providing power above this specified range may cause damage to the LDT. A power supply providing power below this specified range will not be sufficient to power the LDT. When using more than one LDT for one power supply, each LDT requires a maximum of three watts of power. The amount of current draw will vary based on the input voltage used. To calculate the exact current draw for a particular LDT, divide 3 by the input voltage for the current draw value. For example, 3 watts divided by 24 VDC equals 125 mA.

If your LDT is not operating properly, the LDT's cable may have an open or short, or the power supply is not supplying sufficient power. To verify this, perform the following steps:

1. Turn power supply off.
2. Remove the mating connector from the LDT.
3. Turn power supply on.
4. Using a digital voltmeter, check pins B and C from the mating end of the cable for a level between +15 and +26 VDC.

NOTE: LDT's with potted pigtail assemblies should be checked for proper voltage at the power supply terminals; a potted pigtail cable cannot be removed from the LDT

If reading is between +15 and +26 VDC, turn power supply off and go to step 7. If reading is below +15 VDC, either your power supply is not providing enough power or the LDT's cable has a short. Readings of no voltage or minimal voltage (less than 5 volts) may be due to a short in the cabling. If reading is *not* between +15 and +26 VDC, go to step 5. If reading is above +26 VDC, adjust power supply or replace.

5. Turn power supply off.
6. Ring out the cable between the power supply and the LDT. Check for continuity from one end of the cable to the other, as well as pin-to-pin continuity to verify that no shorts exist between pins.
7. Reconnect the mating connector to the LDT.
8. Turn power supply on.
9. Using a digital voltmeter, check the power supply's + and - terminals for a voltage between +15 and +26 VDC.

Low voltage readings may indicate a power supply with a wattage rating that is too low. (Each LDT requires 3 watts.) If the cabling checks out in step 6 and your voltage is below +15 VDC, contact factory.

Appendix B: Command Summary

This appendix contains two command summary charts for analog and digital LDT commands. Before referring to these charts, it is recommended that you read each command description found in Chapter 4 which relates to your specific LDT. These descriptions are intended to give you a full understanding of how the LDT will respond to each command.

ANALOG COMMAND SUMMARY	
Command	Function of Command
1	Sets the magnet's current position as the lowest value in the active stroke area.
2	Sets the magnet's current position as the highest value in the active stroke area.
3	Sets the magnet's current position to zero for the active stroke area.
4	Sets the magnet's current position to the minimum voltage for the active stroke area.
5	Changes the LDT's current calibration back to factory calibration.
6	Changes the LDT's current calibration to factory calibration in reverse.
7	Maps the area of active stroke into a bipolar range of voltage.
8	Maps the area of active stroke into a unipolar range of voltage.
9	Maps the area of active stroke into either a 0V to +5V range, or a -5V to +5V range.
A	Maps the area of active stroke into either a 0V to +10V range, or a -10V to +10V range.
D	Disables the position fault output mode.
E	Enables the position fault output mode.
F	Enables the velocity fault output mode.
M	Displays the LDT's model, serial, and software revision numbers.
Q	Disables the diagnostic mode.
T	Sets the velocity fault output voltage. The user must enter a + or - and a four-digit number (number is programmed with a decimal carried over two places) following the command letter.
U	Enables any or all supported error conditions. The user must enter the error condition's value after the command letter.
V	Sets the position fault output voltage. The user must enter a + or - and a four-digit number (number has a decimal carried over two places) following the command letter.
W	Enables any or all supported error conditions. The user must enter the error condition's value after the command letter.
Z	Enables the diagnostic mode.

Chart A-1 Analog Command Summary

DIGITAL COMMAND SUMMARY	
Command	Function of Command
0	Multiplies wire speed by 1.
1	Multiplies wire speed by 2.
2	Multiplies wire speed by 4.
3	Multiplies wire speed by 8.
4	Multiplies wire speed by 16.
5	Multiplies wire speed by 32.
6	Multiplies wire speed by 64.
7	Multiplies wire speed by 128.
8	Configures the LDT to operate in normal mode.
9	Configures the LDT to operate in normal mode reversed.
A	Configures the LDT to operate as a 951CP.
B	Configures the LDT to operate as a 951VP using an internal interrogation.
C	Configures the LDT to operate as a 951VP using an external interrogation.
D	Configures the LDT to operate as a 951RS/TP.
E	Enables the fault output mode.
F	Disables the fault output mode.
G	Enables an internal circuit to bias the minus RS-422 input at 2.5 volts.
H	Restores the LDT to a true RS-422 operation.
L	Sets low time between output pulses generated by a 951VP with internal interrogation, or LDT simulating this type of pulse.
M	Displays LDT's model, serial, and software revision number.
O	Sets the offset for the output pulse. The user must enter a five-digit number (number has a decimal carried over three places) following the command letter.
Q	Disables the diagnostic mode.
S	Sets the wire speed for the output pulse. The user must enter a five-digit number (has a decimal carried over three places) following the command letter.
T	Sets the fault output time. User must enter a four-digit number (number has a decimal carried over two places) following the command letter.
W	Enables any or all supported error conditions. The user must enter the error condition's value after the command letter.
Z	Enables the diagnostic mode.

Chart A-2 Digital Command Summary

Appendix C: Specifications

General Specifications

Guide Rail	316 Stainless Steel, 0.405" (10.29 mm) outer diameter.
End Plug	316 Stainless Steel, Brazed End Assembly, 0.405" (10.29 mm) outer diameter.
Mounting Hex	316 Stainless Steel, 1.75" (44.45 mm) across flats.
Mounting Threads	3/4-16 x 1.00" (25.4 mm) with ESNA Jam Nut and O-ring seal.
Head Assembly	Thick Wall Aluminum Cover with Viton O-ring Standard Gasket Seal at the Base and Connector Exit, NEMA 6.
Connector	1/4 turn MS-Style Standard (quick connect/disconnect) Connector. Potted Pigtail Assembly (optional).
Displacement	Up to 25ft. (7.6 m), Standards to 10 ft. (3.05 m).

Electrical Specifications

Input Voltage	+15 VDC to +26 VDC
Current Draw	3 watts maximum (200 mA at 15 VDC); power consumption does not vary with magnet position or type of output being used.
Dead Band	2.25: (57.15 mm)
Standard Null	1.5" (38.1 mm)
Head Enclosure	3" (76.20 mm) high with 1.75" (44.45 mm) diameter; hex and cover are NEMA 6.

Nonlinearity	Less than 0.05% of full stroke with +/- 0.002" (+/- 0.05 mm) maximum +/- 0.002: or .05% of full stroke, whichever is greater.
Hysteresis	.001" (0.025 mm) maximum.
Repeatability	+/-0.001% of full stroke or 0.0004" (0.0102 mm), whichever is greater.
Frequency Response	Stroke Dependent, 1 kHz to 250 Hz is typical for lengths of 12" (304.8 mm) to 120" (3048 mm) respectively.

Temperature Coefficient

LDT: Less than 0.00011 in./Degree F + [3 PPM/Degree F/in. of Full Stroke] (Less than 0.00503 mm/Degree C+ [5.4 PPM/Degree C/mm of Full Stroke]).

Analog Output Type: 10 PPM/Degree F (18 PPM/Degree C)

Operating Temperature

Head (Electronics): -40 to +155° F (-40 to +70° C)

Guide Tube: -40 to +220° F (-40 to +105° C)

Operating Pressure 3000 psi Constant, 8000 psi Peak

Outputs

Analog (position):	-10 to +10 VDC	16 bits (65,535) resolution
	0 to +10 VDC	15 bits (32,768) resolution
	-5 to +5 VDC	15 bits (32,768) resolution
	0 to +5 VDC	14 bits (16,384) resolution
	0 to 20 / 4 to 20 mA	16 bits (65,535) resolution

Analog (velocity):	0 to +/-10 VDC	12 bits (4096) resolution
	0 to +/-5 VDC	11 bits (2048) resolution

Digital: TTL Level Pulse/Pulse, RS-422 Pulse/Pulse, RS-422 Pulse-width Modulated. (BCD, Binary, or Gray Code Outputs available from the Series 2120L1 Module.)

Velocity Output
(Analog Only) 0 to +/-10 VDC or 0 to +/-5 VDC. Positive voltage traveling away from the head assembly; negative voltage traveling toward the head assembly.

Additional Analog Specifications

Minimum Load Resistance 2K ohm minimum load for voltage output

Output Current Guaranteed 6 mA minimum for voltage units

Maximum Load Resistance Max. load (ohms) = (input voltage -2) / .02

Velocity Output 0 to +/-10 VDC for voltage output
4 to 20 mA for current output LDTs

Analog Ripple <1 mV maximum (position output)
<5 mV maximum (velocity output)

Update Time 2 ms (stroke lengths to 100") 2-4 ms (stroke lengths over 100")

Temperature

Storage: -40 to +180° F (-40 to +82° C)
Operating: -40 to +155° F (-40 to +68° C)
Coefficient: 10 PPM/° F (18 PPM/° C)

Glossary

Active Stroke Area	The area designated by the operator on the guide rail on which the magnet assembly moves.
Bipolar	An active stroke area having a bipolar range from either -5V to +5V, or from -10V to +10V.
Command	A letter and/or number(s) that, when implemented, sends an instruction to the LDT's CPU through an interface device.
Connect/Disconnect Connector	A connector which can be quickly connected or disconnected from the LDT's terminals by turning the connector 1/4 of a turn and then pulling.
Dead Band	An area usually 2.25" on the guide rail which begins at the tip of the guide rail; the area which follows going toward the head assembly is the active stroke area.
End Plug	A stainless steel plug factory brazed at the tip of the guide rail.
External Device	A device wired to the LDT which generates external interrogations.
External Interrogations	Pulses sent by an external device to the LDT, usually to initiate a pulse sequence.
Fault Mode	When enabled, this mode allows a digital or analog LDT to generate a programmed fault output time or voltage when an error condition occurs. Referred more specifically as Position Fault Mode for the analog LDT, and Fault Output Mode for the digital LDT.
Fault Output Time	A time programmed in command T so that during a fault condition, the digital LDT will generate this fault output time.
Fault Output Voltage	A voltage programmed in command V so that during a fault condition, the analog LDT will generate this fault output voltage.
Guide Rail	A stainless steel tube on which the magnet assembly travels.
Hand-held Programmer	A pocket-sized device that can interface with the LDT. It can implement command numbers 0 through 9 and command letters A through F. To implement commands beyond this point, a dumb terminal or PC using a terminal emulation software package must be used.

Head Assembly	An enclosure used to house the LDT's electrical components.
Hysteresis	The dependence of the state of a system on its previous history, generally in the form of a lagging of a physical effect behind its cause.
Interface Device	A device which is used to send commands to the LDT and can receive messages from the LDT. Examples of an interface device include a dumb terminal or PC using a terminal emulation software package, and the factory's hand-held programmer.
Internal Interrogation	Pulses generated by the LDT usually to initiate a pulse sequence.
Jam Nut	A nut which screws onto threads protruding from the hex mounting base. This nut is used to secure on half of the LDT.
LDT	Linear Displacement Transducer
Low Pulse	The duration between two output pulses generated by a 951VP using internal interrogation. This pulse is also referred to as a low output.
Magnet Assembly	A non-magnetic ring that moves across the LDT's guide rail.
Magnetic Spacer	A 0.25" thick, non-magnetic part which separates the magnet assembly from the head of a hydraulic cylinder's piston rod. This is to ensure the magnet assembly is no closer than 0.25" from the magnetic material of the piston rod.
Mounting Hex	A ferromagnetic hex found at the front of the LDT's head assembly where the guide rail protrudes out. This hex can be used when tightening the LDT into a bracket.
Mounting Hex Base	A ferromagnetic base of the mounting hex. This point is where the mounting hex threads begin to protrude from the mounting base.
Potted-Pigtail Assembly	A cable that is permanently installed at the factory to the LDT.
Recirculations	The method used to improve the resolution of a system using one of the digital LDTs. The "on" time of a pulse width output is multiplied by a specific factor (binary increment from 1-128). This multiplication provides more counting time for the counter in the customer's electronics, thus improving the resolution. The only disadvantage to higher recirculation numbers is the time needed to process the signals.

Return (Stop) Pulse	A pulse returned to the LDT's coil to determine the location of the magnet assembly on the guide rail.
R11 Modular Jack	The recommended way to connect the LDT's communications wires to the interface device.
Null	An area usually covering 1.5" on the guide rail beginning at the threads protruding from the hex mounting base; the area on the guide rail which follows the standard null going toward the tip of the guide rail is the active stroke area.
Start Pulse	A pulse generated by either an external device or the LDT to start a pulse sequence.
Stop Pulse	A pulse returned to the LDT's coil which indicates the location of the magnet assembly on the guide rail by the width of the pulse.
Unipolar	An active stroke area having a unipolar range between either 0V to +5V or from 0V to +10V.
Wire Offset	The distance between the coil inside the LDT's head assembly and 0.1 inches from the end of the threads protruding from the mounting hex. The LDT is defaulted to have a wire offset of 2.84 inches.
Wire Speed	The time it takes a pulse to travel the guide rail in inches. For example, an LDT set to a wire speed of 9.0 microseconds will cause pulses to travel its guide rail at a speed of 9.0 microseconds per inch.



AMETEK Automation & Process Technologies • 1080 N. Crooks Road • Clawson, MI 48017
800-635-0289 • 248-435-0700 • Fax 248-435-8120
www.ametek.com • www.ametekapt.com

905 951.M1R 10/01.Z120 1M
