

955 Series



INSTALLATION MANUAL

LINEAR DISPLACEMENT TRANSDUCERS

955D BRIK

GEN III WITH DIGITAL OUTPUT



**Includes 955D
Programming & Maintenance
Instructions Plus Accessory Guide**

**ABSOLUTE PROCESS CONTROL
KNOW WHERE YOU ARE... REGARDLESS**



Preface

This manual is divided into three chapters. Chapter 1 provides the hardware overview for the 955D Linear Displacement Transducers (LDT). Chapter 2 provides instructions for installing the LDT to a mounting bracket. Chapter 3 provides an overview and wiring instructions. To further assist you, a glossary is provided at the back of the manual.



Disconnect Power Before Servicing. The Gemco 955D LDT Contains No Serviceable Components. Consult Factory for Repair or Replacement.

AMETEK Automation & Process Technologies has checked the accuracy of this manual at the time it was approved for printing. However, this manual may not provide all possible ways of installing and maintaining the LDT. Any errors found in this manual or additional possibilities to the installation and maintenance of the LDT will be added in subsequent editions. Any comments you may have for the improvement of this manual are welcomed.

AMETEK reserves the right to revise and redistribute the entire contents or selected pages of this manual. All rights to the contents of this manual are reserved by AMETEK. The BRIK is a registered trademark of AMETEK.

Table of Contents

- Chapter 1 Hardware Overview..... 3**
- Chapter 2 Installing the LDT 3**
 - 2.1 Mounting Instructions 3
 - 2.2 Mounting the Magnet Assembly 3
- Chapter 3 955D Outputs 5**
 - 3.1 CP (Control Pulse) 5
 - 3.2 VP (Variable Pulse) 5
 - 3.3 RS (Start/Stop)..... 6
 - 3.4 955D Wiring Connections 6
 - 3.5 Features 7
 - 3.6 Troubleshooting for 955D 8
 - 3.7 Catalog Numbering System 9
 - 3.8 Specifications for 955D 10
 - 3.9 Accessories 10
- 955D Glossary 11**



Chapter 1 Hardware Overview

Overview

The Series 955D BRIK with Digital Output is an accurate, auto-tuning, non-contact, Linear Displacement Transducer in an economical, low profile package. The transducer utilizes our field proven magnetostrictive technology to give absolute position, repeatable to .006% of the sensing distance. The streamlined anodized aluminum extrusion houses the sensing element and electronics. The magnet moves over the sensing element that determines the position and converts it to a digital output.

Features

The 955D has a truly unique feature. This LDT has auto-tuning capability, the ability to sense a magnet other than the standard slide magnet and adjust its signal strength accordingly.

There is an indicator LED that is located at the connector end of the probe and provides visual status information regarding the operation of the probe. Green indicates proper or normal operation. Red indicates the loss of the magnetic signal or a probe failure. The LED turns Yellow if no interrogation signal detected. When the probe is in the normal mode of operation, the LED will remain illuminated continuously.

LED Colors	
Green	Magnet is present and within the active range.
Red	Fault, the LDT has lost its signal from the magnet or the magnet has moved into the Null Zone or Dead Band.
Yellow	No external interrogation pulse detected.

Note: The series number on your LDT is a record of all the specific characteristics that make up your unit. This includes what interface type it is, its output signal and range, the type of connector the unit uses, and stroke length. For a translation of the model number, see Section 3.7 Catalog Numbering System.

The 955D BRIK with Digital Output is a Linear Displacement Transducer. It provides a Control Pulse, Start/Stop or Variable Pulse output signal that is proportional to the position of the slide magnet assembly along the length of the probe.

Chapter 2 Installing the LDT

2.1 Mounting Instructions

The Series 955D can be mounted vertically or horizontally using SD0522000 mounting brackets. The mounting brackets slide in the grooves on the lower part of the extrusion and clamp down when tightened. It is recommended to use one mounting bracket on each end and every three feet in between.

Ferro-magnetic material, (material readily magnetized) should be placed no closer than .25" from the sensing surface of the LDT.

2.2 Mounting the Magnet Assembly

Before mounting the magnet assembly, you should consider the following

- Ferromagnetic material should not be placed closer than 0.25" from the LDT's sensing surface. Failure to do so could cause erratic operation. Non-ferrous materials, such as brass, copper, aluminum, nonmagnetic stainless steel or plastics, can be in direct contact with the magnet assembly and sensing surface without producing any adverse results.
- Make sure that the magnet is located within the LDT's active stroke area. Captive magnet assemblies should be positioned so that they can move freely over the entire area of the active stroke without binding or pushing on the extrusion. Non-captive magnet assemblies should be situated so that the magnet is no further than 3/8" from the sensing surface at any point in the floating magnet assembly's movement.
- When using the Floating Magnet assembly (SD0522100), the magnet should be installed within 3/8" of the sensing surface. The magnet assembly should also be installed in such a manner that it remains an even distance from the aluminum extrusion throughout the entire stroke. Improperly installed magnets can result in output signal non-linearity.

Dimension Drawing

Item	Part Number
Slide Magnet	SD0521800
Float Magnet	SD0522100
Mounting Foot	SD0522000
6 Ft. Cable (6 Pin, Straight Micro Connector, Option E)	949021L6
12 Ft. Cable (6 Pin, Straight Micro Connector, Option E)	949021L12
6 Ft. Cable (6 Pin, Right Angle Micro Connector, Option E)	949022L6
12 Ft. Cable (6 Pin, Right Angle Straight Micro Connector, Option E)	949022L12

A standard female swivel mounting arm is provided with the slide magnet assembly. For extensions and other options contact AMETEK at 800-635-0289.

Mounting Brackets (SD0522000) slide in the grooves on the side of the extruded housing. When tightened down with fastening hardware the mounting bracket clamps the unit into place. It is recommended to use one mounting bracket on each end and every three feet between.

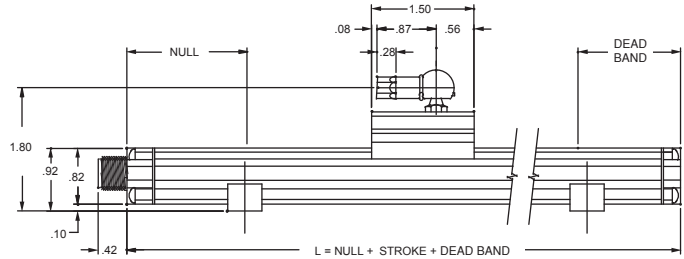
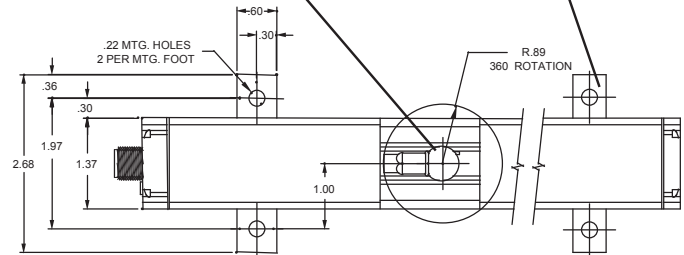
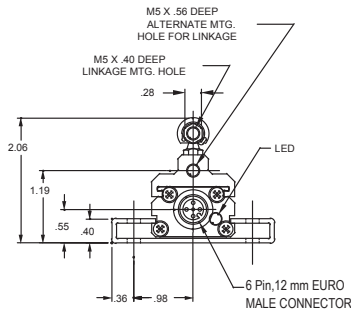

FLOATING MAGNET ASSEMBLY P/N SD0522100

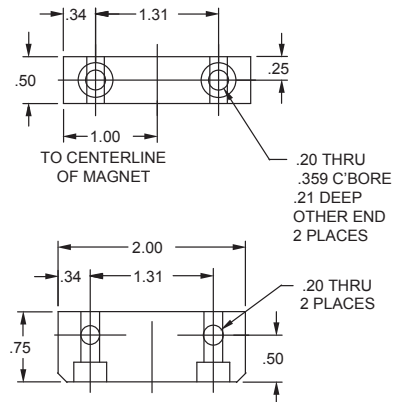

SLIDE MAGNET ASSEMBLY P/N SD0521800

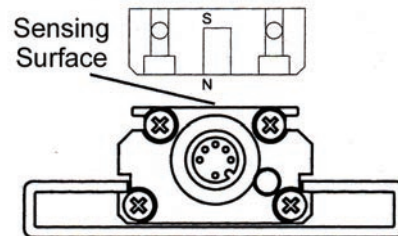
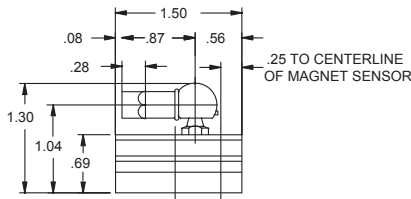
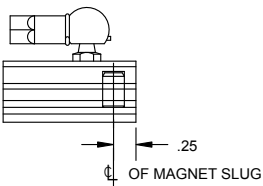

Note: The North Pole of the magnet should be pointed towards the probe.



Chapter 3 955D Outputs

3.1 CP (Control Pulse)

The Control Pulse signal interface of the BRIK digital output series is a differential RS-422 output. The maximum cable length for the differential digital LDT's is 1,500 feet. To initiate a start pulse, an external device is used. This start pulse should be 1.0 microsecond in duration. After the start pulse is received, the LDT will generate a stop pulse of 1.0 microsecond in duration. The time between the leading edge of the start pulse to the leading edge of the stop pulse is proportional to the distance from the Null Zone to the Magnet. The order of these two pulses is illustrated in the Figure 3-1. To wire the 955D-CP, see Figure 3-6. For proper grounding information, see Section 3.4.

Figure 3-1 955D-CP

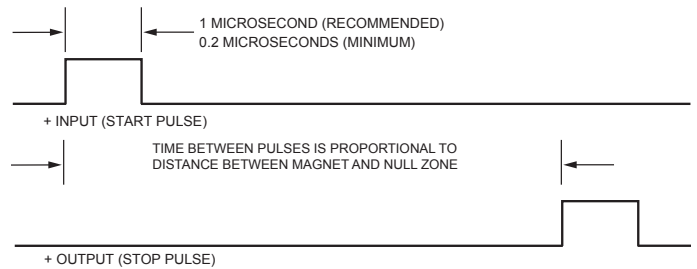

3.2 VP (Variable Pulse)

The Variable Pulse signal interface of the BRIK digital output series is a pulse width modulated signal (RS-422). The maximum cable length for the differential LDT's is 1,500 feet. This LDT can also be configured for external or internal interrogation. External interrogation is when an external device connected to the LDT generates a start pulse. This start pulse should be a minimum of 1.0 microsecond in duration. Within 50 nanoseconds after the leading edge of the start pulse has been received, the LDT will generate an output pulse. The duration of the output pulse is proportional to the distance from the Null Zone to the Magnet. The order of these two pulses is illustrated in Figure 3-2. The 955D-VP can also generate internal interrogations. This LDT will continually output pulse width modulated signals. As with a 955D-VP using an external interrogation, the duration of this output pulse is proportional to the distance from the Null Zone to the Magnet. This is illustrated in Figure 3-3. To wire the 955D-VP, see Figure 3-6. For proper grounding information, see Section 3.4.

Figure 3-2 955D-VP with External Interrogation

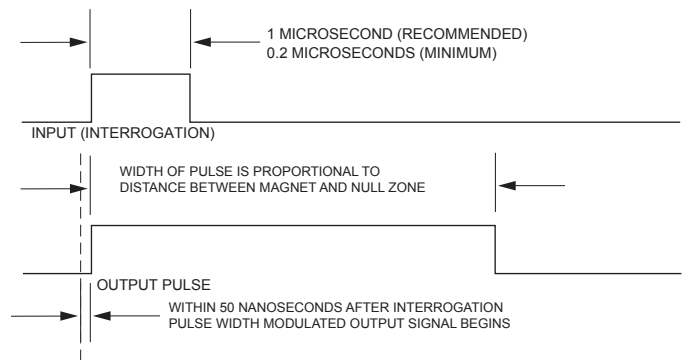
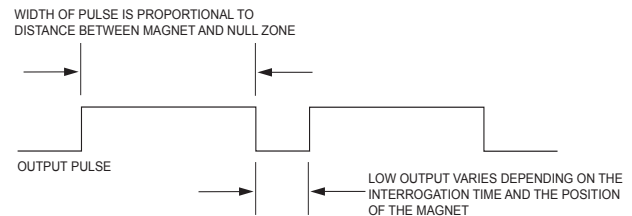

Figure 3-3 955D-VP with Internal Interrogation



Recirculations

The method used to improve the resolution of a system using a digital LDT. The "on" Time of a pulse width output is multiplied by a specific factor (from 1-127). This multiplication provides more counting time for the counter in the customer's electronics, thus improving the resolution. The only disadvantage to the higher recirculation numbers is the time needed to process the signal.

3.3 RS (Start/Stop)

The Start/Stop signal interface of the BRIK digital output series is differential RS-422 output. The maximum cable length for differential LDT's is 1,500 feet. To initiate a start pulse, an external device is used. This start pulse should be a minimum of 1.0 microsecond in duration. Within 50 nanoseconds after the leading edge of the start pulse, the LDT will generate a start pulse of 1.0 microsecond in duration. A stop pulse of 1.0 microsecond in duration will follow. The time it takes from the leading edge of the start pulse to the leading edge of the stop pulse is proportional to the distance from the Null Zone to the Magnet. The order of these two pulses is illustrated in Figure 3-4. To wire the 955D-RS, see Figure 3-6. For proper grounding information, see Section 3.4.

Figure 3-4 955D-RS

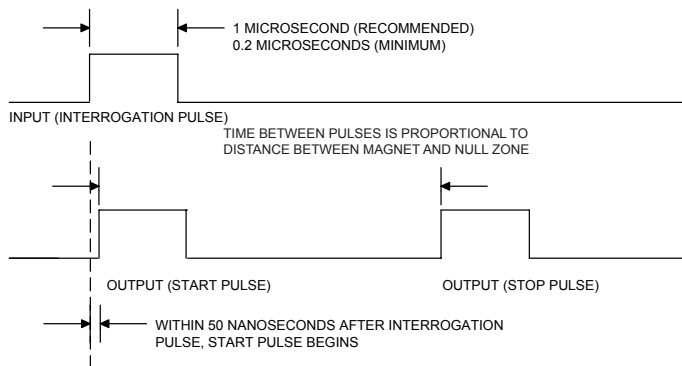

3.4 955D Wiring Connections

Once the LDT has been installed, wiring connections can be made. There are two groups of connections you will need to make. They are as follows:

- Power Supply Connections (including ground and shield)
- LDT Input/Output Connections

Power Supply/Ground Connections

The 955D standard cable is a 6 Pin, 12mm, Euro Style cordset. It has 6 conductors of 24ga, with an aluminum/polyester/aluminum foil with drain wire plus an overall

braid of tinned copper shield. Cable O.D. is .270. To reduce electrical noise, the shield must be properly used. Connect the cable's shield to the controller system GND. The connector shell on the probe is electrically connected to the probe housing.

Always observe proper grounding techniques such as single point grounding and isolating high voltage (i.e. 120/240 VAC) from low voltage (13.5-30 VDC cables). Whenever possible, this cable should be run in conduit by itself. The power supply common, the cable shield and a good earth ground should be connected together at the location of the power supply common.

WARNING

Do not route the BRIK output cable near high voltage sources.

In order for the 955D to operate properly, the LDT's external power supply must provide a voltage between +13.5 to +30 VDC. The power supply must be rated at 150mA minimum. The power supply should provide less than 1% ripple and 10% regulations. (The power supply should be dedicated to the LDT to prevent noise from external loads from affecting the BRIK.)

Figure 3.5 Power Supply Wiring

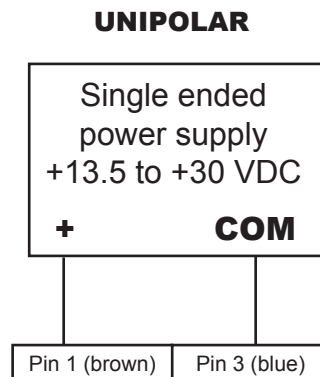
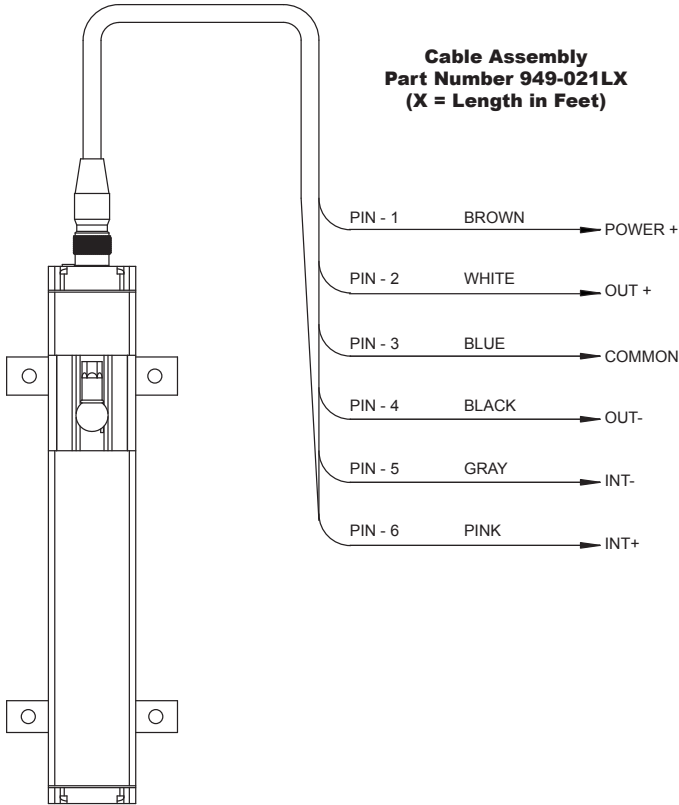
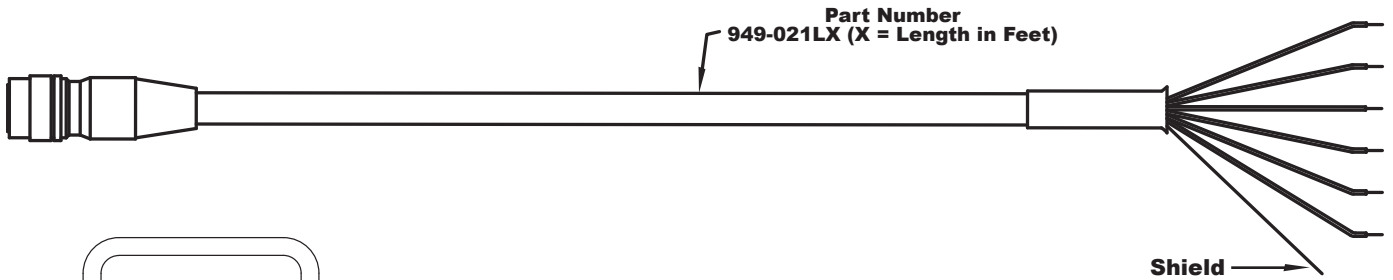



Figure 3.6 Wiring Diagram



3.5 Features

Automatic Gain Control

The Automatic Gain Control feature will automatically search and find the magnet on power up, if power is applied without a magnet on the LDT, the LED will turn RED indicating no magnet signal is detected. Turn power off and place magnet within the active stroke area. Re-apply power.

When using the Floating Magnet assembly (SD0522100), the magnet should be installed within 3/8" of the sensing surface. The magnet assembly should also be installed so that it remains an even distance from the aluminum extrusion throughout the entire stroke. Improperly installed magnets can result in output signal non-linearity.

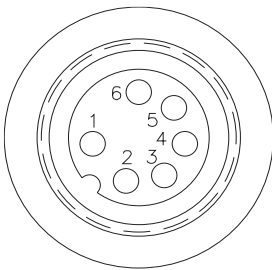

6 PIN CONNECTOR
LDT CONNECTOR VIEW

WIRE COLOR	6 PIN EURO. CONN. DESIG.	PIN OUT
BROWN	1	PWR+
WHITE	2	OUT+
BLUE	3	COMMON
BLACK	4	OUT-
GRAY	5	INT-
PINK	6	INT+

LED Colors

LED Color	Description
Green	Magnet is present and within the active programmed range.
Red	Fault, the LDT has lost its signal from the magnet or the magnet has moved into the Null Zone or Dead Band.
Yellow	No external interrogation signal detected.



3.6 Troubleshooting for 955D

Troubleshooting describes common problems that may occur when installing the LDT and offers possible solutions to these problems. If, after reading this appendix, you are unable to resolve a problem, contact our technical support department at 1-800-635-0289.

General Checks

Make sure that the magnet is located within the LDT's active stroke area. Captive magnet assemblies should be positioned so that they can move freely over the entire area of the active stroke without binding or pushing on the extrusion. Non-captive magnet assemblies should be situated so that the magnet is no further than 3/8" from the sensing surface at any point in the floating magnet assembly's movement.

Note: Ferromagnetic material (material readily magnetized) should be located no closer than 0.25" from the sensing surface of the LDT. This includes mounting brackets, magnet spacers, magnet brackets, and mounting screws. Ferromagnetic material can distort the magnetic field, causing adverse operation or failure of the LDT.

Check all LDT wires for continuity and/or shorts. It is preferable that the cable between the LDT and the interface device be one continuous run. If you are using a junction box, it is highly recommended that the splice junction box be free of AC and/or DC transient-producing lines. The shield should be carried through the splice and terminated at the interface device end.

Power Supply Check

This section will help you to determine if your power supply is adequate for the LDT to operate properly, or if the LDT's cable has a short or open.

In order for the 955D to operate properly, the external power supply must provide a level between 13.5 to 30 VDC. A power supply providing voltage above this specified range may damage the LDT. A power supply providing power below this specified range will not be sufficient to power the LDT. When powering more than one BRIK on a single power supply, remember that each BRIK requires 2.5 watts of power maximum. The amount of current draw will vary based on the input voltage used. To calculate the current draw for a particular LDT, divide

the LDT wattage by the input voltage. For example, 2.5 watts divided by 24 VDC equals 105mA.

If your LDT is not operating properly, the LDT's cable may have an open or short, or the power supply is not supplying sufficient power. To verify this, perform the following steps:

1. Turn the power supply off.
2. Remove the mating connector from the LDT.
3. Turn the power supply on.
4. Using a digital voltmeter, check pins 3 (GND) and 1 (+) from the mating end of the cable for a level between +13.5 and +30 VDC.

If reading is between 13.5 and 30 VDC, turn power supply off and go to step 7. If reading is below 13.5 VDC, either your power supply is not providing enough power or the LDT's cable possibly has a short/open. Readings of no voltage or minimal voltage (less than 5 volts) may be due to short/open in the cable. If reading is **NOT** between 13.5 and 30 VDC, go to step 5. If reading is above 30 VDC, adjust power supply or replace.

5. Turn the power supply off.
6. Check the continuity of the individual wires of the cable between the power supply and the LDT. Check for continuity from one end of the cable to the other. Also verify that no shorts exist between pins.
7. Reconnect the mating connector to the LDT.
8. Turn power supply on.
9. Using a digital voltmeter, check the power supply's "+" and "-" terminals for a voltage between 13.5 and 30 VDC.

Low voltage readings may indicate a power supply with a wattage (current) rating that is too low. (Each LDT requires 2.5 watts). If the cabling checks out in step 6 and your voltage is below 13.5 VDC, check your power supply current rating. If voltage is between 13.5 to 30 VDC and the LDT is still inoperative, contact factory.



3.7 Catalog Numbering System

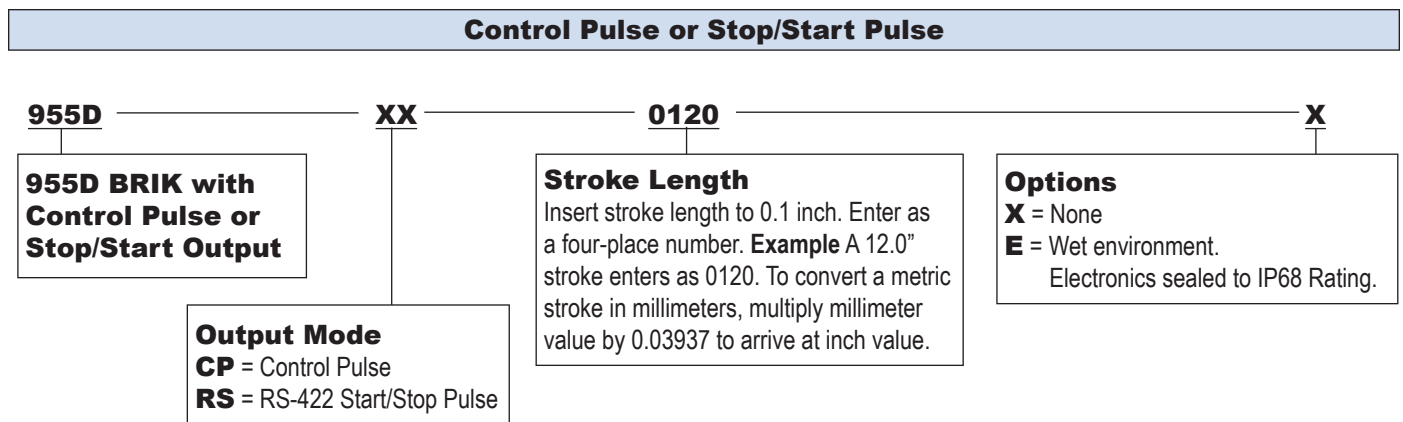
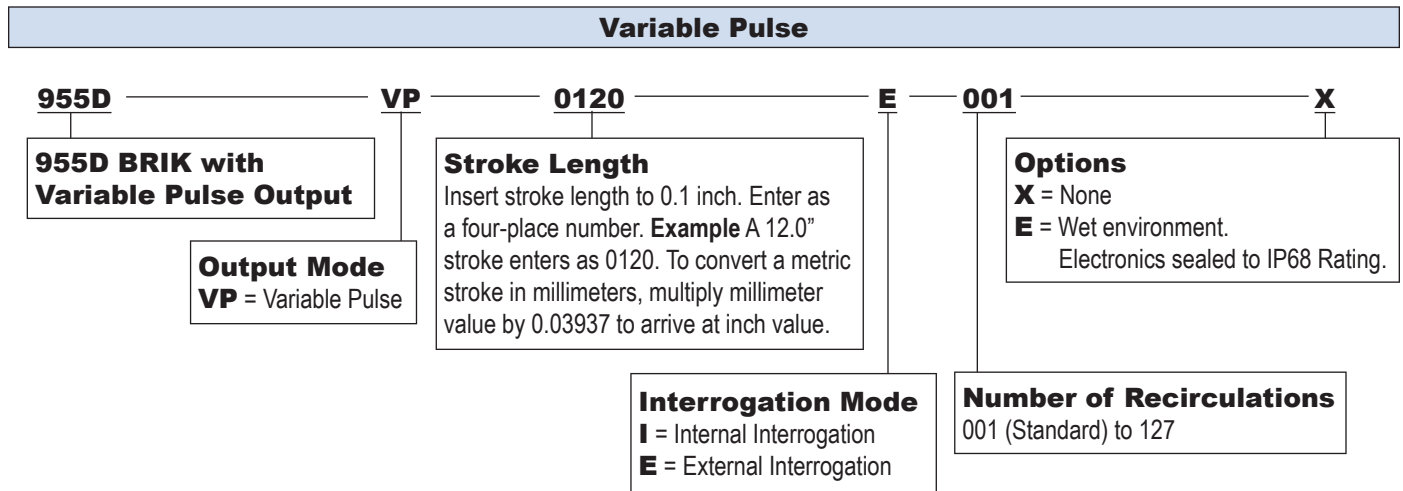

Note: Contact our Technical Support at 1-800-635-0289 for custom configurations.

3.8 Specifications for 955D

General Specifications	
Null Zone	3.00"
Dead Band	2.00"
Extrusion Assembly	Anodized Aluminum with gasket seals, IP 67, IP 68 Optional
Connector	6 Pin, 12mm Euro Style Connector
Sensor Length	5" to 180"
Agency Approval	CE
Shock & Vibration	
Random Vibration	MIL-STD 810E, 10Grms random, 20Hz - 2K Hz
Shock	Tested to 40G

Electrical Specifications	
Input Voltage	Unipolar 13.5 to 30 VDC
Current Draw	2.5 watts maximum
Nonlinearity	+/- 0.05% of full stroke
Repeatability	+/- 0.006% of full stroke
Hysteresis	+/- 0.02% of full stroke
Operating Temperature	-20° to 70° C
Storage Temperature	-40° to 85° C
Update Time	Controller Dependent
Specifications are subject to change and are based on a typical 36" LDT.	

3.9 Accessories

**Slide Magnet Assembly
Part Number SD0521800**

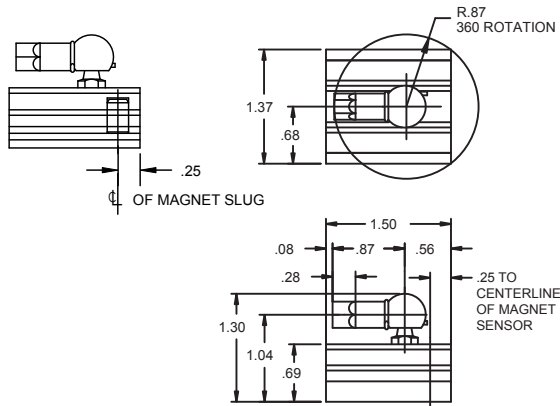

**Floating Magnet Assembly
Part Number SD0522100**

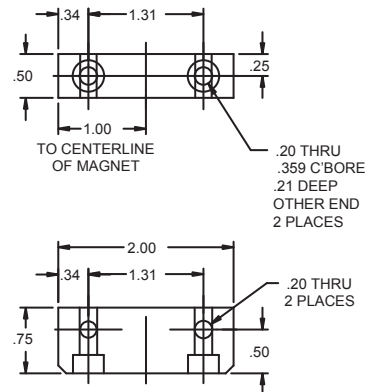

**Mounting Foot
Part Number SD0522000**

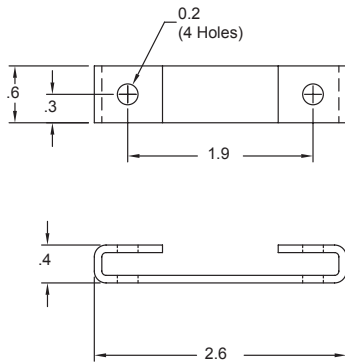

**6 Pin Micro 12mm Euro Straight Cable
Part Number 949-021LXX**

X = Length in Feet

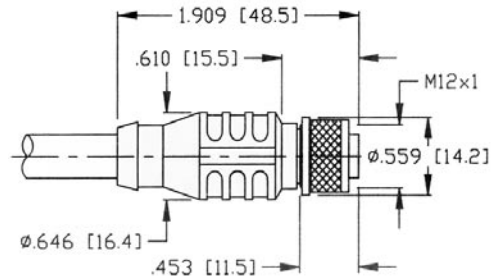

**6 Pin Micro 12mm Euro Right Angle Cable
Part Number 949-022LXX**

X = Length in Feet

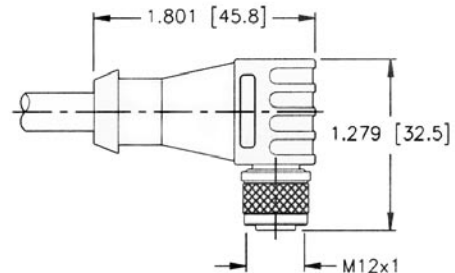



955D Glossary

Active Stroke Area	The area on the extrusion between the Null Zone and Dead Band on which the magnet assembly moves.
Dead Band	An area usually 2.0" from the end of the extrusion where sensing of the magnet is not possible.
Floating Magnet	A non-ferrous assembly that contains the magnet that moves across the LDT's sensing surface in a non-contact manner.
External Device	A device wired to the LDT which generates external interrogations.
External Interrogations	Pulses sent from an external device to the LDT, usually to initiate a pulse sequence.
Null Zone	An area usually covering 3.00" on the extrusion beginning at the connector end.
LDT	Linear Displacement Transducer.
RS-422 Differential	Differential line driver.
Slide Magnet Assembly	A non-ferrous assembly that moves across the LDT's sensing surface.
Unipolar	A power supply that provides a single voltage.
Wire Speed	The average time it takes a pulse to travel one inch on the LDT's wire.
Recirculations	The method used to improve the resolution of a system using a digital LDT. The "on" Time of a pulse width output is multiplied by a specific factor (from 1-127). This multiplication provides more counting time for the counter in the customer's electronics, thus improving the resolution. The only disadvantage to the higher recirculation numbers is the time needed to process the signal.
Return (Stop) Pulse	A pulse generated by the BRIK to determine the location of the magnet assembly on the extrusion.
Start Pulse	A pulse generated by either an external device or the LDT to start a pulse sequence.
Stop Pulse	(See Return Pulse)



Other Products

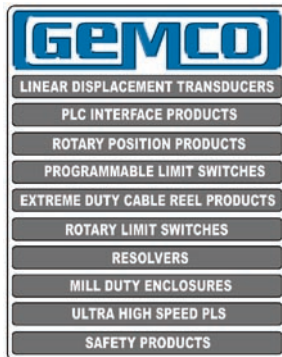

Copyright 2004 by AMETEK AUTOMATION & PROCESS TECHNOLOGIES.
All Rights Reserved. Made in the USA.



1080 N. Crooks Road, Clawson, MI 48017-1097
Phone 248-435-0700 Toll Free 800-635-0289
Fax 248-435-8120 www.AMETEKAPT.com

955D.M1RO
10/04.Z167
250

