

955 Series



INSTALLATION MANUAL

LINEAR DISPLACEMENT TRANSDUCERS

955S BRIK™

Smart BRIK LDT

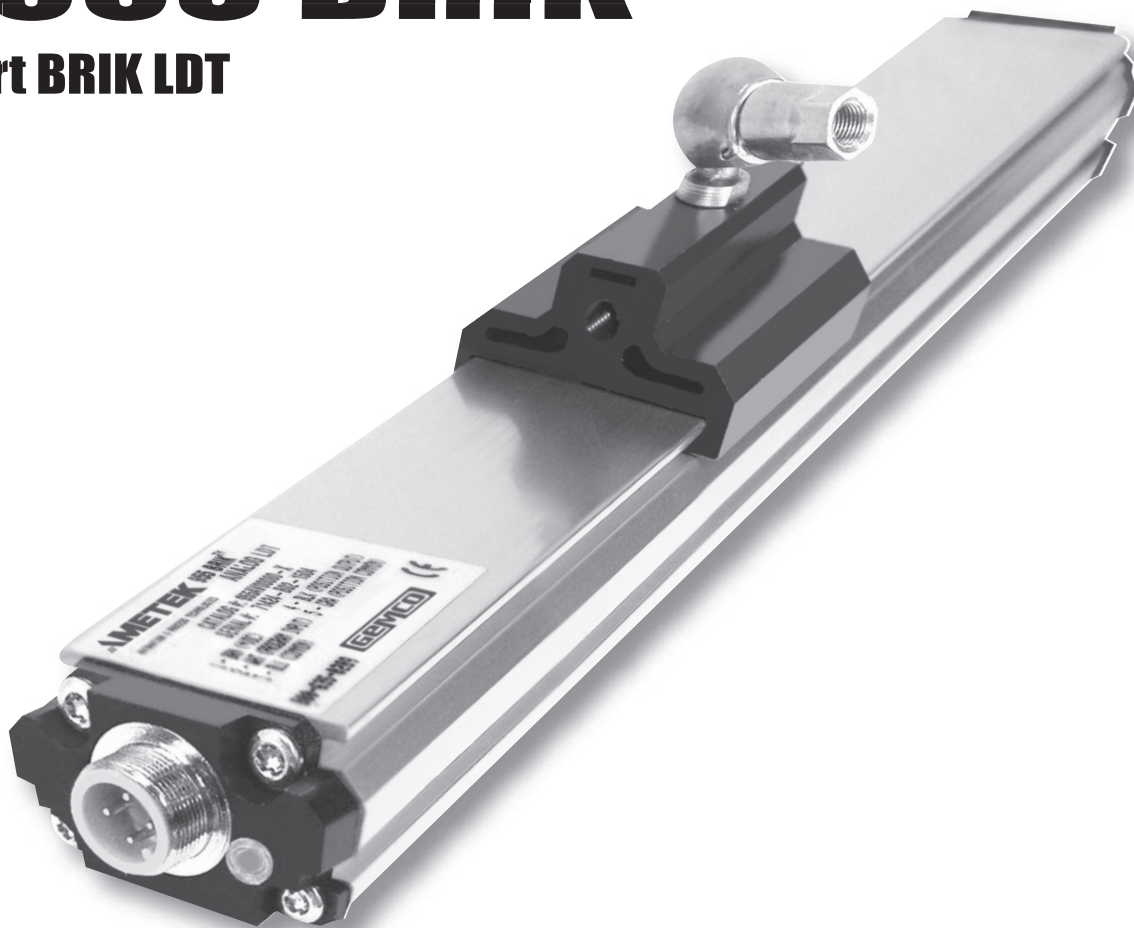

**ABSOLUTE PROCESS CONTROL
KNOW WHERE YOU ARE... REGARDLESS**



Introduction

The 955S Smart Brik is an accurate programmable, auto-tuning, non-contact, linear displacement transducer in an economical, low profile package. The transducer utilizes our field proven magnetostrictive technology to give absolute position, repeatable to .01% of the programmable sensing distance. The streamlined anodized aluminum extrusion houses the sensing element and electronics. The magnet moves over the sensing element that determines the position and converts it to an analog output. It can be ordered with various outputs:

- 0 to 10 VDC
- 10 to 10 VDC
- 0 to 5 VDC
- 5 to 5 VDC
- 4 to 20mA

The 955S Smart Brik has a few truly unique features. The first one being the LDT's auto-tuning capability, the ability to sense a magnet other than the standard slide magnet and adjust its signal strength accordingly. Another feature is the analog output is programmable over the entire active stroke length. The active stroke area of the LDT lies between the Null Zone and Dead Band.

There is a diagnostic LED located at the connector end of the probe that remains green while a good magnet signal is present and when the magnet is in the programmed stroke area. The LED turns yellow when the magnet is out of the programmed active range, but still within the active stroke area. The LED turns red and the output goes to 0 volts on voltage output units, or 4mA on current output units when there is no magnet present or when the magnet is out of the sensing area. The unit can easily be changed in the field.

| From | To |
|---------------|---------------|
| 0 to 10 VDC | 10 to 0 VDC |
| -10 to 10 VDC | 10 to -10 VDC |
| 0 to 5 VDC | 5 to 0 VDC |
| -5 to 5 VDC | 5 to -5 VDC |
| 4 to 20mA | 20 to 4mA |

NOTE 1: As an added benefit, the 955S is FM approved for Class I, Div II, Groups A, B, C, D applications when installed and wired per drawing E0241100.

NOTE 2: If your application does not require FM Class I, Div II approval, wire the 955S using a standard 4 pin Euro cordset from Ametek or others.

Mounting

The transducer can be mounted vertically or horizontally using SD0522000 Mounting Brackets. The mounting brackets slide in the grooves on the lower part of the extrusion and clamp down when tightened. It is recommended to use one mounting bracket on each end and every three feet between.

NOTE: If using the floating magnet option, you must set the automatic gain control.

Ferro-magnetic material, (material readily magnetized) should be placed no closer than .25" from the sensing surface of the LDT.

LED Colors

Green: Magnet is present and within the active programmed range.

Red: Fault, the LDT has lost its signal from the magnet or the magnet has moved into the Null Zone or Dead Band.

Yellow: Magnet is out of the programmed ZERO to SPAN range.

Setting Zero & Span Positions

The Series 955S is programmable over the entire active stroke length of the LDT. Keep in mind that there is a 3" Null area at the connector end of the LDT and a 1.5" Dead area at the other end of the LDT that the magnet must stay out of at all times. The diagnostic LED can help aid you in the setup of the Zero and Span. A green or yellow LED means that it is OK to program the LDT in this area, a red LED means that the LDT cannot be programmed in this area.

To set the ZERO and SPAN position for the probe follow these steps:

1. Power up the probe in normal operating mode (i.e. "PRGM" pin floating)
2. Place magnet assembly where ZERO is to be located, but within the active region of probe
3. Momentarily short "PRGM" pin (pin 2) to ground (pin 3)
4. Place magnet assembly where SPAN is to be located, but within the active region of the probe
5. Momentarily short "PRGM" pin (pin 2) to V+ (pin 1)

NOTE 1: AGC should be set first before setting the ZERO and SPAN positions when using a floating magnet.

NOTE 2: SPAN could also be set first, followed by setting the ZERO position.



NOTE 3: ZERO or SPAN can be adjusted individually without setting the other.

NOTE 4: ZERO = 0V on 0 to 10 VDC units and 4mA on 4 to 20mA units.

For your convenience, Ametek offers an in-line programming unit (955-1409) that can be installed in-line with the LDT. The in-line programmer uses a rocker switch to program the zero and span. For details, see accessories on page 7.

Automatic Gain Control

The Automatic Gain Control feature is only used when sensing a magnet other than the standard SD0521800 slide magnet. If you are using the standard slide magnet skip to Setting Zero and Span Position.

When using the Floating Magnet assembly (SD0522100), the magnet should be installed within 3/8" of the sensing surface. The magnet assembly should also be installed in such a manner that it remains an even distance from the aluminum extrusion throughout the entire stroke. Improperly installed magnets can result in output signal non-linearity.

To set the Automatic Gain Control (AGC) level for the probe follow these steps:

1. Place magnet assembly close to the Dead Band (but within the active region) of the probe
2. Power down the probe
3. Short "PRGM" pin (pin 2) to ground (pin 3)
4. Apply power to probe
 - A. The LED flashes RED indicating it is in the AGC mode.
 - B. The LED will change to flashing GREEN when it has determined the proper AGC level and has saved it to non-volatile memory.

NOTE: When the probe is in AGC mode, the output will be at either 0 volts or 4mA, depending on the model that was ordered.

The AGC is now complete.

To place the probe back into the normal operating mode follow these steps:

1. Power down the probe
2. Remove short from "PRGM" pin
3. Apply power to the probe

The probe is now in the normal operating mode.

NOTE: The north pole of the magnet should be pointed towards the probe.

| Specifications | |
|--|--|
| Input Voltage | 10 to 30 VDC |
| Current Draw | 80mA @ 10 VDC |
| Voltage Units | 35mA @ 30 VDC |
| Current Units | 90mA @ 10 VDC |
| | 55mA @ 30 VDC |
| Output | 0 to 10 VDC -5 to 5 VDC 10 to 0 VDC 5 to -5 VDC -10 to 10 VDC 0 to 5 VDC 10 to -10 VDC 5 to 0 VDC 4 to 20mA 20 to 4mA |
| Linearity | +/- 0.05% of Stroke or +/- 0.028" whichever is greater |
| Accuracy | +/- 0.1% of Stroke or +/- 0.050" whichever is greater |
| Repeatability | +/- 0.01% of Full Stroke or +/- 0.014" whichever is greater |
| Update Time | |
| Stroke Length: | |
| 4" ≤ 50" | 1ms with 5ms settling time |
| 51" ≥ 100" | 2ms with 4ms settling time |
| 101" ≥ 150" | 3ms with 3ms settling time |
| 151" ≥ 180" | 4ms with 4ms settling time |
| Operating Temperature | -20° to 70° C |
| Span Length | 4" to 180" |
| Null Zone | 3.00" |
| Dead Band | 1.50" |
| LED | Green = Power is applied and magnet is present Red = Fault, magnet is in the Dead Band or lost Yellow = Out of the active programmed range |
| Connector | Standard 4 Pin Micro 12mm Euro Connector |
| Approvals | CE FM - When installed per drawing E0241100 |
| Enclosure | IP67, IP68 Optional |
| Output Load | |
| Voltage Output | 1KΩ (1.5KΩ for +/- 10V) (minimum) |
| Current Output | (Vin - 4) / 20mA (maximum) |
| Specifications are subject to change without notice. Specifications are based on a typical 36" LDT. | |



955S Wiring Connections

Once the LDT has been installed, wiring connections can be made. There are two groups of connections you will need to make. They are as follows:

- Power Supply Connections (including ground and shield)
- LDT Input/Output Connections

Power Supply/Ground Connections

The 955S standard cable is a 4 Pin, 12mm, Euro Style cordset. It has 4 conductors of 22ga, with an aluminum/polyester/aluminum foil with drain wire. Cable O.D. is .250. To reduce electrical noise, the shield must be properly used. Connect the cable's shield to the controller system GND.

Always observe proper grounding techniques such as single point grounding and isolating high voltage (i.e. 120/240 VAC) from low voltage (10-30 VDC cables). Whenever possible, this cable should be run in conduit by itself. The power supply common, the cable shield and a good earth ground should be connected together at the location of the power supply common.



WARNING

Do not route the BRIK output cable near high voltage sources.

In order for the 955S to operate properly, the LDT's external power supply must provide a voltage between +10 to +30 VDC. The power supply must be rated at 100mA minimum. The power supply should provide less than 1% ripple and 10% regulations. (The power supply should be dedicated to the LDT to prevent noise from external loads from affecting the BRIK.)

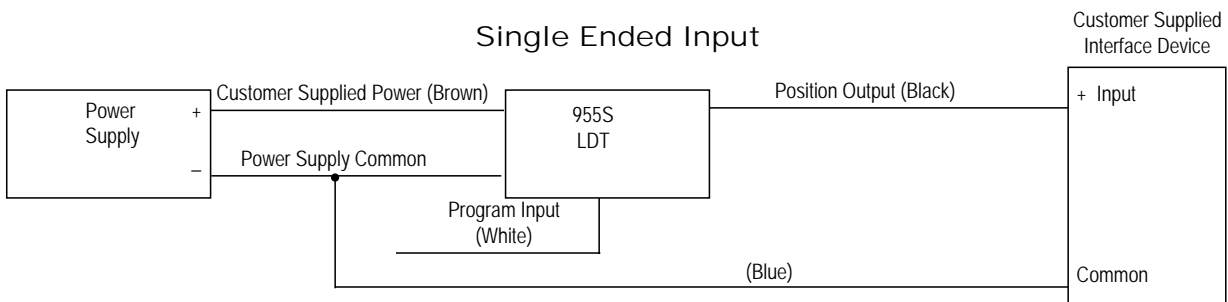
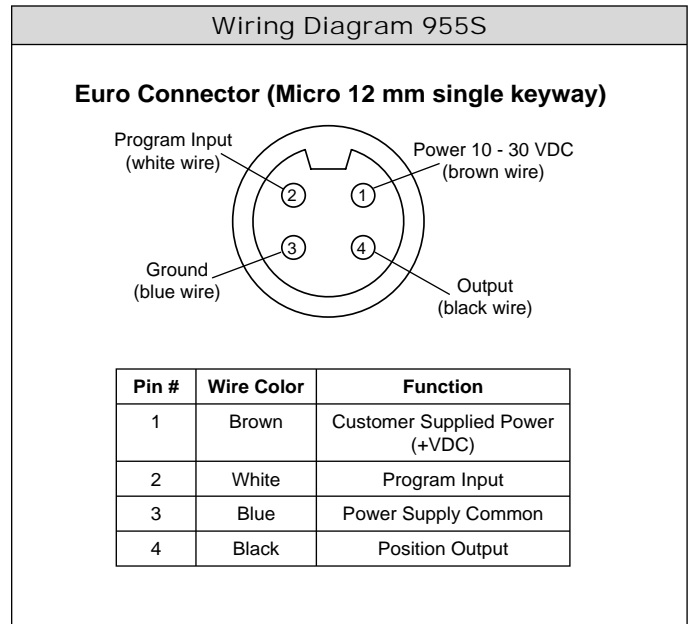

NOTE: 955S-C is current sourcing, which allows the current to flow from the LDT into the user's equipment.

Dimensions

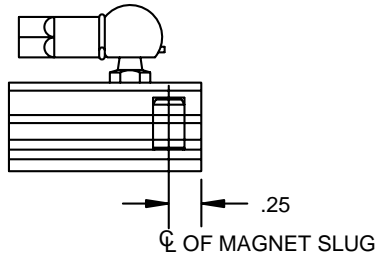

A standard female swivel mounting arm is provided with the slide magnet assembly. For extensions and other options contact the factory.

Mounting brackets (SD0522000) slide in the grooves on the side of the extruded housing. When tightened down with fastening hardware the mounting brackets clamp the unit into place. It is recommended to use one mounting bracket on each end and every three feet between.

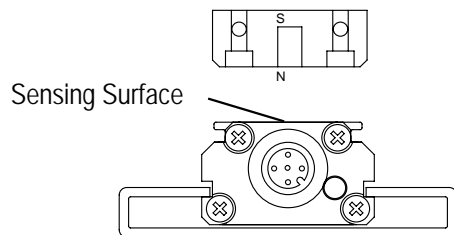
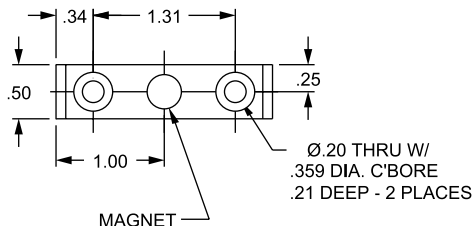
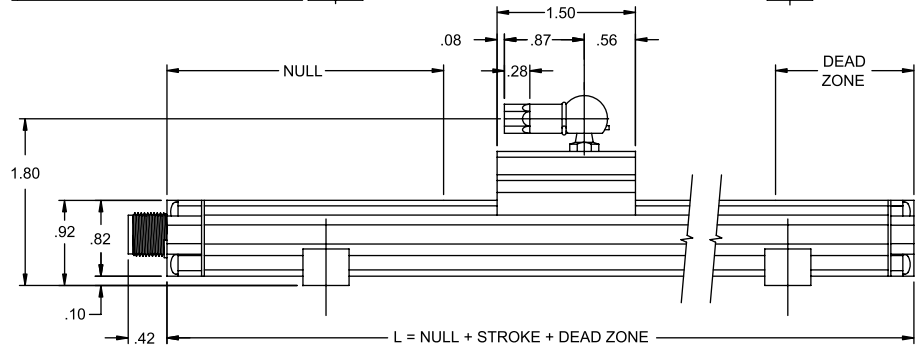
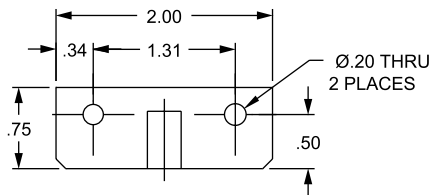
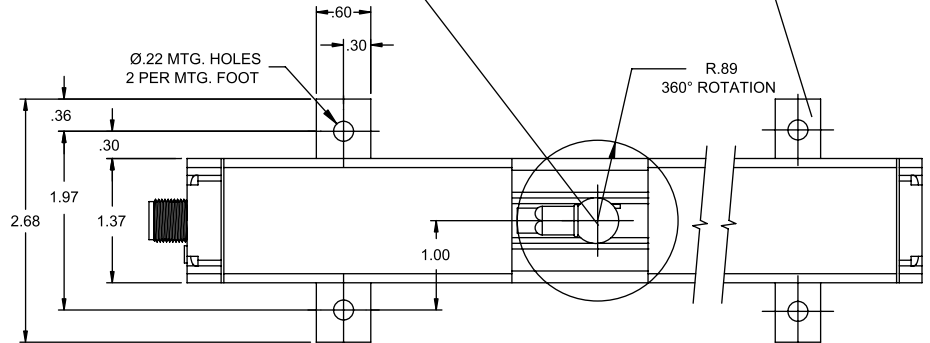

Floating Magnet Assembly (SD0522100)

NOTE 1: The north pole of the magnet should be pointed towards the probe.

NOTE 2: If using the Floating Magnet Assembly option, you must set Automatic Gain Control. See page 3.

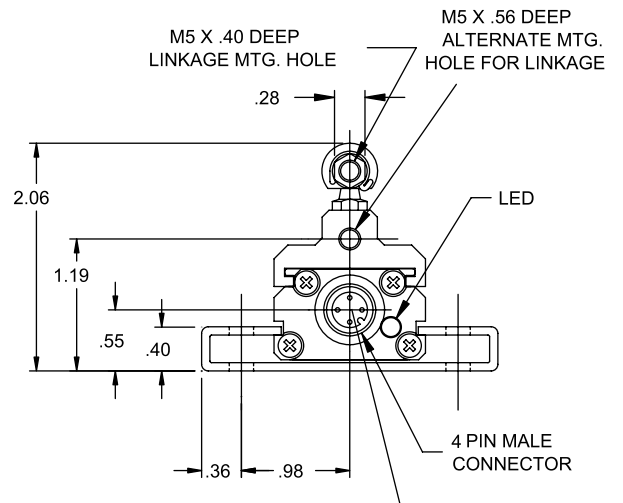

A standard 12 mm 4 pin micro connector is used. Straight mating cables can be ordered in a 6' length, or 12' length. If space is a consideration a right angle connector is also available.

WARNING

Do not use cord sets with LED's



FM Approved for Class I, Div II

NOTE 1: As an added benefit, the 955S is FM approved for Class I, Div II, Groups A, B, C, D applications when installed and wired per drawing E0241100.

NOTE 2: If your application does not require FM Class I, Div II approval, wire the 955S using a standard 4 pin Euro cordset from Ametek or others.

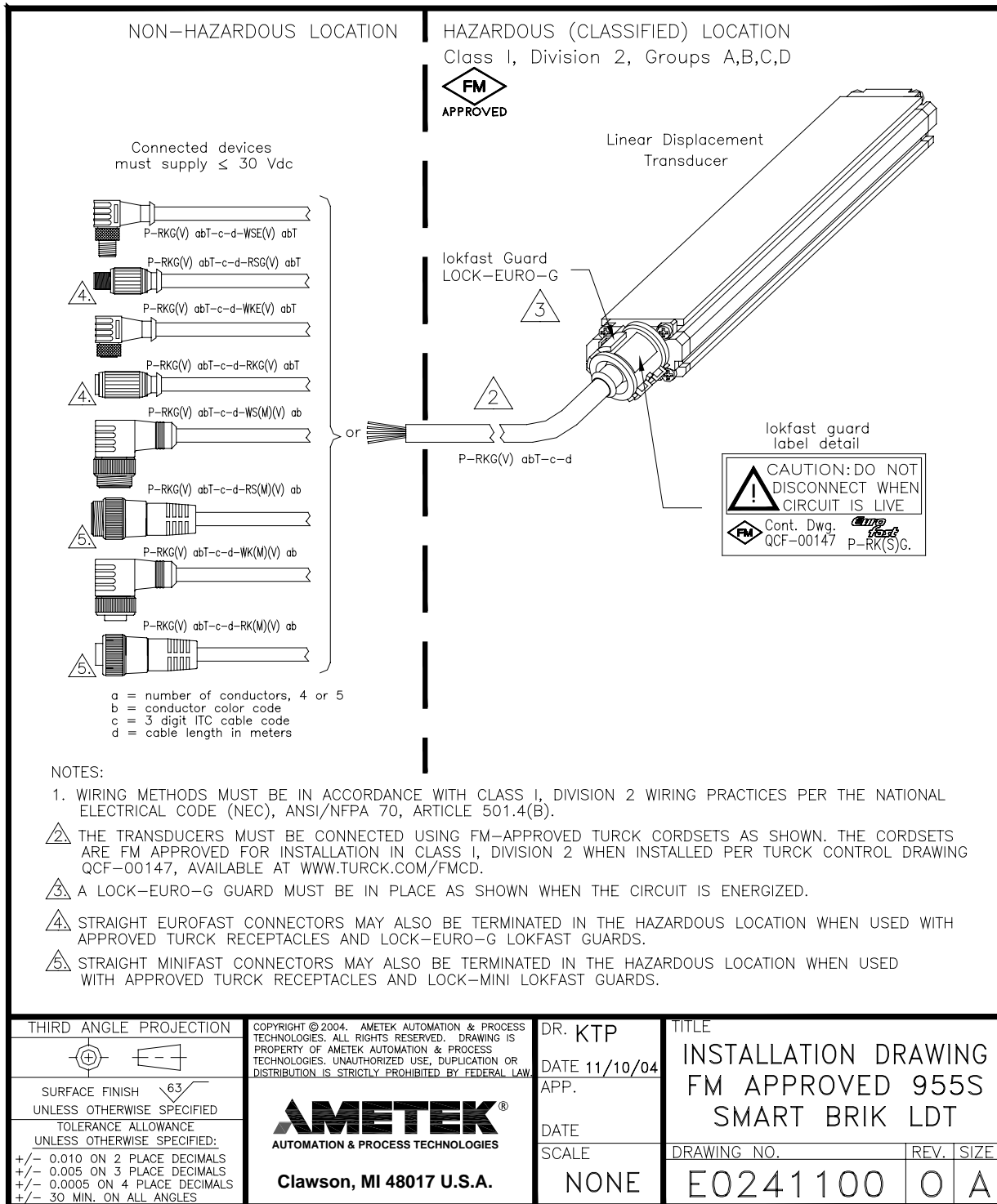



| Accessories | |
|--|-----------------------|
| Item | Part Number |
| Slide Magnet | SD0521800 |
| Slide Magnet Side Adapter | SD0521801 |
| Float Magnet | SD0522100 |
| Mounting Foot | SD0522000 |
| 6 Ft. Cable | 949001L6 |
| 12 Ft. Cable | 949001L12 |
| 6 Ft. Cable, Right Angle Connector | 949002L6 |
| 12 Ft. Cable, Right Angle Connector | 949002L12 |
| Control Arm | 955ARMXX (X = Inches) |
| In-Line Programming Unit | 955-1409 |
| Rod Ends | 04-570252 |
| FM Accessories | |
| 6 Ft. Straight Cable | 949024L6 |
| 12 Ft. Straight Cable | 949024L12 |
| Connector Lock | 04-521570 |
| NOTE: FM approved cordset and connector lock must be used and installed per drawing E0241100 when installing the 955S in Class I Div II, Group A, B, C, D applications. | |

Float Magnet P/N SD0522100



Slide Magnet P/N SD0521800



Slide Magnet Side Adapter P/N SD0521801



In-Line Programming Unit P/N 955-1409



Control Arm P/N 955ARMXX



Rod Ends P/N 04-570252



Mounting Foot P/N SD0522000



Part Numbering

955S

955S
Smart BRIK

XX

Output
 V0 = 0 to 10 VDC
 V1 = 10 to 0 VDC
 V2 = -10 to 10 VDC
 V3 = 10 to -10 VDC
 V4 = 0 to 5 VDC
 V5 = 5 to 0 VD
 V6 = -5 to 5 VDC
 V7 = 5 to -5 VDC
 C2 = 20 to 4mA
 C4 = 4 to 20mA

XXXX

Stroke Length
 Insert stroke in inches to 0.1 inch. Enter as a four-place number. Valid lengths are 0040 to 1800. **Example:** 12.0 inch probe stroke is entered as 0120. To convert a metric stroke in millimeters, multiply millimeter value by 0.03937 to arrive at inch value.

X

Options
 Leave blank for no options.
 E = Wet environment. Electronics sealed to IP 68 Rating.



Other Products

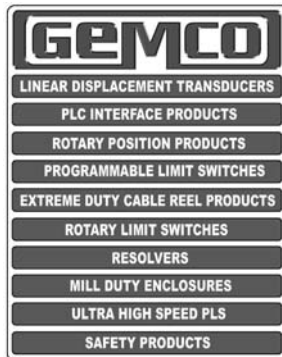

Copyright 2005 by AMETEK AUTOMATION & PROCESS TECHNOLOGIES.
All Rights Reserved. Made in the USA.



1080 N. Crooks Road, Clawson, MI 48017-1097
Phone 248-435-0700 Toll Free 800-635-0289
Fax 248-435-8120 www.AMETEKAPT.com

955S.M3R
6/05.Z141

