

HITACHI INVERTER

SJ100 SERIES

SERVICE MANUAL

(ADJUSTMENT AND MAINTENANCE)

Model:

European Version

SJ100-002NFE to SJ100-022NFE

SJ100-004HFE to SJ100-075HFE

US Version

SJ100-002NFU to SJ100-022NFU

SJ100-004HFU to SJ100-075HFU

SJ100-037LFU

Japanese Version

SJ100-002LFR to SJ100-037LFR

SJ100-004HFR to SJ100-075HFR

After reading this manual, keep it at hand for future reference

Hitachi, Ltd.

Tokyo Japan

NBS585XA

INDEX

1. Pre-operation Check	1-1
1-1. Check inverter model and Manufacturing number	1-1
1-2. Check inverter parameter and motor specification	1-2
2. Measurement of The Internal Voltage Supply	2-1
3. Trouble Shoot	3-1
3-1. Error messages - Possible Cause and Remedy	3-1
3-2. Analysis of Various Operating Problems That Do Not Trigger an Trip Message	3-7
3-3. How to Initialize the Data (FACTORY SETTING)	3-8
3-4. Error Message Comparison	3-9
3-5. Other Displays	3-10
3-6. Auto tuning under high incoming voltage	3-10
4. Ambient Condition of the Frequency Inverter (Temperature, Altitude)	4-1
4-1. Required Derating in case of 50deg., 55 deg. of Ambient Temperature	4-1
4-2. Required derating toward altitude	4-4
5. Level of Each Detection	5-1
5-1. DC Bus Voltage Detection Characteristics	5-1
5.2. Output Current Detection Characteristics	5-3
5.3. Motor Temperature Detection (PTC)	5-4
5.4. Over Temperature Detection of the Frequency Inverter	5-4
6. Measurement & Replacement of Subassemblies	6-1
6-1. Insulation Measurement	6-1
6-2. Power Components Measurements	6-1
7. Maintenance and Inspection Procedure	7-1
7-1. Precautions	7-1
7-2. Measurement of Mains Voltage, Current and Power	7-1
7-3. Maintenance of Parts	7-4
7-4. If you install replacement INV at site	7-4
8. Daily Inspection and Periodical Inspection	8-1
9. Image block diagram	9-1
10. Spare parts list	10-1
10-1. parts list	10-1
10-2. I/O board compatibility	10-13
10-3. O, OI terminal adjustment procedure (C81, C82)	10-14
10-4. kW setup procedure	10-15
10-5. I/O board schematic (circuit diagram)	10-16

Revisions

Revision history table

No.	Revision contents	Date of issue	Manual No.

1. Pre-Operation Check

Before starting adjustment and maintenance, be sure to check the following specifications of the inverter and the motor.

1.1 Check Inverter model and Manufacturing number (MFG No).

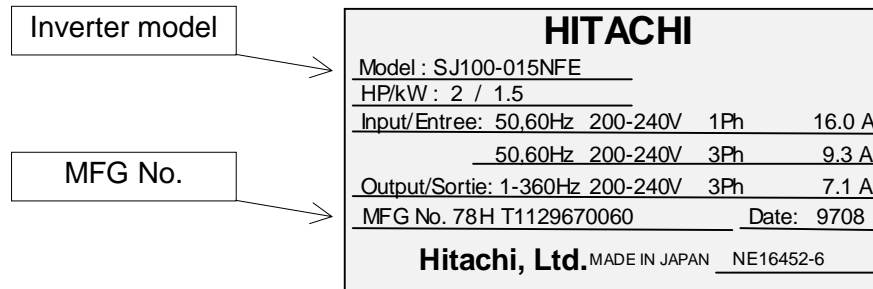

You can find these information from the specification label which attached at the side cover of the unit.

(1) Description of the model name.

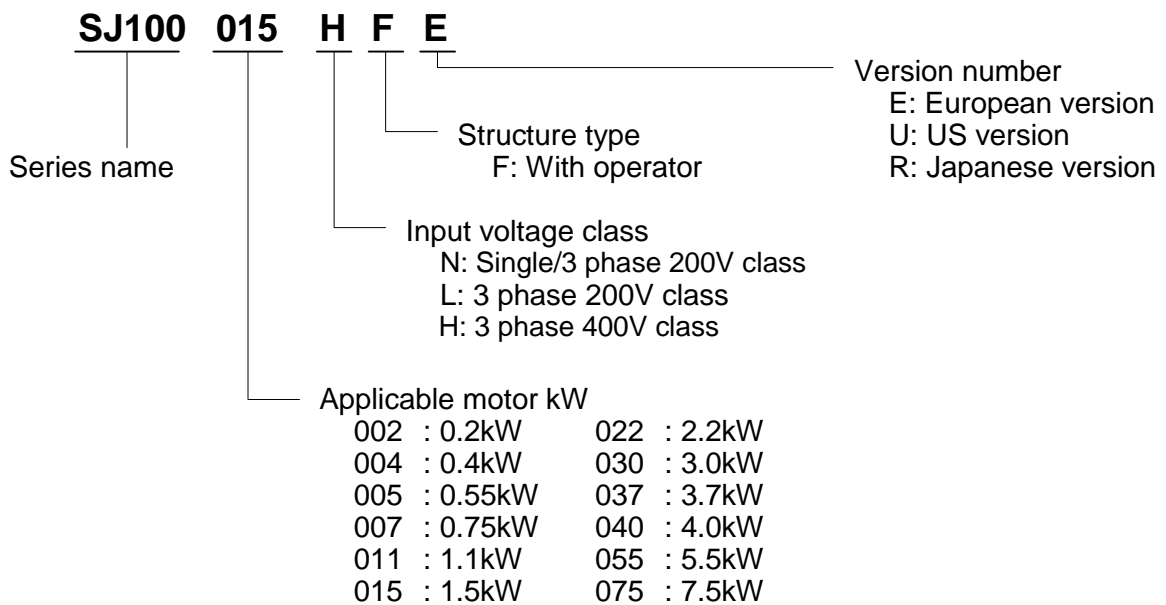

(2) Description of MFG No.

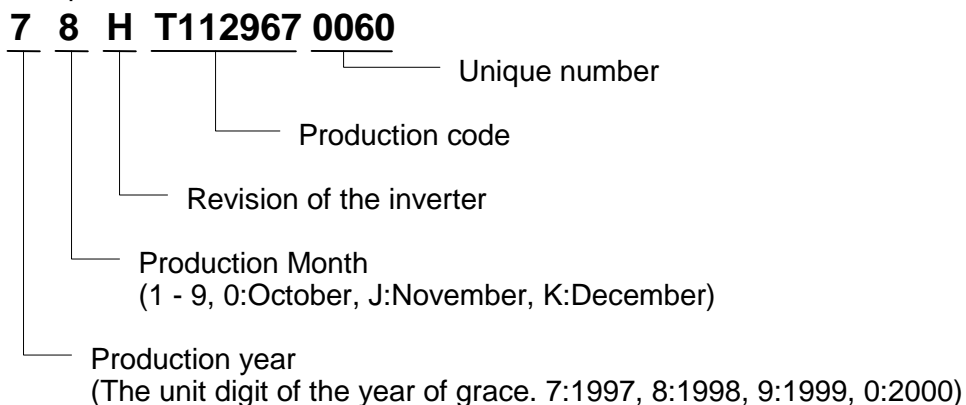

1.2 Check Inverter parameter and motor specification.

[1] Inverter specifications.

(1) Inverter specifications (Monitor mode)

Display order	Function name	Category	Screen display	Initial			Remarks
			Code display	EU	US	JPN	
1	Output frequency monitor	Monitor	d01	-	-	-	
2	Output current monitor	Monitor	d02	-	-	-	
3	Running direction monitor	Monitor	d03	-	-	-	
4	Feedback data of PID control monitor	Monitor	d04	-	-	-	
5	Intelligent input terminal condition monitor	Monitor	d05	-	-	-	
6	Intelligent output terminal condition monitor	Monitor	d06	-	-	-	
7	Output frequency converted value monitor	Monitor	d07	-	-	-	
8	Trip monitor	Monitor	d08	-	-	-	
9	Trip history monitor	Monitor	d09	-	-	-	

(2) Inverter specifications (Basic function mode)

Display Order	Function name	Category	Screen display	Initial			Remarks
			Code display	EU	US	JPN	
1	Output frequency setting	Set	F01	0.0	0.0	0.0	
2	Acceleration time 1	Set	F02	10	10	10	
-	Acceleration time 1 (2 nd setting)	Set	F202	10	10	10	
3	Deceleration time 1	Set	F03	10	10	10	
-	Deceleration time 1 (2 nd setting)	Set	F203	10	10	10	
4	Running direction setting	Set	F04	00	00	00	
5	Extended function A group setting	Set	A--				
6	Extended function B group setting	Set	B--				
7	Extended function C group setting	Set	C--				
8	Extended function H group setting	Set	H--				

Note; “-“ means hidden display ;depends on 2nd setting selection.

(3) Inverter specifications (Extended function mode : A group)

Display Order	Function name	Category	Screen display	Initial			Remarks
			Code display	EU	US	JPN	
1	Frequency destination	Set	A01	01	01	00	
2	Running command destination	Set	A02	01	01	02	
3	Base frequency	Set	A03	50	60	60	
-	Base frequency(2 nd setting)	Set	A203	50	60	60	
4	Maximum frequency	Set	A04	50	60	60	
-	Maximum frequency(2 nd setting)	Set	A204	50	60	60	
5	External freq. setting start	Set	A11	0	0	0	
6	External freq. setting end	Set	A12	0	0	0	
7	External freq. setting start rate	Set	A13	0	0	0	
8	External freq. setting end rate	Set	A14	100	100	100	
9	External freq. start pattern	Set	A15	01	01	01	
10	Time constant of the filter of analog input	Set	A16	8	8	8	

(3) Inverter specifications (Extended function mode : A group)

Display Order	Function name	Category	Screen display	Initial			Remarks
			Code display	EU	US	JPN	
11	Multi-speed 1 to 16	Set	A20 - A35	0	0	Note 1	
12	Jogging frequency	Set	A38	1.0	1.0	1.0	
13	Stop mode of jogging	Set	A39	00	00	00	
14	Torque boost mode	Set	A41	00	00	00	
-	Torque boost mode(2 nd setting)		A241	00	00	00	
15	Level of manual torque boost	Set	A42	11	11	11	
-	Level of manual torque boost (2 nd setting)		A242	11	11	11	
16	Manual torque boost frequency	Set	A43	10.0	10.0	10.0	
-	Manual torque boost frequency (2 nd setting)		A243	10.0	10.0	10.0	
17	V/f characteristics	Set	A44	00	00	00	
-	V/f characteristics(2 nd setting)		A244	00	00	00	
18	V-gain	Set	A45	100	100	100	
19	Selection of DC braking	Set	A51	00	00	00	
20	DC braking frequency	Set	A52	0.5	0.5	0.5	
21	DC braking waiting time	Set	A53	0.0	0.0	0.0	
22	DC braking force	Set	A54	0	0	0	
23	DC braking time	Set	A55	0.0	0.0	0.0	
24	Frequency upper limiter	Set	A61	0.0	0.0	0.0	
25	Frequency lower limiter	Set	A62	0.0	0.0	0.0	
26	Jump frequency 1-3	Set	A63, A65, A67	0.0	0.0	0.0	
27	Jump frequency width 1-3	Set	A64, A66, A68	0.5	0.5	0.5	
28	Selection of PID control	Set	A71	00	00	00	
29	P gain	Set	A72	1.0	1.0	1.0	
30	I gain	Set	A73	1.0	1.0	1.0	
31	D gain	Set	A74	0.0	0.0	0.0	
32	Scale conversion of PID control	Set	A75	1.0	1.0	1.0	
33	Feedback destination	Set	A76	00	00	00	
34	Selection of AVR function	Set	A81	02	02	02	
35	AVR voltage	Set	A82	230/400	230/460	200/400	
36	Second acceleration time	Set	A92	15.0	15.0	15.0	
-	Second acceleration time(2 nd setting)		A292	15.0	15.0	15.0	
37	Second deceleration time	Set	A93	15.0	15.0	15.0	
-	Second deceleration time(2 nd setting)		A293	15.0	15.0	15.0	
38	Method to use 2nd acceleration / deceleration (Acc2 / Dec2)	Set	A94	00	00	00	
-	Method to use 2nd acceleration / deceleration (Acc2 / Dec2)(2 nd setting)		A294	00	00	00	
39	Acc1 to Acc2 changing frequency	Set	A95	0.0	0.0	0.0	
-	Acc1 to Acc2 changing frequency(2 nd setting)		A295	0.0	0.0	0.0	
40	Dec1 to Dec2 changing frequency	Set	A96	0.0	0.0	0.0	
-	Dec1 to Dec2 changing frequency(2 nd setting)		A296	0.0	0.0	0.0	
41	Acceleration characteristic	Set	A97	00	00	00	
42	Deceleration characteristic	Set	A98	00	00	00	

Note 1; A20;0, A21;5, A22;10, A23;15,A24;20, A25;30, A26;40, A27;50, A28; 60,A29--A35;0

(4) Inverter specifications (Extended function mode : B group)

Display Order	Function name	Category	Screen display	Initial			Remarks
			Code display	EU	US	JPN	
1	Selection of restart mode	Set	B01	00	00	00	
2	Allowable UV time	Set	B02	1.0	1.0	1.0	
3	Retry waiting time	Set	B03	1.0	1.0	1.0	
4	Electronic thermal level	Set	B12	note	note	note	Rated current of each inverter
-	Electronic thermal level (2 nd setting)	Set	B212	note	note	note	
5	Electronic thermal characteristics	Set	B13	01	01	00	
-	Electronic thermal characteristics (2 nd setting)	Set	B213	01	01	00	
6	Overload restriction operation mode	Set	B21	01	01	01	
7	Overload restriction level	Set	B22	note	note	note	Rated current * 1.25 for each inverter
8	Deceleration rate while overload restriction	Set	B23	1.0	1.0	1.0	
9	Selection of software lock	Set	B31	01	01	01	
10	Analog meter adjustment	Set	B81	80	80	80	
11	Start frequency adjustment	Set	B82	0.5	0.5	0.5	
12	Carrier frequency	Set	B83	5	5	12	
13	Data initialization or Trip history clear	Set	B84	00	00	00	
14	Initialization mode	Set	B85	01	02	00	
15	Frequency converting value	Set	B86	1.0	1.0	1.0	
16	STOP key condition	Set	B87	00	00	00	
17	Restart mode after FRS invalid	Set	B88	00	00	00	
18	Monitor contents for OPE-J	Set	B89	01	01	01	
19	Dynamic braking usage ratio	Set	B90	00	00	00	
20	Stopping mode selection	Set	B91	00	00	00	
21	Cooling fan control selection	Set	B92	00	00	00	

(5) Inverter specifications (Extended function mode : C group)

Display Order	Function name	Category	Screen display	Initial			Remarks
			Code display	EU	US	JPN	
1	Input terminal 1 assign	Set	C01	00	00	00	
2	Input terminal 2 assign	Set	C02	01	01	01	
3	Input terminal 3 assign	Set	C03	02	16	02	
4	Input terminal 4 assign	Set	C04	03	13	03	
5	Input terminal 5 assign	Set	C05	18	09	09	
6	Input terminal 6 assign	Set	C06	09	18	18	
7	Input terminal 1 condition	Set	C11	00	00	00	
8	Input terminal 2 condition	Set	C12	00	00	00	
9	Input terminal 3 condition	Set	C13	00	00	00	
10	Input terminal 4 condition	Set	C14	00	01	00	Note 1
11	Input terminal 5 condition	Set	C15	00	00	00	
12	Input terminal 6 condition	Set	C16	00	00	00	
13	Output terminal 11 assign	Set	C21	01	01	01	
14	Output terminal 12 assign	Set	C22	00	00	00	
15	FM terminal condition	set	C23	00	00	00	
16	Function of AL terminal setting	Set	C24	05	05	05	
17	Output terminal 11 condition	Set	C31	00	00	00	
18	Output terminal 12 condition	Set	C32	00	00	00	
19	AL output terminal condition	Set	C33	01	01	01	
20	Level of overload signal	Set	C41	note	note	note	Rated current of each inverter
21	Arrival frequency while acceleration	Set	C42	0.0	0.0	0.0	
22	Arrival frequency while deceleration	Set	C43	0.0	0.0	0.0	
23	Level of deviation signal under PID control	Set	C44	3.0	3.0	3.0	
24	Analog input O adjustment	Set	C81	--	--	--	
25	Analog input OI adjustment	Set	C82	--	--	--	
26	Debug mode selection	Set	C91	00	00	00	
27	Core monitor address	Set	C92	0000	0000	0000	
28	Core monitor data	Set	C93	--	--	--	
29	Core set address	Set	C94	D0001	D000	D000	
30	Core set data	Set	C95	--	--	--	

Note 1

USP function (NC) is allocated on US version and even another function such as CF1 is set, NO/NC parameter is still the same. Therefore, please make sure the NO/NC parameter to suit the application.

(6) Inverter specifications (Extended function mode : H group)

Display Order	Function name	Category	Screen display	Initial			Remarks
			Code display	EU	US	JPN	
1	Auto tuning setting	Set	H01	00	00	00	
2	Motor data selection	Set	H02	00	00	00	
-	Motor data selection(2 nd setting)	Set	H202	00	00	00	
3	Motor capacity setting	Set	H03	*3	*3	*3	
-	Motor capacity setting(2 nd setting)	Set	H203	*3	*3	*3	
	Motor poles setting		H04	4	4	4	
	Motor poles setting(2 nd setting)		H204	4	4	4	
4	Speed response setting	Set	H05	20	20	20	
-	Speed response setting(2 nd setting)	Set	H205	20	20	20	
5	Motor stabilization constant setting	Set	H06	100	100	100	
-	Motor stabilization constant setting(2 nd setting)	Set	H206	100	100	100	
6	Motor constant R1 setting	Set	H20	*2	*2	*2	
-	Motor constant R1 setting(2 nd setting)	set	H220	*2	*2	*2	
7	Motor constant R2 setting	Set	H21	*2	*2	*2	
-	Motor constant R2 setting(2 nd setting)	Set	H221	*2	*2	*2	
8	Motor constant L setting	Set	H22	*2	*2	*2	
-	Motor constant L setting(2 nd setting)		H220	*2	*2	*2	
11	Motor constant I _o setting		H23	*2	*2	*2	
-	Motor constant I _o setting(2 nd setting)		H223	*2	*2	*2	
12	Motor constant J setting		H24	*2	*2	*2	
-	Motor constant J setting(2 nd setting)	Set	H224	*2	*2	*2	
13	Motor constant R1(auto tuning data)	*1	H30	*2	*2	*2	
-	Motor constant R1(auto tuning data, 2 nd setting)	*1	H230	*2	*2	*2	
14	Motor constant R2(auto tuning data)	*1	H31	*2	*2	*2	
-	Motor constant R2(auto tuning data, 2 nd setting)	*1	H231	*2	*2	*2	
15	Motor constant L(auto tuning data)	*1	H32	*2	*2	*2	
-	Motor constant L(auto tuning data, 2 nd setting)	*1	H232	*2	*2	*2	
16	Motor constant I _o (auto tuning data)	*1	H33	*2	*2	*2	
-	Motor constant I _o (auto tuning data, 2 nd setting)	*1	H233	*2	*2	*2	
17	Motor constant J(auto tuning data)	*1	H34	*2	*2	*2	
-	Motor constant J(auto tuning data, 2 nd setting)	*1	H234	*2	*2	*2	

*1; don't change the data

*2 ; factory set

*3 ; specified by the capacity of each inverter

[2] Motor specifications.

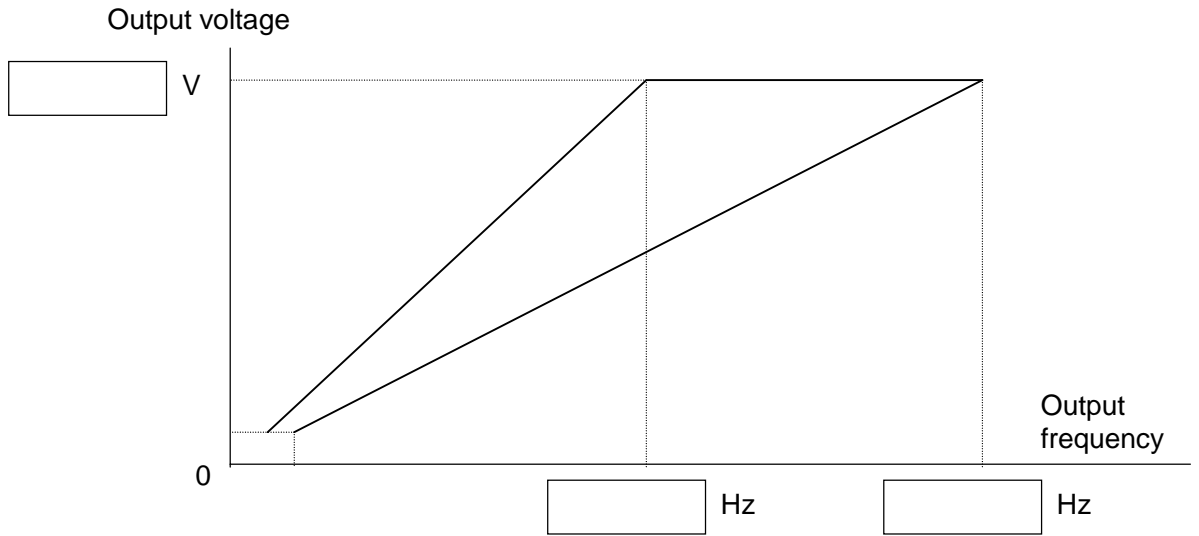

Motor MFG number

Motor output kW Rated current Amps

Motor poles p Rated voltage V

Motor rated rpm rpm Rated frequency Hz

Starting current Amps

[3] Load conditions

Equipment name

Torque characteristics Acceleration time sec

Required torque Nm Deceleration time sec

Load inertia (J) kgm² Variable speed range

Hz to Hz

2. Measurement of the Internal Voltage Supply

There are PV5L, PV24L and NV12L internal DC voltage supplies. These supplies are isolated from the main high voltage portion. And it is not possible to measure DC voltages at the non isolated portion. Please make measurements for above mentioned voltages for the isolated portion.

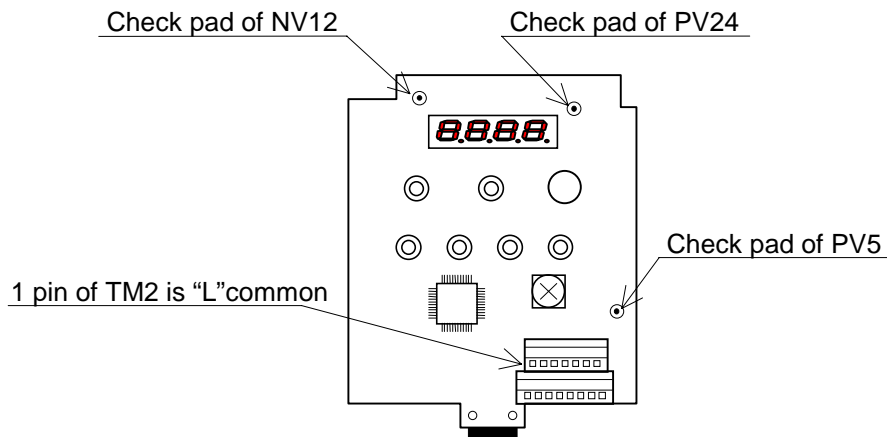

PV5L supply voltage

Supplies 5V for I/O board.
Nominal voltage : min. 4.90Vdc to max. 5.20Vdc
Check PV5(address 1C) <- L

PV24L supply voltage

Supplies 24V to interface voltage supply, which is supplied to input terminals.
Nominal voltage : min. 21.60Vdc to max. 26.40Vdc
Check PV24(address 1A) <- L

NV12L supply voltage

Supplies -12Vdc to remote operator (DOP/DRW's yellow back light).
Nominal voltage : max. -10.80Vdc to min. -17.5Vdc
Check NV12(address 3A) <- L

"H" terminal voltage

Supplies 10V to "H" terminal
Nominal voltage : min 9.5Vdc to max 11.5Vdc
Check "H" <-> "L" with VR (1kohm)

"Potentiometer function on the front case

Set "A01" : "00"
Monitor "F01" display 0 <-> 50(60) with clockwise and anti clockwise.

Cooling FAN voltage (PV24N)

Supplies 24V to cooling FAN .
Nominal voltage min 19.9Vdc to max 27.2Vdc.
Check Red wire <- Black wire with the FAN.
Check the FAN working, direction(from down to up).

3. Trouble Shoot

3-1. Error Messages - Possible Cause and Remedy:

(1) Over current 1 (E 01, E 02, E 03, E 04)

Phenomena:	Over current (CT or Rsh;gate driver IC) for each condition. E 01 : Over current during constant speed operation. E 02 : Over current during deceleration. E 03 : Over current during acceleration. E 04 : Over current at other condition than above mentioned. (such as injection brake)
Cause:	Load changed rapidly.
Remedy:	Eliminate rapid changed in load.
Cause:	Sort circuit or earth contact (ground fault) in the motor or the motor cable.
Remedy:	Check with Megger. If the motor cable is disconnected from the inverter, the over current should not be detected anymore.
Cause:	A single-phase power failure (fuse, wire, ...) can cause a shutdown in certain under load situations..
Remedy:	Check all these mains phases and the mains fuses, preferably by comparison of the three (two in case of single phase inverter) mains currents in a steady operating state.
Cause:	The motor is switched with a motor contactor during frequency inverter operation.
Remedy:	Switching over the motor is inhibited.
Cause:	Defect in the power component.
Remedy:	Check the IGBT portion of ISPM.
Cause:	Rapid acceleration or deceleration.
Remedy:	Set suitable acceleration or deceleration time.
Cause:	Starting frequency is too high.
Remedy:	Set starting frequency as low as possible.
Way to Reset:	A

SJ100 has two kinds of detection; CT and Rsh. To resolve the detection at site, check the following procedure.

1. Connect DOP/DRW.
2. Set F38 INIT DEBG ON. (to access debug mode)
3. Set F22 IPS POWR ALM mode, don't set retry mode.
4. Test run and wait Over Current trip.
5. Set Core address "FBE4" if it's 4kW or less.
5. Set Core address "FBE2" if it's 5.5kW or above.

Specimen ;

“CO FBE4 01 0000” ; under normal; 0Hz

“CO FBE4 15 0203” ; under over.C trip

“CO FBE4 15 C203” ; under OC.Drive trip.

“CO FBE4 15 4103” ; under OC.Accel trip

“FBE4” or “FBE2” is 1 byte data, the data is hex data. Example “4103”; “03” has no meaning.

Resolve “41”h bit by bit,

“41”h -> “0100 0001”b

if you found “xxxx xxx1” ; this means Over current detection from CT (CTU or CTW)

if you found “xxxx xx1x” ; this means Over current detection from Rsh

Standard operator is not available on this trouble shooting.

(2) Overload (E 05)

Phenomena: Overload (detected by CT) of the inverter.
This error can be reset 10 seconds after the E05 came out.

Cause: Motor load is heavy.
Remedy: Reduce the load and/or increase thermal level and/or use bigger capacity of frequency inverter.

Cause: V-Boost value is high.
Remedy: Reduce V-Boost value or increase thermal level and/or use bigger capacity of frequency inverter.

Cause: Set wrong value for electronic thermal level [b12] and/or electronic thermal characteristic [b13].
Remedy: Set suitable value.

Cause: Set wrong value for the reactive current of the motor.
Remedy: Set suitable value. Reactive current value which should be input by function mode is a value measured at 50Hz (60Hz) without load.

Way to Reset: A

(3) Braking Resistor Overload (over voltage) (E 06)

Phenomena: Over Voltage detection after BRD%ED was run out.

Cause: BRD selection is not suitable.
Remedy: Check BRD %ED, BRD resistor ohm, BRD resistor Wattage, BRD resistor wire, machine inertial, operation cycle.

Way to Reset: A

(4) Over voltage (E 07)

- Phenomena: Over voltage at DC bus line of the frequency inverter.
- Cause: Mains voltage too high, mains voltage fluctuation or rapid mains voltage return (choke energy leads to voltage increase).
- Remedy: Make sure that mains voltage is within tolerance limits.
- Cause: In case SJ100 is used in combination with a regenerative braking unit(ISPM)/resistor but the regenerative braking unit(ISPM)/resistor does not function.
- Remedy: Replace regenerative braking unit(ISPM)/resistor.
- Cause: In case SJU100 is used in combination with a raking resistor but the braking resistor cannot absorb the regenerative energy.
- Remedy: Re-calculate and use suitable braking resistor.
- Cause: Deceleration time is too short.
- Remedy: Make deceleration time longer, use braking unit (resistor), use bigger capacity of frequency inverter.
- Way to Reset: A

(5) Under voltage (E 09)

- Phenomena: Under voltage at DC bus line of the frequency inverter.
- Cause: The mains voltage is not available or not within the tolerance limits.
- Remedy: Check all 3 (or 2) mains power supply voltage that it is within its specification.
- Cause: Thyristor for smooth charging is defect and DC bus voltage drops while operation due to current flows through smooth charging resistor.
- Remedy: Change ISPM.
- Cause: Period of instantaneous power failure is longer than the set value [b02], or DC bus voltage go down to its detecting level while instantaneous power failure.
- Remedy: Get rid of the instantaneous power failure, evaluate the power supply system, set bigger value for [b02].
- Cause: One of the AC voltage is missing (applied only for 3 phase INV)
- Remedy: Check AC line voltage , check the fuses.
- Way to Reset: A

(6) EEPROM error (E 08)

- Phenomena: Abnormal situation occurs at the memory portion of the frequency inverter due to incoming noise etc..
- Cause: Influenced by Electrical Magnetic Interference.
- Remedy: Keep such noise source away from the frequency inverter.
- Cause: Ambient temperature is too high.
- Remedy: Take countermeasure against high ambient temperature.

Cause: Re-power up the frequency inverter short time after power off. It is necessary to keep several seconds after power off to memorize the current data at EEPROM. If this time is too short, this storage performance cannot be done and leads to EEPROM error.

Remedy: Keep certain time between power off and re-power up.

Cause: You didn't wait 6 seconds or more at FACTORY SETTING.

Remedy: Please try FACTORY SETTING again.

Cause: RS terminal was keeping "ON" at power off. (If RS is on, INV can not write the correct data to EPROM at power off, next power on E08 will come out.)

Remedy: Please don't use "RS" terminal "ON" at power off.

Cause: EEPROM is defect.

Remedy: Change unit.

After you reset the INV, please make sure the parameters especially maximum freq. / Acc /Dec time / Low limit freq. to prevent any damage.

Way to Reset: A or Power off

(7) CT error (E 10)

Phenomena: When abnormality noise is near the INV or an abnormality (offset level is out of spec.) occurs on built in CT.

Cause: Influenced by Electrical Magnetic Interference. (such as near contactor on/off)

Remedy: To Resolve if it's influence, use another power line and don't connect motor wires, control wires. If no error comes out, resolve noise causes.

Cause: CT offset level failure

Remedy: To Resolve if it's failure, use another power line and power on and check if E10 comes out at power on. If E10 came out , use (replace) another INV(ISPM).

Way to Reset: A or Power off

(8) CPU error (E 11, E 22)

Phenomena: Abnormal situation or malfunction of micro processor inside frequency inverter.

E 11 : CPU error from MCU inside core.

E 22 : CPU error from MCU on I/O board.

E22 is produced by MCU on I/O board and the causes is communication error between ISPM & MCU on I/O board.

Cause: Cable (between ISPM and I/O board)was cut. (E22)

Remedy: Replace the cable.

Cause: Dusts on the pins of CN2 on I/O board. (E22)

Remedy: Remove the dusts.

Cause: Influenced by Electrical Magnetic Interference.

Remedy: Keep such noise source away from the frequency inverter.

Cause: Ambient temperature is too high.

Remedy: Take countermeasure against high ambient temperature.

Cause: Component itself is defect.
Remedy: **Replace ISPM (in case of E 11) or I/O board board (in case of E 12).**

(9) External Trip (E 12)

Phenomena: Trip due to have inputted an external signal to “EXT” input terminal of the frequency inverter.
Cause: Faulty external device or equipment gives frequency inverter a trip requirement when external trip function (EXT) is selected.
Remedy: Evaluate external device or equipment which is connected to frequency inverter.
Way to Reset: A

(10) USP error (E 13)

Phenomena: Unexpected Start Protection. This error can occur when “USP” function is selected.
Cause: Frequency inverter trips when it is powered up with RUN command is given.
Remedy: Disable RUN command when power up the frequency inverter. Or disable USP function if possible to the system.
Way to Reset: A or set RUN command off (stop)

(11) Ground fault error (E 14)

Phenomena: Earth contact in the motor or the motor cable or in the IGBT. Frequency inverter detects this earth contact only at power up.

To resolve the causes , please power off and disconnect the motor wire at INV (UVW)terminal.

Cause: Earth contact in the motor or the motor cable.
Remedy: Check the impedance between output portion(wire and motor) and earth.

Cause: Detection circuit/IGBT of the inverter is defect. If the motor and the motor cable is disconnected from the frequency inverter, the ground fault should not be detected anymore.
Remedy: Please disconnect the motor and the motor cable.
If E14 comes out at power on, please replace the unit.

Way to Reset: Don't reset.

(12) Over voltage at source (E 15)

Phenomena: High voltage at power source line. Frequency inverter cannot protect source over voltage. If it is too high, frequency inverter will be damaged.

Cause: Source voltage is too high.
Remedy: Check the source voltage continuously.
Insert AC reactor at source lines.

Way to Reset: A

(13) Over temperature (E 21)

Phenomena: Temperature sensor which located close to IGBT inside ISPM shows a too high temperature.

Cause: Ventilator blocked. (for models which has ventilator.)
Remedy: Check ventilator

Cause: The frequency inverter does not get enough cooling air.
Remedy: Check cabinet ventilation, air filters, and ventilation openings in the cabinet.

Way to Reset: A

(14) PTC error (E 35)

Phenomena: Resistance of motor thermistor is high. This error can occur when you select "PTC" function.

Cause: Too much load of the motor.
Remedy: Reduce the load, use bigger motor.

Cause: Motor thermistor is not connected while PTC function is selected.
Remedy: Disable PTC function when it is not used.

Cause: Characteristics of the motor thermistor is not suitable. Frequency inverter gives PTC error when the resistance value becomes more than 3k ohm +-10%.
Remedy: Use motor which has suitable thermistor for the inverter.
Or change thermistor characteristics of the thermistor by debug mode.

Way to Reset: A

Explanation of the way to reset.

A : Make close the terminals between RS and P24 (CM1 only for Japanese version) on the I/O board, or press "STOP/RESET" key of the operator.

3-2. Analysis of Various Operating Problems That Do Not Trigger an Trip message.

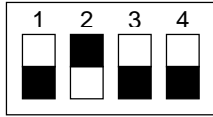
Problem	Possible cause	Remedy
The motor does not start	Mode of frequency command [A01] and/or Run command [A02] is not proper	Check each mode again
	Incorrect power supply condition	Check that the power supply is within its specification
	Inverter is in trip mode	Get rid of the trip cause
	0 Hz of Multi-stage speed is given	
	FRS and/or RS is remaining	Make FRS and RS invalid
	0 Hz command is given	
	Each phase to phase voltage does not balance. (out of +3%)	Replace the unit
	Load is too heavy	Decrease the load or use bigger capacity of inverter and motor
If you use DOP or DRW, DIP switch selection of the operator is incorrect.		Set as follows 
		Same as J300, J100, L100
	Inverter Failure	Replace the unit
Rotation direction is opposite	Wiring of the motor cable is incorrect (U, V, W)	Check the wiring of the motor cable
	Setting of [F04] is incorrect	Check the setting
Motor does not increase speed	Motor load is too heavy (Overload limitation)	Remove or decrease the motor load
	External frequency set (VR) is out of order	replace VR
	Frequency limiter [A61] is set	Eliminate frequency limiter
	Acceleration time is too short	Set longer acceleration time
The inverter cannot be programmed	Software lock is selected [b31]	Make software lock invalid
	While INV running	Stop the INV
	RS or FRS command is given	Make them invalid
	Multi stage speed command is given	Make inverter in stop mode
	Loose connection of DOP/DRW	Connect DOP/DRW properly
Unstable rotation of the motor	Inverter is in trip mode	Reset the inverter
	Motor load is changing heavily	Reduce the motor load changing or use bigger capacity of inverter and motor
	Source voltage is changing	Reduce the changing
Data is not changed	Mechanical resonance	Change output frequency
	Forgot to press [STR] key	Press [STR] key after changing data
Cannot change data by Copy Unit	Turn main power off within 6 seconds after pressing [STR] key	Make sure to wait at least 6 seconds after [STR] key is pressed
	Turn power off within 6 seconds after started copying	Make sure to wait at least 6 seconds

3-3. How to Initialize the Data (FACTORY SETTING)



1. Select the mode of initialization data to which you want to initialize by [b85].



- Japanese version data -----> Set "00" and store
- EU version data -----> Set "01" and store
- US version data -----> Set "02" and store

2. Set [b84] to "01" to initialize and store.

3. Keep pressing    keys at the same time.

(If front case is not closed by the screw, difficult to press 3keys.)

4. Additionally press  key and release  key approximately after one second.

5. Keep pressing    keys until "d 00" will blink. (Approximately 2 seconds.)

6. Release all the keys after starts blinking.

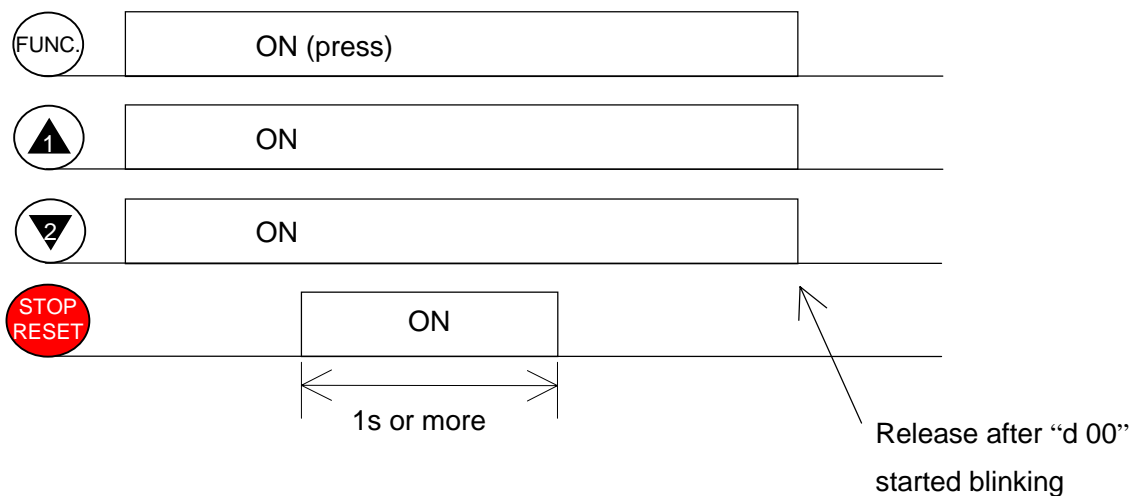
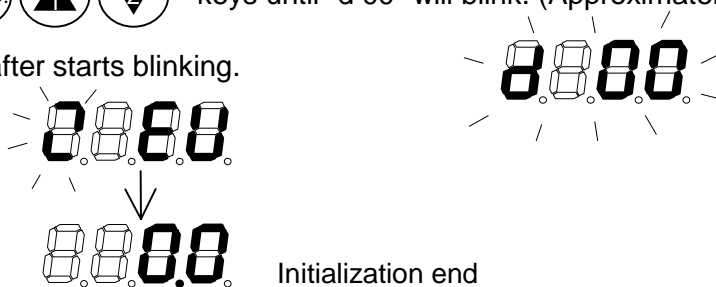







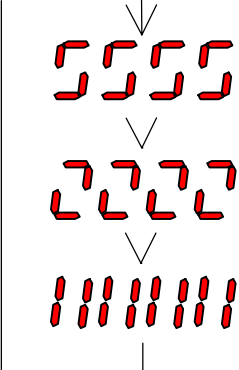

[c95] ; INV kW code

- 01;0.2kW , 02;0.4kW , 03;0.75kW (0.5 kW) , 04;1.5kW , 05;2.2kW ,
- 06;3.7kW(4.0kW) , 07;5.5kW, 08;7.5kW

3-4. Error Message comparison

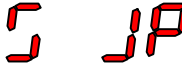
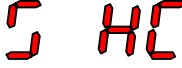
Digital Panel	DOP / DRW	Contents
E 01	OC. Drive	Over current while constant speed driving (CT or gate driver IC)
E 02	OC. Decel	Over current while deceleration (CT or gate driver IC)
E 03	OC. Accel	Over current while acceleration (CT or gate driver IC)
E 04	Over. C	Over current at other condition than above(such as 0Hz,injection brake) (CT or gate driver IC)
E 05	Over. L	Over load (Possible to reset after 10 seconds has passed, detected by CT)
E 06	OL. BRD	Over voltage after the BRD%ED was run out. (DC bus)
E 07	Over. V	Over voltage (DC bus)
E 08	EEPROM	EEPROM error (Check the parameters again if this error occurred)
E 09	Under. V	Under voltage (DC bus)
E 10	CT	CT offset error such as external noise or CT itself
E 11	CPU 1	CPU error
E 22	CPU 2	
E 12	External	External error
E 13	USP	USP error
E 14	GND Flt	Ground fault at power-on detected by CT
E 15	OV. SRC	Over voltage at source (DC bus) (continuously 100sec while stop)
E 21	OH FIN	Over temperature (in the ISPM)
E 35	PTC	PTC error (only terminal 5)

3-5. Other Displays

Digital Panel	Contents
	<ul style="list-style-type: none"> - Reset terminal is ON - During initialization (such as at power-on)
	<ul style="list-style-type: none"> - Voltage is within UV level - Power OFF
	<ul style="list-style-type: none"> - During retry mode
	<ul style="list-style-type: none"> - During initialization as EU settings
	<ul style="list-style-type: none"> - During initialization as US settings
	<ul style="list-style-type: none"> - During initialization as Japanese settings
	<ul style="list-style-type: none"> - Erasing trip histories
	<ul style="list-style-type: none"> - Copying with DRW,DRW-2
	<ul style="list-style-type: none"> - When there is no data (i.g. feedback data of PID, etc.)
	<ul style="list-style-type: none"> Auto tuning was done.
	<ul style="list-style-type: none"> Auto tuning was failed.

3-6. Auto tuning under high incoming voltage

If Auto tuning is not successful , try following procedure.

1. Set C91 "01" and press STR key. (to access debug mode)
2. Set H01 "01" and press STR key. (to do auto tuning)
3. If the SJ100 is 4kW or less, set C94 "fb82" and press STR key.
3. If the SJ100 is 5.5kW or above, set C94 "fb80" and press STR key.
4. Set C95 "0000" and press STR key.
5. Run command ON. (Run key or FW terminal) to get started Auto Tuning.

4. Ambient Condition of the Frequency Inverter

4-1. Required Derating in case of 50deg, 55deg of Ambient Temperature

Inverter ratings can be influenced by many factors. You can find in this section, the relation between ambient temperature and output current (%) and carrier frequency.

- Standard ratings in 40 degree C
- Top cover removed condition in 50 degree C max.
- . - Top cover removed condition in 55 degree C max.

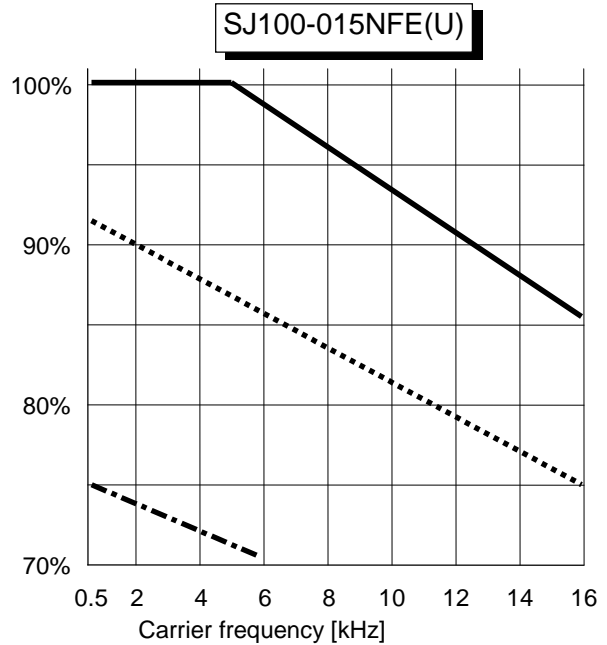
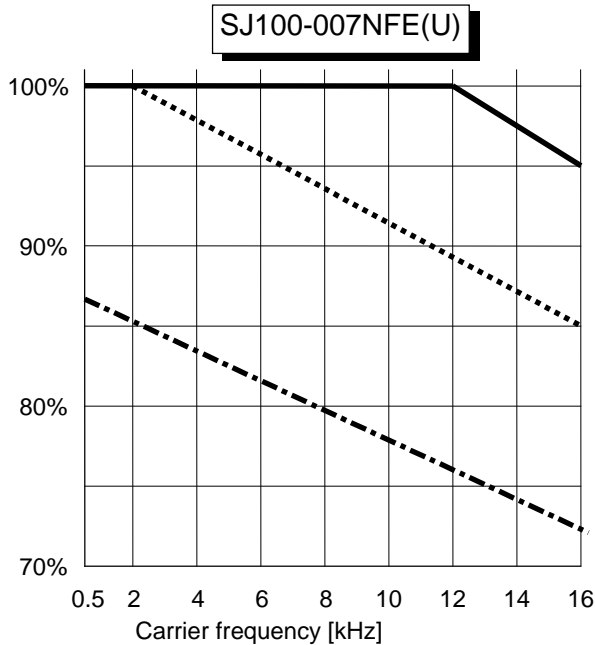
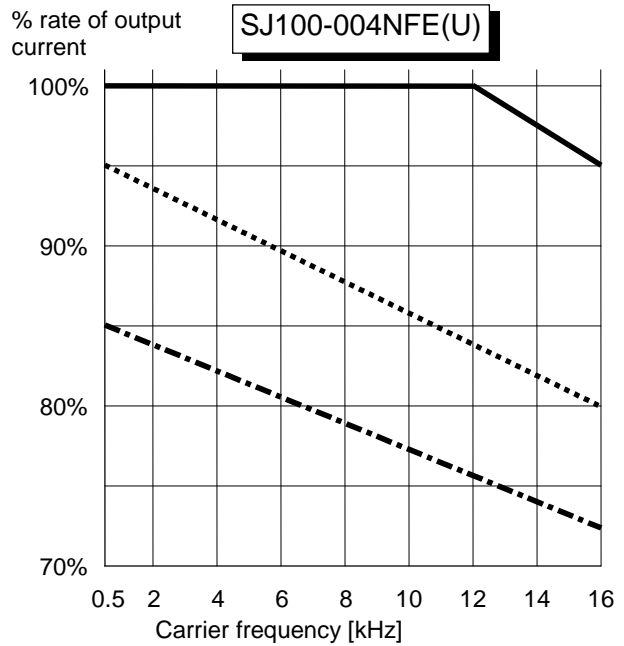
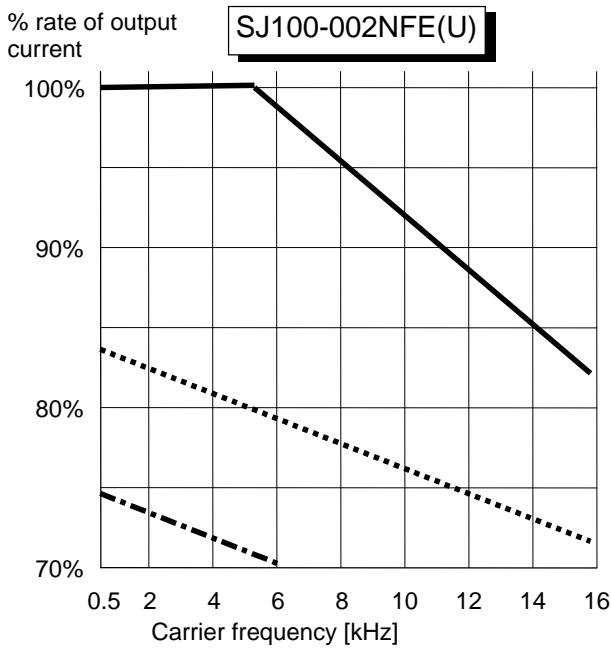

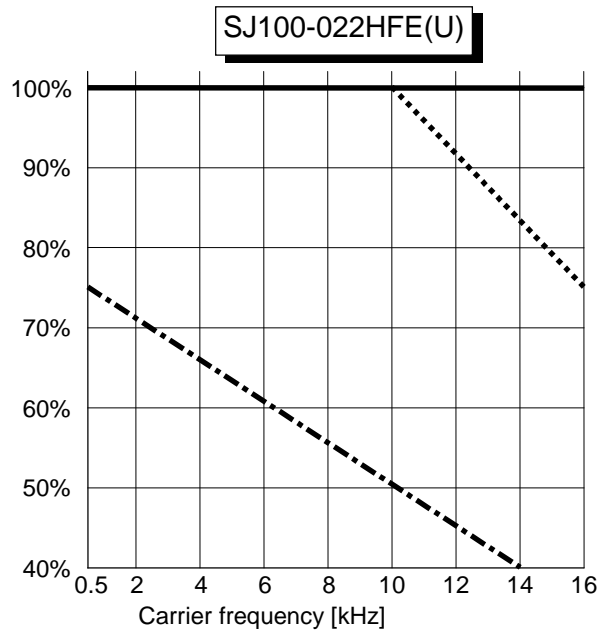
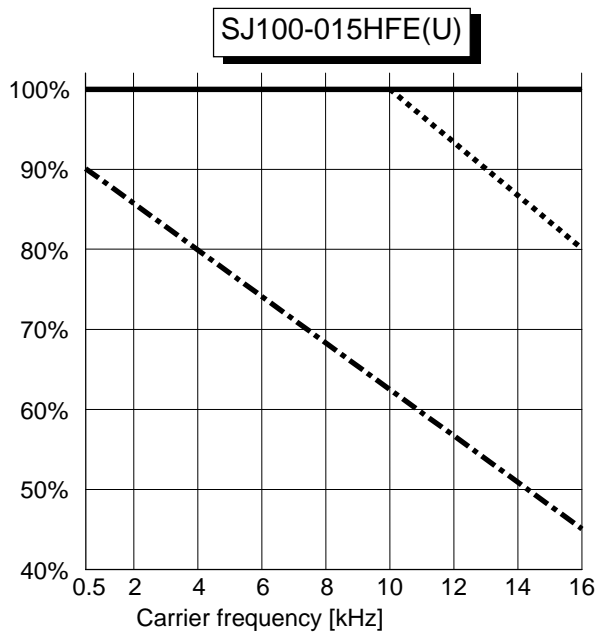
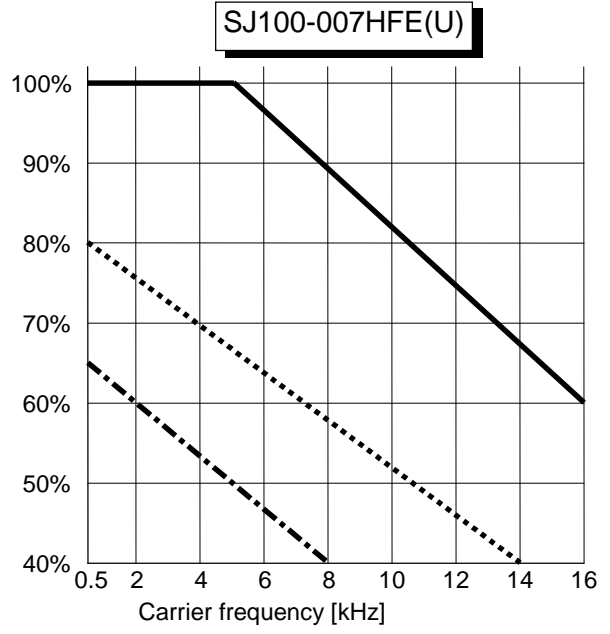
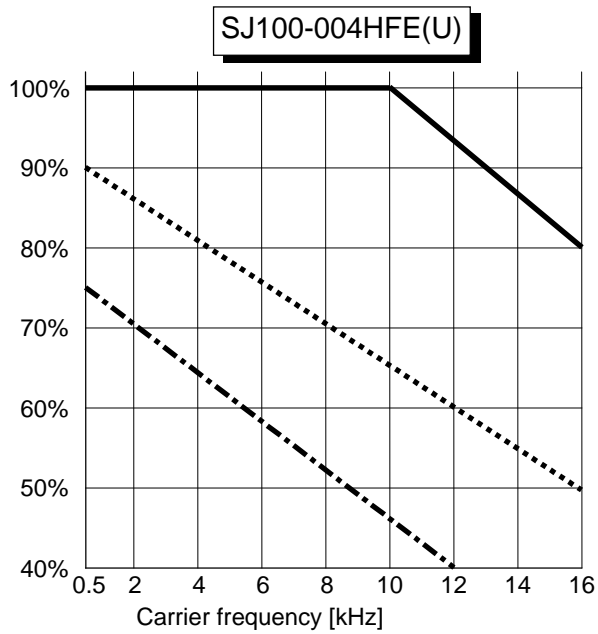
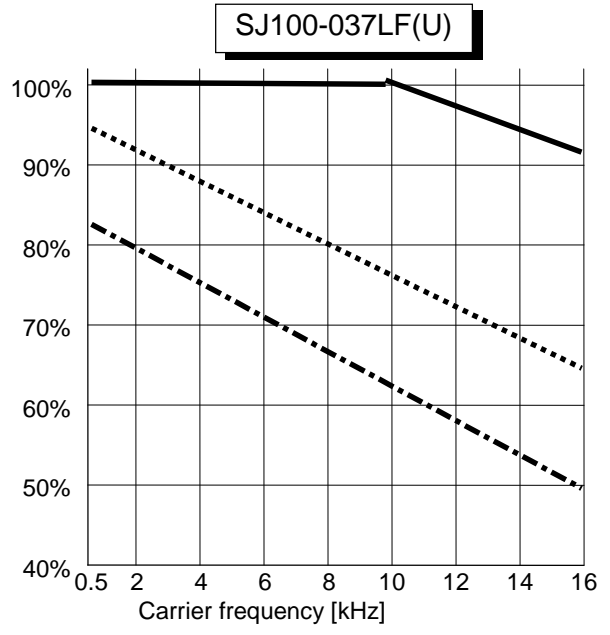
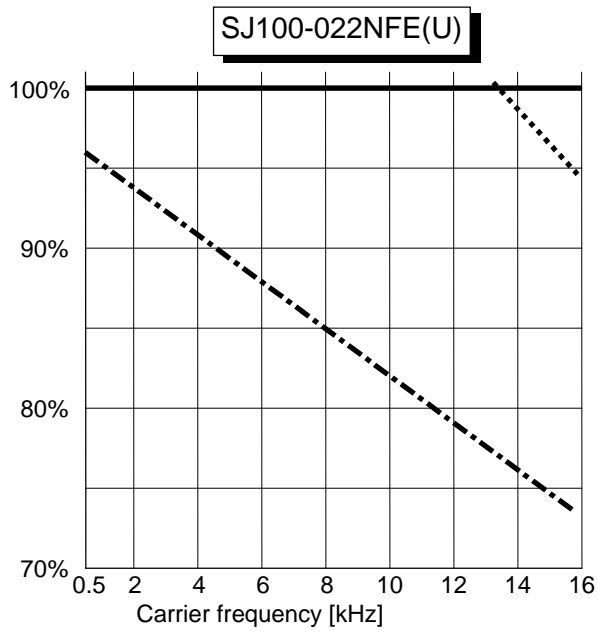

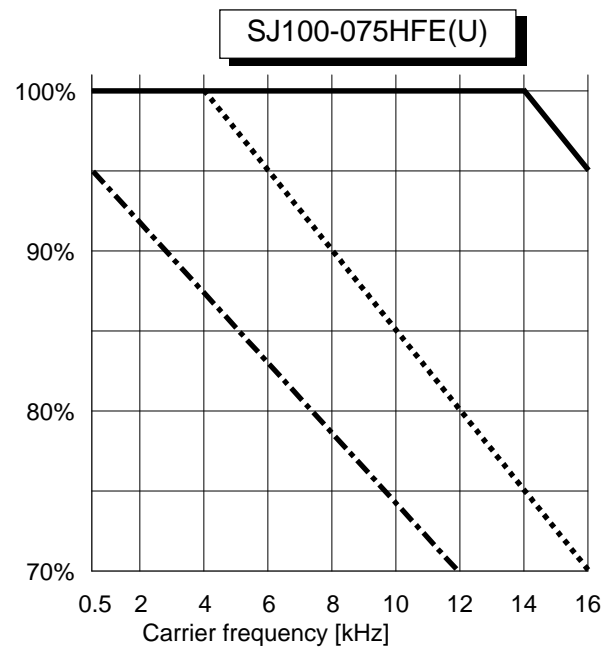
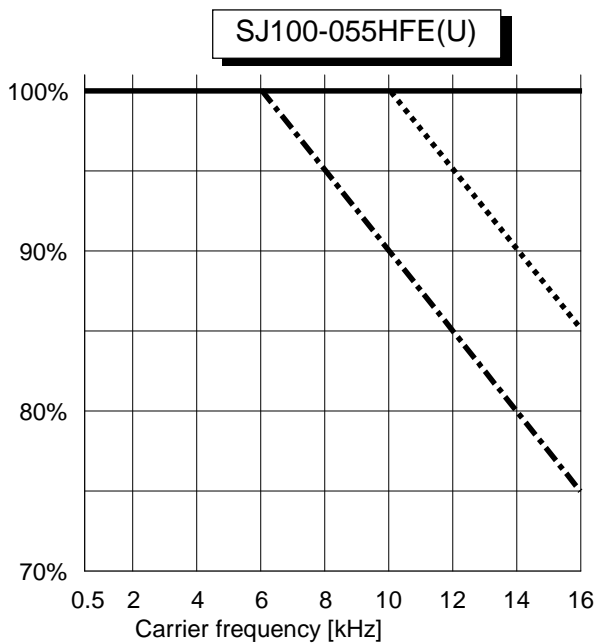
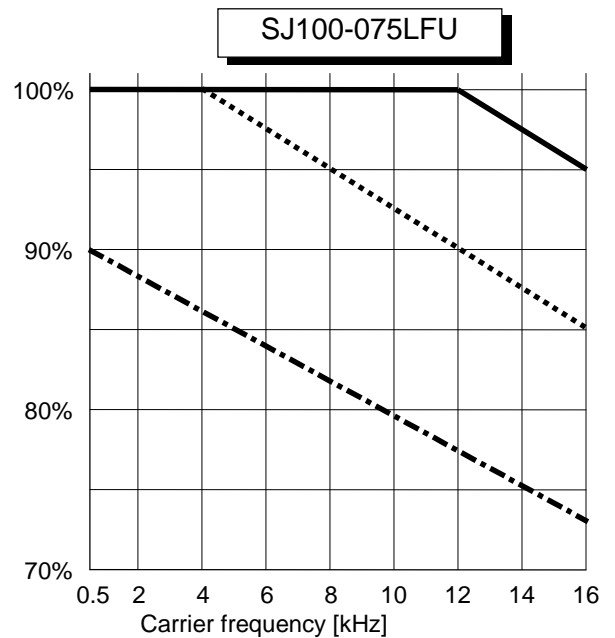
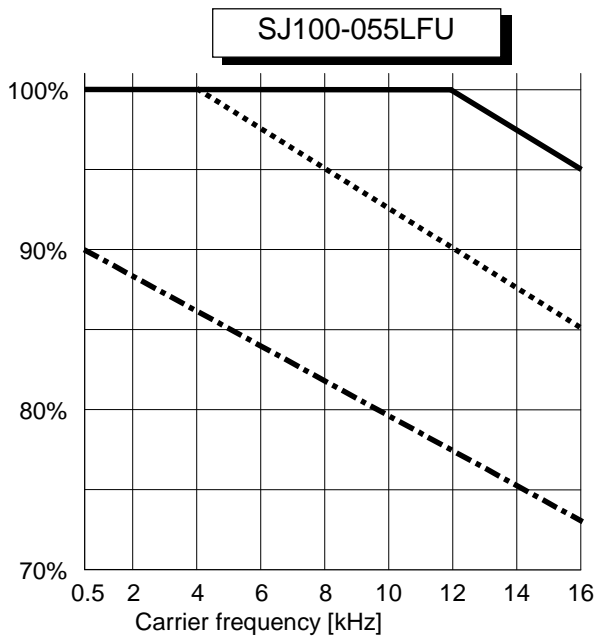
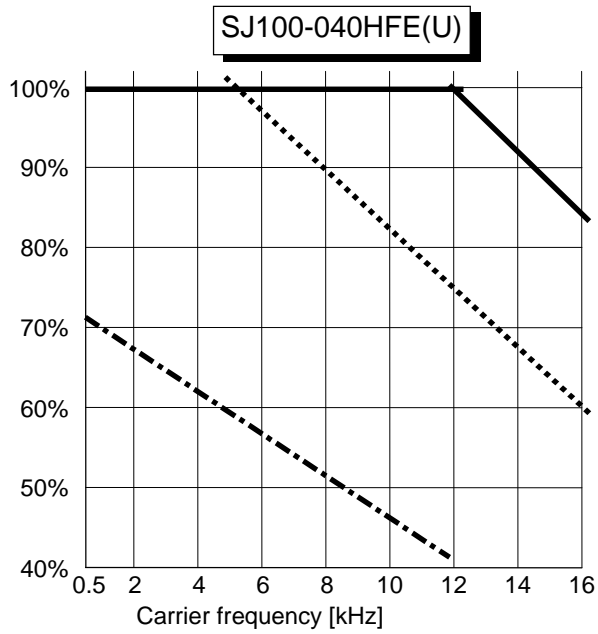

4-2. Required derating toward altitude

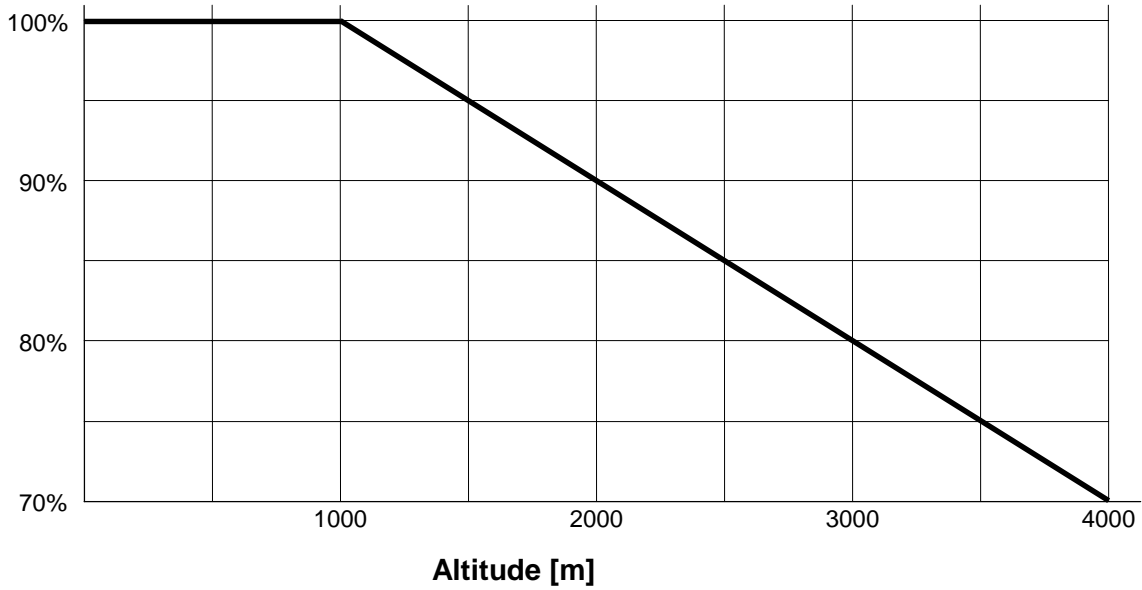

Example of calculation

SJ100-007NFE (4 Amps) is installed at 2000m of altitude and 16kHz of carrier frequency. Required derating of output frequency of this case will be as follows.

$$4 \text{ [Amps]} * 90\% * 95\% = 3.4 \text{ [Amps]}$$

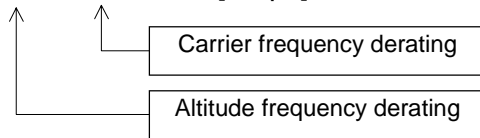

<Note 1> When the top cover is removed for the high ambient temperature, inverter should be installed in an enclosure of IP 4* (see EN60529) to comply with LVD directive.

<Note 2> If class B of EMC directive is required, carrier frequency must be set to 5kHz.

5. Level of Each Detection

5-1. DC Bus Voltage Detection Characteristics

Frequency inverter has several detection characteristics for DC bus voltage as followings.

[1] 200V class

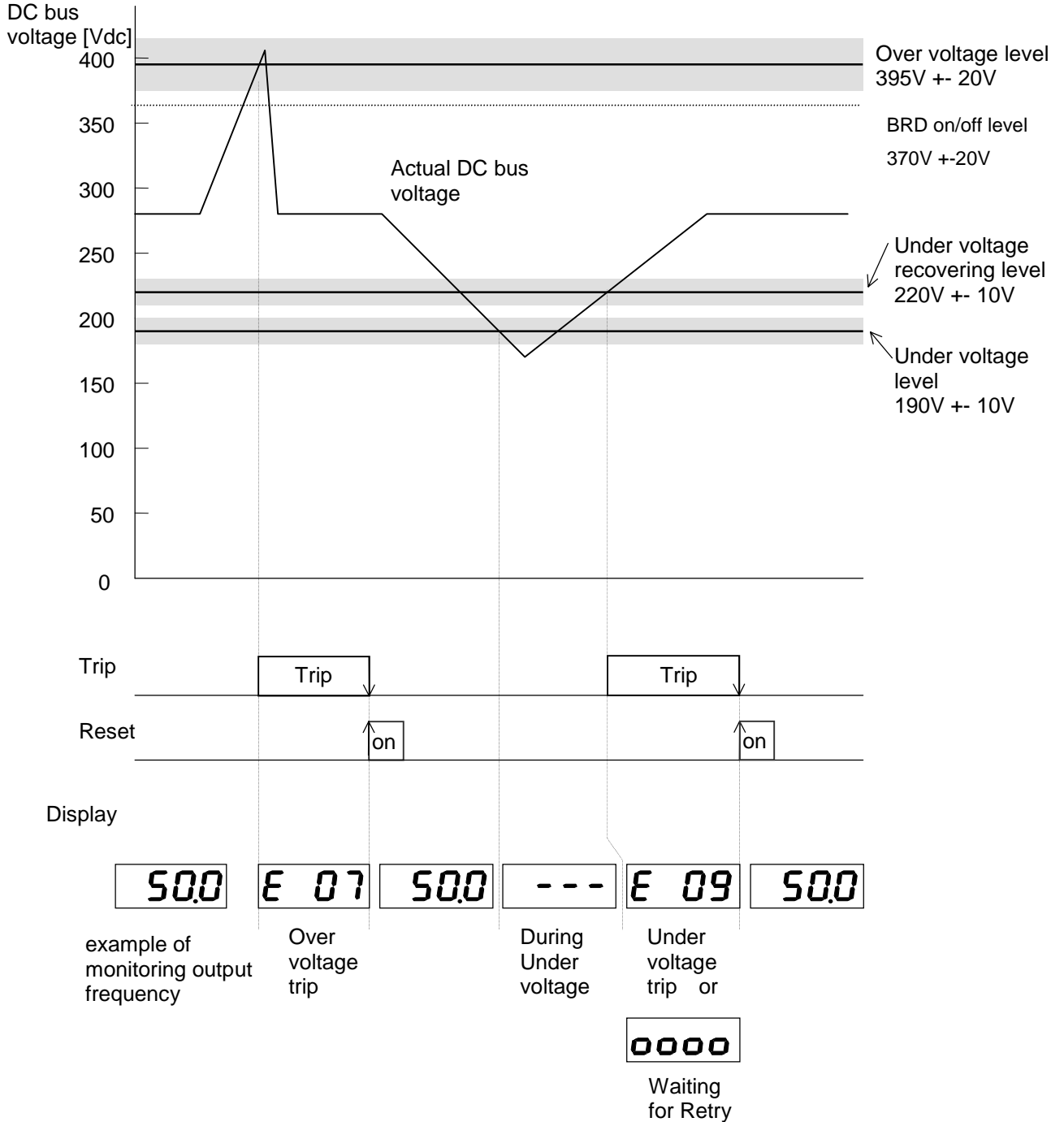

OV.SRC level ; 375V ± 20V (continuously 100sec while stop)
 BRD circuit has no hysteresis

[2] 400V class

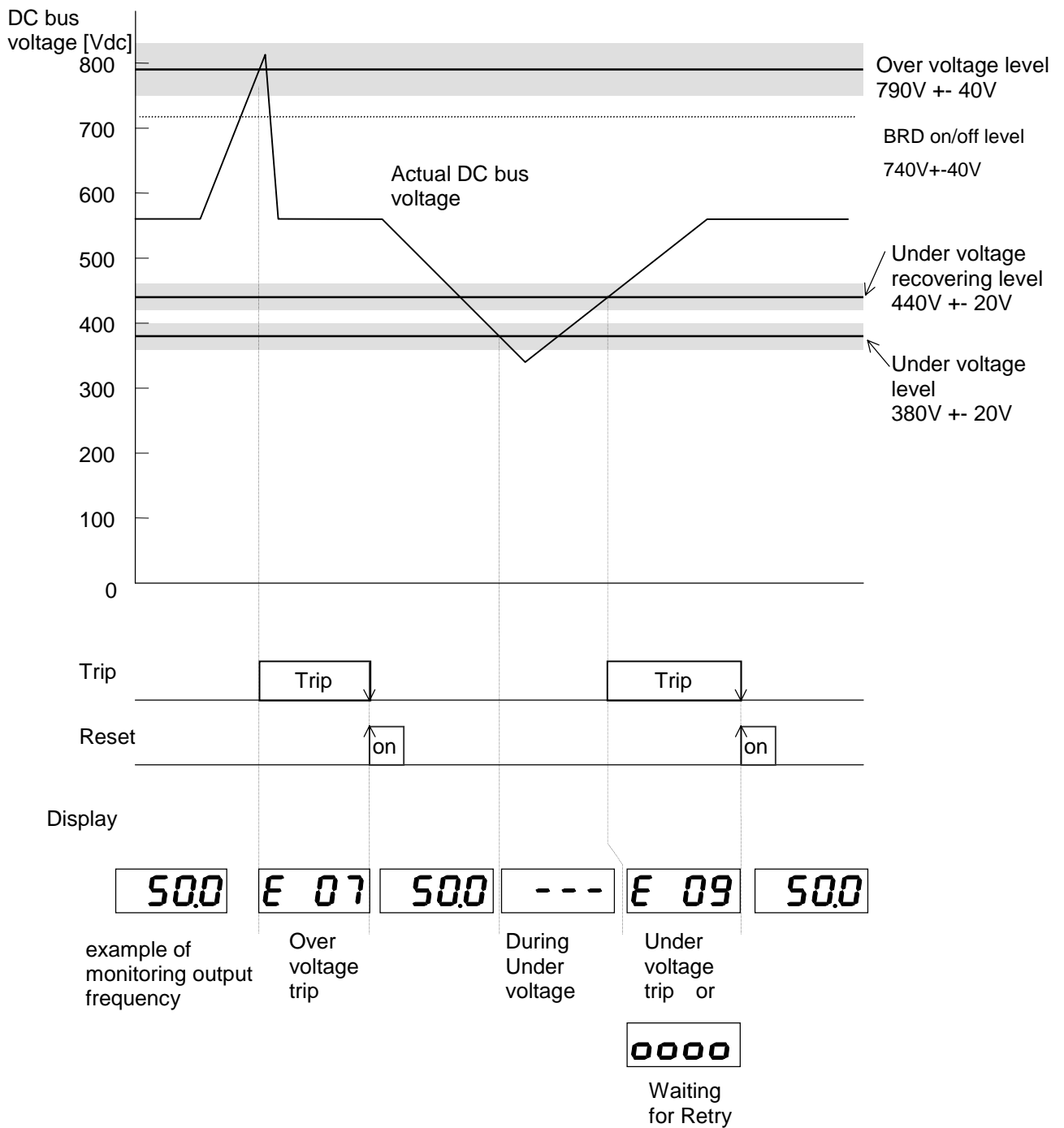

OV.SRC level ; 750V +- 40V (continuously 100sec while stop)

5-2. Output Current Detection Characteristics

Frequency inverter has several detection characteristics for output current to protect IGBT from break down, or to protect motor from over heat.

[1] Over current

Frequency inverter shuts off the output instantaneously when output current exceeds to 220%(190) of its rated current. (OC level is no link with Electronic thermal level)

e.g. Over current protection level of SJ100-015NFE (7.1 Arms of rated current) is
 $7.1 \text{ [Arms]} * 200\% = 14.2 \text{ [Arms]} = 20.1 \text{ [A peak]}$

[2] Over load (Electronic thermal protection)

Frequency inverter shuts off the output when integration value of output current and time exceeds specific value.

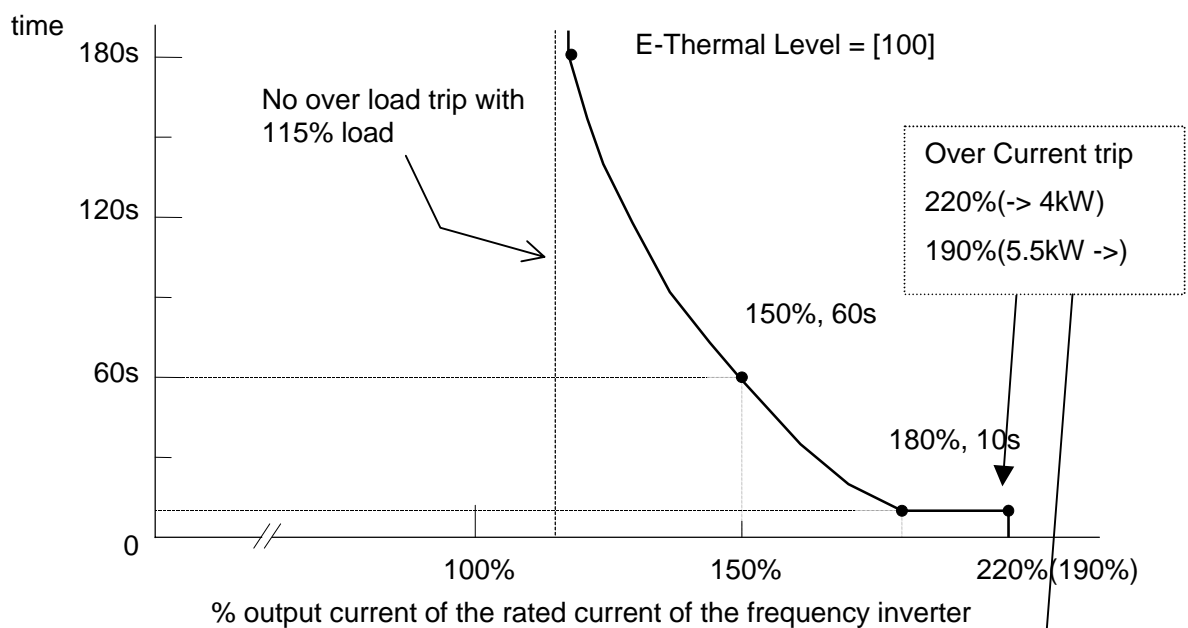

This Electronic thermal level can be changed from 50% to 120%. (Initial setting is 100%.)

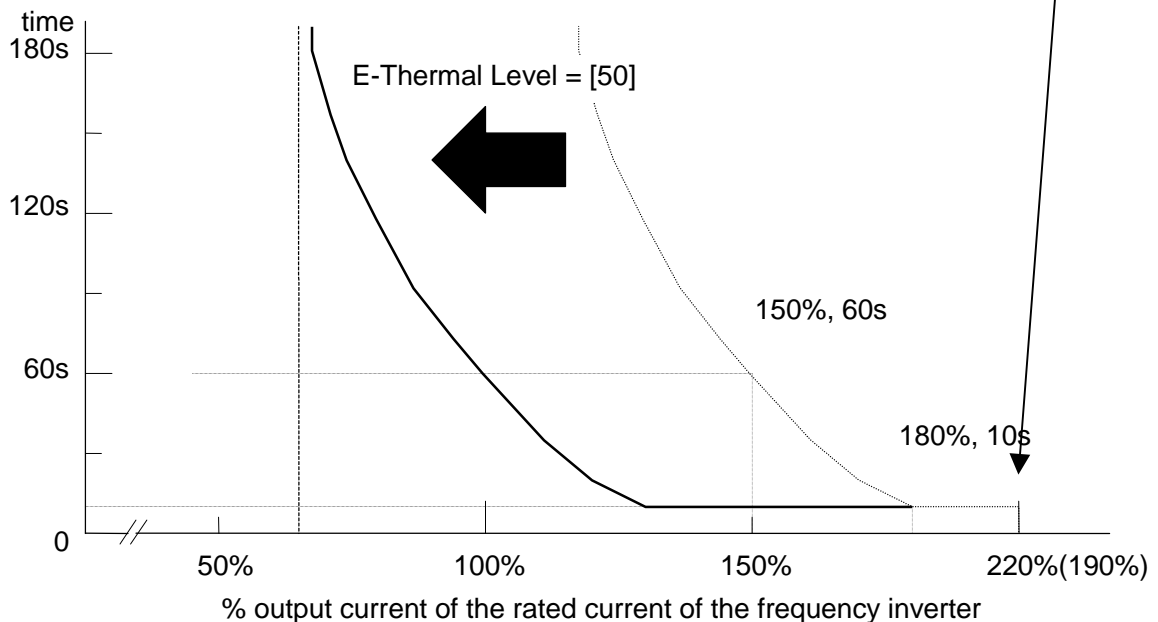

5-3. Motor Temperature Detection (PTC)

Frequency inverter has a motor temperature sensor input (PTC input : PTC resistor).

When the resistance value is more than 3k ohm +-10%, the frequency inverter trips with "E35".

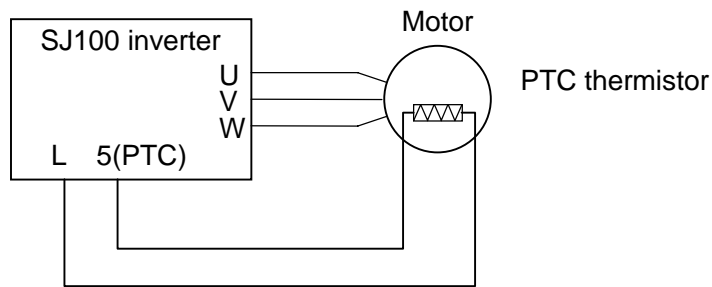

Except Japanese version

5-4. Over Temperature Detection of the Frequency Inverter

Frequency inverter has a temperature detection against power devices of the main circuit. Frequency inverter shuts down the output when temperature around IGBT comes up to 120 degree C.

6. Measurement & Replacement of Subassemblies

6-1. Insulation Measurement

For SJ100 inverter, **do not perform insulation measurements** , otherwise MOV will be damaged.
(MOV; between R(L1)-G, S(L2)-G, T(L3)-G)

6.2. Power Components Measurements.

When checking the power components, the following procedure is recommended:

- Clear voltage
- Wait for capacitors discharge
- Check capacitors for neutrality
- Disconnect mains and motor wires
- Test the diodes and IGBTs using a universal tester with a diode function.

Visual check is important for the ISPM, check the appearance such as smoke trace.

Note: In this test, the absolute values are not so important, since they depend strongly on the test device used. The uniformity of the measured value is more important.

[1] DC BUS Measurement

Check “+” <- “ - ” voltage Zero.

Resistance Measurement		Allowable Value
From	To	
+	-	50kohm or more

P1, PD are located on the CB board / snubber board.

Check “+1” and “+” terminal are shorten by (copper) bar.

[2] Soft charge Resistor (RS) , Thyristor (THY) Measurement

Resistance Measurement		Allowable Value
From	To	
P1	PD	15 to 25 ohm
PD	P1	

(From P1 To PD > From PD To P1 ;if RS was opened)

[3] Rectifier Measurement

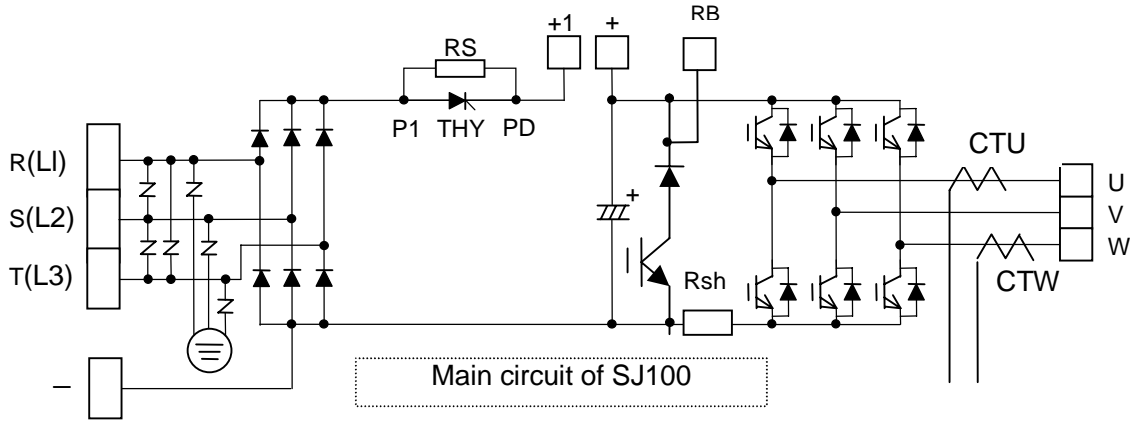

This is to measure 6 rectifiers of the input side.

Resistance Measurement		Allowable Value
From	To	
R(L1)	S(L2)	50kohm or more
S(L2)	R(L1)	
S(L2)	T(L3)	
T(L3)	S(L2)	
T(L3)	R(L1)	
R(L1)	T(L3)	
R(L1)	⊖	
⊖	R(L1)	
S(L2)	⊖	
⊖	S(L2)	
T(L3)	⊖	
⊖	T(L3)	
Each R(L1), S(L2) and T(L3)	-	50kohm or more
-	Each R(L1), S(L2) and T(L3)	50 ohm or less
Each R(L1), S(L2) and T(L3)	P1	50 ohm or less
P1	Each R(L1), S(L2) and T(L3)	50kohm or more

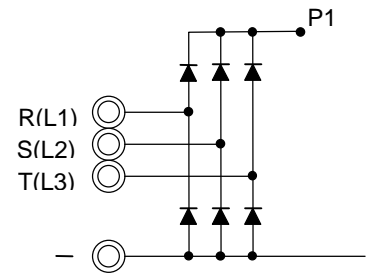

To make sure MOV, visual check of MOV is necessary on the ISPM.

If the result is out of its spec, replace the unit. (relative check is important)

MOV(ZNR);ZNR1,ZNR2,ZNR3 are for phase to phase

MOV(ZNR);ZNR4,ZNR5,ZNR6 are for phase to ground

[4] IGBT Measurement

Resistance Measurement		Allowable Value
From	To	
+	U	50kohm or more
+	V	
+	W	
U	+	50 ohm or less
V	+	
W	+	
-	U	50 ohm or less
-	V	
-	W	
U	-	50kohm or more
V	-	
W	-	

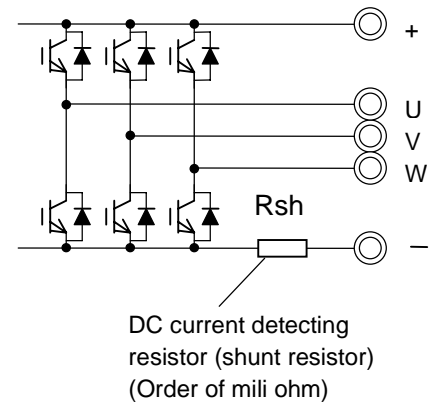

If the result is out of its spec, replace the unit.

Please note that this cannot cover 100% to find IGBT failure because if the power devices in failure, sometimes you can find the failure in components while they are activated. (You cannot find the failure while they are not activated.)

[5] Cooling FAN voltage circuit in the ISPM (PV 24N)

Check “b92” is preset “”00 (FAN to be worked) and disconnect the cooling FAN

Resistance Measurement		Allowable Value
From	To	
Pin(up) (Red)	Pin(down) (Black)	20kohm or more
Pin(up) (Black)	Pin(down) (Red)	50ohm or less

(relative check is important)

[6] Cooling FAN

Disconnect the cooling FAN and measure impedance of FAN circuit.

Resistance Measurement		Allowable Value
From	To	
Red wire	Black wire	50kohm or less
Black wire	Red wire	100kohm or more

(relative check is important)

[7] BRD(RB,+,-)

Disconnect BRD resistor.

Red wire, Black wire mean tester’s wires.

Resistance Measurement		Allowable Value	Allowable Value Diode drop V
+	RB		
Black wire	Red wire	100kohm - 400kohm	0.3 – 0.5
Red wire	Black wire	8ohm – 14ohm	OL

(only reference)

Resistance Measurement		Allowable Value	Allowable Value Diode drop V
RB	-		
Black wire	Red wire	100kohm – 700kohm	OL(initial charge)
Red wire	Black wire	2kohm – 4kohm	OL

(only reference)

7. Maintenance and Inspection Procedure

7-1. Precautions

(1) Maintenance and Inspection Precautions

Be sure to check the followings before starting maintenance and inspection because there is a danger of electrical shock.

- Display on the digital operation panel and POWER indication has been turned OFF.
- The voltage between + and - is 15Vdc or lower.
- Discharging resistor (500 ohm 30W for 200V class, 1k ohm 60W for 400V class) has been connected between + and - terminals for 15 seconds or more after main power had turned off,

(2) General Precautions

- Always keep the unit clean so that no dust nor other foreign materials come inside of the frequency inverter.
- Pay attention to broken lines and faulty connections. Firmly connect terminals and connectors.
- Keep frequency inverter away from moisture and oil.
- Dusts, steel filings, swarf, and other foreign materials can damage insulation and causing unexpected accidents/failure. Please pay attention to them.

7-2. Measurement of Mains Voltage, Current and Power

General measuring instruments for mains voltage, current and power are shown in Table 7-1.

The voltage to be measured is the effective value of fundamental wave, and the power to be measured is the total effective value.

(1) Measurement of output voltage

Moving iron type instrument does not show accurate values for measurement of the output voltage. Make measurements according to the method shown in Fig. 7-3 (table 7-1) or using the circuit indicated in Fig. 7-1 and 7-2.

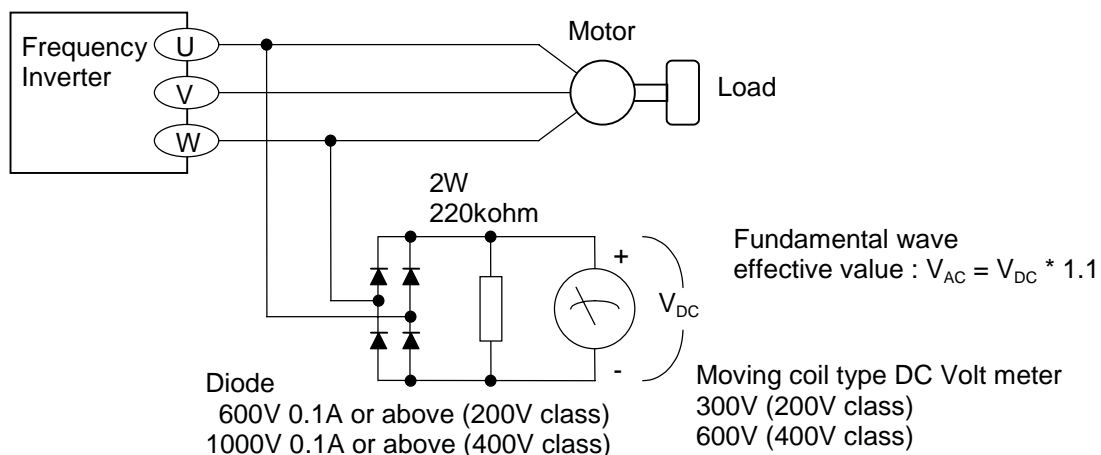

Fig. 7-1. Output voltage measurement circuit (with load)

When there is no motor connected to the inverter, please use additional resistor like Fig. 7-2. There will be a voltage at output terminal even the frequency command is naught due to the leakage current of the semiconductor devices.

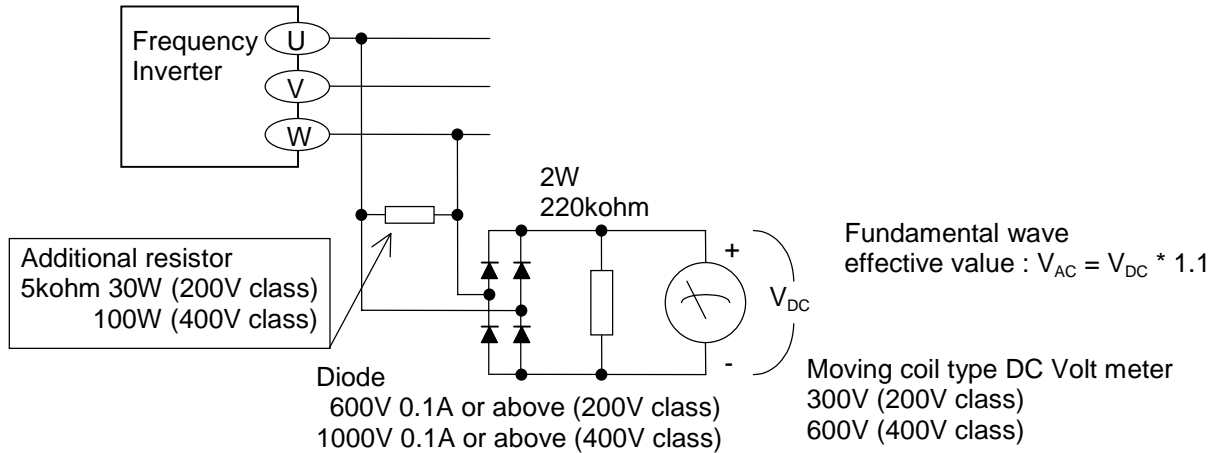

Fig. 7-2. Output voltage measurement circuit (without motor)

(2) Measurement of Input voltage and Input / output current

Use moving iron type ampere meter. (Refer to Fig. 7-3 and Table 7-1.)

(3) Measurement of Input and output power

Use electrodynamic type watt meter for single phase use. Make measurements for all 3 phases is case there is an unbalance in voltages and currents.

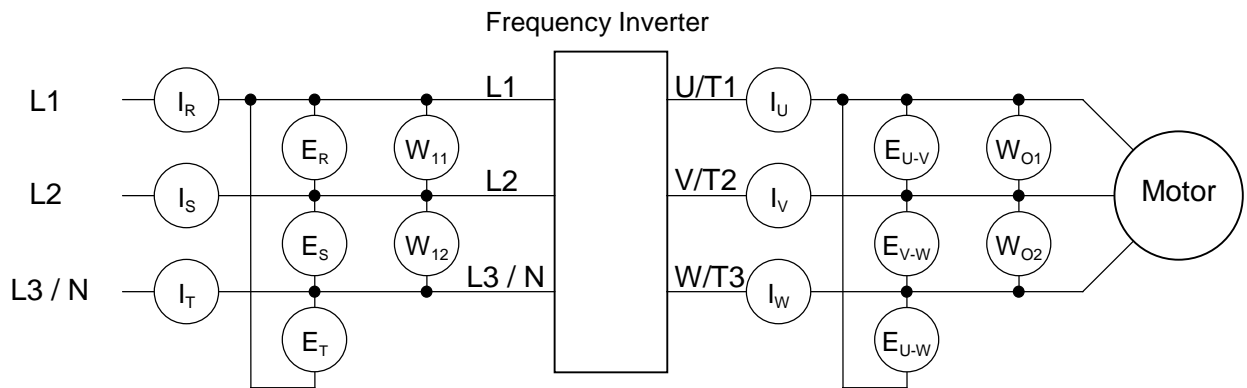







Fig. 7-3. Measurement Instruments

Table 7-1 Measuring Instruments

Item	Instruments	Type of Instrument	Remarks
Supply voltage E1	E_{L1-L2} , E_{L2-L3} and E_{L3-L1}	 Moving iron type voltmeter or  Rectifier type voltmeter	Fundamental wave effective value
Supply current I1	I_{L1} , I_{L2} and I_{L3}	 Moving iron type ammeter	Total effective value
Supply power W1	W_{11} and W_{12}	 Electrodynamic wattmeter	Total effective value
Supply power Factor Pf1	Calculate from above measured values E1, I1 and W1 $Pf1 = \frac{W_1}{\sqrt{3} \cdot E_1 \cdot I_1} \times 100(\%)$		
Output voltage Eo	E_{U-V} , E_{V-W} and E_{W-U}	According to Fig.7-1 and Fig.7-2	Total effective value
Output current Io	I_U , I_V and I_W	 Moving iron type ammeter	Total effective value
Output power Wo	W_{O1} and W_{O2}	 Electrodynamic wattmeter	Total effective value
Output power factor Pf2	Calculate from above measured values Eo, Io and Wo $Pf1 = \frac{W_o}{\sqrt{3} \cdot E_o \cdot I_o} \times 100(\%)$		

NOTE : Use a meter indicating a fundamental wave effective value for voltage, and meters indicating total effective values for current and power.

7-3. Maintenance of Parts

(1) Maintenance of printed circuit board (I/O board)

Printed circuit boards are maintenance free under normal applications except ALARAM relay (hardware). However, in case which maintenance and inspection are necessary, pay attention to the prevention of damage caused by static electricity as shown below.

* Prevent damage caused by static electricity

MCU and LSI on the printed circuit board can be destroyed by static electricity. Therefore be sure to ground work benches, soldering irons and yourself before start working on a printed circuit board.

(2) Maintenance of DC bus capacitor and cooling fan

We recommend that DC bus capacitors and cooling fans to be regularly replaced every three years taking their lives into account. Please note that their life span shorten when they are used in high temperatures and heavy loads.

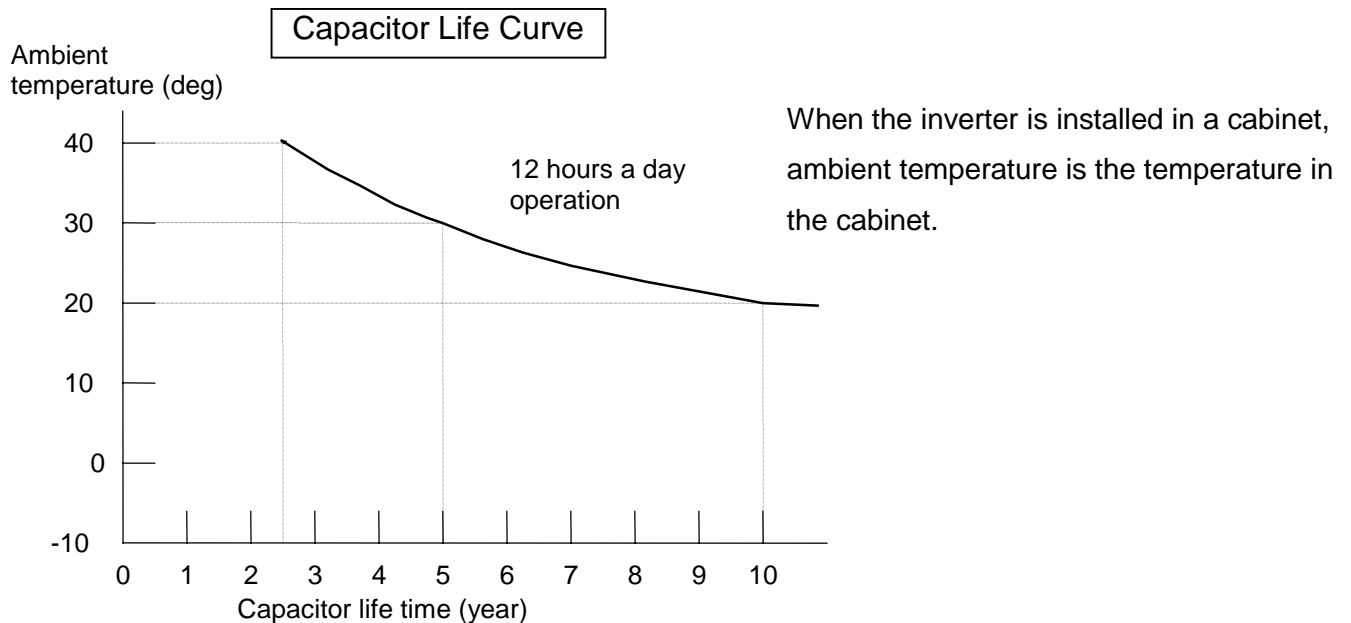

7-4. If you install replacement INV at site

If you install replacement units at site, please preset the parameter by the panel or copy unit.

If you used the previous I/O board to replacement unit, the parameters are not changed.

Because parameters are memorized in the EEPROM on the control board on J100 /J300 series, and if we used the previous control board to replacement unit at site to minimize the time. In case of L100,SJ100 series, EEPROM is on the ISPM, even we replaced I/O board, the parameter is still the same.

8. Daily Inspection and Periodical Inspection

Inspection point	Item	Contents	Cycle		Method	Criteria	Standard replacement period	Instruments
			daily	periodic				
Overall	Ambient Environment	Check ambient temperature, humidity, dust, corrosive gas, oil mist, etc.	✓			Ambient temperature : -10deg to 40deg, no icing		Thermometer
	Devices overall	Check for abnormal vibrations and noise.	✓		Visual and aural inspection			Hygrometer
	Power supply voltage	Check voltage between input lines.	✓		Measure the voltage between input terminals	No abnormalities. Within its specification		Tester
Main circuit	Overall	Check installation for looseness.		✓	Tighten	Tightening torque (except for terminal block) M3: 0.5 - 0.6 N-m M4: 0.98 - 1.3 N-m		
		Check for evidence of over heating in the various components		✓	Visual inspection			
		Clean		✓				
	Terminal block	No damage		✓	Visual inspection	No abnormalities		
	DC bus capacitor	Check for leaking liquid	✓		Visual inspection	No abnormalities		
		Check for swelling						
	Relay	Check for stuttering noise when operation		✓	Aural inspection	No abnormalities		
	Resistors	Check for cracks or changes in color		✓	Visual inspection	No abnormalities		Tester
Cooling fan	Check for abnormal vibration and noise	✓		-Rotate manually while power off -Increase tightening	- Smooth rotation - No abnormalities	2 - 3 years		
	Check for dust	✓		Visual inspection				

Inspection point	Item	Contents	Cycle		Method	Criteria	Standard replacement period	Instruments
			daily	periodic				
Control circuit	Operation check	Check the balance of the output voltage of each phase to phase without motor.		✓	Measure the output voltage between U, V and W	Within 2% of voltage difference between each phases.		See next page
		Perform a sequence protection operation test and make sure that there are no errors in the protection and display circuits.		✓	Simulate operation of the protection circuit	Operate without any trouble		
	Component check including PCB	No abnormal odor nor changes in color.		✓	Visual inspection	No abnormalities		
		No significant corrosion.		✓				
	Capacitors on I/O board	No liquid leakage nor deformation.	✓		Visual inspection	No abnormalities		
Display	Digital operation panel	- No illegible display - No lack of character - Segment failure of LEDs	✓		Visual inspection	Normal operation. Display is readable.		

- NOTE : 1. Life time of capacitor is affected by the ambient temperature. See Capacitor Life Curve in the following.
2. The frequency inverter must be cleaned periodically. If dust accumulates on the fan and heat sink, it can cause overheating.
3. See item 7-3 (2) for the life time of the capacitor.

9. Image block diagram

(1). IMAGE BLOCK DIAGRAM OF SJ100 INVERTER

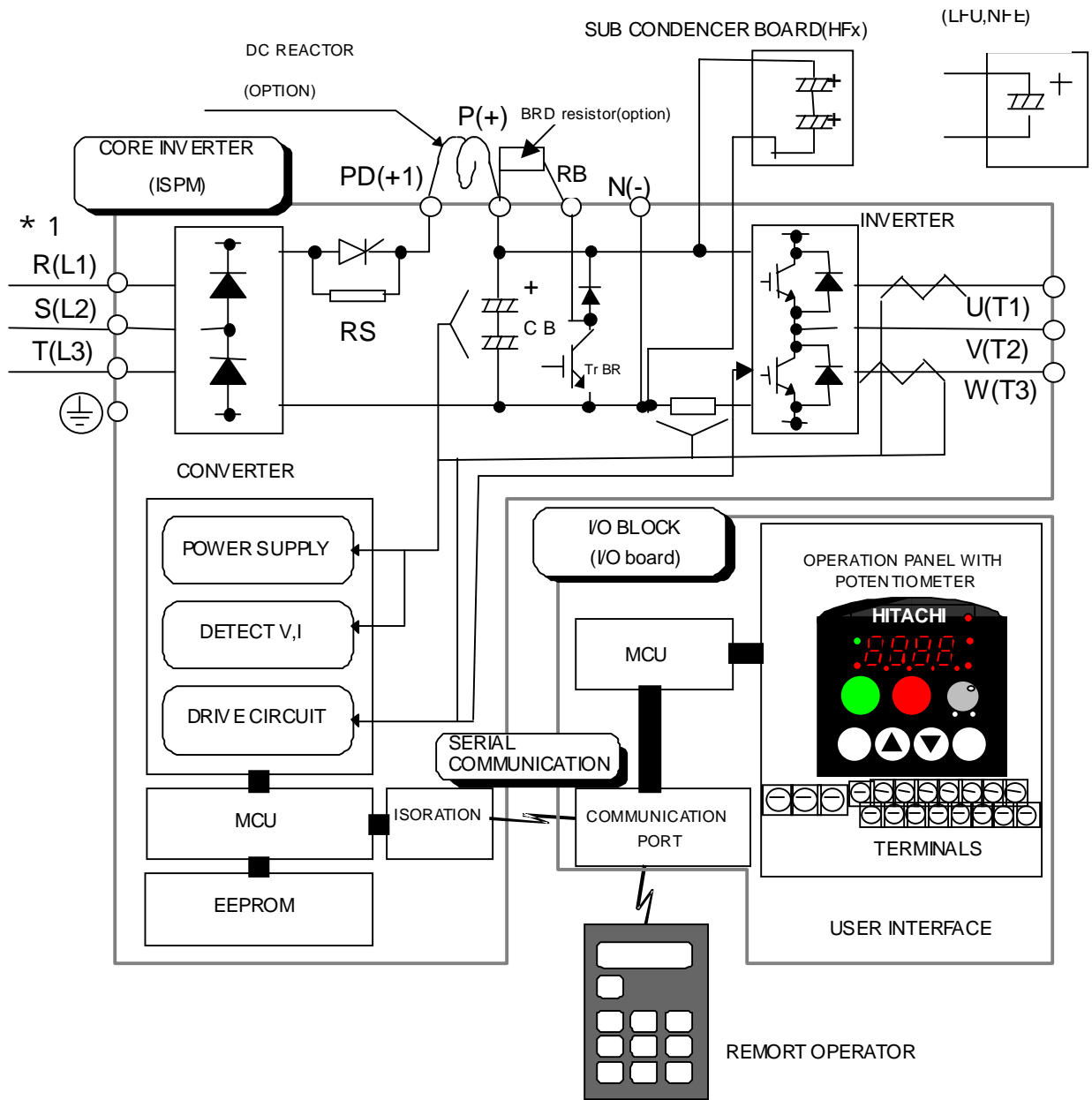

EMC DIRECTIVE COMPLIANT WITH DEDICATED NOISE FILTER(OPTION)

Note; Main circuit capacitor CB; HFE,HFU; serial connection.

; LFU,NFE; single connection.

10-1. Spare Parts list

No.	Class	Parts Code	DWG.No.	Parts Name	Remarks	Quantity	Lot
1	D	254858	2T004556 1	Key PAD (HITACHI)	For all models	1	10
2	D	254857	2T004372 4	Front case (S)	SJ100-002-007LFR SJ100-002-005NFE SJ100-002,004NFU	1	10
2	D	254855	1T001784 4	Front case (L)	SJ100-015-075LFR SJ100-007-022NFE SJ100-007-022NFU SJ100-037-075LFU SJ100-004-075HFR SJ100-004-075HFE;HFU	1	10
3	D	254859	3T015677 7	Key cover	For all models	1	10
4	D	254864	4T013420 4	Volume KNOB	For all models	1	10
5	D	254863	4T013419 4	Top cover (S)	SJ100-002-007LFR SJ100-002-005NFE SJ100-002,004NFU	1	10
5	D	254865	4T013459 4	Top cover (L)	SJ100-015-037LFR SJ100-007-022NFE SJ100-007-022NFU SJ100-037LFU SJ100-004-037HFR SJ100-004-040HFE;HFU	1	10
5	D		3T016369 4	Top cover (LL)	SJ100-055,075LFU;HFE;HFU,LFR,HFR	1	10
6	D	254856	2T004371 4	Case (S)	SJ100-002-007LFR SJ100-002-005NFE SJ100-002,004NFU	1	10
6	D	254854	1T001783 4	Case (M)	SJ100-015,022LFR SJ100-007,011NFE SJ100-007NFU SJ100-004-022HFR SJ100-004-022HFE SJ100-004-022HFU	1	10
6	D	254853	1T001782 4	Case (L)	SJ100-037LFR SJ100-015,022NFE SJ100-015,022NFU SJ100-037LFU SJ100-037HFR SJ100-030,040HFE SJ100-040HFU	1	10

6	D		1T001858 4	Case (LL)	SJ100-055,075LFU;HFE;HFU,LFR,HFR	1	10
7	D	254862	4T013417 4	Rear cover (S)	SJ100-002-007LFR SJ100-002-005NFE SJ100-002,004NFU	1	10
7	D	254860	3T015700 4	Rear cover (L)	SJ100-015-037LFR SJ100-007-022NFE SJ100-007-022NFU SJ100-037LFU SJ100-004-037HFR SJ100-004-040HFE;HFU	1	10
7	D		3T016368 4	Rear cover (LL)	SJ100-055,075LFU;HFE;HFU,LFR,HFR	1	10
8	D	254861	3T015710 4	Condensor cover (L)	SJ100-037LFR SJ100-015,022NFE SJ100-015,022NFU SJ100-037LFU ,037HFR SJ100-030,040HFE SJ100-040HFU	1	10
8	D		2T004495 4	Condensor cover (LL)	SJ100-055,075LFU;HFE;HFU,LFR,HFR	1	10

No.	Class	Parts Code	DWG.No.	Parts Name	Remarks	Quantity	Lot
9	C	254270	3T012518 2	Cooling fan(S)	SJ100-015,022LFR;HFR SJ100-015,022HFE;HFU SJ100-055LFR;LFU	1	3
9	C	254270	3T012518 2	Cooling fan(S)	SJ100-075LFU,LFR	2	3
9	D	254822	3T011924 4	Cooling fan(L)	SJ100-022NFE;NFU SJ100-037LFR;LFU;HFR SJ100-030HFE SJ100-040HFE;HFU	1	3
10	D	254827	4T013337 1	ISPM-IO Cable (S)	SJ100-002-037LFR SJ100-002-022NFE;NFU SJ100-037LFU SJ100-004-037HFR SJ100-004-040HFE;HFU	1	10
10		254828	4T013337 4	ISPM-IO Cable (L)	SJ100-055,075LFU,HFE;HFU,LFR,HFR	1	10
11		---	3T016869 3	ISPM (without PCB2)	SJ100-002LFR;NFE;NFU	1	1
11		--	3T016870 3	ISPM (without PCB2)	SJ100-004LFR;NFE;NFU, SJ100-005NFE	1	1
11		--	3T016871 3	ISPM (without PCB2)	SJ100-007LFR	1	1
11		--	3T016872 3	ISPM (without PCB2)	SJ100-007NFE;NFU SJ100-011NFE	1	1

11		--	3T016873 3	ISPM (without PCB2)	SJ100-015LFR;NFE;NFU	1	1
11		--	3T016874 3	ISPM (without PCB2)	SJ100-022LFR;NFE;NFU	1	1
11		--	3T016875 3	ISPM (without PCB2)	SJ100-037LFR;LFU	1	1
11		--	3T017100 2	ISPM (without PCB2)	SJ100-055LFR;LFU	1	1
11		--	3T017101 2	ISPM (without PCB2)	SJ100-075LFR;LFU	1	1
11		--	3T016876 2	ISPM (without PCB2)	SJ100-004HFR;HFE;HFU	1	1
11		--	3T016877 2	ISPM (without PCB2)	SJ100-007HFR;HFE;HFU	1	1
11		--	3T016878 2	ISPM (without PCB2)	SJ100-015HFR;HFE;HFU	1	1
11		--	3T016879 2	ISPM (without PCB2)	SJ100-022HFR;HFE;HFU	1	1
11		--	3T016880 2	ISPM (without PCB2)	SJ100-037HFR SJ100-030HFE SJ100-040HFE;HFU	1	1
11		--	3T017102 2	ISPM (without PCB2)	SJ100-055HFR;HFE;HFU	1	1
11		--	3T017103 2	ISPM (without PCB2)	SJ100-075HFR;HFE;HFU	1	1
12		254890	4T013548 1	RS(soft charge resistor)	SJ100-002--022NFE;NFU SJ100-037,055LFU SJ100-002-055LFR SJ100-004--055HFE;HFU,HFR	1	10
12		254890	4T013548 1	RS(soft charge resistor)	SJ100-075HFE;HFU;LFU,LFR,HFR	2	10
13		--	4T013438 1	Copper bar	SJ100-002-007LFR SJ100-002,004NFE;NFU,005NFE	1	10
13		--	4T013439 1	Copper bar	SJ100-015-037LFR SJ100-007--022NFE,NFU SJ100-007--022NFU,037LFU SJ100-004-037HFR SJ100-004--040HFE;HFU	1	10
14		--	SJ100L	I/O board	SJ100-002-037LFR;HFR		
14		--	SJ100EUL	I/O board	SJ100-002--022NFE;NFU SJ100-037LFU SJ100-004--040HFE;HFU	1	1
14		--	SJ100UL (only label change)	I/O board (from '99 Oct. production)	SJ100-002-022NFU,037LFU SJ100-004-040HFU	1	1
14		--	SJ100075L	I/O board	SJ100-055,075LFR;HFR	1	1
14		---	SJ100075EUL	I/O board	SJ100-055,075LFU;HFE;HFU	1	1

15		--	CB470	Capacitor board	SJ100-037HFR,030HFE SJ100-040HFE,HFU	1	1
15		--	CB68X4H	Capacitor board	SJ100-055HFR,HFE,HFU	1	1
15		--	CB68X6H	Capacitor board	SJ100-075HFR,HFE;HFU	1	1
16		--	SJCB180A	PCB2	SJ100-002LFR	1	1
16		--	SJCB330A	PCB2	SJ100-004LFR	1	1
16		--	SJCB680A	PCB2	SJ100-007LFR	1	1
16		--	SJCB470B2	PCB2	SJ100-015LFR	1	1
16		--	SJCB680B2	PCB2	SJ100-022LFR;011NFE		
16		--	SJCB2330A	PCB2	SJ100-002NFE;NFU		
16		---	SJCB2680A	PCB2	SJ100-004NFE;NFU, 005NFE	1	1
16		---	SJCB560B2	PCB2	SJ100-007NFE;NFU	1	1
16		---	SJCB470B2T	PCB2	SJ100-015NFE;NFU, 037LFR;LFU	1	1
16		---	SJCB680B2T	PCB2	SJ100-022NFE;NFU	1	1
16		--	L100SB055L	PCB2	SJ100-055LFR;LFU	1	1
16		--	L100SB075L	PCB2	SJ100-075LFR;LFU	1	1
16		--	SJCB180B4	PCB2	SJ100-004HFR;HFE;HFU	1	1
16		---	SJCB270B4	PCB2	SJ100-007HFR;HFE;HFU	1	1
16		---	SJCB470B4	PCB2	SJ100-015HFR;HFE;HFU	1	1
16		---	SJCB680B4	PCB2	SJ100-022HFR;HFE;HFU	1	1
16		---	SJCB470B4T	PCB2	SJ100-037HFR,030HFE SJ100-040HFE,HFU	1	1
16		---	L100SB055H	PCB2	SJ100-055HFR;HFE;HFU	1	1
16		---	L100SB075H	PCB2	SJ100-075HFR;HFE;HFU	1	1

Note No.10 4T013337 3 is usable for 4T01337 4. The difference is the length.

No.13 The copper bar is used between ISPM and heatsink.

C/H version is applied US version except key pad/knob/cover/case etc.

This spare parts list will be changed without notice. To get latest spare parts list, please contact to sales office.

This service manual may not be revised if the spare parts list was revised.

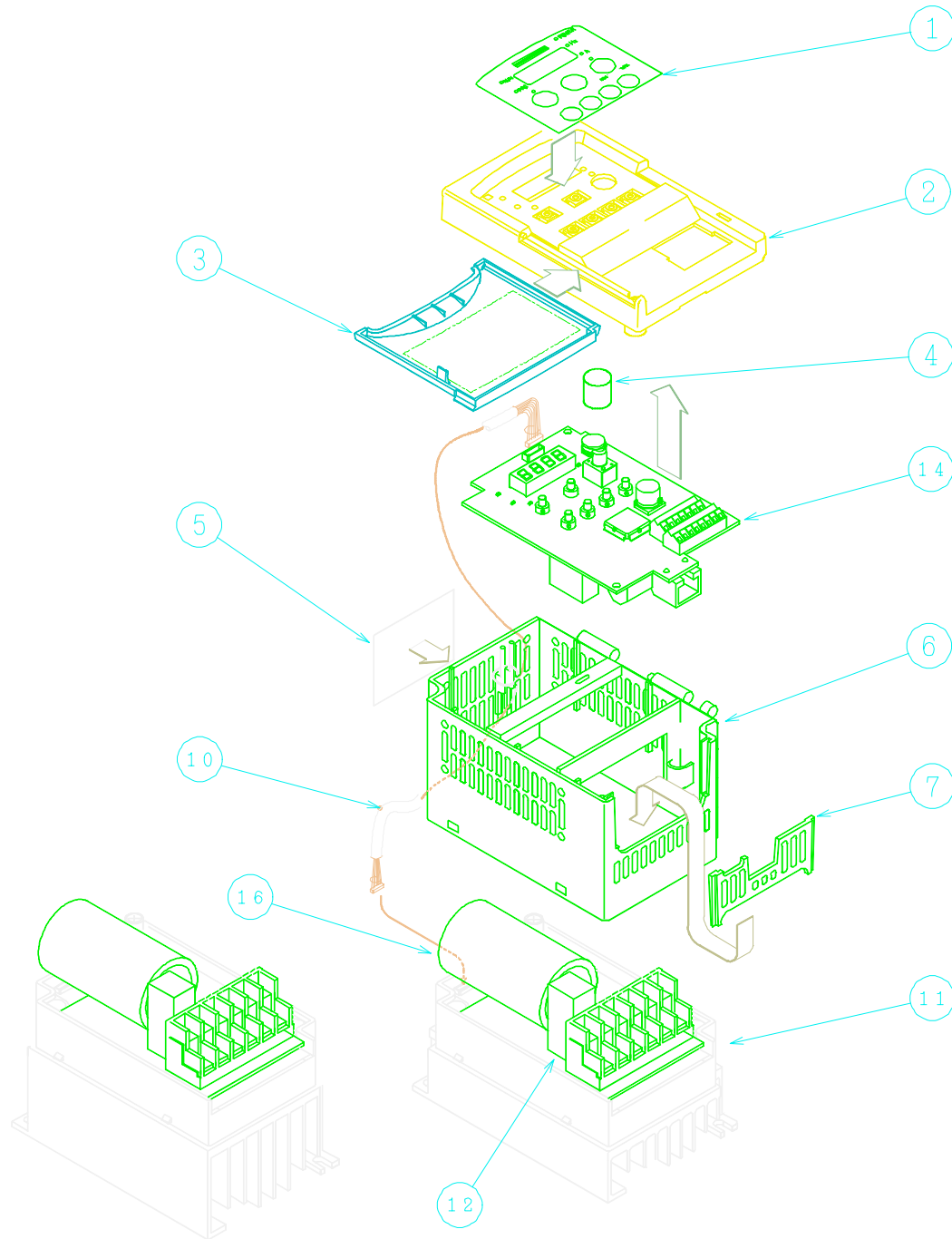

No.	Parts name	Quantity
1	Keypad	1
2	Front case (L)	1
3	Key cover	1
4	Volume knob	1
5	Top cover (S)	1
6	Case (S)	1
7	Rear cover (S)	1
10	ISPM - IO cable (S)	1
11	ISPM	1
12	RS	1
14	I/O board	1
16	PCB2	1

SJ100-002NFE

002NFU

004NFE

004NFU

005NFE

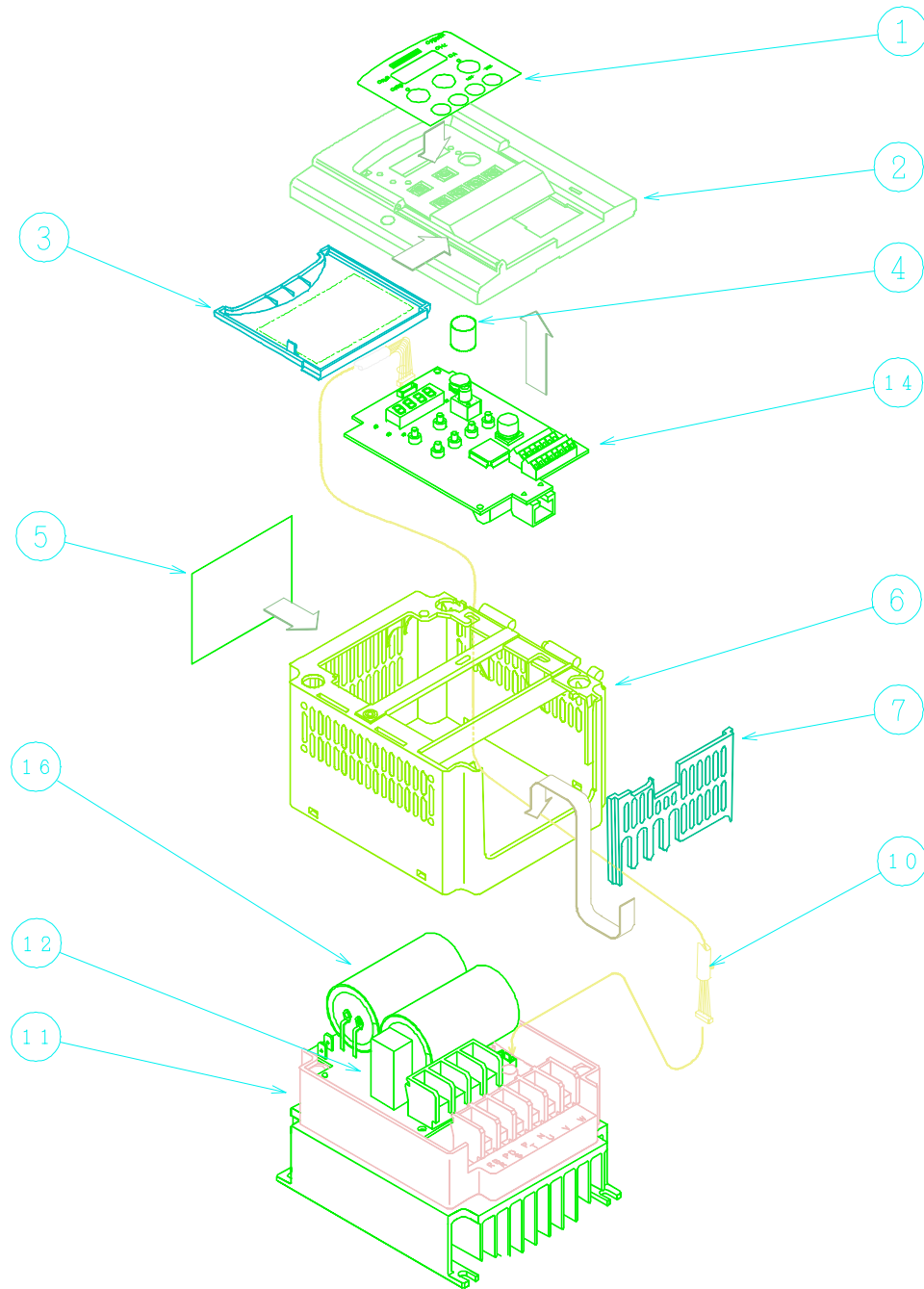

No.	Parts name	Quantity
1	Keypad	1
2	Front case (L)	1
3	Key cover	1
4	Volume knob	1
5	Top cover (L)	1
6	Case (M)	1
7	Rear cover (L)	1
10	ISPM – IO cable (L)	1
11	ISPM	1
12	RS	1
14	I/O board	1
16	PCB2	1

SJ100-004HFE
 004HFU
 007NFE
 007NFU
 011NFE

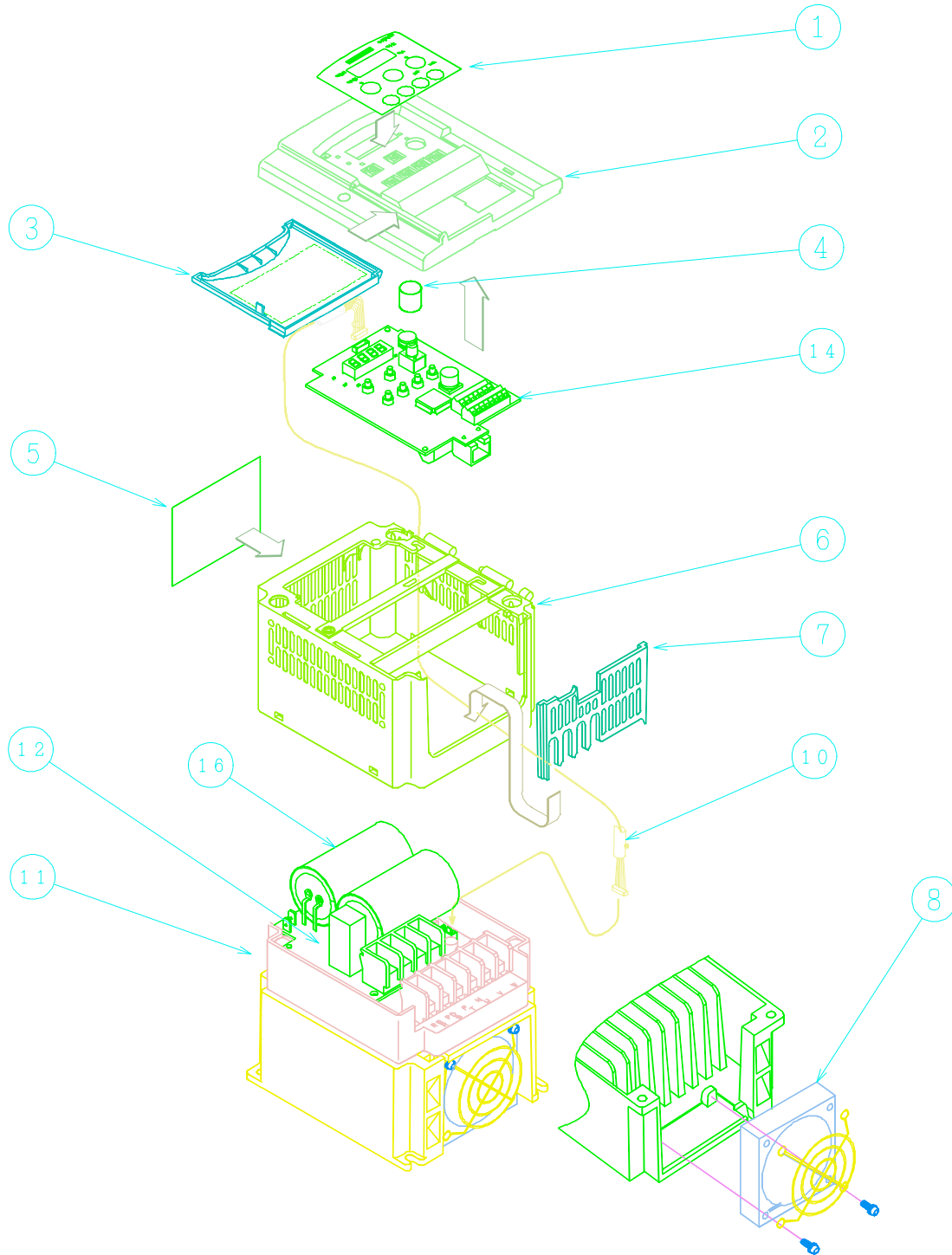

No.	Parts name	Quantity
1	Keypad	1
2	Front case (L)	1
3	Key cover	1
4	Volume knob	1
5	Top cover (L)	1
6	Case (M)	1
7	Rear cover (L)	1
8	Cooling fan (L)	1
10	ISPM - IO cable (L)	1
11	ISPM	1
12	RS	1
14	I/O board	1
16	PCB2	1

SJ100-007HFE
 007HFU
 015HFE
 015HFU
 022HFE
 022HFU

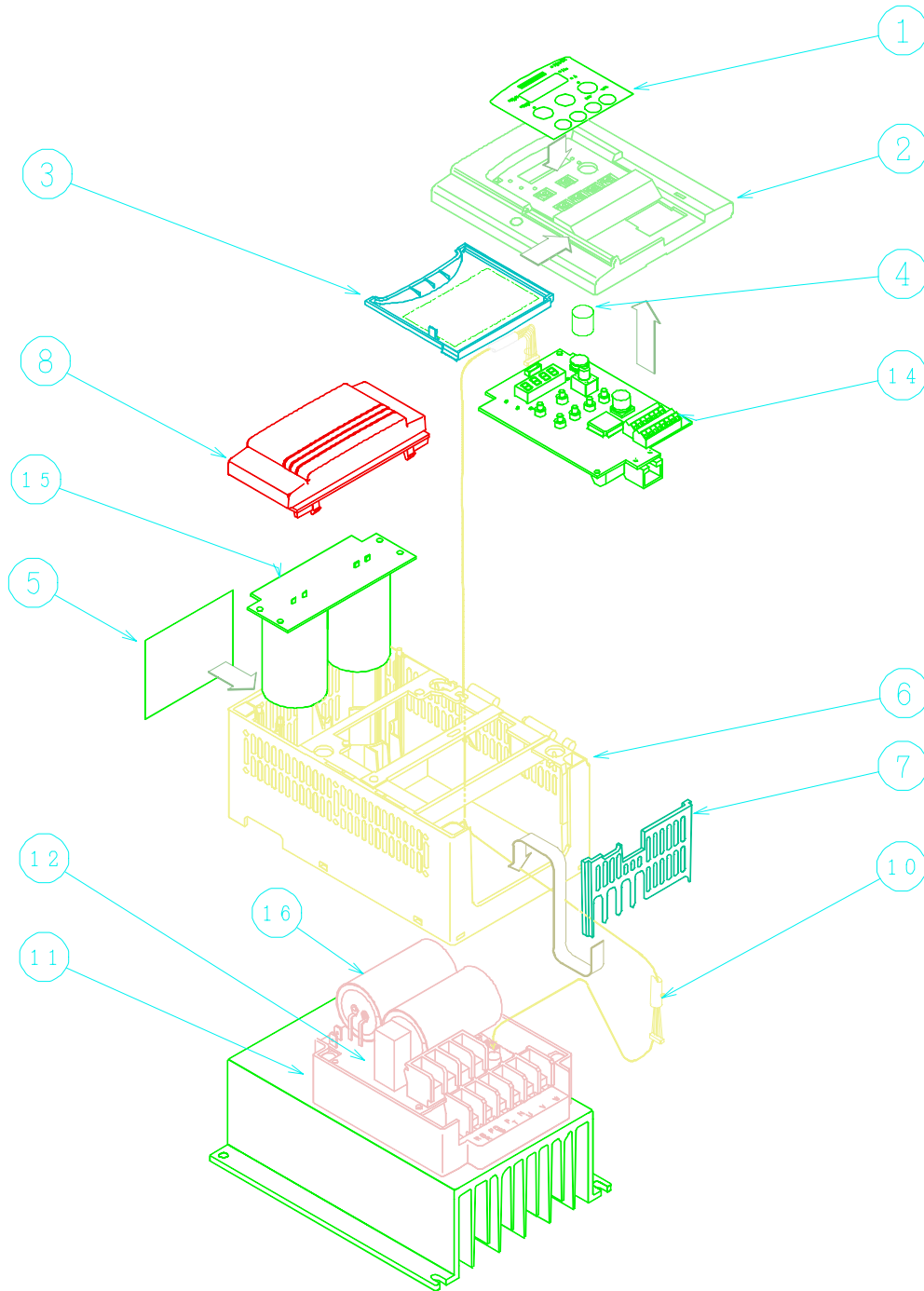

No.	Parts name	Quantity
1	Keypad	1
2	Front case (L)	1
3	Key cover	1
4	Volume knob	1
5	Top cover (L)	1
6	Case (L)	1
7	Rear cover (L)	1
8	Condensor cover	1
10	ISPM - IO cable (L)	1
11	ISPM	1
12	RS	1
14	I/O board	1
15	Capacitor board	1
16	PCB2	1

SJ100-015NFE
015NFU

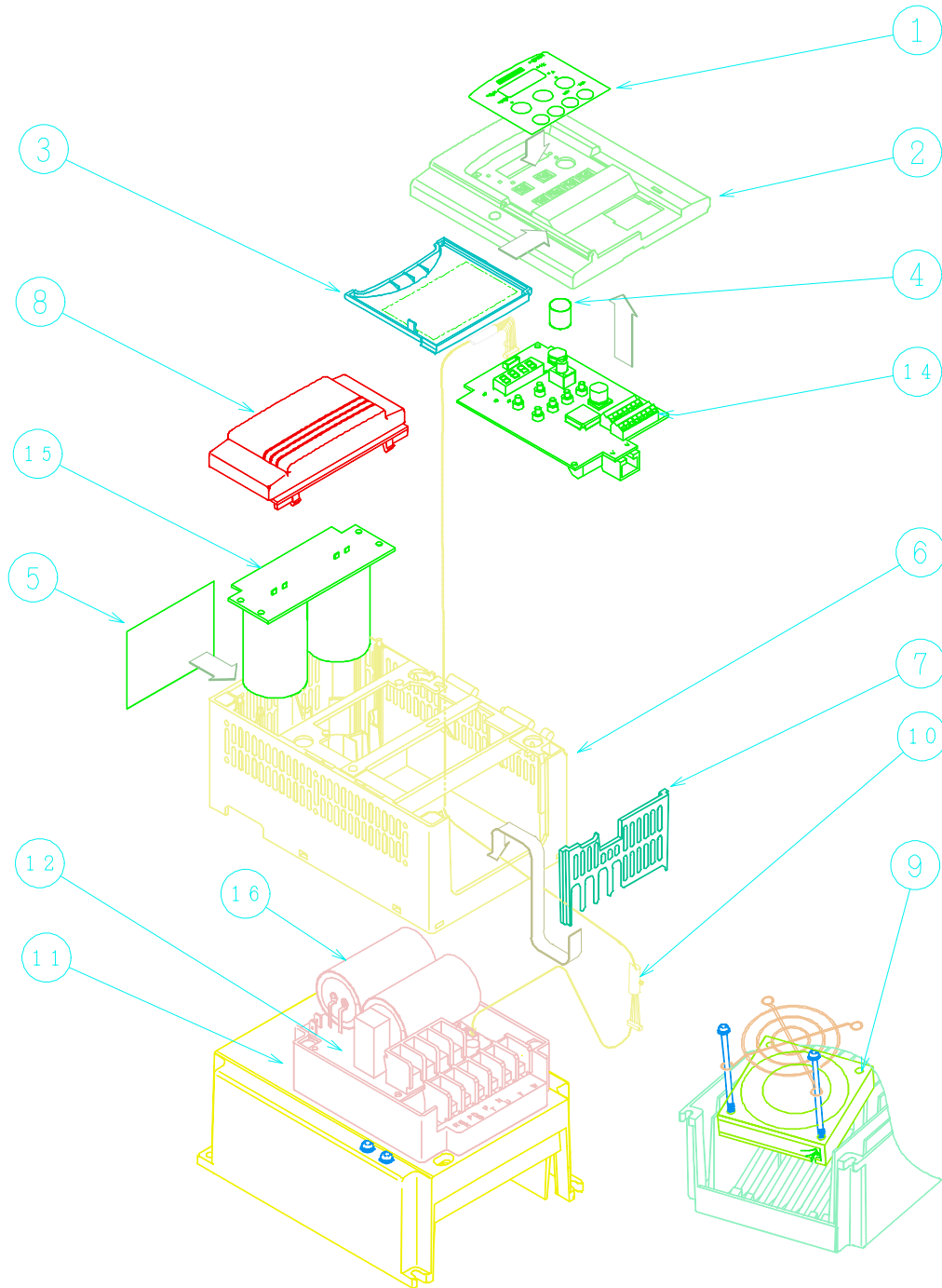

No.	Parts name	Quantity
1	Keypad	1
2	Front case (L)	1
3	Key cover	1
4	Volume knob	1
5	Top cover (L)	1
6	Case (L)	1
7	Rear cover (L)	1
8	Condensor cover	1
9	Cooling fan (L)	1
10	ISPM - IO cable (L)	1
11	ISPM	1
12	RS	1
14	I/O board	1
15	Capacitor board	1
16	PCB2	1

SJ100-022NFE

022NFU

030HFE

037LFU

040HFE

040HFU

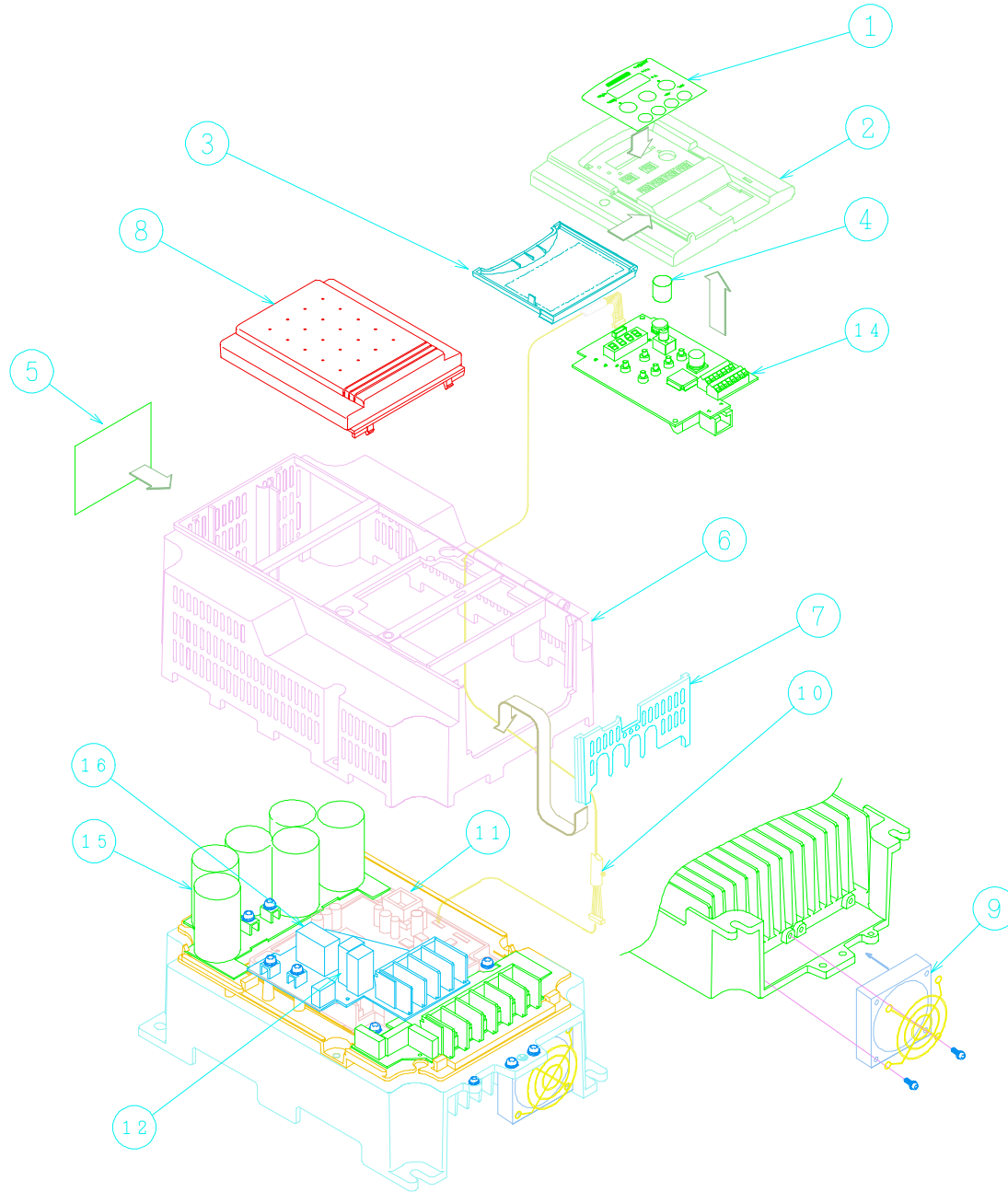

No.	Parts name	Quantity
1	Keypad	1
2	Front case (L)	1
3	Key cover	1
4	Volume knob	1
5	Top cover (LL)	1
6	Case (LL)	1
7	Rear cover (LL)	1
8	Condensor cover (LL)	1
9	Cooling fan (S)	1
10	ISPM – IO cable (L)	1
11	ISPM	1
12	RS	1
14	I/O board	1
15	Capacitor board	1
16	PCB2	1

SJ100-055LFU

055HFU

075HFU

055HFE

075HFE

055LFE

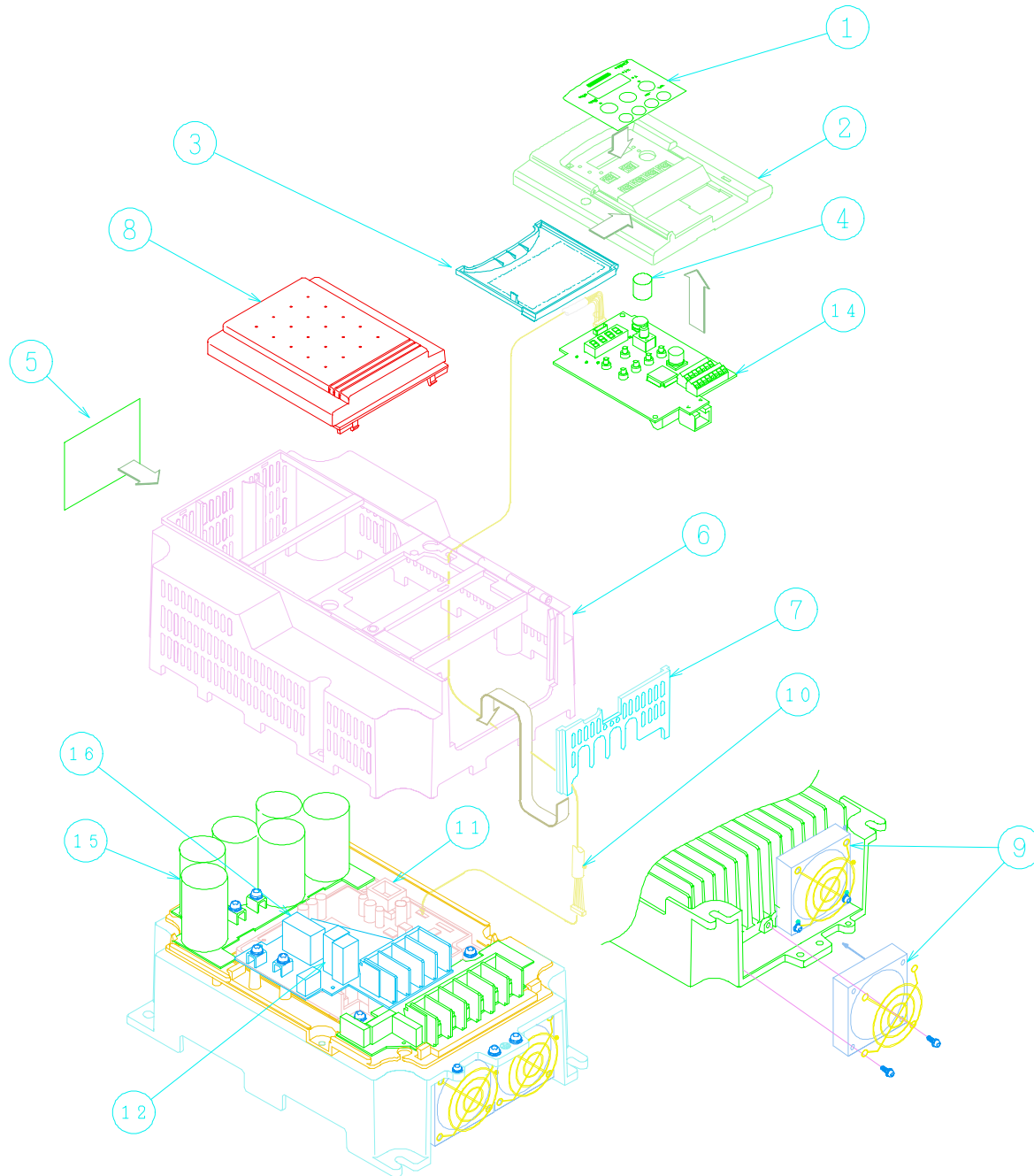

No.	Parts name	Quantity
1	Keypad	1
2	Front case (L)	1
3	Key cover	1
4	Volume knob	1
5	Top cover (LL)	1
6	Case (LL)	1
7	Rear cover (LL)	1
8	Condensor cover (LL)	1
9	Cooling fan (S)	2
10	ISPM - IO cable (L)	1
11	ISPM	1
12	RS	1
14	I/O board	1
15	Capacitor board	1
16	PCB2	1

SJ100-075LFU
075LFE

10-2. I/O board compatibility

V: available - : not available

I/O board Name "Revision"	002NFE-022NFE 037LFE 004HFE-040HFE	002NFR-022NFR 037LFU 004HFU-040HFU	055HFE,075HFE 055LFU,075LFU 055HFU,075HFU	002LFR-037LFR 004HFR-037HFR	055LFR,075LFR 055HFR,075HFR
SJ100EUL "C","D","H"	V	-	-	-	-
SJ100EUL "E","F","G","H"	-	V	-	-	-
SJ100075EUL "A"	-	-	V	-	-
SJ100L "C","D","H"	-	-	-	V	-
SJ100075L "A"	-	-	-	-	V

Note;

"SJ100xxxEUx" ; "SOURCE type" on the control terminal(different from SINK).

"SJ100xxxL" ; "SINK type" on the control terminal.(different from SOURCE)

kW setup is not necessary such as J100 , J300 series for I/O board if I/O board was replaced.

There is no compatibility between L100 series and SJ100 series.

10-3. O,Ol terminal adjustment procedure

If you need the fine adjustment with out F31 IN EX%S, IN EX%E function(DOP/DRW), or A group A13,A14 function (on standard panel), refer to following procedure.

At first, stop the SJ100, and erase the INV trip (error) to change parameters.

O terminal adjustment

Supply the DC10 [V] and if the freq. Setting(F01) is not enough max freq. , increase “C81” value and press the “STR” key and check the result. If the freq. Setting (F01) is not enough, continue the above procedure.

Ol terminal adjustment

Supply the DC20 [mA] and if the freq. Setting(F01) is not enough max freq. , increase “C82” value and press the “STR” key and check the result. If the freq. Setting (F01) is not enough, continue the above procedure.

If the data was added, the freq. setting will be increased. (concept is as same as J100,J300)

“C81” and “C82” are possible to preset while INV running.

10-4. kW setup procedure

To set up kW, we advise you not to use DOP/DRW !, use only standard panel.

Meaning

set C91 "01" ; Debug on
set C94 "D000" ; kW address
set C95 "xx" ; kW code
set B84 "01" ; to execute FACTORY SETTING
Try FACTORY SETTING

Check B12' display (F-23 E-THM LVL)

B12's display table

kW	200V	400V
002	1.40	----
004	2.60	1.50
005,007	4.00	2.50
011,015	7.10	3.80
022	10.00	5.50
030,040	15.90	8.60
055	24.0	13.0
075	32.0	16.0

kW code table (common L100/SJ100)

xx	kW
01	002
02	004
03	005,007
04	011,015
05	022
06	030,040
07	055
08	075

In case of L100, SJ100, it automatically detects it's voltage class with hardware in the ISPM, voltage class setup is not necessary.

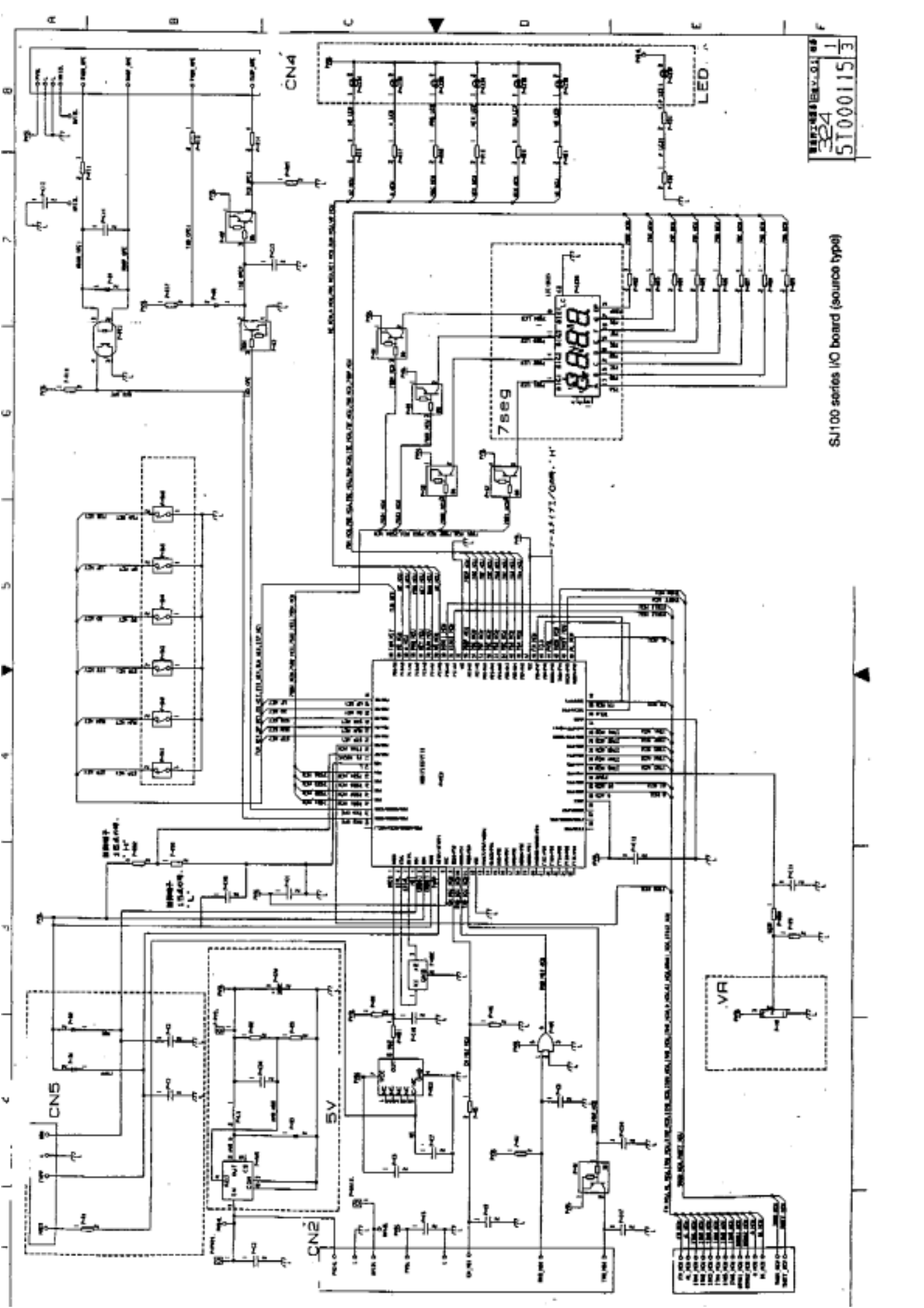

REV. 01 88
324
5T000115 1/3

SJ100 series I/O board (source type)

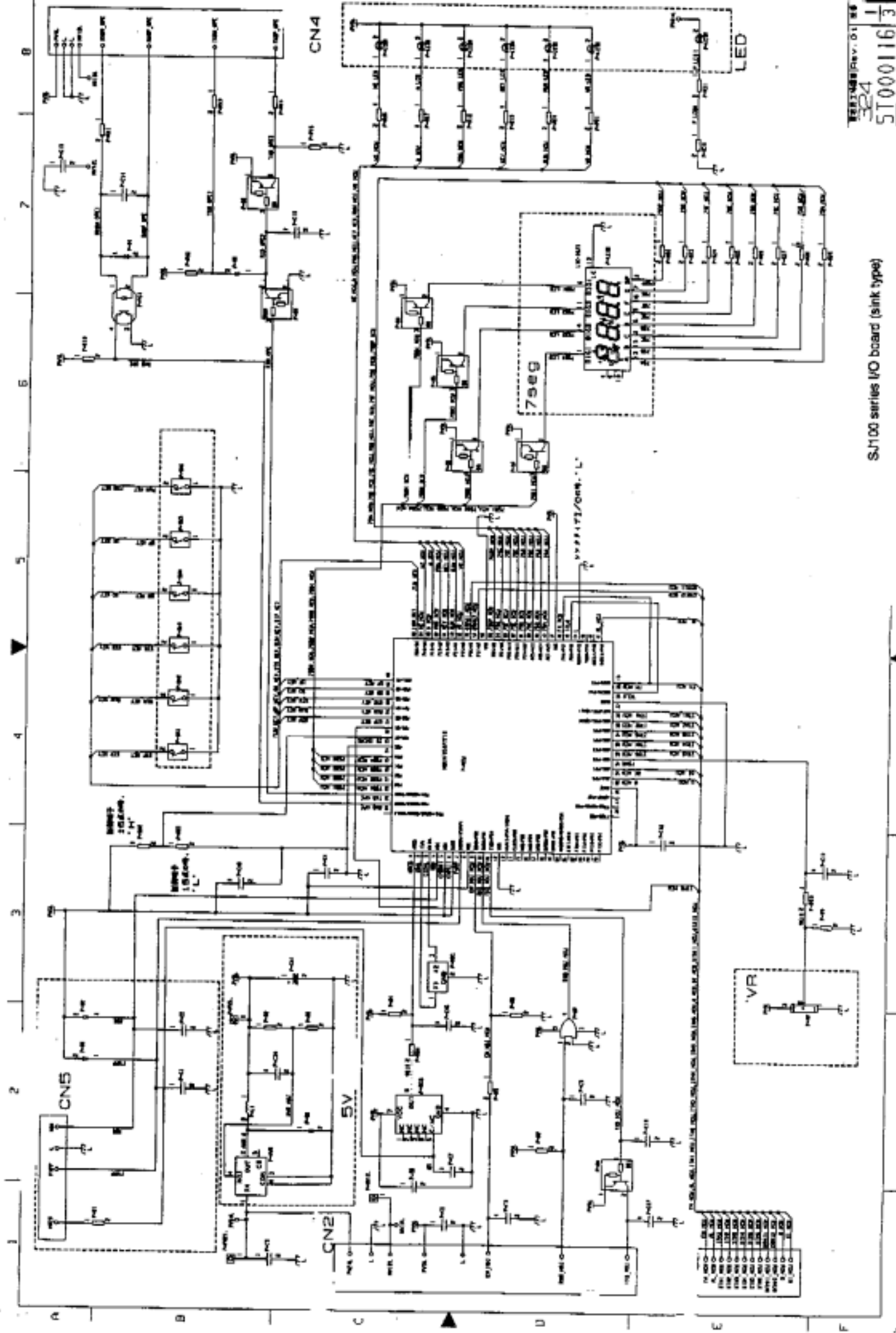

SJ100 series I/O board (sink type)

1 2 3 4 5 6 7 8

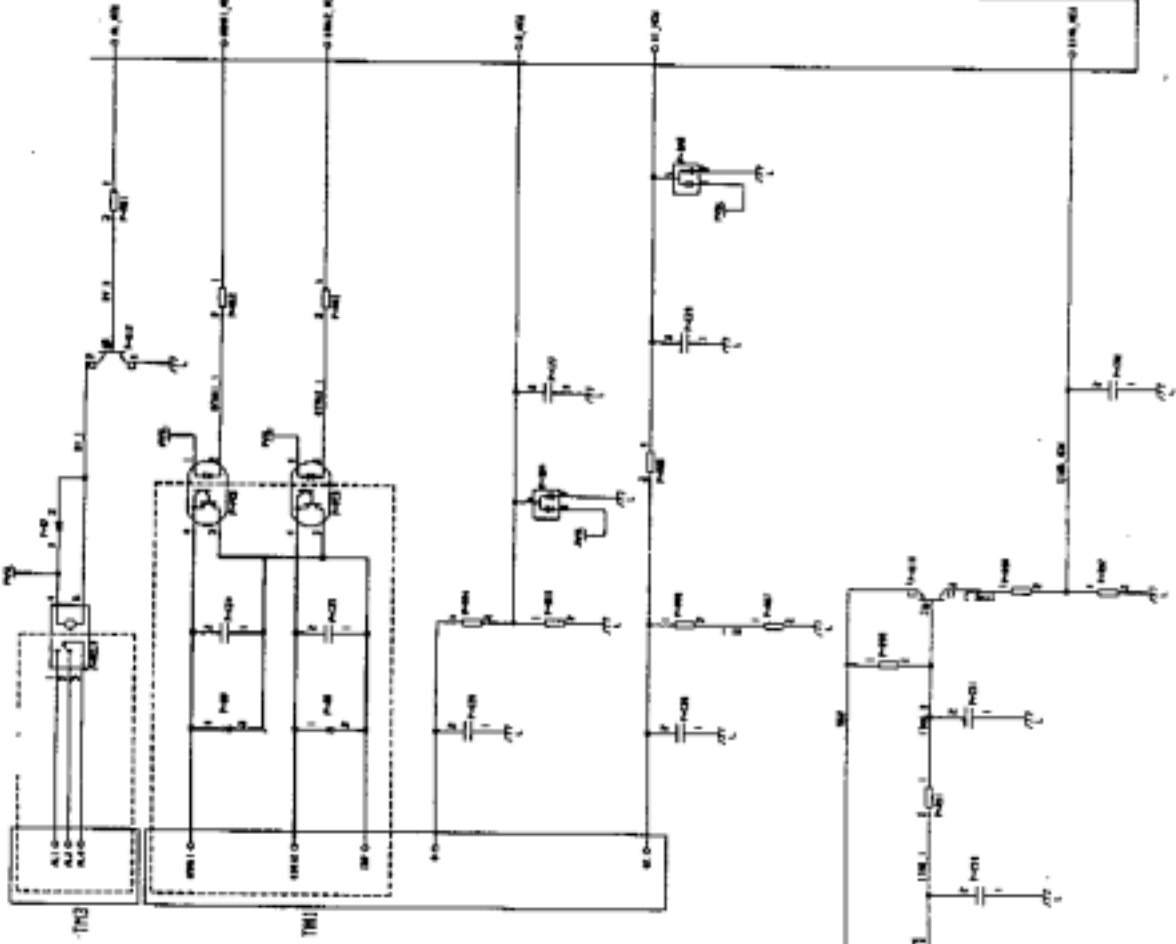
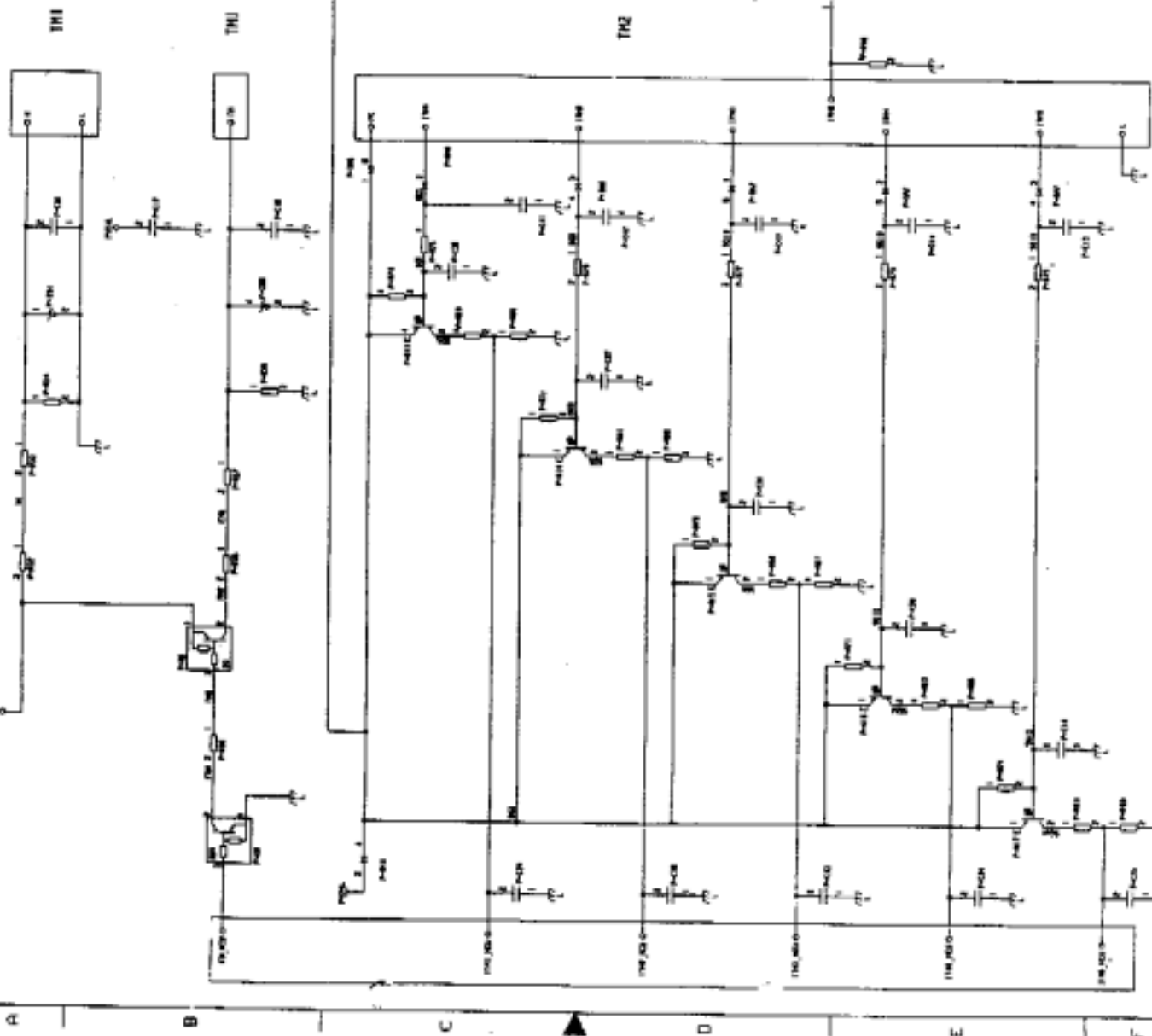

SJ100 series I/O board (sink type)

REV. 01 2
324
5T000116 3

1 2 3 4 5 6 7 8

(TH1)



(TH2A)



(TH2B)

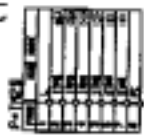

(TH3)



(CN7)



(CN4)



(CN2)



(CN5)



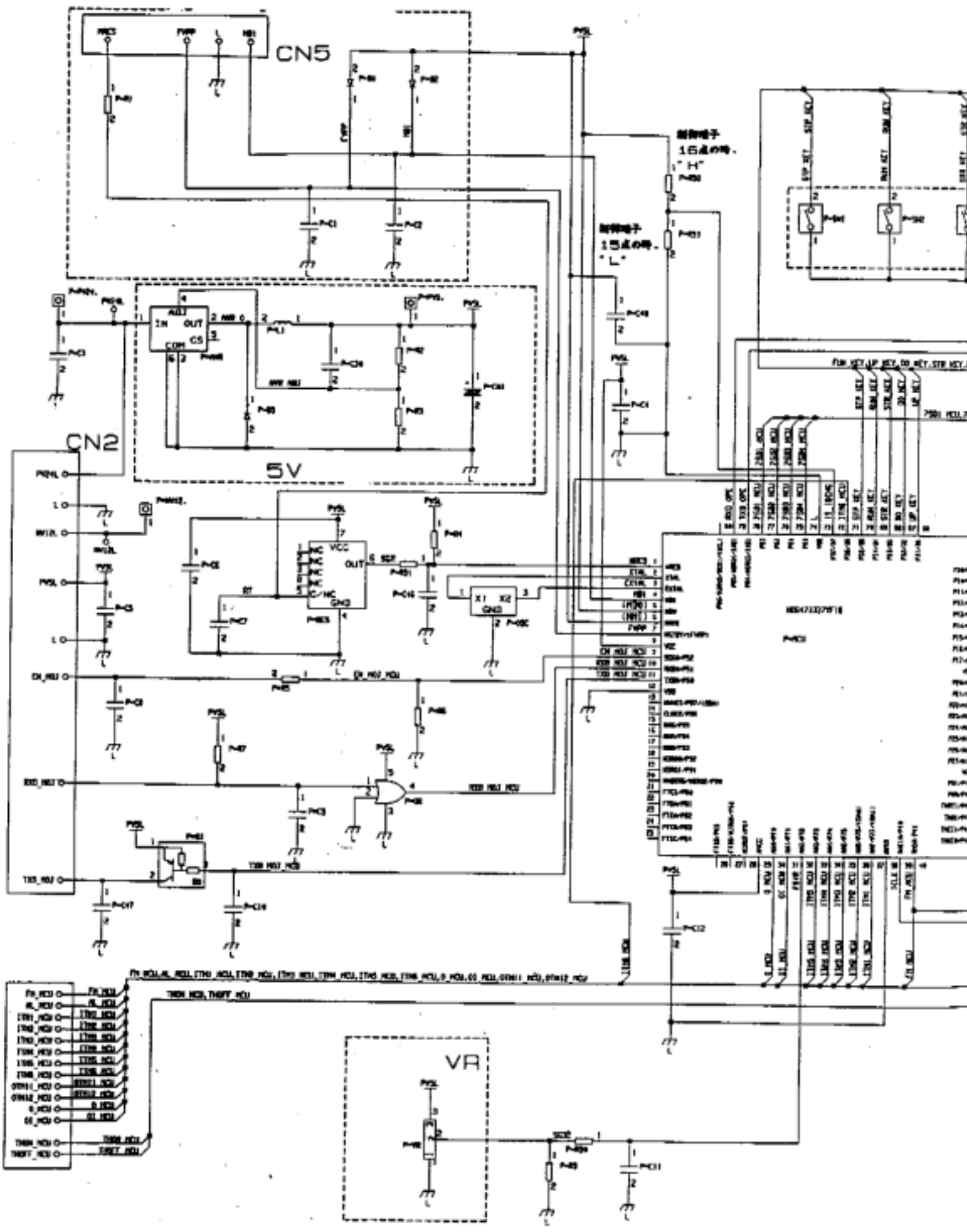

CN5

5V

CN2

VR

继电器
1点灯の時

继电器
1点灯の時

继电器
1点灯の時

继电器
1点灯の時

继电器
1点灯の時

继电器
1点灯の時

继电器
1点灯の時

继电器
1点灯の時

继电器
1点灯の時

继电器
1点灯の時

继电器
1点灯の時

继电器
1点灯の時

继电器
1点灯の時

继电器
1点灯の時

继电器
1点灯の時

继电器
1点灯の時

继电器
1点灯の時

继电器
1点灯の時

继电器
1点灯の時

- PL_REL O PL_REL
- RL_REL O RL_REL
- TR1_REL O TR1_REL
- TR2_REL O TR2_REL
- TR3_REL O TR3_REL
- TR4_REL O TR4_REL
- TR5_REL O TR5_REL
- TR6_REL O TR6_REL
- TR7_REL O TR7_REL
- TR8_REL O TR8_REL
- TR9_REL O TR9_REL
- TR10_REL O TR10_REL
- TR11_REL O TR11_REL
- TR12_REL O TR12_REL
- TR13_REL O TR13_REL
- TR14_REL O TR14_REL
- TR15_REL O TR15_REL
- TR16_REL O TR16_REL
- TR17_REL O TR17_REL
- TR18_REL O TR18_REL
- TR19_REL O TR19_REL
- TR20_REL O TR20_REL
- TR21_REL O TR21_REL
- TR22_REL O TR22_REL
- TR23_REL O TR23_REL
- TR24_REL O TR24_REL
- TR25_REL O TR25_REL
- TR26_REL O TR26_REL
- TR27_REL O TR27_REL
- TR28_REL O TR28_REL
- TR29_REL O TR29_REL
- TR30_REL O TR30_REL
- TR31_REL O TR31_REL
- TR32_REL O TR32_REL
- TR33_REL O TR33_REL
- TR34_REL O TR34_REL
- TR35_REL O TR35_REL
- TR36_REL O TR36_REL
- TR37_REL O TR37_REL
- TR38_REL O TR38_REL
- TR39_REL O TR39_REL
- TR40_REL O TR40_REL
- TR41_REL O TR41_REL
- TR42_REL O TR42_REL
- TR43_REL O TR43_REL
- TR44_REL O TR44_REL
- TR45_REL O TR45_REL
- TR46_REL O TR46_REL
- TR47_REL O TR47_REL
- TR48_REL O TR48_REL
- TR49_REL O TR49_REL
- TR50_REL O TR50_REL
- TR51_REL O TR51_REL
- TR52_REL O TR52_REL
- TR53_REL O TR53_REL
- TR54_REL O TR54_REL
- TR55_REL O TR55_REL
- TR56_REL O TR56_REL
- TR57_REL O TR57_REL
- TR58_REL O TR58_REL
- TR59_REL O TR59_REL
- TR60_REL O TR60_REL
- TR61_REL O TR61_REL
- TR62_REL O TR62_REL
- TR63_REL O TR63_REL
- TR64_REL O TR64_REL
- TR65_REL O TR65_REL
- TR66_REL O TR66_REL
- TR67_REL O TR67_REL
- TR68_REL O TR68_REL
- TR69_REL O TR69_REL
- TR70_REL O TR70_REL
- TR71_REL O TR71_REL
- TR72_REL O TR72_REL
- TR73_REL O TR73_REL
- TR74_REL O TR74_REL
- TR75_REL O TR75_REL
- TR76_REL O TR76_REL
- TR77_REL O TR77_REL
- TR78_REL O TR78_REL
- TR79_REL O TR79_REL
- TR80_REL O TR80_REL
- TR81_REL O TR81_REL
- TR82_REL O TR82_REL
- TR83_REL O TR83_REL
- TR84_REL O TR84_REL
- TR85_REL O TR85_REL
- TR86_REL O TR86_REL
- TR87_REL O TR87_REL
- TR88_REL O TR88_REL
- TR89_REL O TR89_REL
- TR90_REL O TR90_REL
- TR91_REL O TR91_REL
- TR92_REL O TR92_REL
- TR93_REL O TR93_REL
- TR94_REL O TR94_REL
- TR95_REL O TR95_REL
- TR96_REL O TR96_REL
- TR97_REL O TR97_REL
- TR98_REL O TR98_REL
- TR99_REL O TR99_REL
- TR100_REL O TR100_REL



5

6

7

8

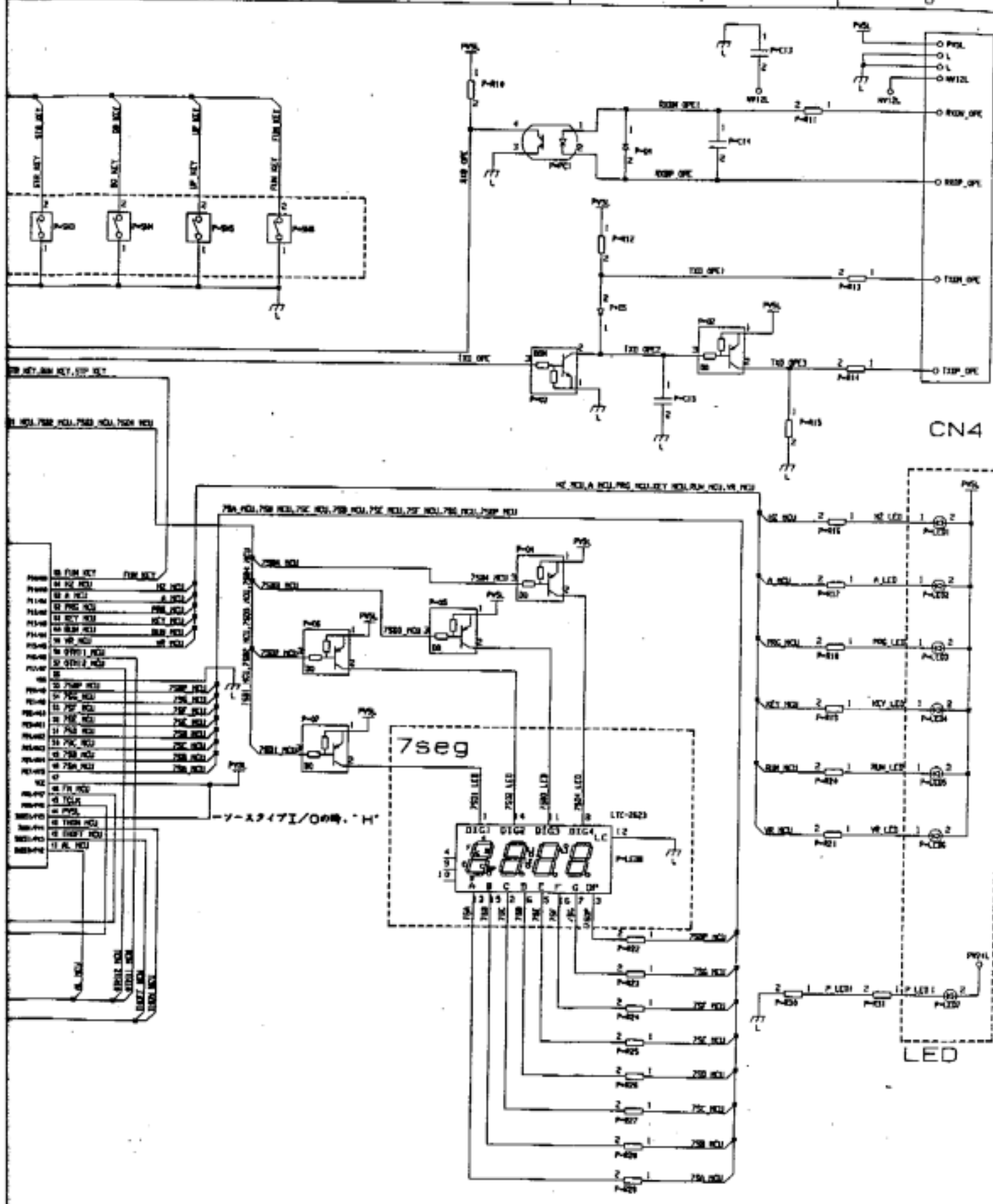

SJ100 series I/O board (source type)

324
 5T000115 1/3

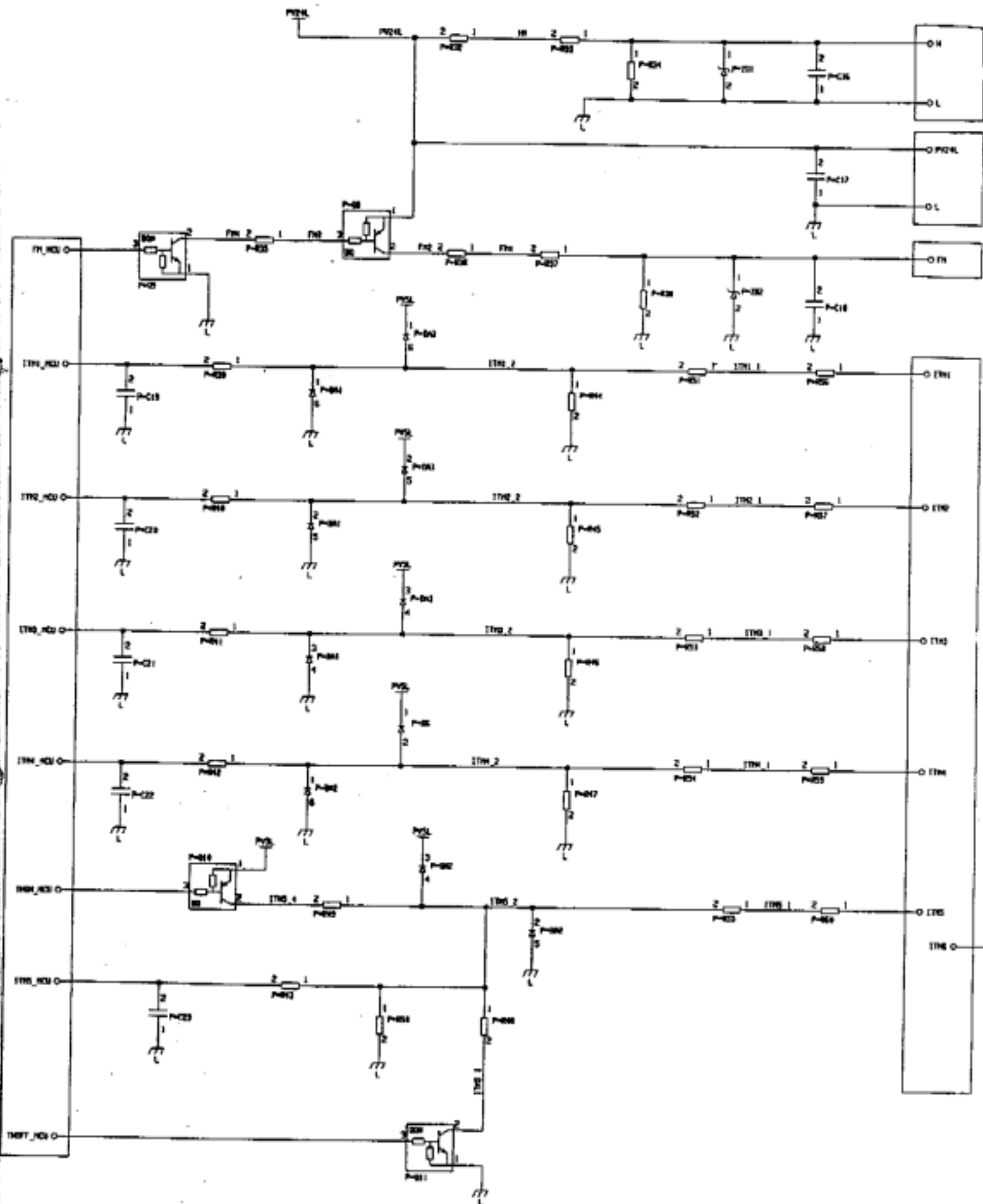

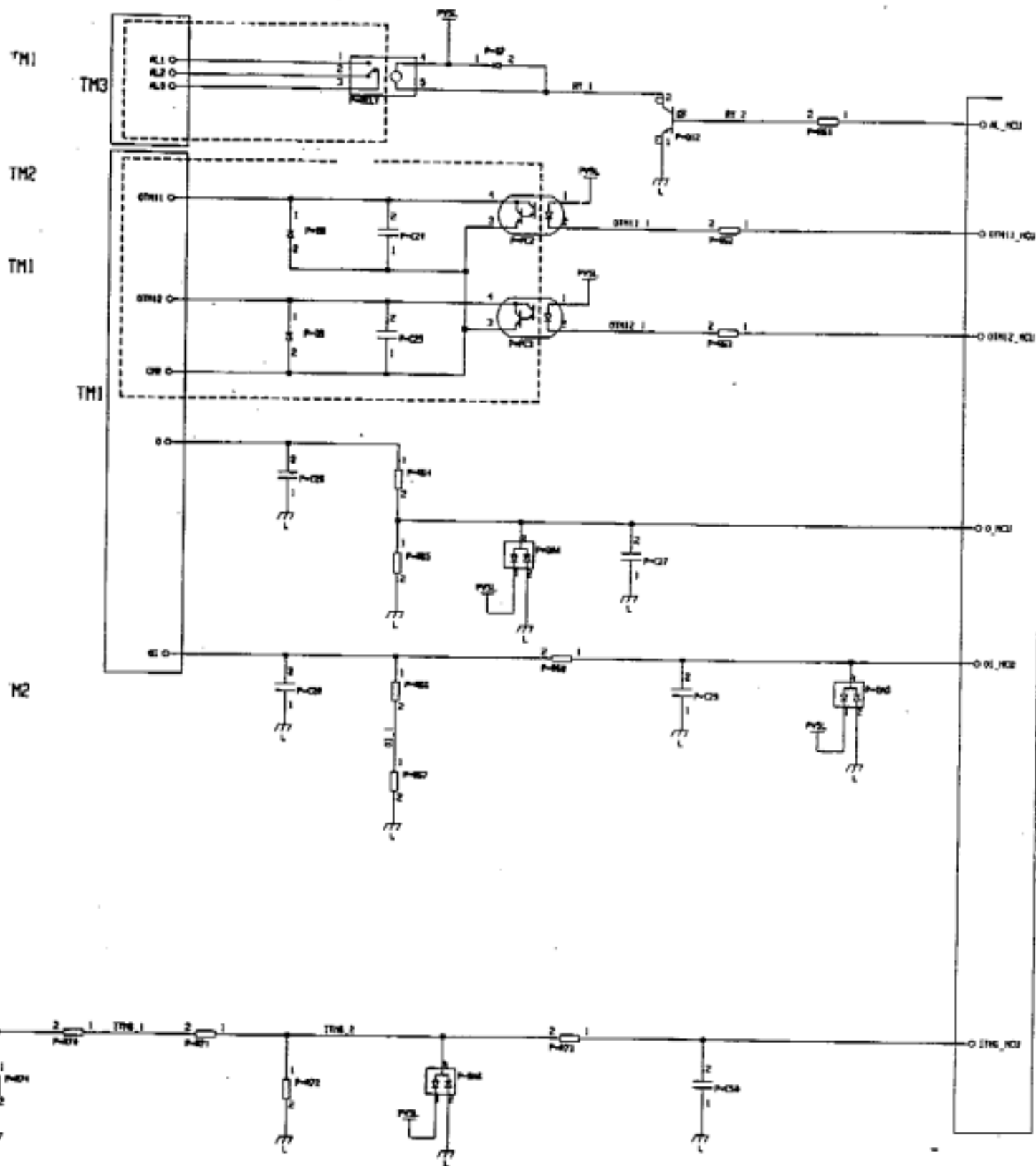

SJ100 series I/O board (source type)

(TM1)

P=TM1

PIN	WIRE	WIRE
1	H	
2	G	
3	DI	
4	L	
5	DI	
6	DI	
7	DI	112
8	DI	111

(TM2A)

P=TM2A

PIN	WIRE	WIRE
1	THB	112
2	THB	111
3	THB	112
4	THB	111
5	THB	112
6	THB	111
7	THB	111

(TM2B)

P=TM2B

PIN	WIRE	WIRE
1	L	
2	THB	111
3	THB	112
4	THB	111
5	THB	112
6	THB	111
7	THB	111
8	THB	111

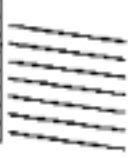

(TM3)

P=TM3

PIN	WIRE	WIRE
1	ALB	
2	ALB	
3	ALB	

(CN7)

P=CN7

PIN	WIRE	WIRE
1	THB	112
2	THB	111
3	THB	112
4	THB	111
5	THB	112
6	THB	111
7	THB	112
8	THB	111
9	THB	112
10	THB	111
11	THB	112
12	THB	111
13	THB	112
14	THB	111
15	THB	112
16	THB	111
17	THB	112

(CN4)

P=CN4

PIN	WIRE	WIRE
1	THB	112
2	THB	111
3	THB	112
4	THB	111
5	THB	112
6	THB	111
7	THB	112
8	THB	111
9	THB	112
10	THB	111
11	THB	112
12	THB	111
13	THB	112
14	THB	111
15	THB	112
16	THB	111
17	THB	112

(CN2)

P=CN2

PIN	WIRE	WIRE
1	THB	112
2	THB	111
3	THB	112
4	THB	111
5	THB	112
6	THB	111
7	THB	112
8	THB	111
9	THB	112
10	THB	111
11	THB	112
12	THB	111
13	THB	112
14	THB	111
15	THB	112
16	THB	111
17	THB	112

(CN5)

P=CN5

PIN	WIRE	WIRE
1	THB	112
2	THB	111
3	THB	112
4	THB	111



5

6

7

8

A

B

C

D

E

F

SJ100 series I/O board (source type)

Rev. 01	3/3
324	3
5T000115	3

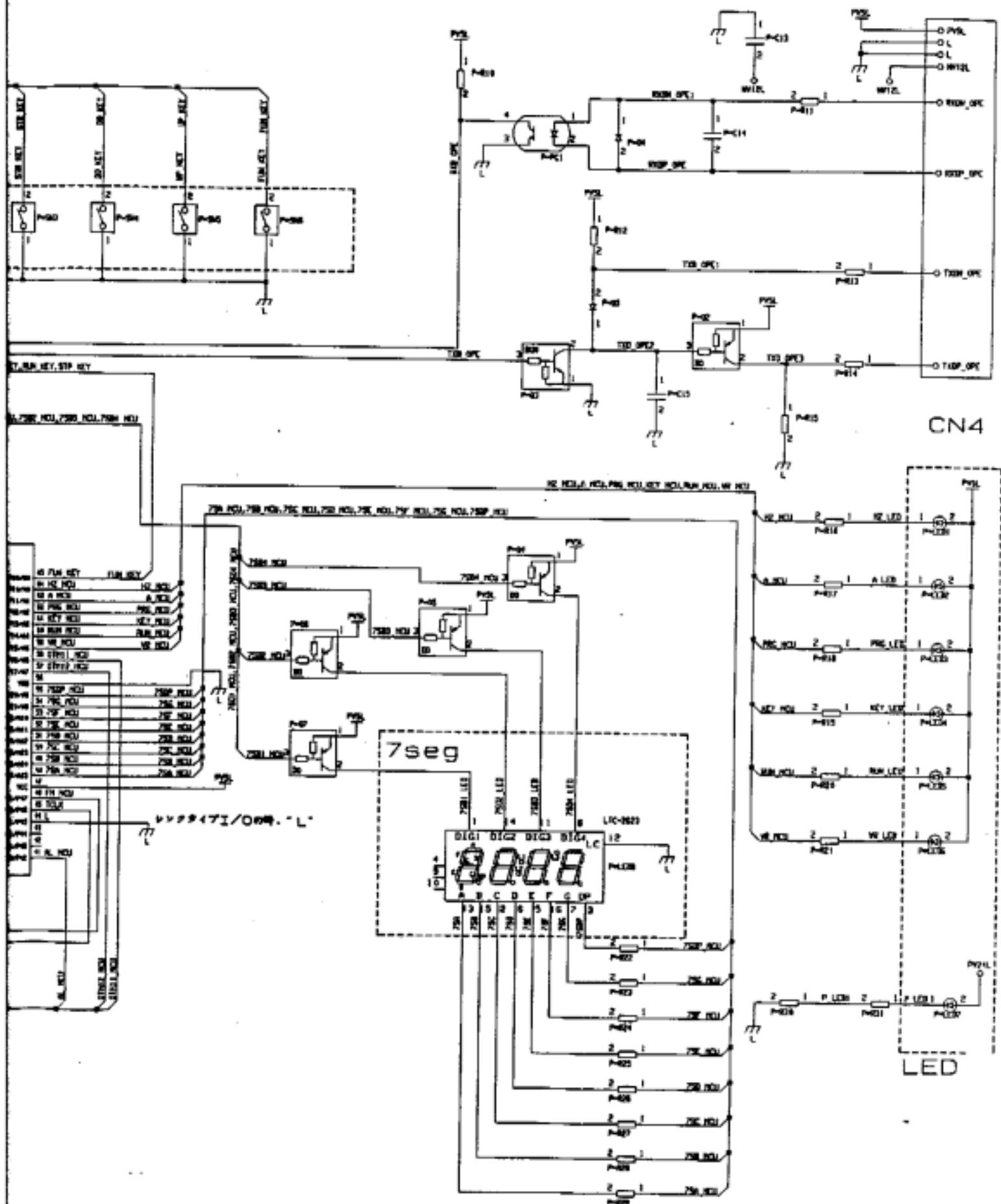

SJ100 series I/O board (sink type)

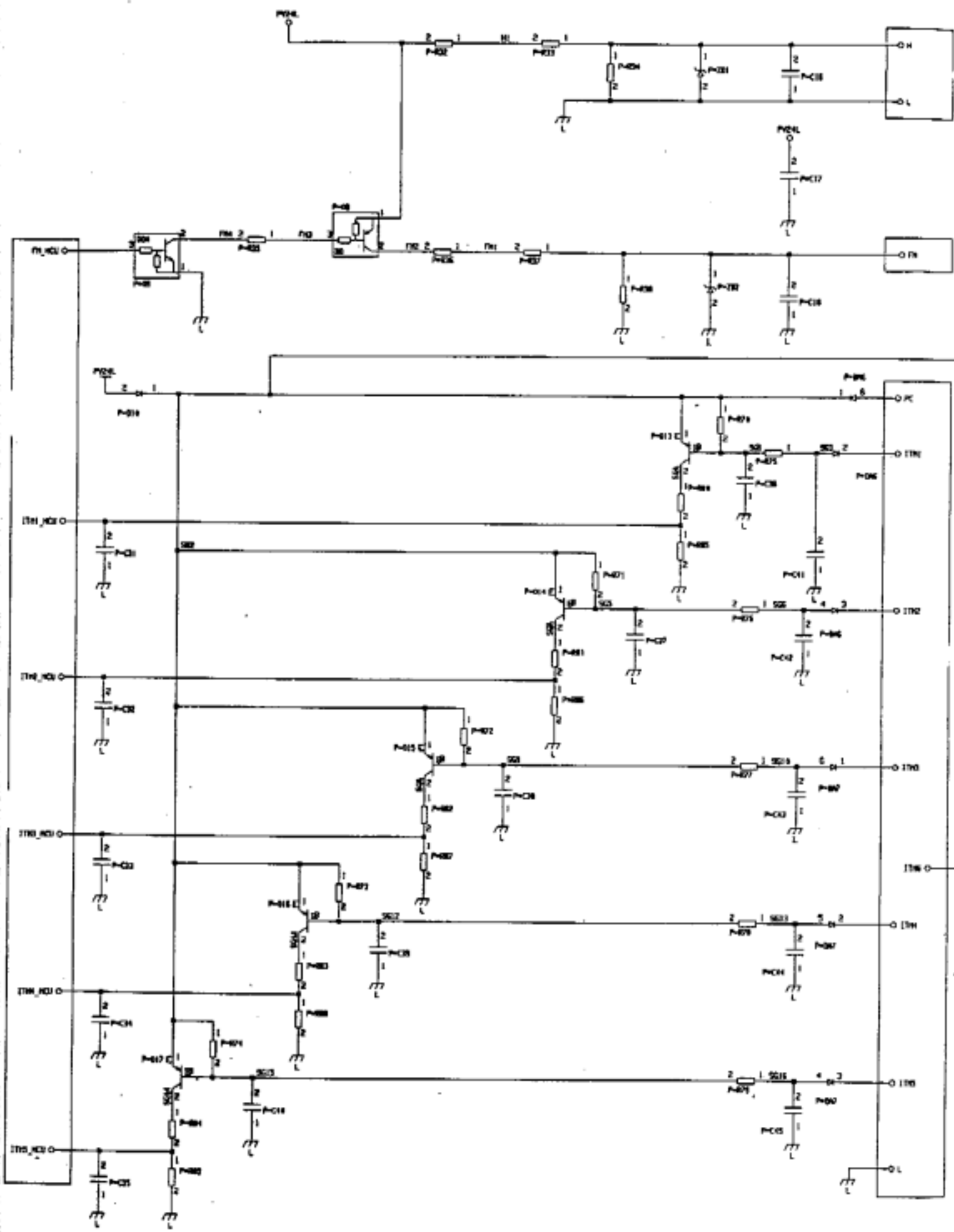

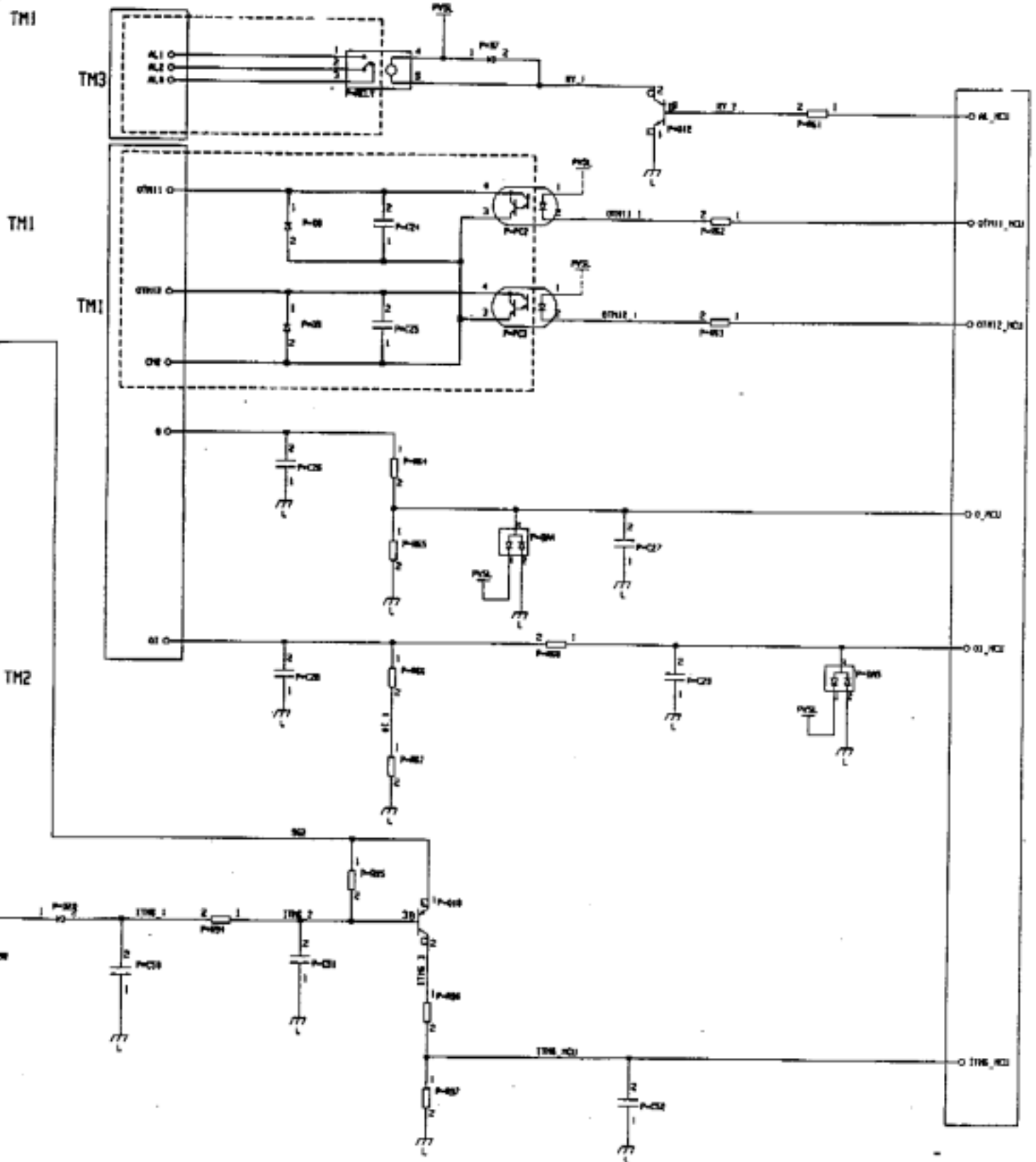

SJ100 series I/O board (sink type)

A

B

C

D

(TM1)

Pin	WIRE NAME
1	R
2	S
3	Q1
4	L
5	FR
6	GN
7	GN1 (112)
8	GN1 (113)

(TM2A)

Pin	WIRE NAME	VAL
1	TRM	(L)
2	TRM	(S)
3	TRM	(M)
4	TRM	(H)
5	TRM	(D)
6	TRM	(I)
7	PC	

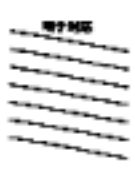

(TM2B)

Pin	WIRE NAME
1	L
2	TRM (S)
3	TRM (M)
4	TRM (H)
5	TRM (D)
6	TRM (I)
7	TRM (L)
8	PC

(TM3)

Pin	WIRE NAME
1	RL1
2	RL2
3	RL3

(CN7)

Pin	WIRE NAME
1	GN1 (113)
2	GN2 (112)
3	GN
4	PC
5	CH
6	TRM (L)
7	TRM (S)
8	TRM (M)
9	TRM (H)
10	TRM (D)
11	TRM (I) or R.C.
12	L
13	Q1
14	Q
15	R
16	
17	

(CN4)

Pin	WIRE NAME
1	PC
2	TRM (S)
3	TRM (M)
4	L
5	TRM (H)
6	TRM (D)
7	L
8	WFL
9	
10	

(CN2)

Pin	WIRE NAME
1	PC
2	TRM (M)
3	L
4	TRM (H)
5	TRM (D)
6	L
7	WFL
8	PC
9	
10	

(CN5)

Pin	WIRE NAME
1	L
2	GN1
3	GN2
4	TRM



5

6

7

8

A

B

C

D



E

F

SJ100 series I/O board (sink type)

富士通工業株式会社	Rev. 01	仕様
324		3
5T000116		3

End of page