

# HUBBELL P. R. CENTRIFUGAL SWITCH

Instruction Sheet

2200

February, 1974

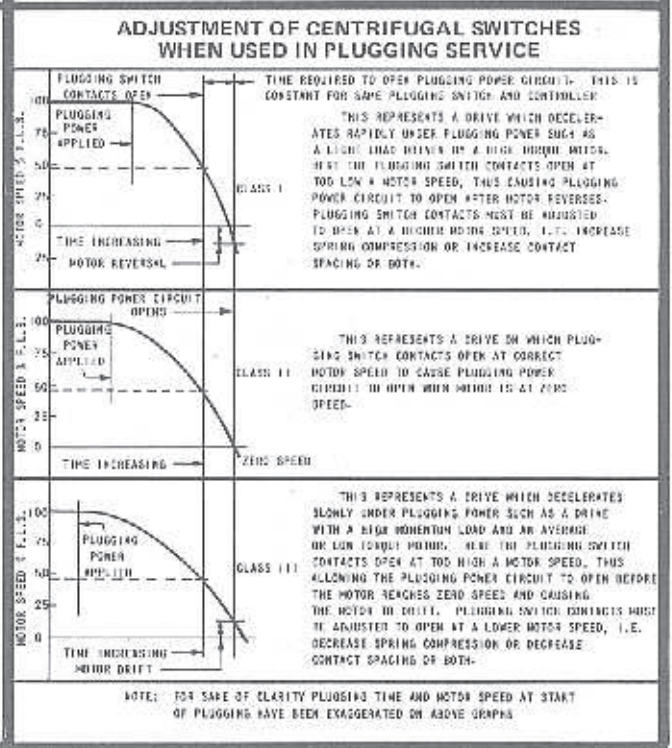
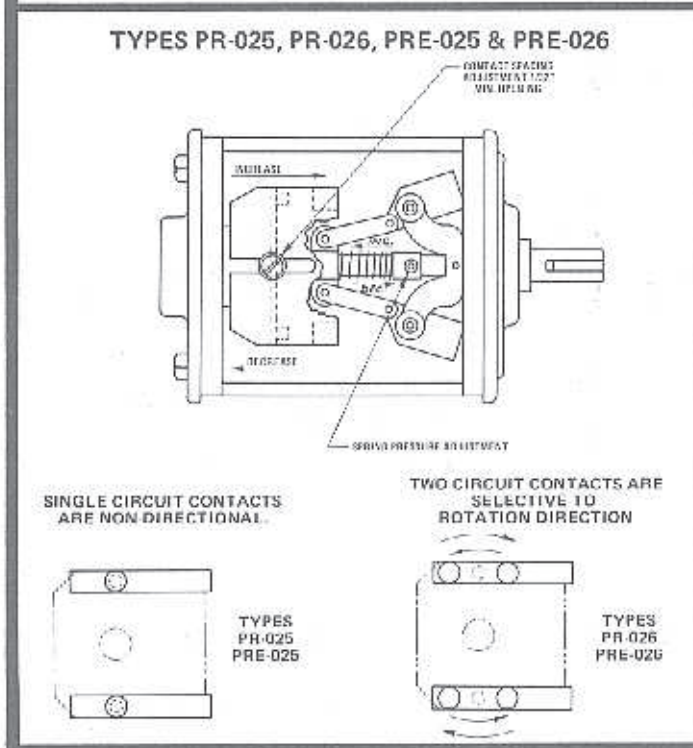
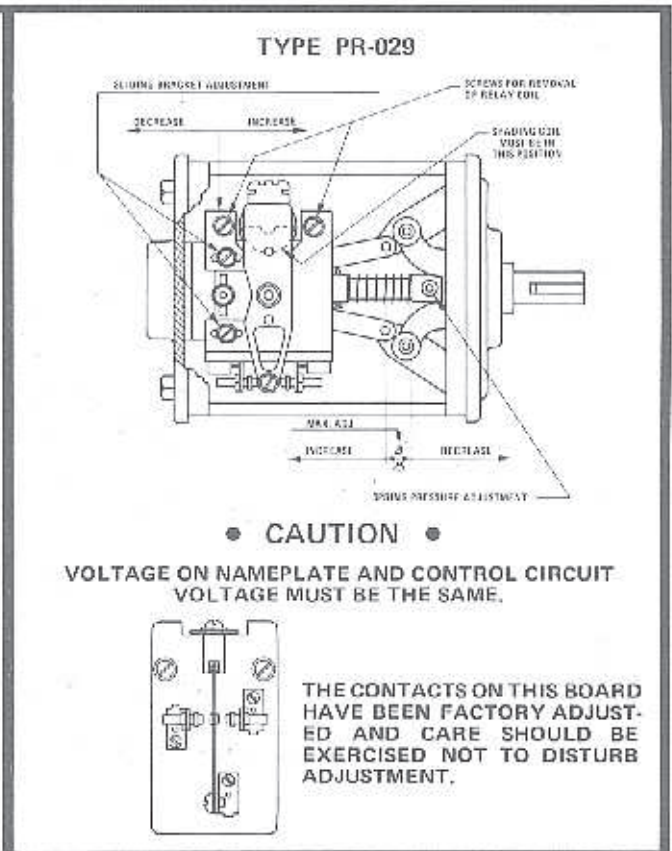
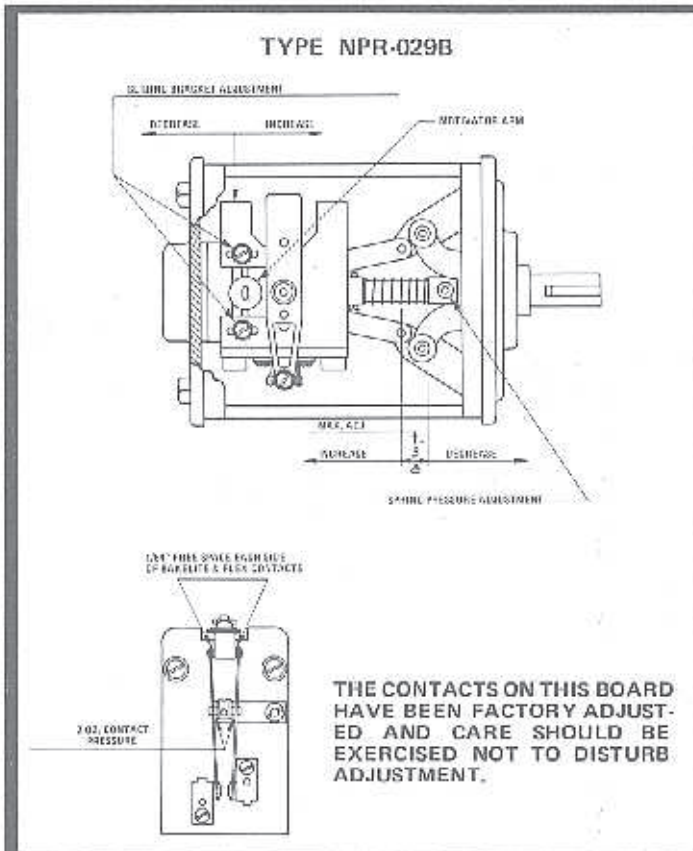

industrial controls division

Printed in U.S.A.

TYPES PRD-025 & PRS-025

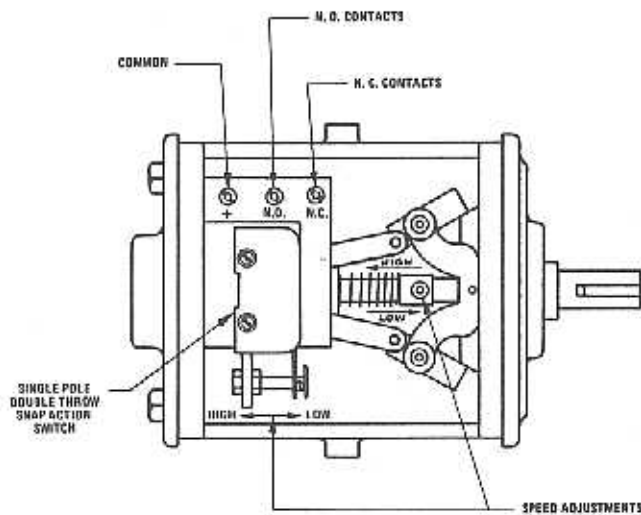

TYPES PRD-031 & PRS-031

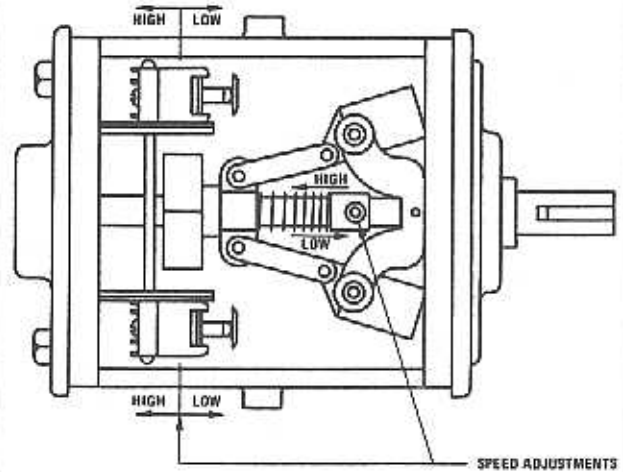

TYPES PRD-031B & PRS-031B

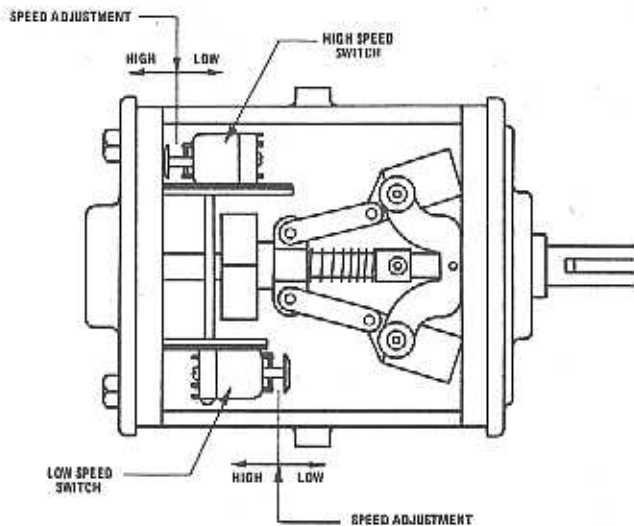

TYPE PRS-038M

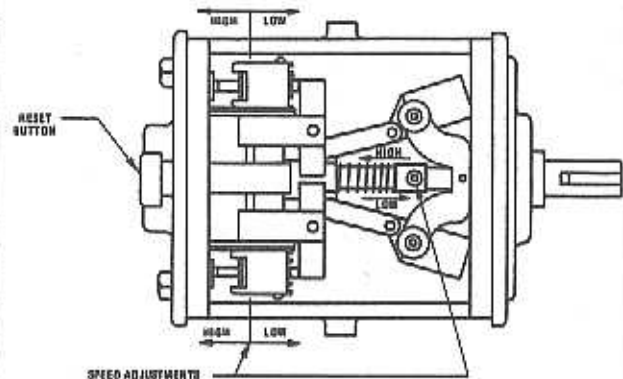

## INSTALLATION

HUBBELL switches should be properly aligned and mounted on a smooth flat surface by means of mounting bolts through the mounting holes provided in the mounting holes in the flange to permit proper alignment. If extreme vibration conditions exist, doweling of the switch mounting is recommended. When direct connecting these switches to a

mating shaft, a suitable resilient separator type coupling must be used.

## MAINTENANCE INSTRUCTIONS

Lubricate flyweight assembly with light oil, holes provided. Keep shaft clean and free from gum where sleeve bearings slide. All ball bearings are sealed and are permanently lubricated.