



For replacement parts information or an application guide, visit our website at www.hubbell-icd.com or contact your local Hubbell sales office.

Replacement Parts

58-GA14

November 2003

Reversing OFF ON
Two Speed Special Purpose
Class 58
A14, A15

IMPORTANT
THESE INSTRUCTIONS DO NOT PURPORT TO COVER ALL DETAILS OR VARIATIONS IN EQUIPMENT NOR TO PROVIDE FOR EVERY POSSIBLE CONTINGENCY TO BE MET IN CONNECTION WITH INSTALLATION, OPERATION OR MAINTENANCE. SHOULD FURTHER INFORMATION BE DESIRED OR SHOULD PARTICULAR PROBLEMS ARISE WHICH ARE NOT COVERED SUFFICIENTLY FOR THE PURCHASER'S PURPOSES, THE MATTER SHOULD BE REFERRED TO THE LOCAL HUBBELL SALES OFFICE.

WARNING
Hazardous voltage.
Can cause death or serious injury.
Disconnect main power and control voltages before installation or maintenance on this equipment.

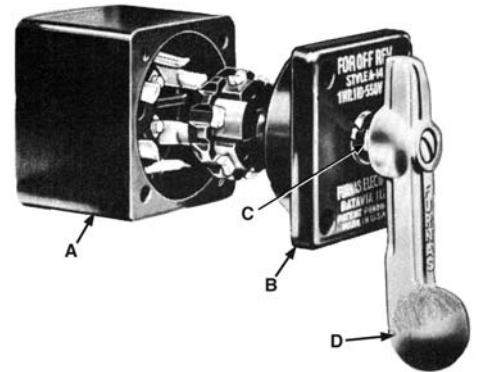
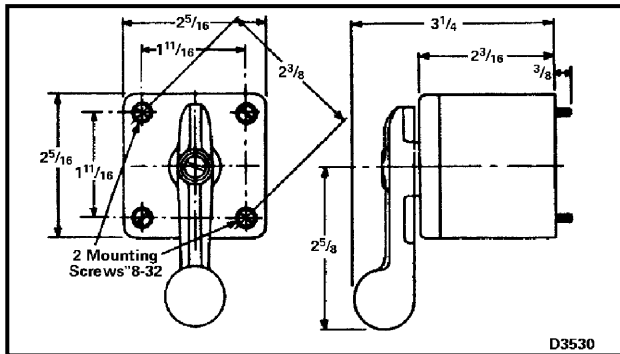

A14 (Interchanging Leads To 2 And 4 Reverses Motor Rotation)			
Direct Current 1/4 HP 115-230V	AC Single and Three Phase 1 HP 110-550V		
D.C. Shunt 	Condenser Motor 4 Leads 	Three Phase 	Repulsion Induction Motor, 4 Leads, Series Winding Reversing Type Only
D.C. Series 	Condenser Motor 6 Leads 120V 	Split Phase 	Repulsion-Induction Three Motor Leads
D.C. Compound 	Condenser Motor 6 Leads 240V 	OFF - ON DPST 	Internal Connections Bottom View

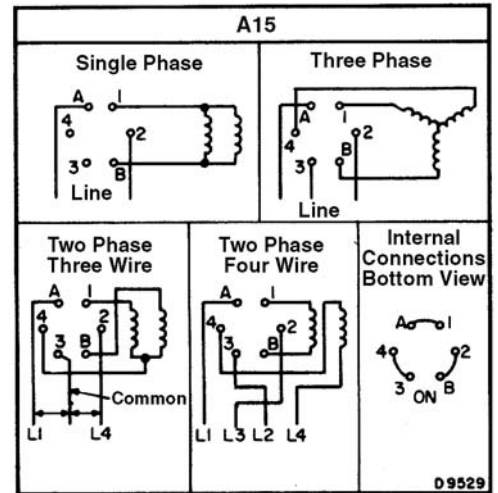

Item	Part Name	Part number
A	Molded Base Assembly Complete with (6) Fingers (Qty. 1)	D09593001
B	Top (A14) (Qty. 1) Top (A15) (Qty. 1)	D03519001 D30519002
C	Spindle (Qty. 1)	D27655001
D	Radial Handle (Standard) (Qty. 1) Safety Handle (Optional, not shown) (Qty. 1)	D55 711001 D10018001

NOTE: When ordering replacement parts, give catalog number of control and part name and number.

(For Engineering Reference Only - Rev. C)