

Outline Drawings

Special Purpose – Type 720

Type 720, Contactor with Standard Capacity Arc Chute, Insulated Sheet and Base Mounted

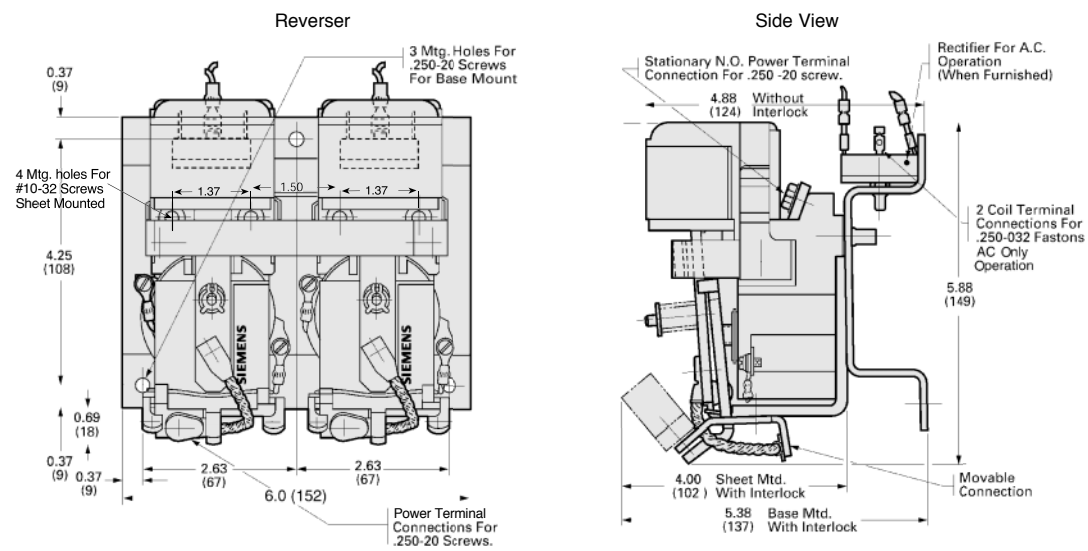
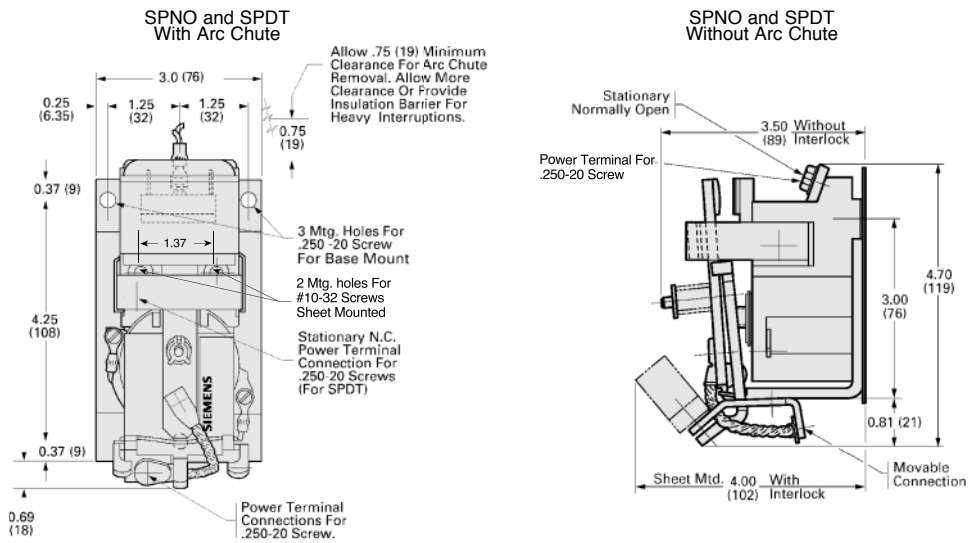

Type 720, Contactor with High Capacity Arc Chute, Insulated Sheet and Base Mounted

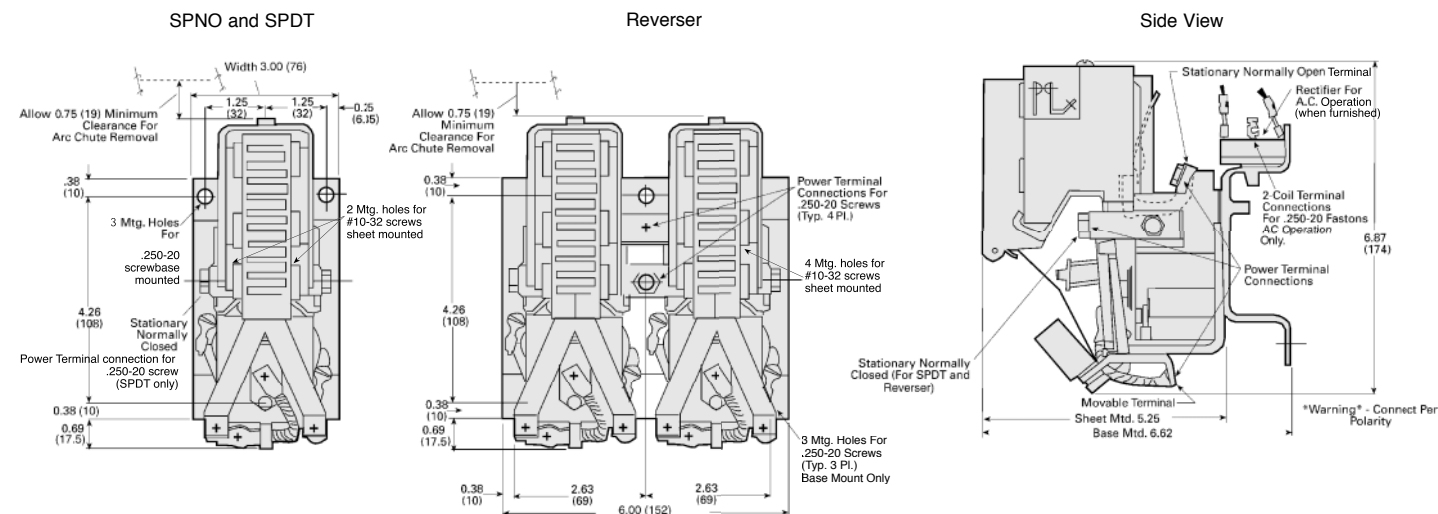

All dimensions shown in inches. For reference purposes only. Not to be used for design or construction purposes.

Spec Tech Industrial 203 Vest Ave. Valley Park, MO 63088 Phone: 888 SPECTECH
Email: sales@spectechind.com www.spectechind.com

Hubbell Industrial Controls, Inc.

Type 720 200 Ampere 600 Volt DC Contactor

Catalog 42720 • September 2005

42720

Application/Model List

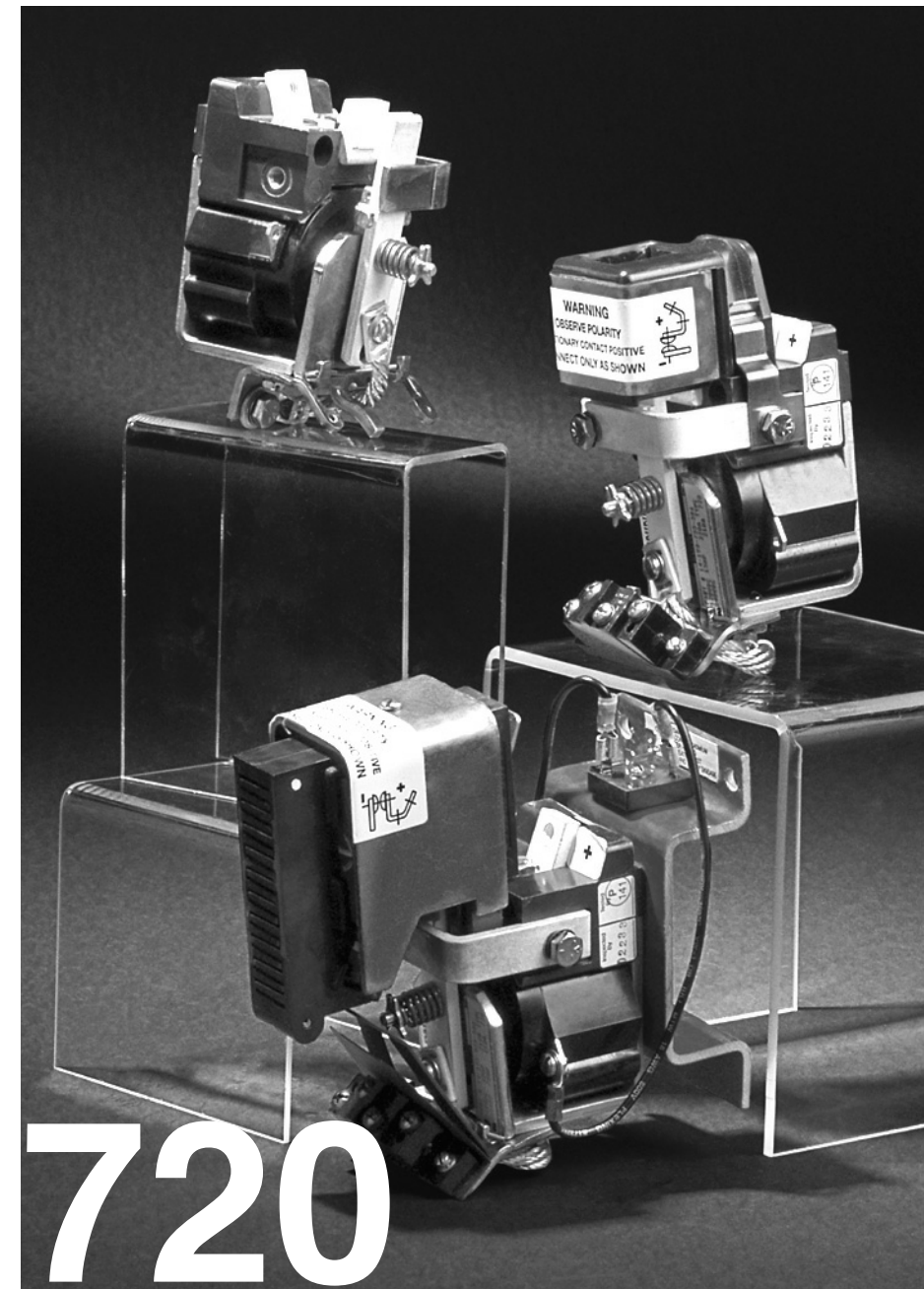

Highlights

- NEMA Size 4 1/2
- UL recognized/CSA certified
- Polarized arc chutes – standard capacity or high capacity
- Main contact options: SPNO, SPDT, Series Field Reverser
- Five million mechanical operations
- Silver alloy main contacts
- Front access for serviceability
- AC or DC operation
- High dielectric and mechanical strength
- Special ratings available – Consult factory

Rugged and reliable, this industrial quality device is used in applications such as gas/oil drilling and solid-state adjustable speed drives, uninterruptible power supplies, fuel cells, crane controls, transit and rail, and mining machinery. It is rated at 200 Ampere, continuous at 600 VDC in still air (special voltages available – consult factory) and can achieve a maximum interrupting rating of 600 kW.

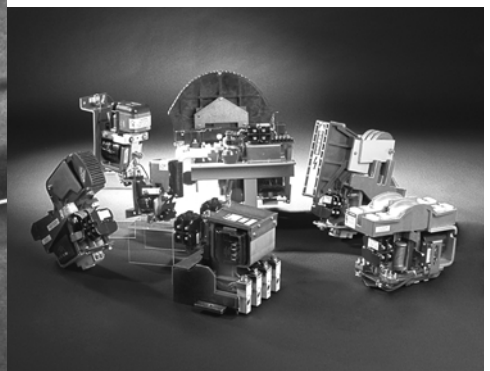

720 DC CONTACTOR

Amazingly Reliable – Hubbell Industrial Controls Devices

The Hubbell ICD family of rugged, high-performance DC devices are in great demand by industries needing reliable, solid state, adjustable controls. Products include contactors, limit switches, crane controls, fire pump controls, transfer switches, motor controllers and resistors. Hubbell ICD has a device ideal for a wide range of applications. And if it's from Hubbell, you know you're getting amazingly reliable technology.



hubbell industrial controls, inc.

Spec Tech Industrial 203 Vest Ave. Valley Park, MO 63088 Phone: 888 SPECTECH
Email: sales@spectechind.com www.spectechind.com

Both UL recognized as a general-purpose NEMA Size 4.5 contactor and UL recognized and CSA certified as a definite purpose contactor for solid-state adjustable speed drives.

Available with SPNO, SPDT, or Series Field Reverser main pole configurations, the Type 720 contactor can be ordered with or without permanent magnet arc chutes. The Type 720 with arc chute is polarized for arc interruption; therefore, external power connections must observe proper polarity, as marked on the power connection terminals, to provide appropriate arc interruption.

When used, the permanent-magnet-type arc chute provides full interrupting capability on the normally open contacts only. When using contactors with normally closed power poles (SPDT and reverser), the application should be reviewed to ensure that the make-and-break capabilities of the normally closed contacts are not exceeded.

Available in ratings from 12 VDC to 250 VDC, the molded coils are Class F (155C) design and rated for continuous duty. Although screw terminals are standard, some coil ratings are available with leads by special order. AC coil operation is achieved by the addition of a full-wave bridge rectifier.

Pilot-duty auxiliary contact blocks are available in 1NO&1NC and 2NO&2NC configurations.

Vertical mounting is recommended for the Type 720 contactor (contact factory for non-vertical mounting considerations). Each device is provided with either an insulated mounting sheet (sheet mounted) or an insulated mounting base (base mounted) for mounting on conductive surfaces. The insulated mounting base provides a location for mounting a full-wave bridge rectifier for AC operation. All terminals and mounting holes are front-accessible for ease of mounting and wiring with hardware provided for these purposes. Front-accessible arc chutes can be easily removed/replaced without tools.

Generously sized silver alloy contact surfaces, inherent wiping action upon closure, silver-plated copper conductors, and high contact pressure assure reliable, robust service from this compact device in the most extreme and demanding environments. Non-conducting steel components are zinc-dichromate plated for corrosion resistance, while the molded components are fabricated from a non-tracking material offering high dielectric strength and protection for the coil from dirt, moisture, and physical abuse.

Product Listing

Special Purpose – Type 720 Series

Ordering Information

> Type 720 contactors are ordered by Catalogue Number as follows: Catalogue Number

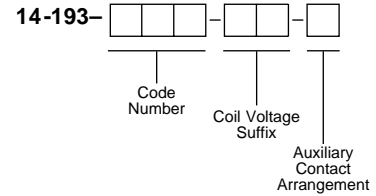

Coil Suffix Table^①

DC Volts Coil Voltage	Suffix
12	51
24	52
36	55
48	54
74	56
96	57
125	58
250	59

Specifications

Type 720, ⚡, Ⓢ 200 Amps only

Contact Configuration

- Single pole, normally open (SPNO)
- Single pole, double throw (SPDT)
- Series field reverser (2 SPDT bussed together)
- Special combinations are available
- Consult Factory

Voltage Rating

- 600 VDC standard
- Consult Factory for special ratings
- UL Recognition File: E79773
- CSA Certification File: LR91674

Mechanical Life

- 5 million operations

Connection

- Power terminals – One ¼–20 tapped hole per terminal
- Coil terminals – Two 8–32 tapped holes
- Full-wave bridge rectifier – Four ¼ in. fastons

Weights

- Contactor without Arc Chute 3.0 lbs. (1.36 kg)
- Contactor with Standard Capacity Arc Chute 3.7 lbs. (1.68 kg)
- Contactor with High Capacity Arc Chute (200 Amp) 4.7 lbs. (2.14 kg)
- Two Contactors with Standard Capacity Arc Chutes 8.2 lbs. (3.72 kg)
- Two Contactors with High Capacity Arc Chutes 10.2 lbs. (4.63 kg)

Mounting

- 1) Two 10–32 screws through contactor and insulation sheet
- 2) Three ¼–20 screws through mounting base

Mounting Hardware

- Two 10–32 screws (contactor)
- Three ¼–20 screws (base)

Main Contact Rating (200 Amps Version)

Description	Normally Open	Normally Closed
Continuous Carry Current Convection Cooled	220 Amps	200 Amps
Maximum Make Rating	2000, 600 V DC	200 Amps, 50 V DC 150 Amps, 150 V DC 100 Amps, 500 V DC
Max Break Rating*	Without Arc Chute	2000, 48 V DC
	With Standard Capacity Chute	300, 300 V DC
	With High Capacity Chute	1200, 125 V DC
	With High Capacity Chute	2000, 300 V DC
	1000, 600 V DC	200 Amps, 50 V DC 150 Amps, 150 V DC 100 Amps, 240 V DC 200 Amps, 50 V DC 125 Amps, 125 V DC

Arc chute is permanent magnet type. Polarities must be observed.

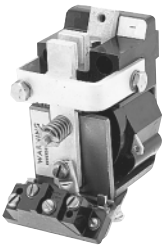
Illustration	Power Circuit DC Voltage	Arc Chute	Mounting	Coil Rectifier	Arc Chute Polarity ^②	SPNO Code	SPDT Code	Reverser ^{③④} Code
Type 720, 100 Ampere 	12-48	None	Sheet ^⑤	No	N/A	791	792	793
		Std. Capacity	Sheet ^⑤	No	Pos.	794	795	796
	50-300	Std. Capacity	Sheet ^⑤	No	Neg.	798	797	799
		Std. Capacity	Base	Yes ^f	Pos.	771	772	773
		Std. Capacity	Base	Yes ^f	Neg.	774	775	776

TYPE 720 WITHOUT ARC CHUTE

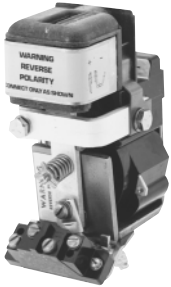
Type 720, 200 Ampere 	12-48	None	Sheet ^⑤	No	N/A	751	752	753
		Std. Capacity	Sheet ^⑤	No	Pos.	754	755	756
	50-300	Std. Capacity	Sheet ^⑤	No	Neg.	758	757	759
		Std. Capacity	Base	Yes ^⑥	Pos.	761	762	763
		Std. Capacity	Base	Yes ^⑥	Neg.	764	765	766
		High Capacity	Base	No	Pos.	821	822	823
		High Capacity	Base	No	Neg.	831	832	833
	100-600	High Capacity	Base	Yes ^⑥	Pos.	824	825	826
		High Capacity	Base	Yes ^⑥	Neg.	834	835	836
		High Capacity	Sheet ^⑤	No	Pos.	841	842	843
	High Capacity	Sheet ^⑤	No	Neg.	851	852	853	

TYPE 720 WITH STANDARD CAPACITY ARC CHUTE

Auxiliary Contacts^⑥

Configuration	Code
1 NO & 1 NC	6
2 NO & 2 NC	2
None	7

- ① For 120 volts, 60 Hz operation, use 125 volt DC coil with full-wave bridge rectifier.
- ② For maximum break rating of polarity sensitive arc chutes, connect indicated polarity to normally open stationary terminal.
- ③ For reversers, price two auxiliary contacts: (1) for forward, (1) for reverse.
- ④ Configured for series field reversal.
- ⑤ Insulated mounting sheet (1/32" thick) provided with contactor.
- ⑥ Coil voltage tolerance 85 to 110% of rated voltage.

Connection Diagrams

Operating Coils

Volts DC	Ohms (20°C)	Volts DC	Ohms (20°C)
12	2.6	74	93
24	10.4	96	148
36	25	125	226
48	41.1	250	960

Minimum pickup voltage is 55% of rated coil volts, with cold coil and 80% of rated coil volts with hot (140°) coil. Dropout is from 5% to 25% of rated coil volts. Coil overvoltage tolerance is 10%.

Auxiliary Contacts

Configuration	Continuous Current	Make and Break
1 NO and 1 NC	15 Amps**	15 Amps, 600 V AC, resistive 0.4 Amps, 115 V DC, inductive 0.2 Amps, 230 V DC, inductive
2 NO and 2 NC	10 Amps**	10 Amps, 600 V AC, resistive 0.2 Amps, 115 V DC, inductive 0.1 Amps, 230 V DC, inductive

* Resistive load – consult sales office for inductive load break ratings. For arc chute spacings to ground, consult sales office.

** Each normally open and normally closed pair must be wired to the same side of the same supply (same polarity).

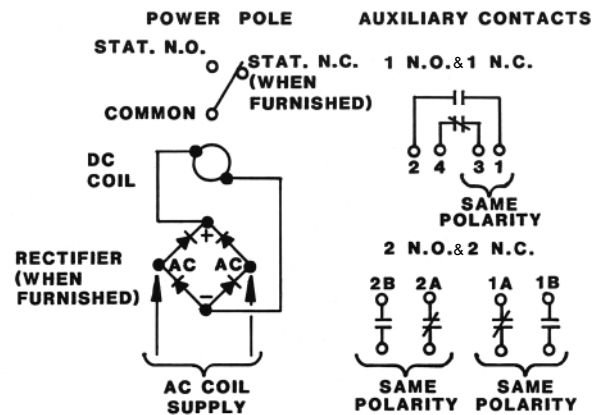

Outline Drawings

Special Purpose – Type 720

Type 720, Contactor
with Standard Capacity
Arc Chute, Insulated
Sheet and Base Mounted

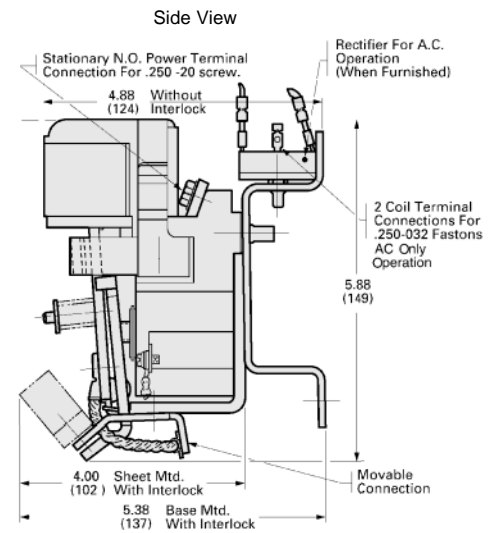
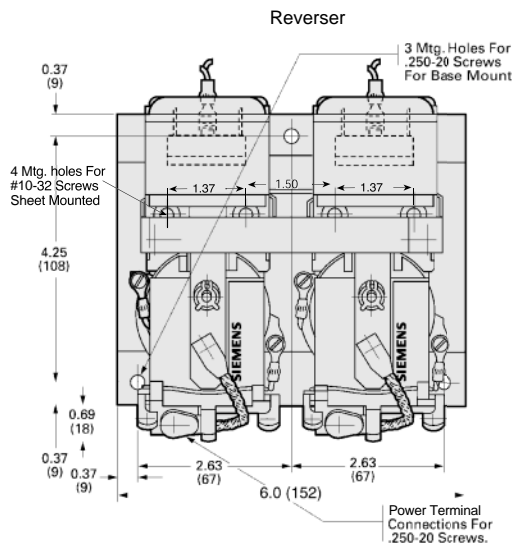
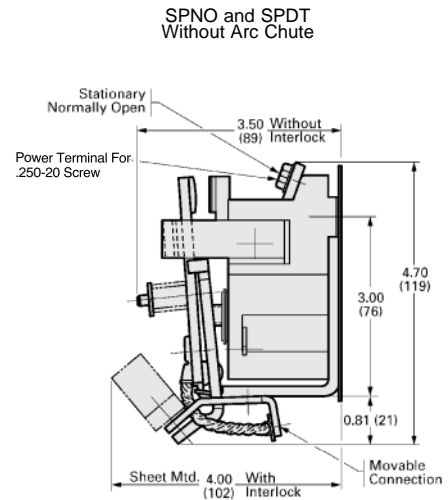
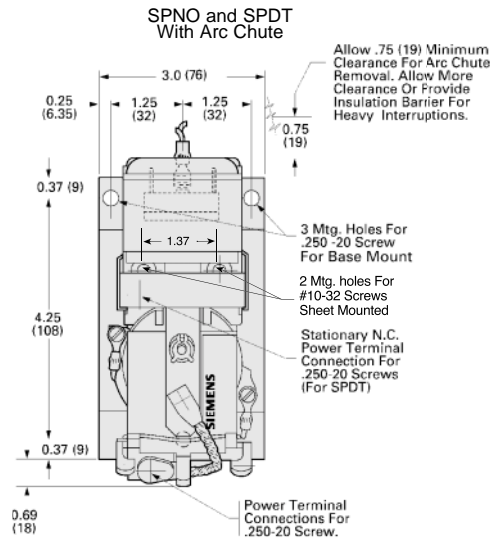

Type 720, Contactor with High Capacity Arc Chute, Insulated Sheet and Base Mounted

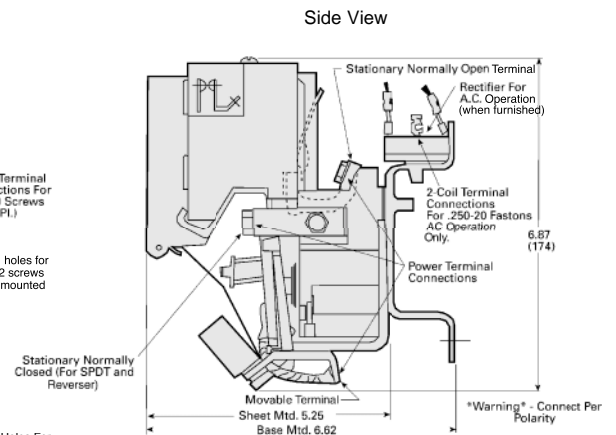
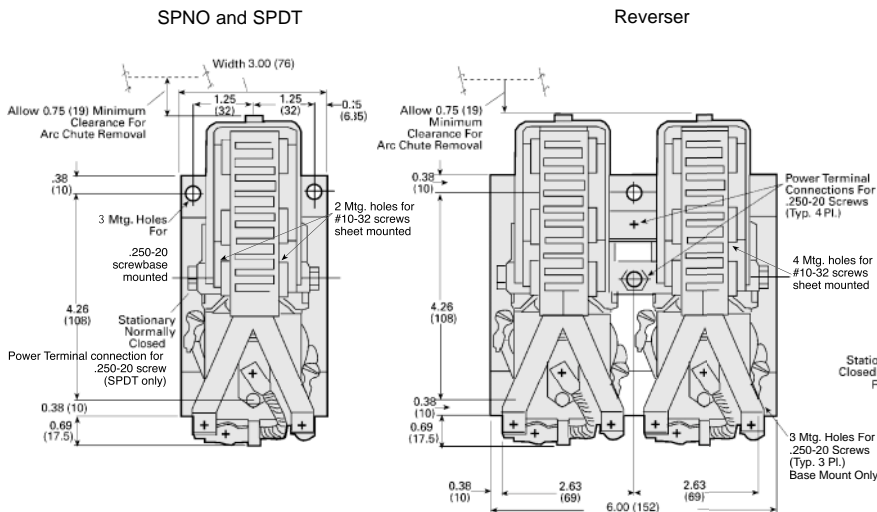

All dimensions shown in inches. For reference purposes only. Not to be used for design or construction purposes.



Hubbell Industrial Controls, Inc.
A subsidiary of Hubbell Incorporated
4301 Cheyenne Dr., Archdale, NC 27262
Telephone (336) 434-2800 • Fax (336) 434-2803
<http://www.hubbell-icd.com>
Sales@hubbell-icd.com