

BNH/BN Series



Key features of the BNH/BN series include:

- Touch-down terminals with spring-loaded captive screws
- Jumpers available up to 30A model
- Fuse block with or without blown-fuse indicator in neon or LED
- Mount on 35mm standard DIN rail



UL Recognized
File No. E78117



CSA Certified
File No. LR64803



File No. R9551701
J9551516 (power blocks)
R9650688 (dual-deck blocks)



Specifications

Part Numbers		BNH10W	BNH15MW	BNH15LW	BNH30W
Appearance					
Width		0.275" (7mm)	0.315" (8mm)	0.413" (10.5mm)	0.472" (12mm)
Approvals		UL, CSA, TUV	UL, CSA, TUV	UL, CSA, TUV	UL, CSA, TUV
No. of Poles		1	1	1	1
Wire Sizes		22 to 16 AWG	22 to 14 AWG	22 to 14 AWG	18 to 10 AWG
Voltage/Current		600V / 10A	600V / 10A	600V / 15A	600V / 30A
Terminals	Size	M3	M3	M3.5	M4
	Type	Touch-down	Touch-down	Touch-down	Touch-down
Mounting		35mm DIN rail	35mm DIN rail	35mm DIN rail	35mm DIN rail
Terminal Torque	(N-m)	0.6 - 1.0	0.6 - 1.0	1.0 - 1.3	1.4 - 2.0
	(in-lbs.)	5.3 - 8.9	5.3 - 8.9	8.9 - 11.5	12.4 - 17.8
End Plate		BNE15W	BNE15W	BNE15W	BNE30W
DIN Rail Stop		BNL-5	BNL-5	BNL-5	BNL-5
Dust Cover		BNC230	BNC230	BNC230	BNC230
Marking Strip	PVC	BNM7	BNM7	BNM7	BNM7
	Fiberglass	BNM9	BNM9	BNM9	BNM9
	End clip	BNM3	BNM3	BNM3	BNM3
Ring Terminal Jumpers		BNJ 16	BNJ26W	BNJ46	BNJ56
Fork Terminal Jumpers		BNJ 16F	BNJ 26FW	BNJ 46F	BNJ 56F

1. BNDN1000 aluminum DIN rails are available in 1 meter lengths.
2. Marking strips are available in 1 meter lengths.
3. Jumpers are available in groups of six.
4. Remove the "H" in the terminal block part number for standard screw type (ex. BNH10W becomes BN10W).

Switches & Pilot Lights

Display Lights



Relays & Sockets

Timers

Terminal Blocks

Circuit Breakers

Specifications, continued

Part Numbers		BNH50W	BN75W	BN150W	BNDH15W
Appearance					
	Width	0.610" (15.5mm)	0.787" (20mm)	1.024" (26mm)	0.315" (8mm)
Approvals		UL, CSA, TUV	UL, CSA, TUV	UL, CSA, TUV	UL, CSA, TUV
No. of Poles		1	1	1	2
Wire Sizes		16 to 6 AWG	16 to 4 AWG	16 to 0 AWG	22 to 14 AWG
Voltage/Current		600V / 50A	600V / 75A	600V / 150A	600V / 10A
Terminals	Size	M5	M6	M8	M3
	Type	Touch-down	Hex bolt	Hex bolt	Touch-down
Mounting		35mm DIN rail	35mm DIN rail	35mm DIN rail	35mm DIN rail, surface
Terminal Torque	(N-m)	2.6 - 3.7	3.9 - 5.4	10 - 13.5	0.6 - 1.0
	(in.-lbs.)	23.1 - 32.8	34.6 - 47.9	88.8 - 119.8	5.3 - 8.9
End Plate		BNE50W	BNE75W	BNE150W	BNDE15W
DIN Rail Stop		BNL-5	BNL-6	BNL-6	BNL-8
Dust Cover		BNC320	BNC420	BNC520	BNC230 (top level) BNC240 (bottom Level)
Marking Strip	PVC	BNM7	BNM7	BNM7	BNM7
	Fiberglass	BNM9	BNM9	BNM9	BNM9
	End clip	BNM3	BNM3	BNM3	BNM3
Connecting Rods		—	—	—	BNR1 10.34" (265mm) BNR2 19.69" (500mm)
Connecting Nuts		—	—	—	BNN1 (2 pieces)
Base Mount Brackets		—	—	—	BNDL2
Ring Terminal Jumpers		—	—	—	BNJ26
Fork Terminal Jumpers		—	—	—	BNJ26FW



1. BNDN1000 aluminum DIN rails are available in 1 meter lengths.
2. Marking strips are available in 1 meter lengths.
3. Jumpers are available in groups of six.
4. Remove the "H" in the terminal block part number for standard screw type (ex. BNH50W becomes BN50W).

Switches & Pilot Lights

Display Lights



Relays & Sockets

Timers

Terminal Blocks

Circuit Breakers

Specifications, continued

Part Numbers		BNF10SW	BNF10NW	BNF10DW
Appearance				
	Width	0.591" (15mm)	0.591" (15mm)	0.591" (15mm)
	Blown Fuse Indicator	None	Neon (100–300VAC)	LED (24V DC)
	Approvals	UL, CSA	UL, CSA	UL, CSA
No. of Poles	1	1	1	
Wire Sizes	18 to 10 AWG	18 to 10 AWG	18 to 10 AWG	
Voltage/Current	600V/10A maximum	600V/10A maximum	600V/10A maximum	
Terminals	Size	M4	M4	M4
	Type	Standard screw	Standard screw	Standard screw
Mounting	35mm DIN rail	35mm DIN rail	35mm DIN rail	
Terminal Torque	(N-m)	1.4 - 2.0	1.4 - 2.0	1.4 - 2.0
	(in-lbs.)	12.4 - 17.8	12.4 - 17.8	12.4 - 17.8
End Plate	BNE20	BNE20	BNE20	
DIN Rail Stop	BNL-5	BNL-5	BNL-5	
Dust Cover	—	—	—	
Marking Strip	BNM7	BNM7	BNM7	
Applicable Fuse Size	1/4" x 1-1/4" (6.35 x 31.8mm)	1/4" x 1-1/4" (6.35 x 31.8mm)	1/4" x 1-1/4" (6.35 x 31.8mm)	

-  1. BNDN1000 aluminum DIN rails are available in 1 meter lengths.
2. Fuses not included.

Dimensions

Switches & Pilot Lights

BNH Series

Part No.	Diagrams		
BNH10W BNH15MW			
BNH15LW BNH30W			
BNH50W			

Display Lights

Relays & Sockets

Timers

BN Series







Part No.	Diagrams		
BN75W BN150W			
BNF10SW BNF10NW BNW10DW			
BNDH15W			

Terminal Blocks

Circuit Breakers

Accessories

Part Numbers: End Plates, DIN Rail Stops, Stand-Offs, DIN Rail and Dust Covers

Description	Appearance	Use with	Part No.	Remarks
End Plates		BNH10W	BNE15W	
		BNH15MW		
		BNH15LW		
		BNH30W	BNE30W	
		BNF10SW	BNE20	
		BNF10NW		
		BNF10DW		
		BNH50W	BNE50W	
		BN75W	BNE75W	
		BN150W	BNE150W	
BNDH15W	BNDE15W			
DIN Rail Stops		BNH10W	BNL5 (small)	1. DIN rail stops prevent side-to-side movement. 2. The BNL-5 width is 0.375" (9mm).
		BNH15MW		
		BNH15LW		
		BNH30W		
		BNH50W		
		BNF10SW		
		BNF10NW		
		BNF10DW		
		BA111T		
		BA211T		
		BA311T		
		BA411S		
		BAF111SU		
BAF111SDU				
DIN Rail Stops		BN75W BN150W	BNL6 (medium)	1. DIN rail stops prevent side-to-side movement. 2. The BNL-6 width is 0.375" (9mm). 3. To firmly stabilize these higher profile terminal blocks, the BNL-6 has a higher profile than the BNL-5.
		BNDH15W BN200NW# BN400NW#	BNL8 (large)	1. DIN rail stops prevent side-to-side movement. 2. The BNL-8 width is 0.571" (14.5mm). 3. # = number of poles.
DIN Rail Stand-Offs		All series	BNS3	1.46" (37mm) height
			BNS4	3.03" (77mm) height
DIN Rail		All series	BNDN1000 (length 39.37" (1mm)	1. For calculating the rail lengths required, see the instructions on page 876. 2. The DIN rail material is aluminum.
Dust Covers		BNDH15W	BNC230	The overall length is 39.37" (1,000mm). The material is polycarbonate (UL94-V2).
		BNH10W		
		BNH15MW		
		BNH15LW		
		BNH30W	BNC320	
		BNH50W		
		BN75W		
		BN150W		
BN200	BAC820			
BN400	BNC1000			

Switches & Pilot Lights

Display Lights

Relays & Sockets

Timers

Terminal Blocks

Circuit Breakers

Accessories, continued

Part Numbers: Rods, Nuts, Marking Strips, Dust Covers, and Jumpers

Description	Appearance	Use with	Part No.	Remarks
Marking Strips		All series	BNM7	Material: polyvinyl chloride (PVC) Strip dimensions are 0.37" x 39" (9.5 x 1,000mm).
			BNM9	Material: fiberglass Strip dimensions are 0.37" x 39" (9.5 x 1,000mm).
Marking Strip Fastener		All series	BNM3	Used to prevent marking strips from sliding out.
Ring Terminal Jumpers		BNH10W	BNJ16	Jumpers come standard with 6 points.
		BNH15MW	BNJ26W	
		BNH15LW	BNJ46	
		BNH30W	BNJ56	
		BNDH15W	BNJ26W	
Fork Terminal Jumpers		BNH10W	BNJ16F	Note: insulated jumpers available - add "B" to end of part number. For example, BNJ26WB.
		BNH15MW	BNJ26FW	
		BNH15LW	BNJ46F	
		BNH30W	BNJ56F	
		BNDH15W	BNJ26FW	
Surface Mount Bracket		BNDH15W (dual-deck)	BNDL2	Used to surface mount dual-deck terminal blocks. (BNDL2).
M4 Thread Rod		BNDH15W	BNR1 (265mm)	1. Rod and connecting nuts are used to mount dual-decks collectively. 2. Each connecting nut set includes 1 hex connecting nut and 1 round connecting nut. 3. The BNR1 rod dimensions are 0.027" x 10.43" (0.7 x 265mm). 4. The BNR2 rod dimensions are 0.027" x 19.69" (0.7 x 500mm).
			BNR2 (500mm)	
Connecting Nuts		BNR1 BNR2	BNN1	
Terminal Block Removal Tool			BND2	



For accessory dimensions, see page 872.

Dimensions

Dimensions: DIN Rail

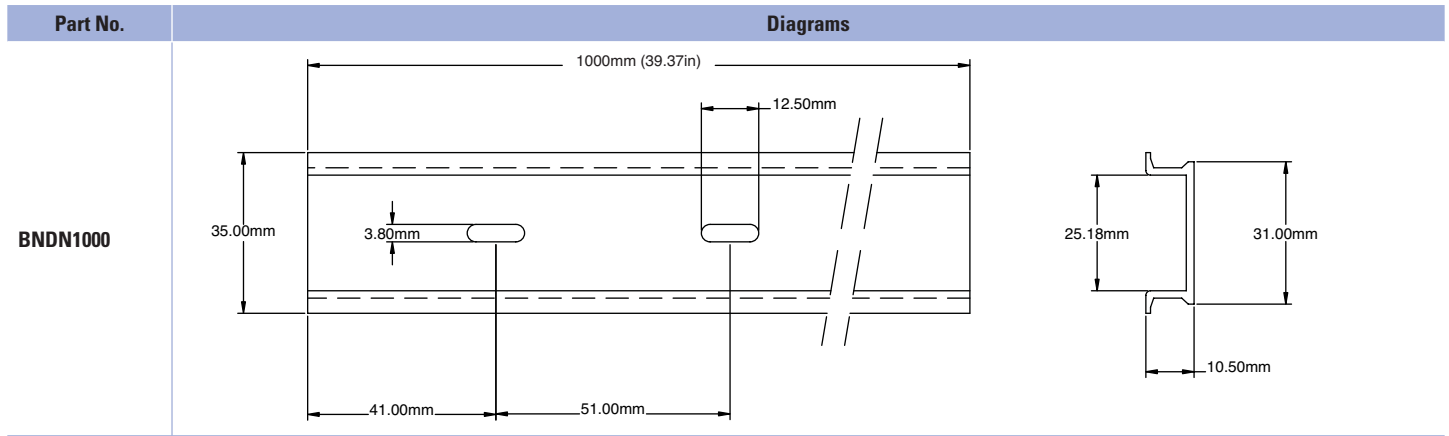

Dimensions: Jumpers

BNH Series

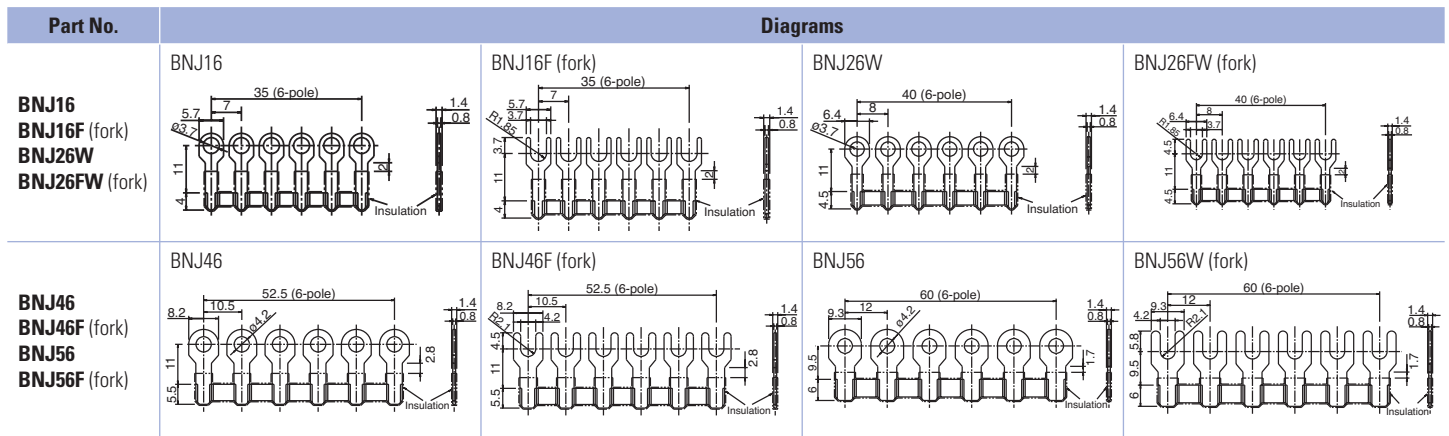

Thickness + 0.8mm (0.0315")

Switches & Pilot Lights

Display Lights

Relays & Sockets

Timers

Terminal Blocks

Circuit Breakers

Dimensions, continued

Dimensions, DIN Rail Stops and Stand-offs

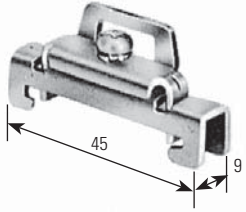
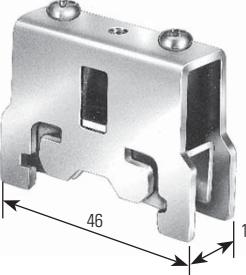
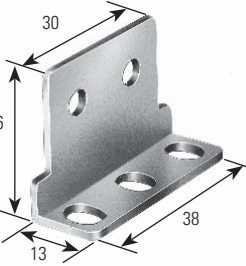
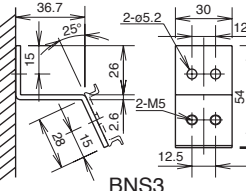
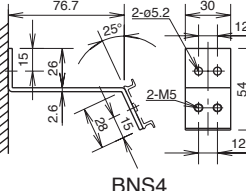
Part No.	Dimensions
BNL-6	 <p>BNL-6 shown, BNL-5 same except without back crossbar</p>
BNL-8	
BNDL2	
BNS3	 <p>BNS3</p>
BNS4	 <p>BNS4</p>

Switches & Pilot Lights

Display Lights

Relays & Sockets



Timers



Terminal Blocks

Circuit Breakers

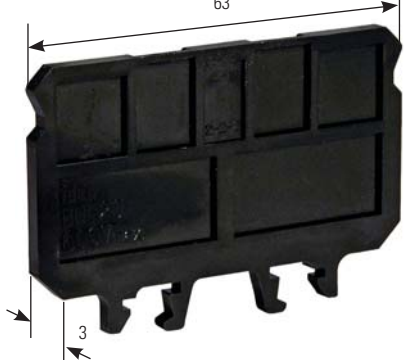
Dimensions, continued

Dimensions: End Plates

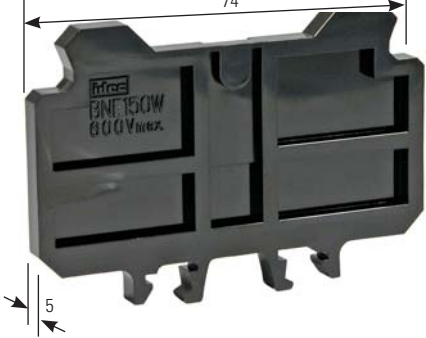
Part No.	Dimensions
BNE15W	
BNE20	
BNE30W	
BNE50W	

Part No.	Dimensions
BNE75W	
BNE150W	
BNDE15W	

Switches & Pilot Lights

Display Lights

Relays & Sockets

Timers

Terminal Blocks

Circuit Breakers

Instructions

Wiring Touch-Down Terminal Blocks: BNH Series

Instructions	Step 1	Step 2	Step 3	Step 4
<p>Step 1. Insert the wire (or crimping terminal) into the terminal block with the terminal screws in the open position. (Use of crimping terminals is optional.)</p> <p>Step 2. Push the terminal screw down to hold the wire in place.</p> <p>Step 3. Hold the terminal screw down, and tighten with a screwdriver.</p> <p>Step 4. To remove the wire, loosen the terminal screw and pull up until wire is released.</p>				

Installation and Removal of Terminal Blocks

Instructions	Appearance
<p>Step 1. Slide the terminal blocks onto the DIN rail from one end.</p> <p>Step 2. Use BNL5 or BNL6 end clips to secure the terminal block row and to prevent side-to-side movement. BNH10W, BNH15MW, BNH15LW, and BNH30W can be installed from the middle of a DIN rail.</p> <p>Step 3. To install, place the terminal block on top of the DIN rail and push down until both edges of the terminal block snap onto the DIN rail.</p> <p>Step 4. To remove the terminal block, use the BND2 removal tool as shown on the right.</p>	<p>Removal Tool BND2</p>

Mounting Double-Deck Terminal Blocks

Instructions	Appearance
<p>DIN Rail Mount:</p> <p>Step 1. First install the end plate. Then mount the terminal blocks onto the DIN rail.</p> <p>Step 2. To prevent side-to-side movement on the DIN rail, use the BNL-8 mounting clip at both ends of the rail.</p>	
<p>Panel Mount:</p> <p>Step 1. Assemble a row of terminal blocks with end plates on exposed end(s).</p> <p>Step 2. Use BNDL2 mounting clips at both ends of a row.</p> <p>Step 3. With the two holes of the mounting clip aligned with the terminal block holes, insert a connecting rod through each hole.</p> <p>Step 4. Secure the ends of the connecting rods with the connecting nuts, as shown below.</p>	

Switches & Pilot Lights

Display Lights

Relays & Sockets

Timers

Terminal Blocks

Circuit Breakers

Calculating DIN Rail Lengths

Instructions	Appearance
<p>Step 1. Add widths of all terminal blocks (reference pages 864 through 869).</p> <p>Step 2. Add the endplate thickness (usually only one).</p> <p>Step 3. Add the DIN rail stop widths (usually two are used).</p> <p>Step 4. Round to the nearest 2" (50mm) increment to allow for DIN rail hole spacing.</p> <p>Step 5. Add 1" (25mm) to ensure 0.5" (12.5mm) of clearance at each end of the DIN rail.</p>	

DIN Rail Stop Dimensions

Part No.	Width
BNL-5	.374" (9mm)
BNL-6	.374" (9mm)
BNL-8	.571" (14.5mm)

Torque Specifications

Screw Size	M3	M3.5	M4	M5	M6	M8	M10	M12	Diagram	
Torque	(N-m)	0.6 to 1.0	1.0 to 1.3	1.4 to 2.0	2.6 to 3.7	3.9 to 5.4	10 to 13.5	21 to 28	38 to 49	
	(kgf-cm)	6.1 to 10.2	10.2 to 13.3	14.3 to 20.4	26.5 to 37.7	39.8 to 55.1	102 to 138	214 to 286	388 to 500	
Dimension A	0.257" (6.6mm)	0.332" (8.5mm)	0.371" (9.5mm)	0.499" (12.8mm)	0.655" (16.8mm)	0.890" (22.8mm)	1.279" (32.8mm)	1.981" (50.8mm)		
Dimension B	0.129" (3.3mm)	0.156" (4mm)	0.176" (4.5mm)	0.176" (4.5mm)	0.234" (6mm)	0.312" (8mm)	0.429" (11mm)	0.546" (14mm)		
Dimension C	0.195" (5mm)	0.195" (5mm)	0.234" (6mm)	0.254" (6.5mm)	0.332" (8.5mm)	0.429" (11mm)	0.624" (16mm)	1.014" (26mm)		
Dimension D	Ø 0.125" (3.2mm)	Ø 0.140" (3.6mm)	Ø 0.164" (4.2mm)	Ø 0.203" (5.2mm)	Ø 0.242" (6.2mm)	Ø 0.332" (8.5mm)	Ø 0.410" (10.5mm)	Ø 0.488" (12.5mm)		

Rated Current

Applicable Wire	Rated at 60°C	Applicable Wire	Rated at 60°C
22 AWG (0.3mm ²)	3A	6 (14mm ²)	50A
20 AWG (0.5mm ²)	5A	4 (22mm ²)	75A
18 AWG (0.75mm ²)	7A	0 (38mm ²)	100A
16 AWG (1.25mm ²)	10A	00 (60mm ²)	150A
14 AWG (2mm ²)	15A	0000 (100mm ²)	200A
12 (3.5mm ²)	20A	300mcm (150mm ²)	300A
10 (5.5mm ²)	30A	400mcm (200mm ²)	350A

UL/CSA ratings are specified. The current carrying capacity depends on the rating of the wire used, as shown.

Switches & Pilot Lights

Display Lights

Relays & Sockets

Timers

Terminal Blocks

Circuit Breakers