

OpenNet Controller



Programming Software; WindLDR®

- Programs all IDEC PLCs
- Windows-based (compatible with Windows 95, 98, 2000, NT 4.0, ME, XP or Vista)

Features:

- Digital I/O
 - 8, 16, and 32 point cards
 - 224 inputs and outputs, 480 with expansion power supply
- Analog I/O
 - up to 42 analog inputs or 14 analog outputs
 - 0-5V, 0-10V, ±5V, ±10V, 4-20mA
- Built-In Communications Ports
 - 2 RS232 (programming port, ASCII, printer and modem ready)
 - 1 RS485 (programming port and data link)
- Built-in High-Speed Counter
 - 1 channel, 10kHz, 16-bit resolution
- Memory
 - 16K words (8K steps) user program capacity
- Realtime Calendar/Clock
- Password Protection
- PID Algorithm

Programming Instructions

- Transmit/Receive
- Built-in X/Y Conversion
- Sub-Routine Call/Return for Modular Programming
- Square Root
- 16- and 32-bit Math, Add, Sub, Mult, Div
- Data Conversion to/from Dec, Hex, BCD, ASCII
- Block Move
- Summation
- Averaging
- Day of Week Program Scheduling

Built-in Hayes "AT" command set for modem dialup/pager application

Hardware Features

CPUs	FC3A-CP2K	High-speed counter sink output
	FC3A-CP2S	High-speed counter source output
Electrical Specifications	Rated Voltage	24V DC (19-30V DC, including ripple)
	Maximum Input Current	1.5A at 24V DC
	Reverse Polarity Protection	Prevents damage if incorrectly wired.
	Operating Temperature	0 to +55°C
	Storage Temperature	-25 to +70°C
	Relative Humidity	30 to 95% RH (non-condensing)
	Vibration Resistance	10 to 57 Hz, amplitude 0.075mm 57 to 150 Hz 9.8 m/sec ² (1G) 10 sweep cycles/axis (IEC 1131)
	Shock Resistance	147 m/sec ² (15G), 11ms 3 shocks each in 3 axes (IEC 1131)
	Dielectric Strength	Between power terminal and FG: 500V AC, 1 min Between I/O terminal and FG: 1500V AC, 1 min
	Ground	Grounding resistance 100Ω (maximum)
	Mounting Style	35mm DIN rail



 The eighth slot must be an expansion power supply module. (Photo is only an example of the range of available modules.)

	Standard ONC CPU
Available Instructions	37 basic, 65 advanced (PID, square root, subroutine calls, etc.)
User Program Capacity	16K words flash memory
Average Scan Time	1 ms or greater
Input	224 points (I0-I277)
Output	224 points (Q0-Q277)
Total I/O Points	Using expansion power supply: 480 I/O points
Internal Relay	2048 (M0-M2557)
Special Internal Relay	192 (M8000-M8237)
Shift Register	256 (R0-R255)
Timer	256 (T0-T255; 1-sec, 100-msec, 10-msec, 1-msec)
Counter	256 (C0-C255; adding, dual pulse reversible, up/down selection reversible)
Data Register	8000 (D0-D7999)
Link Register	256 master (L1000 - L1317), 168 slave (L100 - L127, L200 - L227,, L700 - L727)
Remote I/O	512 points
Real-Time Calendar/Clock Runtime	Yes
Program Protection	Yes (password protected)
External Run/Stop Control	Yes
Power Failure Protection	Yes
Self-Diagnostics	Yes
Auto Start Function	Yes

Part Numbers

Item	Description	Part Number	
CPU Modules	High-speed counter, sink output	FC3A-CP2K	
	High-speed counter, source output	FC3A-CP2S	
Input Modules	DC Input	16 points 24V DC input, sink/source compatible, terminal block	FC3A-N16B1
		16 points 24V DC input, sink/source compatible, nylon connector	FC3A-N16B3
		32 points 24V DC input, sink/source compatible, nylon connector	FC3A-N32B4
		32 points 24V DC input, sink/source compatible, FUJITSU connector	FC3A-N32B5
	AC Input	8 points 100V AC input, terminal block	FC3A-N08A11
Analog Input	6 channels, 4-20mA, selectable by DIP sw, terminal block	FC3A-AD1261	
	2 channels, 4-20mA, selectable by DIP sw, terminal block	FC3A-DA1221	
Output Modules	Relay Output	16 points relay output, terminal block	FC3A-R161
		16 points relay output, nylon connector	FC3A-R162
	Transistor Output	16 points transistor output sink, terminal block	FC3A-T16K1
		16 points transistor output sink, nylon connector	FC3A-T16K3
		16 points transistor output protect source, terminal block	FC3A-T16P1
		32 points transistor output sink, nylon connector	FC3A-T32K4
		32 points transistor output sink, FUJITSU connector	FC3A-T32K5
	Expansion Module	Expansion power supply	FC3A-EA1
	Network Interface Modules	Remote I/O Master Module	FC3A-SX5SM1
IDEC-Modbus Converter Package (see Communication & Networking section for details)		IDEC-MBUS-CONVPCK	
Accessories	Housing (4 pcs/bag) for FC3A-R162	VHR-5N	
	Housing (2 pcs/bag) for FC3A-T16K3, -N16B3	VHR-10N	
	Housing (2 pcs/bag) for FC3A-T32K4, -N32B4	H18-SHF-AA	
	Pins (40 pcs/bag) for FC3A-T32K4, -N32B4	SHF-001T-0.8BS	
	Pins (20 pcs/bag) for FC3A-R162/T16K3, -N16B3	SVH-21T-P1.1	
	Cable with Fujitsu connector (for FC3A-T32K5/N32B5)	FC3A-KUSA1	
	Breakout Module (for FC3A-T32K5, -N32B5)	BX1D-T40A or BX1D-S40A	
Software	Windows-based programming software for IDEC PLCs - WindLDR	FC9Y-LP2CDW*	
	Software application to link OPC/DDE compliant windows applications to IDEC PLCs (for more information see Communication Section)	WINDSRV†	
Programming Cable	Cable to connect ONC to PC	FC2A-KC4C	
Manuals	ONC User Manual	EM345-0	



- *For more information on WindLDR see page 23 and the Automation Software section.
- †For more information on WindSRV see the Automation Software section.

PLCs

Operator Interfaces

Automation Software

Power Supplies

Sensors

Communication & Networking

OpenNet Controller, Networking & Applications

PLCs

PC Communication

The ONC is programmed by our intuitive WindLDR™ software

- use RS232 or RS485 ports
- upload, download and monitor programs

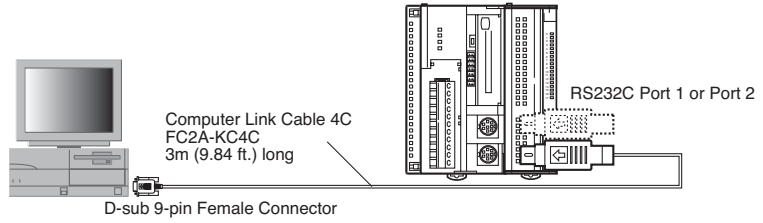

Operator Interfaces

Data Link - Superiority in Networking

Connect up to 32 ONC PLCs or the HG Series operator interface on a data link network.

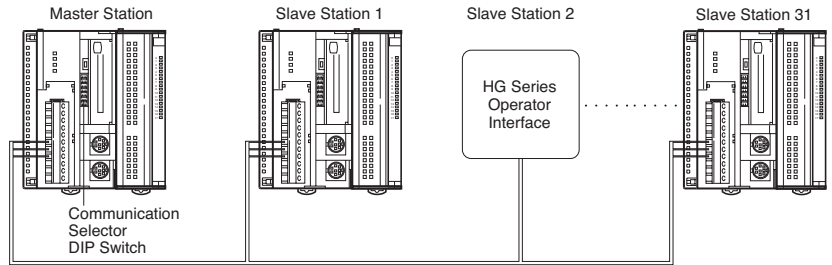

Automation Software

Computer Link - Power & Versatility

Connect 32 ONCs on a 1:N computer link system. Upload, download, monitor, and update data.

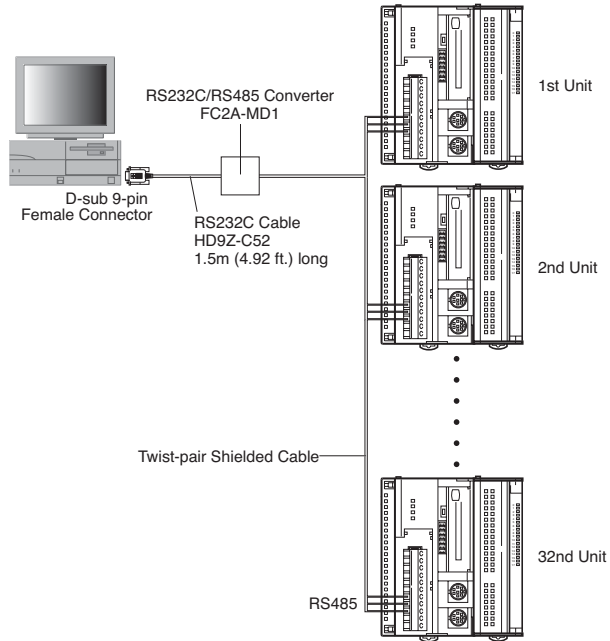

Power Supplies

Sensors

Communication Flexibility

Easy connections to any R232C equipment through the user defined RS232C port 1 or 2. Built-in Hayes "AT" command set for direct modem dialup and pager applications.

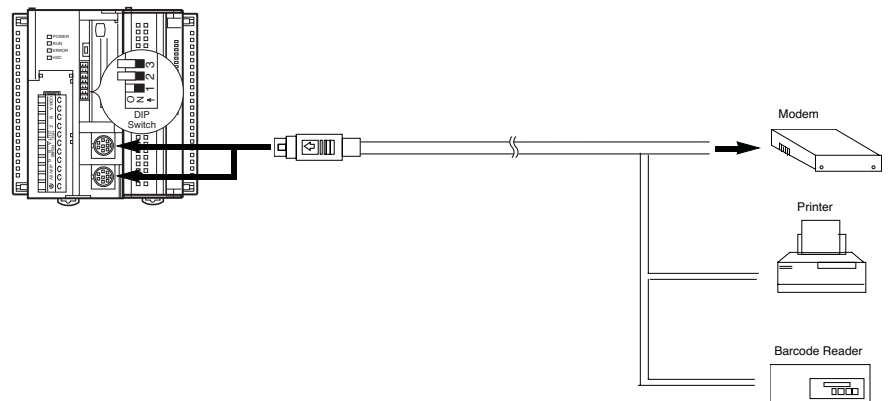

Communication & Networking

Analog Input and Output Modules



Analog Output Module
FC3A-DA1221

Features:

- One card handles 5 different signal types, [$\pm 5V$, $\pm 10V$, $0-5V$, $0-10V$, or $4-20mA$], switch selectable
- Input module has 6 inputs per card, 7 cards per CPU, 42 analog input points maximum
- Output module has 2 outputs per card, 7 cards per CPU, 14 analog output points maximum
- 12-bit resolution, 0-4000 counts, count range divides evenly
- Fast input scan, 3ms + 1 scan time
- I/O error $\pm 0.6\%$ full scale @25°C
- Convenient input termination

Specifications

Analog	Input	Output
Points Per Card	6	2
Part Number	FC3A-AD1261	FC3A-DA1221
Connector	Removable screw terminal blocks	Removable screw terminal blocks
Input Signal	0-10V DC, $\pm 10V$ DC, 0-5V DC, $\pm 5V$ DC, 4-20mA	0-10V DC, $\pm 10V$ DC, 0-5V DC, $\pm 5V$ DC, 4-20mA
Resolution	12 bits	12 bits
Range	0-4000 counts	0-4000 counts
Input Error	$\pm 0.6\%$ of full scale @ 25°C	NA
Output Error	NA	$\pm 0.6\%$ of full scale @ 25°C
Conversion Time	3ms per point	NA
Settling Time	NA	3ms
Input Impedance	Voltage: 1 M Ω minimum Current: 250 Ω	NA
Output Load Impedance	NA	Voltage=2 k Ω minimum (Current=250 Ω , 300 Ω max.)
Internal Current Draw	120mA@24V DC	120mA@24V DC

Type of Protection

Analog Input Module

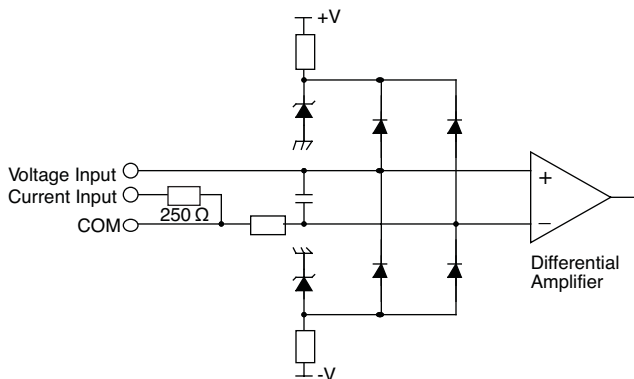

Analog Output Module

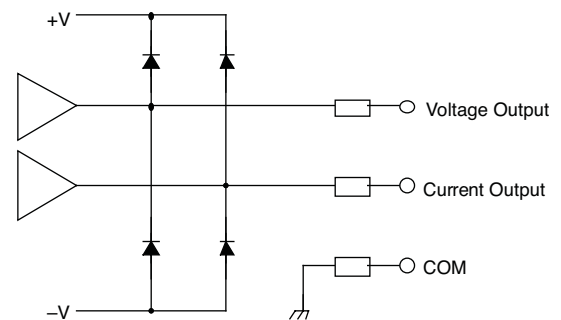

16-Point DC Input Modules



DC Input Module
FC3A-N16B1

DC Input Module
FC3A-N16B3

Features:

- One card handles sink (NPN) or source (PNP) input signals
- 16 points per card, 7 cards local, 8 cards expansion, 15 cards max. per CPU
- 19-30V DC input voltage range
- Software selectable input filtering, 0-32 msec
- High-speed catch inputs, first 8 points user definable, pulse detection within 20-120µsec range
- Termination connector
 - FC3A-N16B1 - removable screw terminal blocks
 - FC3A-N16B3 - removable nylon pin connector

Specifications

Input	DC Sink/Source	
Part Number	FC3A-N16B1	FC3A-N16B3
Connector	Screw terminal blocks	Nylon pins
Input Voltage Range	19-30V DC	19-30V DC
Input Voltage	24V DC	24V DC
Current Per Point	7mA	7mA
Internal Current - all inputs ON	40mA	40mA
Input Impedance	3.4kΩ	3.4kΩ
On/Off Voltage	15/5V DC	15/5V DC
On/Off Time	20/120µs	20/120µs

32-Point DC Input Modules



DC Input Module
FC3A-N32B4

DC Input Module
FC3A-N32B5

Features:

- One card handles sink (NPN) or source (PNP) input signals
- 16 points per card, 7 cards local, 8 cards expansion, 15 cards max. per CPU
- 20-30V DC input voltage range
- Software selectable input filtering, 0-32 msec
- High-speed catch inputs, first 8 points user definable, pulse detection within 20-120µsec range
- Termination connector
 - FC3A-N32B4 - removable nylon pin connector
 - FC3A-N32B5 - Fujitsu connector

Specifications

Input	DC Sink/Source	
Part Number	FC3A-N32B4	FC3A-N32B5
Connector	Nylon	Fujitsu
Input Voltage Range	20-28V DC	20-28V DC
Input Voltage	24V DC	24V DC
Current Per Point	5mA	5mA
Internal Current - all inputs ON	50mA	50mA
Input Impedance	4.7kΩ	4.7kΩ
On/Off Voltage	15/5V DC	15/5V DC
On/Off Time	20/120µs	20/120µs

8-Point AC Input Module



AC Input Module
FC3A-N08A11

Features:

- 8 points per card, 7 cards local, 8 cards expansion, 15 cards max. per CPU
- 100-120V AC rated input voltage
- 85-132V AC input voltage range
- On/off detection set at 20ms
- Convenient termination connector, removable screw terminal blocks

Specifications

Input	AC
Part Number	FC3A-N08A11
Connector	Removable screw terminal blocks
Input Voltage Range	85-132V AC
Input Voltage	100-120V AC
Current Per Point	8mA
Internal Current - all inputs ON	30mA
Input Impedance	12kΩ (60Hz)
On/Off Voltage	79/20V AC
On/Off Time	20ms

Input Operating Range

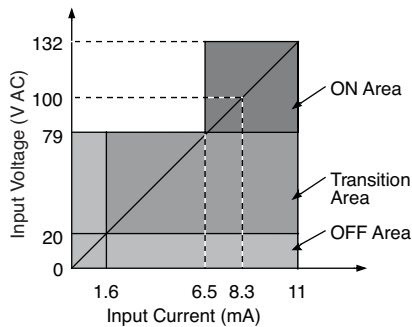

Input Internal Circuit

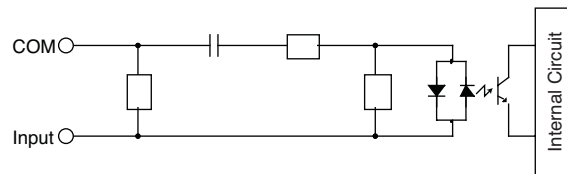

16-Point Relay Output Modules

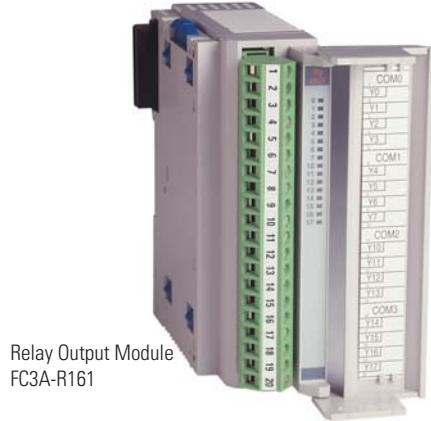

Relay Output Module FC3A-R162

Features:

- 16 points per card, 4 points per common, 15 cards max. per CPU
- Outputs rated 240V AC/2A or 24V DC/2A
- Turn On/Off delay 6-10ms
- 20,000,000 operations per relay minimum
- Termination connector
 - FC3A-R161 - removable screw terminal blocks
 - FC3A-R162 - removable nylon pin connectors

Specifications

Output	Relay Output	
Part Number	FC3A-R161	FC3A-R162
Connector	Removable screw terminal blocks	Nylon pin
Output Voltage	240V AC/24V DC	240V AC/24V DC
Current Per Point	2A	2A
Internal Current - all inputs ON	170mA	170mA
On/Off Time	6/10ms	6/10ms

16-Point DC Sink Output Modules

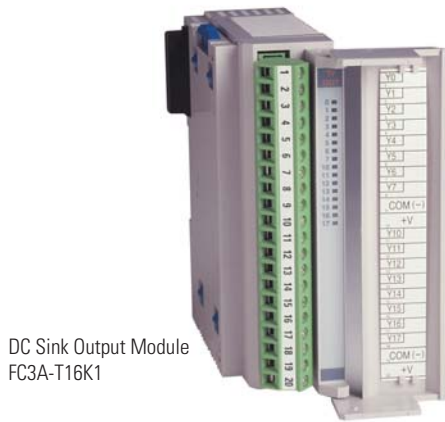

DC Sink Output Module FC3A-T16K3

Features:

- 16 transistor sink outputs per card, 15 cards max. per CPU
- Outputs rated 19-30V DC/0.5A
- Turn On/Off delay 500µsec max.
- Opto-isolated outputs
- Termination connector
 - FC3A-T16K1 - removable screw terminal blocks
 - FC3A-T16K3 - removable nylon pin connectors

Specifications

Output	DC Sink	
Part Number	FC3A-T16K1	FC3A-T16K3
Connector	Removable screw terminal blocks	Nylon pin
Output Voltage	19-30V DC	19-30V DC
Current Per Point	500mA@ 24V DC	500mA@ 24V DC
Internal Current - all inputs ON	60mA	60mA
On/Off Time	500/500µs	500/500µs

16-Point DC Protect Source Output Module



Protect Source Output Module
FC3A-T16P1

Features:

- 16 transistor protect source outputs per card, 15 cards max. per CPU
- Outputs rated 19-30V DC/0.5A
- Turn On/Off delay 500µsec max.
- Opto-isolated outputs
- Termination connector, removable screw terminal blocks

Specifications

Output	DC Source
Part Number	FC3A-T16P1
Connector	Removable screw terminal blocks
Output Voltage	19-30V DC
Current Per Point	500mA @ 24V DC
Internal Current - all inputs ON	70mA
On/Off Time	500µs/500µs

32-Point DC Input Modules



DC Sink Output Module
FC3A-T32K4



DC Sink Output Module
FC3A-T32K5

Features:

- 32 transistor sink outputs per card, 15 cards max. per CPU
- Outputs rated 20.4-27.6V DC/0.1A
- Turn On/Off delay 500µsec max.
- Opto-isolated outputs
- Termination connector
 - FC3A-T32K4 - removable nylon pin connector
 - FC3A-T32K5 - removable Fujitsu connector

Specifications

Output	DC Sink	
Part Number	FC3A-T32K4	FC3A-T32K5
Connector	Nylon pin	Fujitsu
Output Voltage	20.4-27.6V DC	20.4-27.6V DC
Current Per Point	100mA@24V DC	100mA@24V DC
Internal Current - all inputs ON	90mA	90mA
On/Off Time	500/500µs	500/500µs

Expansion Power Supply Module



Expansion Power Supply Module
FC3A-EA1

Features:

- Expands the ONC from 224 up to 480 I/O points
- Increases I/O and functional modules by 8
- Comes with a cable connector and contacts
- Simple, easy and convenient mounting
- Install in the 8th slot only

Specifications

Part Number	FC3A-EA1
Connector	Nylon - 5 pin
Input Voltage Range	19 - 30V DC (including ripple)
Input Voltage	24V DC
Internal Current	30mA
Momentary Power Interruption	10 msec (24V DC), Level PS-2 (EN61131)

Power Supply Wiring

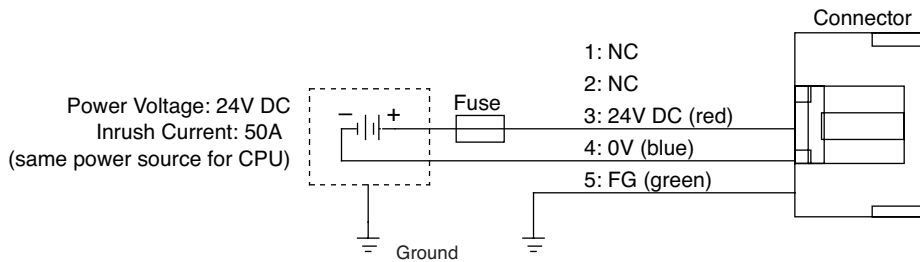

FC3A-EA1 Expansion Power Supply Module Mounting Position

Mount the expansion power supply module in the eighth slot

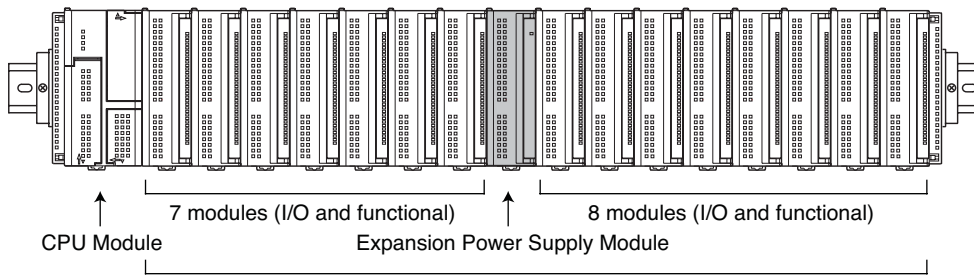

A maximum of 7 functional modules can be mounted in any of 15 slots



Mount the expansion power supply module only in the eighth slot, otherwise correct allocation of I/O and link register numbers may not occur.

Dimensions

CPU Module

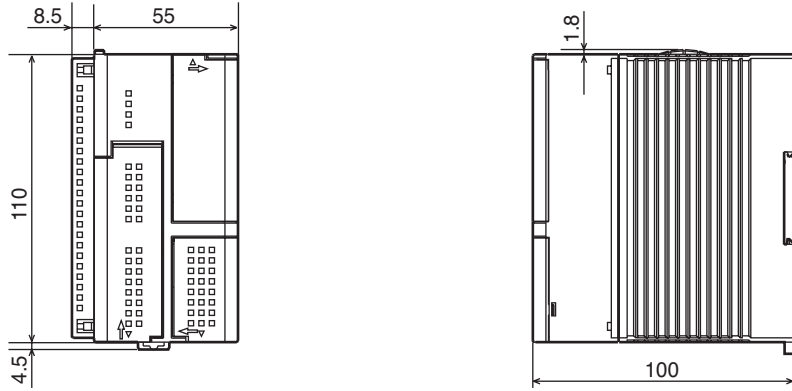

Digital I/O, Analog I/O, Expansion Power Supply

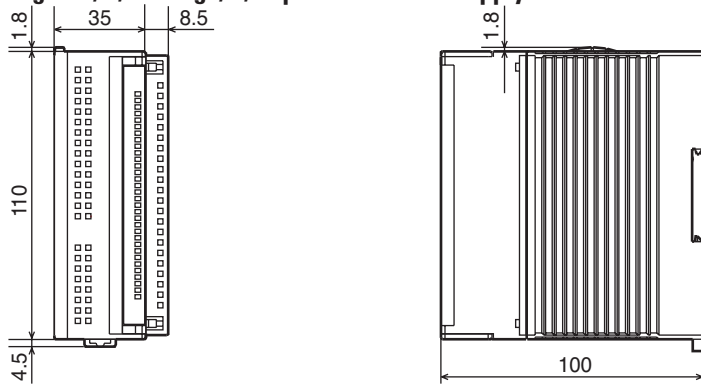

Example: the following figure illustrates a system setup consisting of a remote I/O master module, a CPU module, and three I/O modules.

