

# OHIO MODEL CDS AUTO/MANUAL DROP MAGNET CONTROLLER

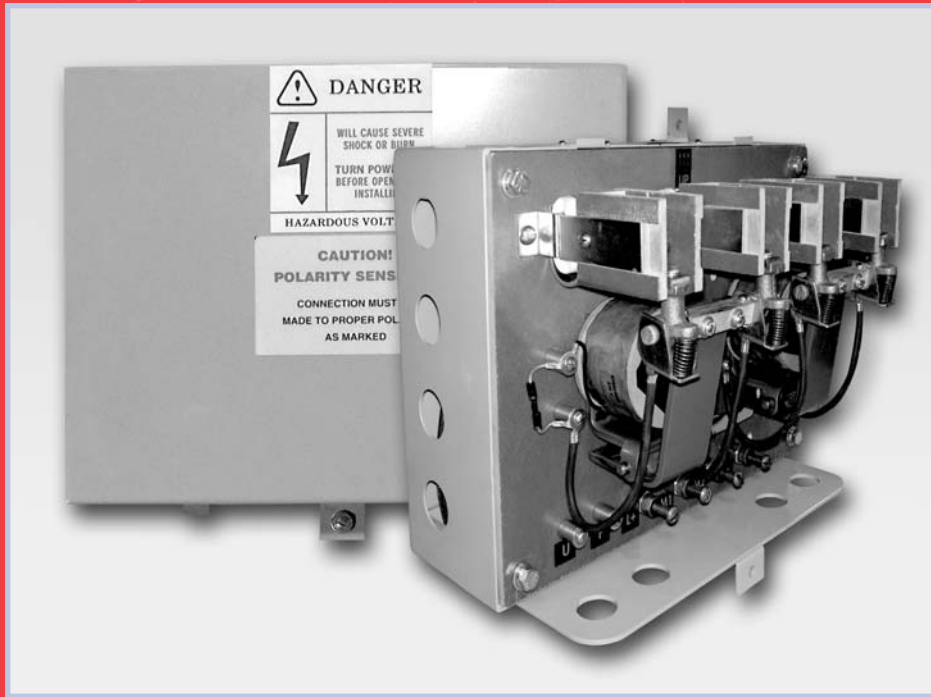

## INSTALLATION, MAINTENANCE, AND PARTS BULLETIN

### OPERATING RANGE

Manual 1-20 A (COLD MAGNET CURRENT)

Automatic 5-20 A (COLD MAGNET CURRENT)

## DESCRIPTION

The CDS Controller is a low current, heavy duty magnet controller used for magnets from 20 A down to 1.0 A cold current. Cold current references the current flowing through the magnet when the magnet temperature is 25°C throughout. The CDS controller uses many parts interchangeable with a higher range controllers for lower inventory costs.

### AUTOMATIC DROP

There is no reverse current adjustment. The amount of reverse current is automatically adjusted for fast, clean drop of scrap material with one movement of the master switch or push button.

### MANUAL DROP

Allows for partial dropping of the load by controlling the amount of reverse current to the magnet. A drop position on the master switch or a push button that is spring returned to off, gives the operator complete control of the drop cycle. It also accommodates the use of very low amperage magnets.

## INSTALLATION PROCEDURES

- Mount the controller to a solid surface with the mounting bars provided.
- The controller must be mounted vertically with the "TOP" up to operate properly.
- Mount the controller away from sources of heat and direct exhaust of engines.
- Allow enough room around the controller for air circulation.
- Route electrical wires through bottom of the enclosure and connect securely to the terminals.
- All electrical circuits must be free from grounds and shorts.

# OHIO MODEL CDS AUTO / MANUAL DROP MAGNET CONTROLLER

## CDS CONTROLLER EXPLODED ASSEMBLY VIEW

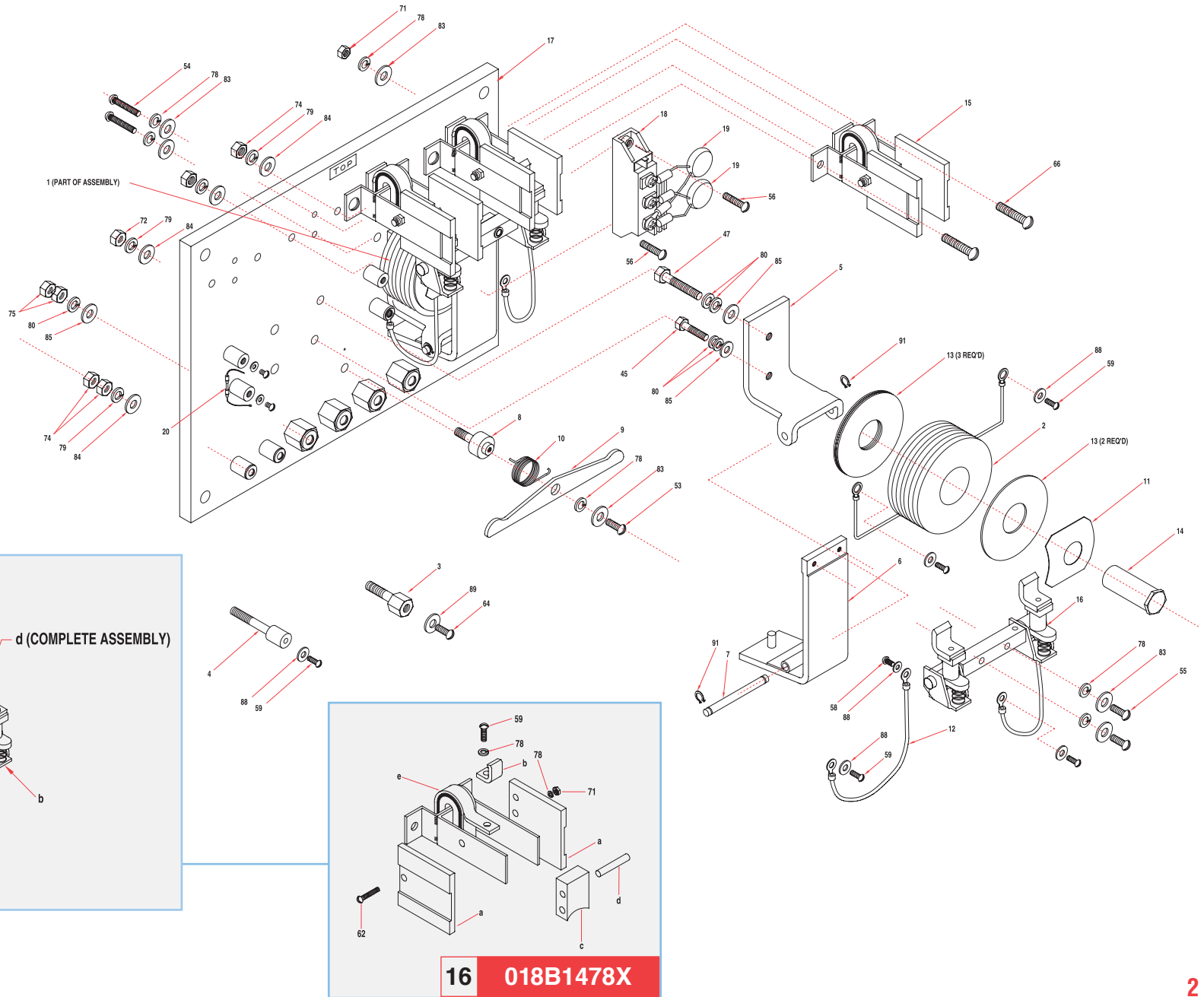

# OHIO MODEL CDS HARDWARE PART LIST

ITEM	PART NUMBER	REQ A230	REQ M230	REQ 0-230	REQ A115	REQ M115	REQ 0-115	DESCRIPTION	ITEM	PART NUMBER	REQ A230	REQ M230	REQ 0-230	REQ A115	REQ M115	REQ 0-115	DESCRIPTION	ITEM	PART NUMBER	REQ A230	REQ M230	REQ 0-230	REQ A115	REQ M115	REQ 0-115	DESCRIPTION		
1	018A1508A	1		1		1		REVERSE SWITCH COIL – 36 V-dc	16	018B5074X	2	2	2	2	2	2	SWITCH ARM ASSEMBLY	64	A-900025-16	4	4	4	4	4	4	SCR RH SLOTTED: 1/4-20 x 0.38 UNC	BRASS	
1	018A1508D		1					REVERSE SWITCH COIL – 230 V-dc	16a	018A1443X	4	4	4	4	4	4	CONTACT TIP	66	A-900025-21	8	8	8	8	8	8	SCR RH SLOTTED: 1/4-20 x 1.25 UNC	BRASS	
1	018A1508C				1			REVERSE SWITCH COIL – 115 V-dc	16b	018A2604A	2	2	2	2	2	2	CONTACT BRACKET	71	A-900106-03	6	6	6	6	6	6	NUT HEX: #10-32 UNF	STEEL	
2	018A1508D	1	1	1				OPERATING COIL – 230 V-dc	16c	018A2605A	2	2	2	2	2	2	CONTACT BRACKET	72	A-900106-05	1	1	1	1	1	1	NUT HEX: 1/4-20 UNC	STEEL	
2	018A1508C				1	1	1	OPERATING COIL – 115 V-dc	16d	018A2614A	4	4	4	4	4	4	CONTACT ARM ASSEMBLY	74	A-900108-11	27	28	27	27	28	27	NUT HEX JAM: 1/4-20 NC	STEEL	
3	018A1510X	4	4	4	4	4	4	TERMINAL STUD	16e	018A2614X	4	4	4	4	4	4	CONTACT ARM ASSEMBLY	75	A-900108-12	8	8	8	8	8	8	NUT HEX JAM: 5/16-18 NC	STEEL	
4	018A1511X	10	11	10	10	11	10	TERMINAL STUD	16f	018A2618X	2	2	2	2	2	2	REVERSE ARM SHAFT	78	A-900115-03	25	25	25	25	25	25	LOCKWASHER SPLIT: #10	STEEL	
5	018A2615X	2	2	2	2	2	2	SWITCH FRAME	16g	018A2625X	4	4	4	4	4	4	CONTACT SPRING	79	A-900115-05	19	20	19	19	20	19	LOCKWASHER SPLIT: 1/4	STEEL	
6	018A2622X	2	2	2	2	2	2	SWITCH ARM ASSEMBLY	16h	018A2631X	4	4	4	4	4	4	SPACER WASHER	80	A-900115-06	10	10	10	10	10	10	LOCKWASHER SPLIT: 5/16	STEEL	
7	018A2623A	2	2	2	2	2	2	ARM PIN: $\phi$ 0.25 in 6 mm	17	018C2643X	1	1	1	1	1	1	PANEL	83	A-900118-03	13	13	13	13	13	13	FLATWASHER: #10	STEEL	
8	018A2626X	1	1	1	1	1	1	INTERLOCK PIN	18	A-900550-26	1	1	1	1	1	1	DIODE MODULE	84	A-900118-05	19	20	19	19	20	19	FLATWASHER: 1/4	BRASS	
9	018A2628X	1	1	1	1	1	1	INTERLOCK BAR	19	018A2966Q	2	2	2	2	2	2	SUPPRESSOR ASSEMBLY	85	A-900118-06	8	8	8	8	8	8	FLATWASHER: 5/16	BRASS	
10	018A2629X	1	1	1	1	1	1	INTERLOCK SPRING	20	018A2966Z	1	1		1	1		CONTROL DIODE	88	A-900118-18	14	15	14	14	15	14	FLATWASHER: #10	BRASS	
11	018A2637X	2	2	2	2	2	2	SPRING WASHER	45	A-900007-04	2	2	2	2	2	2	SCR HEX HEAD: 5/16-18 x 1.00 UNC	STEEL	89	A-900118-20	4	4	4	4	4	4	FLATWASHER: 1/4	BRASS
12	018A2720X	4	4	4	4	4	4	SHUNT ASSEMBLY	47	A-900007-06	2	2	2	2	2	2	SCR HEX HEAD: 5/16-18 x 1.5 UNC	STEEL	90	A-900021-23	4	4	4	4	4	4	SCR RH SLOTTED: #8-32 x 0.75 UNF	BRASS
13	018A2977X	10	10	10	10	10	10	SEPERATOR WASHER	53	A-900023-03	1	1	1	1	1	1	SCR RH SLOTTED: 10-32 x 0.38 UNF	STEEL	91	A-900219-02	4	4	4	4	4	4	EXTERNAL RETAINER RING: SHAFT 1/4	STEEL
14	018A6209A	2	2	2	2	2	2	REVERSE CORE ASSEMBLY	54	A-900023-06	8	8	8	8	8	8	SCR RH SLOTTED: 10-32 x 0.75 UNF	STEEL	100	A-900115-28	4	4	4	4	4	4	LOCKWASHER SPLIT: M4	STEEL
15	018A1478X	4	4	4	4	4	4	BLOWOUT COIL ASSEMBLY	55	A-900023-07	4	4	4	4	4	4	SCR RH SLOTTED: 10-32 x 0.88 UNF	STEEL	106	105B009F01	1			1			CDS PANEL WIRE KIT AUTOMATIC	
15a	018A0803X	8	8	8	8	8	8	ARC SHIELD SIDE	56	A-900023-09	2	2	2	2	2	2	SCR RH SLOTTED: 10-32 x 1.25 UNF	STEEL	107	105B009F02		1		1			CDS PANEL WIRE KIT MANUAL	
15b	018A1443X	4	4	4	4	4	4	CONTACT TIP	58	A-900023-13	4	4	4	4	4	4	SCR RH SLOTTED: 10-32 x 0.31 UNF	BRASS	108	105B009F03			1		1		CDS PANEL WIRE KIT AUTOMATIC V.V	
15c	018A1503X	4	4	4	4	4	4	ARC SHIELD SPACER	59	A-900023-14	14	15	14	14	15	14	SCR RH SLOTTED: 10-32 x 0.38 UNF	BRASS	110	105B012C01	1	1	1	1	1	1	CDS RESISTOR WIRE KIT (NEMA 1)	
15d	018A1523X	4	4	4	4	4	4	DOWEL	60	A-900023-15	4	4	4	4	4	4	SCR RH SLOTTED: 10-32 x 0.50 UNF	BRASS	111	105B012C02	1	1	1	1	1	1	CDS RESISTOR WIRE KIT (NEMA 12/3R)	
15e	018B2727X	4	4	4	4	4	4	BLOWOUT COIL ASSEMBLY	62	A-900023-25	4	4	4	4	4	4	SCR RH SLOTTED: 10-32 x 1.75 UNF	BRASS	112									

## STEP BY STEP CONTROLLER OPERATION

### AUTOMATIC CONTROLLER

- When a lift signal is given by closing the contacts between terminals “F” and “U”, the “L” coil is energized.
- This closes the “L” contacts which supplies full power to the magnet.
- The blocking diode and the mechanical interlock (when adjusted properly) prevent the drop contactor from engaging during the lift cycle.
- When a drop signal is given the “F” to “U” contact is broken and the “L” coil is de-energized.
- This opens the “L” contacts discharging the magnet through resistors R2, R3, R4, and the drop coil “D”.
- This causes the drop contacts to close.
- Reverse voltage is then applied to the magnet through the “R1” and “R5” resistors.
- As the reverse current builds up through the magnet, the voltage across M2 and M1 decrease because of the increased voltage drop across R1 and R5. When the voltage becomes low enough across M2 and M1 the drop contactor opens and removes power from the magnet.

### MANUAL CONTROLLER

- When a lift signal is given by closing the contacts between terminals “F” and “U”, the “L” coil is energized.
- This closes the “L” contacts which supplies full power to the magnet.
- The blocking diode and the mechanical interlock (when adjusted properly) prevent the drop contactor from engaging during the lift cycle.
- When a drop signal is given the “F” to “U” contact is broken and the “L” coil is de-energized.
- This opens the “L” contacts discharging the magnet through resistors R2, R3, and R4.
- Moving the master switch to the drop position or pushing the drop button, closes the contact between terminals “F” and “D”, energizing the “D” coil.
- This closes the “D” contacts and provides reverse voltage to the magnet, through resistors “R1” and “R5”.
- To stop the build up of reverse current, release the master switch control and it will return to the off position, or release the drop push button.
- This breaks the contact between “F” and “D” terminals, de-energizes the “D” coil, opening the “D” contacts, and stops the flow of reverse current through the magnet.

# OHIO MODEL CDS AUTO / MANUAL WIRING DIAGRAMS

## CDS AUTOMATIC CONTROLLER (VARIABLE VOLT)

ASSEMBLY & WIRE DIAGRAM: 018B2634U (0-90; 0-115; 0-230 V-dc)

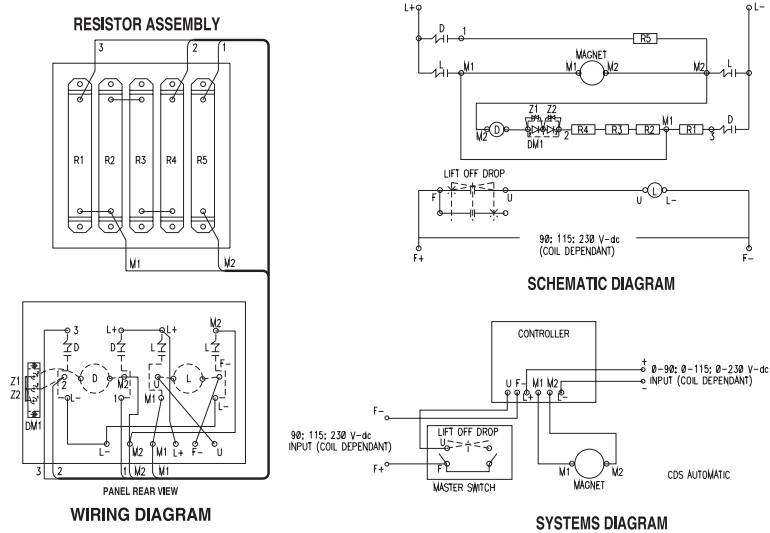

## CDS AUTOMATIC CONTROLLER

ASSEMBLY & WIRE DIAGRAM: 018B2634V (90; 115; 230 V-dc)

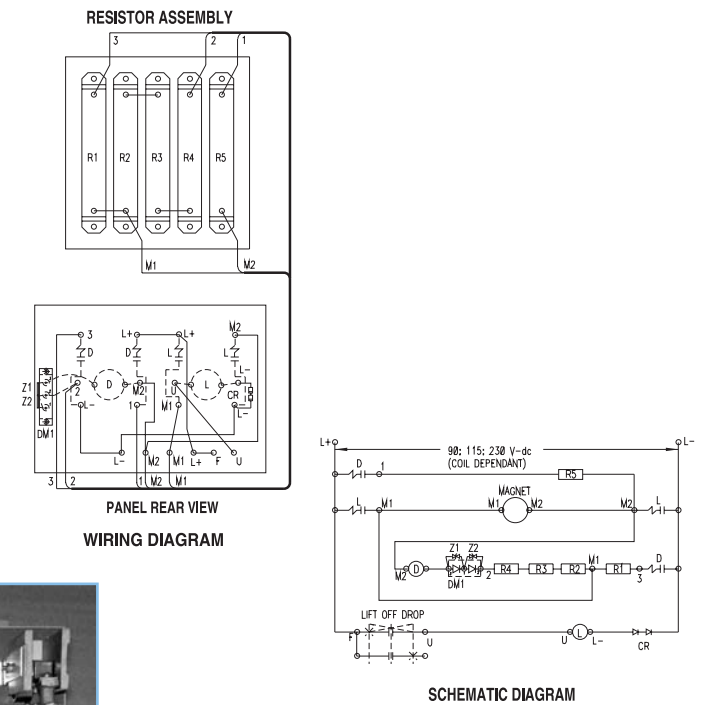

## CDS MANUAL CONTROLLER

ASSEMBLY & WIRE DIAGRAM: 018B2634T (90; 115; 230 V-dc)

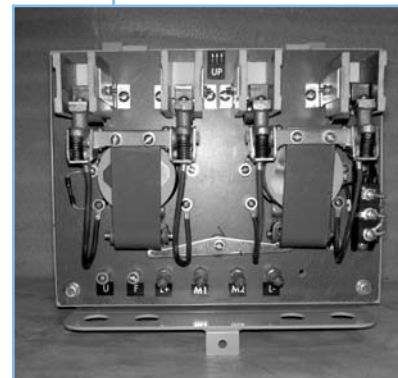
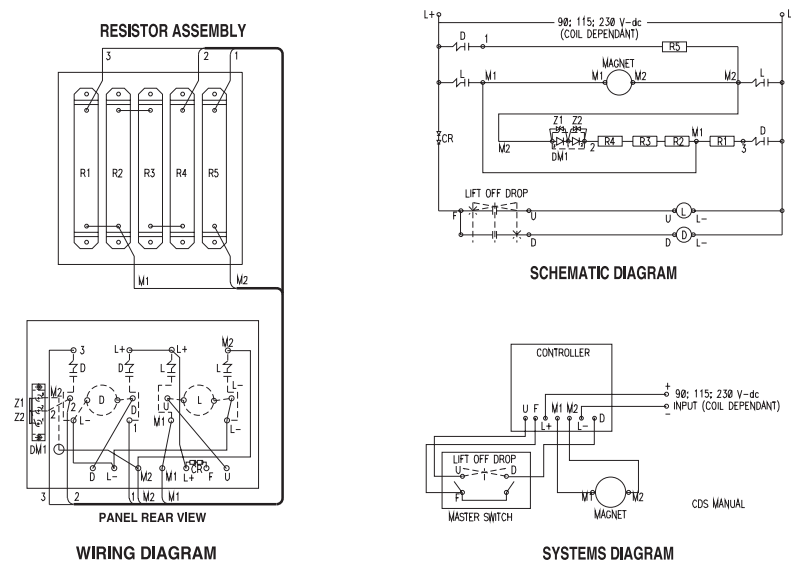
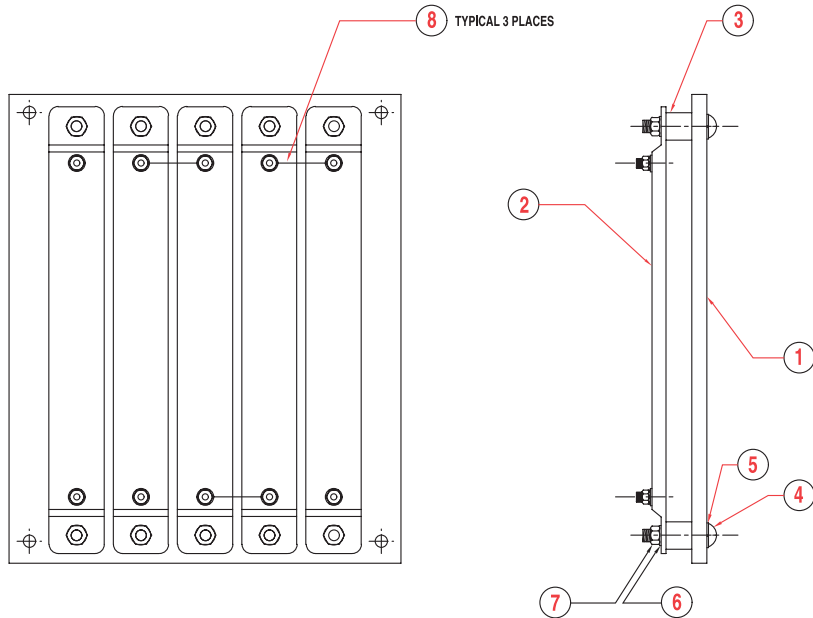

TABLE OF EQUIPMENT		
SYMBOL	DESCRIPTION	FUNCTION
D	REVERSE CONTACT	DROP
L	MAIN CONTACT	LIFT
R1 - R5	RESISTORS	DROP
R2 - R3 - R4	RESISTORS	DISCHARGE

# OM MODEL CDS RESISTOR ASSEMBLY

## RESISTOR ASSEMBLY: CDS 230 V

AUTO & MANUAL WITH DIODE • 018B2632X



NO.	PART NUMBER	QTY	DESCRIPTION
1	018A2630X	1	RESISTOR BOARD
2	018A6208B	5	RESISTOR - 48 Ω
3	018A6102B	10	RESISTOR SPACER: 20 mm
4	A-900025-12	10	SCREW
5	A-900115-05	20	SPLIT LOCKWASHER
6	A-900118-05	20	FLAT WASHER
7	A-900106-05	20	NUT HEX
8	A-950000-102	0.75	WIRE: #14 BARE SOLID COPPER



NO.	PART NUMBER	QTY	DESCRIPTION
1	018A2630X	1	RESISTOR BOARD
2	018A6208B	3	RESISTOR - 48 Ω
3	018A6102B	10	RESISTOR SPACER: 20 mm
4	A-900025-12	10	SCREW
5	A-900115-05	20	SPLIT LOCKWASHER
6	A-900118-05	20	FLAT WASHER
7	A-900106-05	20	NUT HEX
8	A-950000-102	0.75	WIRE: #14 BARE SOLID COPPER
9	A-900241-70	2	RESISTOR - 25.0 Ω - 300 W
10	A-900416-06	4	SCR SL HD PAN HD: M4 X 0.7 X 12 mm
11	A-900116-11	10	INTERNAL TOOTH LOCKWASHER: M4
12	A-900106-38	8	NUT HEX: M4
13	1900B063001	4	RESISTOR MOUNTING BRACKET
14	A-900025-04	4	SCREW

## RESISTOR ASSEMBLY: CDS 115 V

AUTO & MANUAL WITH DIODE • 018B2632F

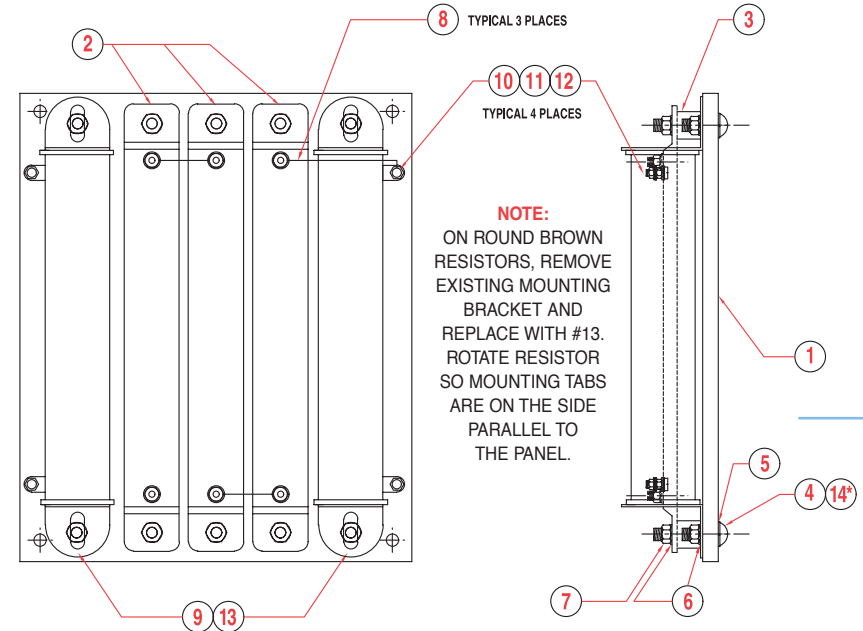

\* USED TO MOUNT OUTSIDE ROUND BROWN RESISTORS ONLY

## MAINTENANCE AND TROUBLE SHOOTING

Check all contact tips for excess wear or burning. Replace if needed.

Check arc shields for burnt areas. Replace any that are badly burned.

Check for burned or damaged insulation on shunts or wires. Replace if found.

Check for carbon tracking on the base panel and insulating parts. If found, remove by filing or scraping. If carbon can not be removed, replace the part.

Check gap 10 mm (0.39 in.) opening between main contacts (#27a and #35e). Adjust by loosening screw (#46) on part (#35c) and turning the assembly.

All pin connections should move easily, and contact springs should provide force when contacts are closed. If springs do not provide contact force, replace them.

Check Power Diode Integrity (DM1) with a standard Digital Volt Meter (DVM), set to the diode check function. (See owner's manual for details.) Disconnect leads to the diode and remove suppressors MOV (Z1 and Z2) to isolate from the circuit. Place the red lead of meter on Terminal 1 of diode (number is stamped next to terminal) and the black lead on Terminal 2. Meter should read < 1.0. Reverse leads and meter should read 1.(00). Repeat for Terminals 3 (red) and 1 (black). If the diode reads bad, replace. Reconnect wires and MOVs (Z1 and Z2).

NOTE: Z1 and Z2 are MOV suppressors to help limit voltage spikes applied to DM1 and causing damage.

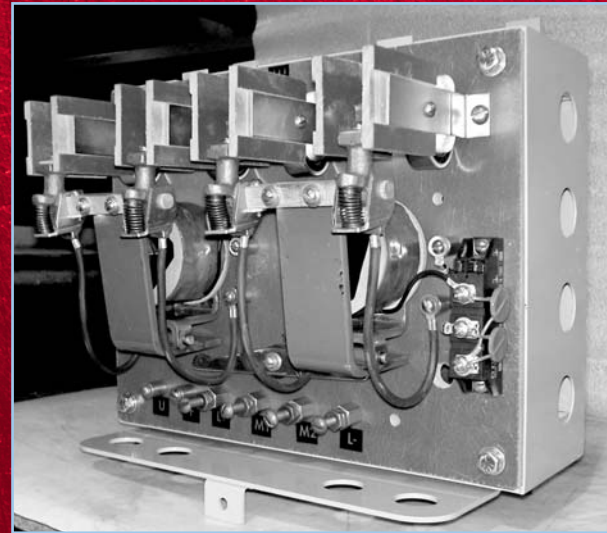

## EMERGENCY SPARE PARTS KITS AND/OR KITS

Automatic ..... #ESP-018M2667A

Manual ..... #ESP-018M2667B

- Contains the parts most likely to fail due to a system problem or a high voltage spike. It is recommended that one of these kits be kept on hand to avoid unnecessary down time.



**OHIO MAGNETICS—PERFORMANCE ENGINEERED**



## OHIO MAGNETICS, INC.

SUBSIDIARY OF **HBD** INDUSTRIES, INC.

5400 Dunham Road • Maple Heights, OH 44137-3687 • 800/486-6446 • Phone: 216/662-8484

Fax: 216/662-9526 • 216/662-2911 • 216/662-3118

Sales

Company

Engineering

E-mail: [sales@ohiomagnetics.com](mailto:sales@ohiomagnetics.com)

Websites: [www.ohiomagnetics.com](http://www.ohiomagnetics.com) • [www.hbdindustries.com](http://www.hbdindustries.com)



*Stearns*