

M91-2-UN2

12/24 VDC, 12 pnp/npn digital inputs, *2 universal inputs, 2 high-speed counter/shaft encoder inputs, 12 transistor outputs, I/O expansion port, RS232/RS485 port

Power supply	12VDC or 24VDC
Permissible range	10.2VDC to 28.8VDC with less than 10% ripple
Maximum current consumption	80mA@24VDC (pnp inputs) 140mA@12VDC (pnp inputs) 170mA (nnp inputs)
Digital inputs	12 pnp (source) or npn (sink) inputs. See Note 1.
Nominal input voltage	12VDC or 24VDC. See Notes 2 and 3.
Input voltages for pnp (source):	
For 12VDC	0-3VDC for Logic '0' 8-15.6VDC for Logic '1'
For 24VDC	0-5VDC for Logic '0' 17-28.8VDC for Logic '1'
Input voltages for npn (sink):	
For 12VDC	8-15.6VDC/<1.2mA for Logic '0' 0-3VDC/>3mA for Logic '1'
For 24VDC	17-28.8VDC/<2mA for Logic '0' 0-5VDC/>6mA for Logic '1'
Input current	4mA@12VDC 8mA@24VDC
Input impedance	3KΩ
Response time (except high-speed inputs)	10mS typical
Galvanic isolation	None
Input cable length	Up to 100 meters, unshielded
High-speed counter	Specifications below apply when inputs are wired for use as a high-speed counter input/shaft encoder. See Notes 4 and 5.
Resolution	16-bit
Input freq.	10kHz max.
Minimum pulse	40μs

Notes:

- All 12 inputs can be set to pnp (source) or npn (sink) via a single jumper and appropriate wiring.
- All 12 inputs can function in 12 VDC or 24 VDC; set via a single jumper and appropriate wiring.
- nnp (sink) inputs use voltage supplied from the controller's power supply.
- Inputs #0 and #2 can each function as either high-speed counter or as part of a shaft encoder. In each case, high-speed input specifications apply. When used as a normal digital input, normal input specifications apply.
- Inputs #1 and #3 can each function as either counter reset, or as a normal digital input; in either case, specifications are those of a normal digital input. These inputs may also be used as part of a shaft encoder. In this case, high-speed input specifications apply.

* Certain inputs can function as normal digital inputs, analog inputs, RTD inputs or thermocouple inputs, in accordance with jumper settings and wiring connections.



Warnings:

- Unused pins should not be connected. Ignoring this directive may damage the controller.
- Improper use of this product may severely damage the controller.
- Refer to the controller's User Guide regarding wiring considerations.
- Before using this product, it is the responsibility of the user to read the product's User Guide and all accompanying documentation.

Power supply, pnp (source) inputs

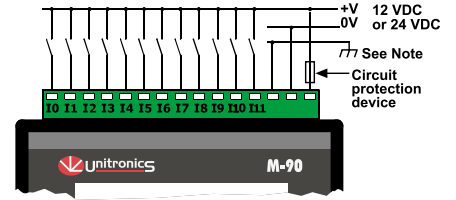

Note:
To avoid electromagnetic interference, mount the controller in a metal panel/cabinet and earth the power supply. Earth the power supply signal to the metal using a wire whose length does not exceed 10cm. If your conditions do not permit this, do not earth the power supply.

nnp (sink) inputs

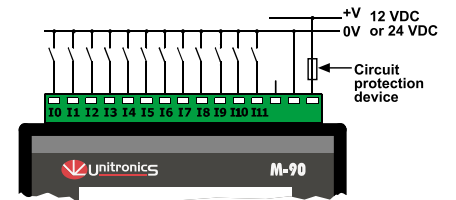

pnp (source) high-speed counter

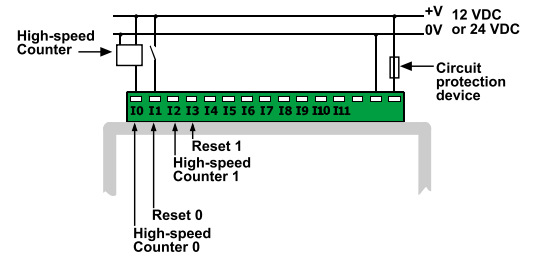

nnp (sink) high-speed counter

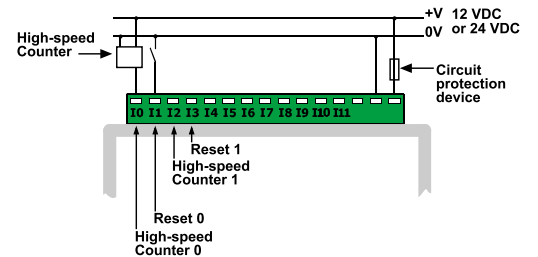

Shaft encoder

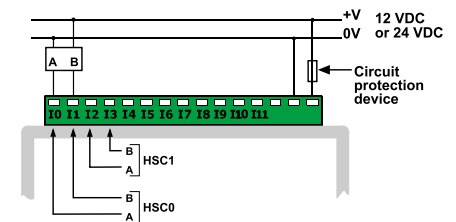

Universal Inputs

Analog Inputs	Two 14-bit, multi-range inputs: 0-10V, 0-20mA, 4-20mA See Note 1
Conversion method	Voltage to Frequency
Input impedance	>400KΩ for voltage 500Ω for current
Isolation	None
Resolution (except 4-20mA)	14-bit (16384 units)
Resolution at 4-20mA	3277 to 16383 (13107 units)
Conversion time	100mSec minimum (according to filter type)
Absolute max. rating	±15V for voltage ±30mA for current
Linearity error	0.04% max. of full scale
Error limit	0.4% of input value
Status indication	Yes, see Note 2

Notes:

1. Input #8 and input #10 can be used as analog inputs, related to signal 0V, in accordance with jumper settings and wiring connections.

2. The analog value can also indicate faults, as shown below:

Value	Possible Cause
-1	Input value deviates slightly below the input range.
16384	Input value deviates slightly above the input range
32767	Input value deviates greatly above or below the input range.

Voltage / Current connection

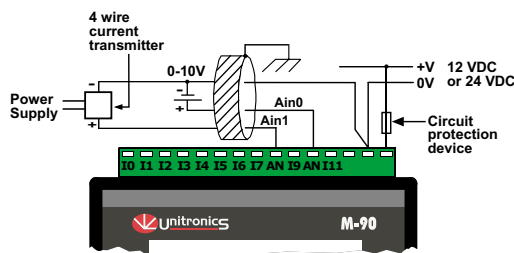

Notes:

- a. Shields should be connected at the signals' source.
- b. The 0V signal of the analog input must be connected to the controller's 0V.

Current connection

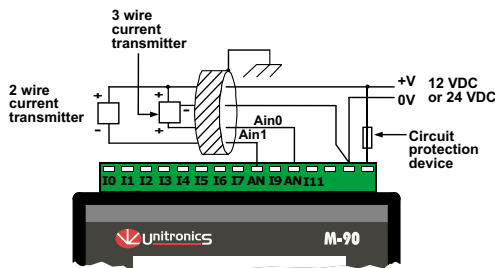

Notes:

- a. Shields should be connected at the signals' source.
- b. The 0V signal of the analog input must be connected to the controller's 0V.

Thermocouple inputs	2 differential inputs. See Note 1.
Input type	Thermocouple
Input ranges	As shown in the table below
Isolation	None
Conversion method	Voltage to Frequency
Resolution	0.1°C / 0.1°F
Conversion time	100mSec minimum (according to filter type)
Input impedance	>10MΩ
Cold junction compensation	local, automatic
Cold junction compensation error	±1.5°C / ±2.7°F maximum
Absolute maximum rating	±0.6 VDC
Linearity error	0.04% max. of full scale
Error limit	0.4% of input value
Status indication	None
Warm-up time	½ hour typically, ±1°C / ±1.8°F repeatability

Notes:

- 1. Thermocouple #0: use Input #10 as positive input & Input #9 as negative input.
Thermocouple #1: use Input #8 as positive input & Input #7 as negative input.
To use inputs as thermocouple, set the relevant jumpers and use appropriate wiring.

Table 1: Input Ranges

Type	Temperature range	Wire color	
		ANSI (USA)	BS 1843 (UK)
mV	-5 to 56mV	-	-
B	200 to 1820°C (300 to 3276°F)	+ Grey - Red	+ None - Blue
E	-200 to 750°C (-328 to 1382°F)	+ Violet - Red	+ Brown - Blue
J	-200 to 760°C (-328 to 1400°F)	+ White - Red	+ Yellow - Blue
K	-200 to 1250°C (-328 to 2282°F)	+ Yellow - Red	+ Brown - Blue
N	-200 to 1300°C (-328 to 2372°F)	+ Orange - Red	+ Orange - Blue
R	0 to 1768°C (32 to 3214°F)	+ Black - Red	+ White - Blue
S	0 to 1768°C (32 to 3214°F)	+ Black - Red	+ White - Blue
T	-200 to 400°C (-328 to 752°F)	+ Blue - Red	+ White - Blue

Thermocouple connection

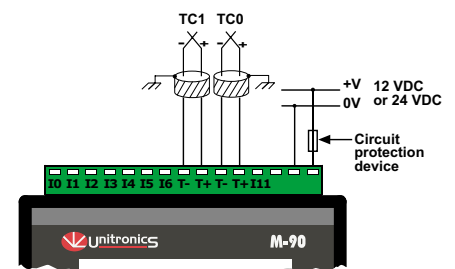

Note:

Shields should be connected at the signals' source.

RTD inputs	Two PT100 inputs. See Note 1.
Input range	-200 to 600°C (-328 to 1100°F) 1 to 320 ohm
Isolation	None
Measurement resolution	0.1°C / 0.1°F
Conversion method	Voltage to Frequency
Conversion time	200mSec minimum (according to filter type)
Input impedance	>10MΩ
Auxiliary current for PT100	150μA typical
Linearity error	0.04% max. of full scale
Error limit	0.4% of input value
Status indication	Yes, see Note 2

Notes:

- PT100 #0: use Input #9 & Input #10, related to CM signal (Input #11).
PT100 #1: use Input #7 & Input #8, related to CM signal (Input #11).
To use inputs as PT100, set the relevant jumpers and use appropriate wiring.

- The analog value can also indicate faults, as shown below:

Value	Possible Cause
32767	Sensor is not connected to input, or value exceeds the permissible range
-32767	Sensor is short-circuited

PT100 connection

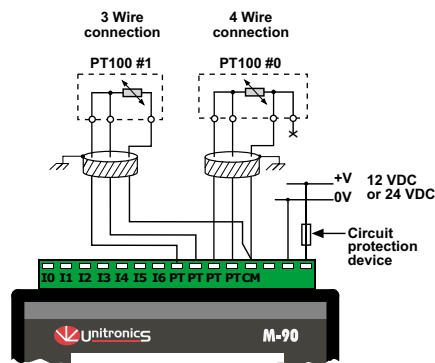

Note:

- Shields should be connected at the signals' source.
- 4 wire PT100 can be used by leaving one of the sense leads unconnected.

Digital outputs	12 pnp (source) outputs 12VDC or 24VDC
Output type	P-MOSFET (open drain)
Isolation	None
Output current	0.5A max. Total current: 3A max.
Max. frequency for normal outputs	50Hz (resistive load) 0.5Hz (inductive load)
High speed output maximum frequency	2kHz (resistive load) See Note 1.
Short circuit protection	Yes
Short indication	by software
On voltage drop	0.5VDC maximum
Power supply for outputs	
Operating voltage	10.2 to 28.8VDC
Nominal operating voltage	12VDC or 24VDC

Note:

- Output #0 and Output #1 may be used as high-speed outputs.

Outputs connection

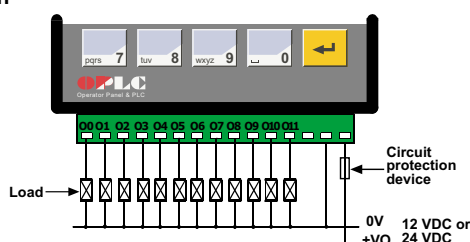

Display	STN, LCD display
Illumination	LED yellow-green backlight
Display size	2 lines, 16 characters long
Character size	5 x 8 matrix, 2.95 x 5.55mm
Keypad	Sealed membrane
Number of keys	15

PLC program	
Ladder Code Memory (virtual)	36K
Memory Bits (coils)	256
Memory Integers (Registers)	256
Timers	64
Execution time	12μsec. for bit operations
Database	1024 integers (indirect access)
HMI displays	80 user-designed displays
HMI variables	64 HMI variables are available to conditionally display and modify text, numbers, dates, times & timer values. The user can also create a list of up to 120 variable text displays, totaling up to 2K.

RS232/RS485 serial port	Used for: <ul style="list-style-type: none"> Application Download/Upload Application Testing (Debug) Connect to GSM or standard telephone modem: <ul style="list-style-type: none"> Send/receive SMS messages Remote access programming RS485 Networking
RS232 (see note)	1 port
Galvanic isolation	None
Voltage limits	±20V
RS485 (see note)	1 port
Input voltage	-7 to +12V differential max.
Cable type	Shielded twisted pair, in compliance with EIA RS485
Galvanic isolation	None
Baud rate	110 – 57600 bps
Nodes	Up to 32

Note:

RS232/RS485 is determined by jumper settings and wiring as described in the document "M91 RS485 Port Settings" packaged with the controller.

I/O expansion port	Up to 96 additional I/Os, including digital & analog I/Os, RTD and more.
Miscellaneous	
Clock (RTC)	Real-time clock functions (Date and Time).
Battery back-up	7 years typical battery back-up for RTC and system data.
Weight	266g (9.37 oz.)
Operational temperature	0 to 50°C (32 to 122°F)
Storage temperature	-20 to 60°C (-4 to 140°F)
Relative Humidity (RH)	5% to 95% (non-condensing)
Mounting method	DIN-rail mounted (IP20/NEMA1) Panel mounted (IP65/NEMA4X)

The tables below show how to set a specific jumper to change the functionality of a specific input. To open the controller and access the jumpers, refer to the directions at the end of these specifications.

Important:

Incompatible jumper settings and wiring connections may severely damage the controller.

JP3, JP4, JP5, JP11, JP12
Input #9 and Input #10 (universal input no. 0)

To use as	JP3 for Input #10	JP4 for Input #10	JP12 for Input #10	JP5 for Input #9	JP11 for Input #9
Normal digital inputs	A	B	B	A	B
Thermocouple input* (See Note 1)	B	A	B	B	B
PT100 input (See Note 2)	B	A	B	B	A
Analog input - voltage (see Note 4)	B	B	A	A See Note 3	B See Note 3
Analog input - current (see Note 4)	B	B	B	A See Note 3	B See Note 3

Notes:

1. Thermocouple input is between Input #10 (T+) and Input #9 (T-).
2. PT100 input is connected to Input #9 and Input #10, related to CM signal (Input #11).
3. When using Input #10 as analog input, Input #9 can be used as normal digital input.
4. Analog inputs are related to signal 0V.

JP2, JP6, JP7, JP10, JP13
Input #7 and Input #8 (universal input no. 1)

To use as	JP6 for Input #8	JP7 for Input #8	JP13 for Input #8	JP2 for Input #7	JP10 for Input #7
Normal digital inputs	A	B	B	A	B
Thermocouple input* (See Note 1)	B	A	B	B	B
PT100 input (See Note 2)	B	A	B	B	A
Analog input - voltage (see Note 4)	B	B	A	A See Note 3	B See Note 3
Analog input - current (see Note 4)	B	B	B	A See Note 3	B See Note 3

Notes:

1. Thermocouple input is between Input #8 (T+) and Input #7 (T-).
2. PT100 input is connected to Input #9 and Input #10, related to CM signal (Input #11).
3. When using Input #8 as analog input, Input #7 can be used as normal digital input.
4. Analog inputs are related to signal 0V.

JP1
Input #11

To use as	JP1
Normal digital input*	A
CM signal for PT100 inputs	B

*Default factory setting

JP8
Input type (for all digital inputs) -
 see Note 1

To use as	JP8
nnp (sink)	A
pnp (source)*	B

Note:

- Inputs #0-6, and #7-11 when these are set as normal digital inputs.

*Default factory setting

JP9
Input voltage (for all digital inputs) -
 see Note 1

To use as	JP9
12VDC	A
24VDC*	B

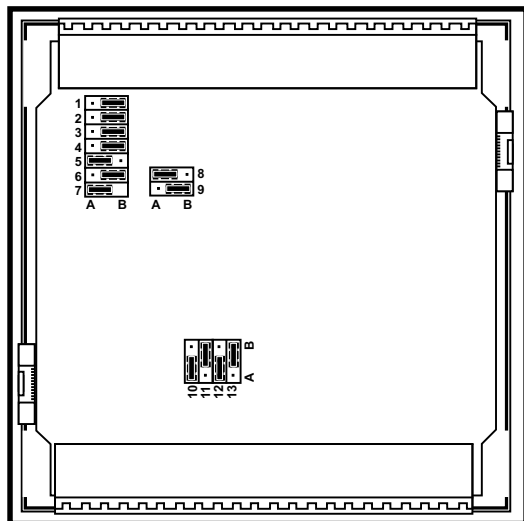

In this figure, the jumper settings will cause the inputs to function as follows:

Universal Input #0 (Input #10): Voltage input, related to 0V

Universal Input #1 (Input #7 and Input #8): PT100 input, related to the CM signal (Input #11)

Input#9: Normal npn, 24VDC digital input

Input#0 to Input #6: npn, 24VDC digital inputs. (Note that these inputs can only function as normal digital inputs.)

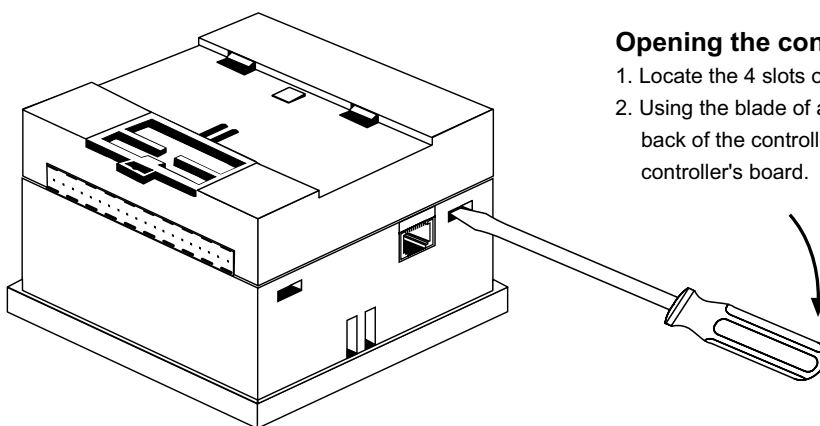

Opening the controller enclosure

1. Locate the 4 slots on the sides of the enclosure
2. Using the blade of a flat-bladed screwdriver, gently pry off the back of the controller as shown in the figure below, exposing the controller's board.

Unitronics reserves the right to revise this publication from time to time and to amend its contents and related hardware and software at any time.

Technical updates (if any) may be included in subsequent editions (if any).

Unitronics product sold hereunder can be used with certain products of other manufacturers at the user's sole responsibility.