

V120-22-R34

Graphic Operator Panel & Programmable Logic Controller

24 VDC, 22 pnp/npn digital inputs, including 2 analog inputs¹ and 3 high-speed counter/shaft encoder inputs, 12 relay outputs, I/O expansion port, 2 RS232/RS485 ports

Power supply	24VDC
Permissible range	20.4VDC to 28.8VDC with less than 10% ripple
Maximum current consumption	290mA@24VDC
Digital inputs	22 pnp (source) or npn (sink) inputs. See Notes 1 and 2
Nominal input voltage	24VDC. See Note 3.
Input voltages for pnp (source):	0-5VDC for Logic '0' 17-28.8VDC for Logic '1'
Input voltages for npn (sink):	17-28.8VDC < 1mA for Logic '0' 0-5VDC > 3mA for Logic '1'
Input current	3.7mA@24VDC
Input impedance	6.5KΩ
Response time (except high-speed inputs)	10mS typical
Galvanic isolation	None
Input cable length	Up to 100 meters, unshielded
High-speed counter	Specifications below apply when inputs are wired for use as a high-speed counter input/shaft encoder. See Notes 4 and 5.
Resolution	32-bit
Input freq.	10kHz max.
Minimum pulse	40µs

pnp (source) high-speed counter

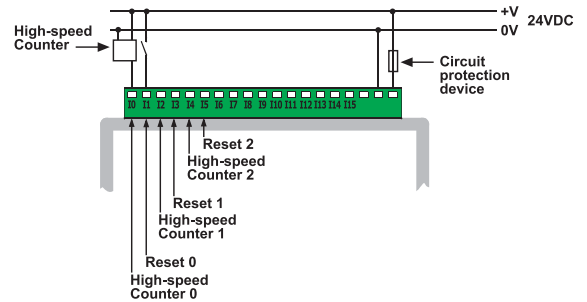

npn (sink) high-speed counter

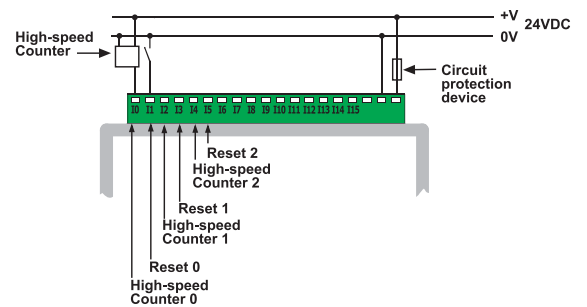

Power supply, pnp (source) inputs

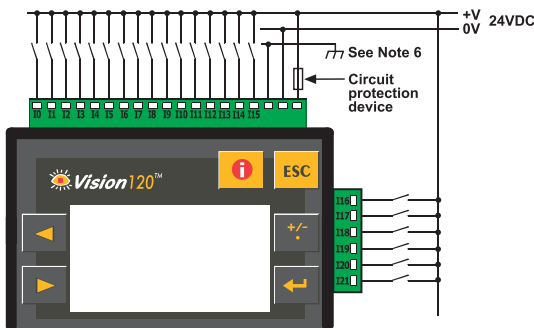

npn (sink) inputs

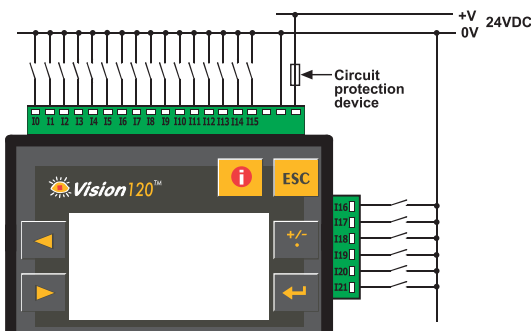

Shaft encoder

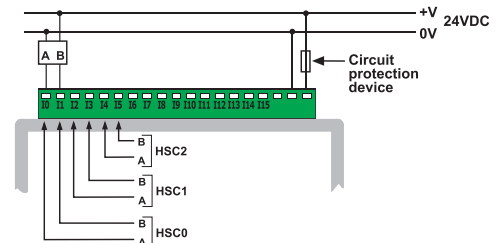

Notes:

1. The total number of inputs is 22. All of these may be used as normal digital inputs. Via jumper settings and wiring, certain of these inputs may be adapted to analog inputs.
2. All 22 inputs can be set to pnp (source) or npn (sink) via a single jumper and appropriate wiring.
3. npn (sink) inputs use voltage supplied from the controller's power supply.
4. Inputs #0, #2 and #4 can each function as either high-speed counter or as part of a shaft encoder. In each case, high-speed input specifications apply. When used as a normal digital input, normal input specifications apply.
5. Inputs #1, #3 and #5 can each function as either counter reset, or as a normal digital input; in either case, specifications are those of a normal digital input. These inputs may also be used as part of a shaft encoder. In this case, high-speed input specifications apply.
6. To avoid electromagnetic interference, mount the controller in a metal panel/cabinet and earth the power supply. Earth the power supply signal to the metal using a wire whose length does not exceed 10cm. If your conditions do not permit this, do not earth the power supply.

Warnings:

- Unused pins should not be connected. Ignoring this directive may damage the controller.
- Improper use of this product may severely damage the controller.
- Refer to the controller's User Guide regarding wiring considerations.
- Before using this product, it is the responsibility of the user to read the product's User Guide and all accompanying documentation.

Analog Inputs	Two 10-bit, multi-range inputs: 0-10V, 0-20mA, 4-20mA See Note 1 on page 1
Conversion method	Successive approximation
Input impedance	>150KΩ for voltage 243Ω for current
Galvanic isolation	None
Resolution (except 4-20mA)	10-bit (1024 units)
Resolution at 4-20mA	204 to 1023 (820 units)
Conversion time	Synchronized to scan time
Absolute max. rating	±15V/30mA
Full scale error	± 2 LSB
Linearity error	± 2 LSB
Status indication	Yes, See Note

Note:
The analog value can also indicate when the input is functioning out of range.
If an analog input deviates above the permissible range, its value will be 1024.

Voltage connection

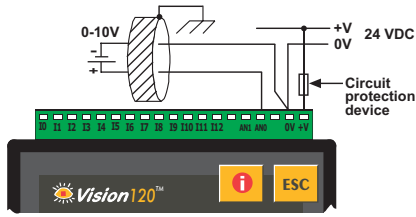

Notes:
a. Shields should be connected at the signals' source.
b. The 0V signal of the analog input must be connected to the controller's 0V.

Current connections

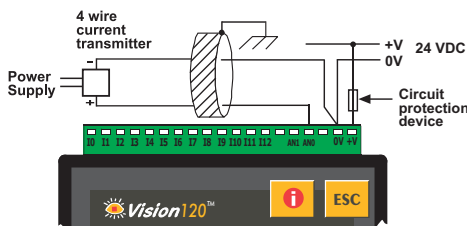
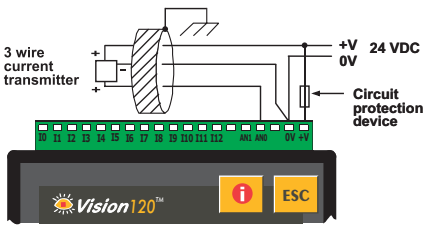
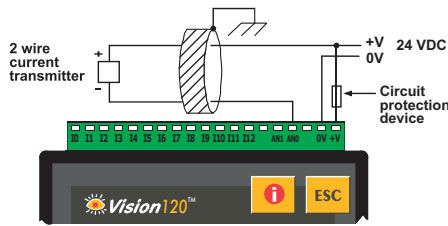

Notes:
a. Shields should be connected at the signals' source.
b. The 0V signal of the analog input must be connected to the controller's 0V.

Relay outputs	12 relay (in 3 groups) See Note
Output type	SPST-NO (Form A)
Type of relay	Tyco PCN-124D3MHZ or compatible
Isolation	by relay
Output current (resistive load)	3A max per output 8A max total for common
Rate voltage	250VAC / 30VDC
Minimum load	1mA@5VDC
Life expectancy	100k operations at maximum load
Response time	10mS (typical)
Contact protection	External precautions required (see below)

Note:
Outputs #0, #1, #2 and #3 share a common signal.
Outputs #4, #5, #6 and #7 share a common signal.
Outputs #8, #9, #10 and #11 share a common signal.

Relay Outputs

- Each Output can be wired separately to either AC or DC as shown below.
- The 0V signal of the relay outputs is isolated from the controller's 0V signal.

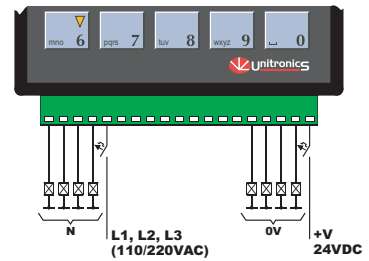

Increasing Contact Life Span

To increase the life span of the relay output contacts and protect the device from potential damage by reverse EMF, connect:

- a clamping diode in parallel to each inductive DC load.
- an RC snubber circuit in parallel with each inductive AC load.

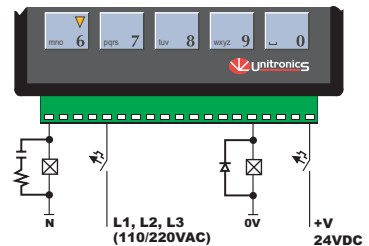

Graphic Display	STN, LCD display
Illumination backlight	LED, yellow-green, software-controlled
Display resolution	128x64 pixels

Keypad	Sealed membrane
Number of keys	16

Program	
Application memory	448K
Memory Bits (coils)	4096
Memory Integers (registers)	2048
Long Integers (32 bit)	256
Double Word (32 bit unsigned)	64
Floats	24
Timers	192
Counters	24
Data Tables	120K (RAM) / 64K (FLASH)
HMI displays	Up to 255
Execution time	0.8µs for bit operations

RS232/RS485 serial ports	Used for: <ul style="list-style-type: none"> • Application Download/Upload • Application Testing (Debug) • Connect to GSM/GPRS or standard telephone modem: <ul style="list-style-type: none"> - Send/receive SMS messages - Remote access programming • RS485 Networking
RS232 (see note)	2 ports
Galvanic isolation	None
Voltage limits	±20V
RS485 (see note)	2 ports
Input voltage	-7 to +12V differential max.
Cable type	Shielded twisted pair, in compliance with EIA RS485
Galvanic isolation	None
Baud rate	110 – 57600 bps
Nodes	Up to 32

Note:
RS232/RS485 is determined by jumper settings and wiring.
Refer to the controller's User Guide regarding communications.

I/O expansion port	Up to 128 additional I/Os, including digital and analog I/Os, temperature and weight inputs and more (number of I/Os may vary according to expansion model)
---------------------------	---

Miscellaneous	
Clock (RTC)	Real-time clock functions (Date and time).
Battery back-up	7 years typical at 25°C, battery back-up for RTC and system data.
Battery	Coin type, 3V lithium battery, CR2450
Weight	310g (10.9 oz.)
Operational temperature	0 to 50°C (32 to 122°F)
Storage temperature	-20 to 60°C (-4 to 140°F)
Relative Humidity (RH)	5% to 95% (non-condensing)
Mounting method	DIN-rail mounted (IP20/NEMA1) Panel mounted (IP65/NEMA4X)

V120-22-R34

I/O Jumper Setting

The tables below show how to set a specific jumper to change the functionality of the controller. To open the controller and access the jumpers, refer to the directions at the end of these specifications.

Important:

Incompatible jumper settings and wiring connections may severely damage the controller.

	Jumper #	NPN	PNP*
Digital Inputs	JP3	A	B

	Jumper #	Voltage	Current	Digital*
Analog 1 / I14	JP1	A	A	B
	JP4	A	B	B
Analog 0 / I15	JP2	A	A	B
	JP5	A	B	B

*Default factory setting

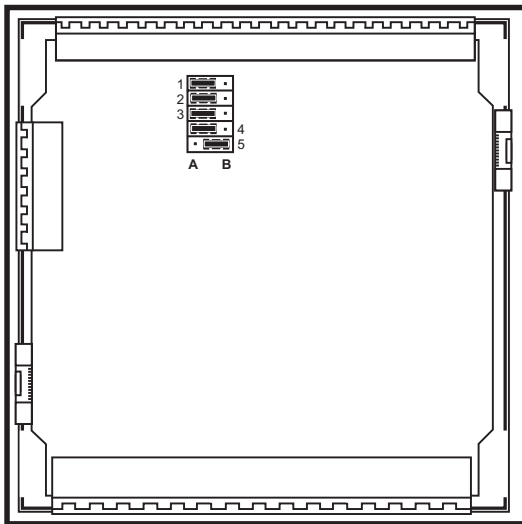

In this figure, the jumper settings will cause the controller to function as follows:

Digital inputs: npn, 24VDC inputs

Analog input 1: Voltage input

Analog input 0: Current input

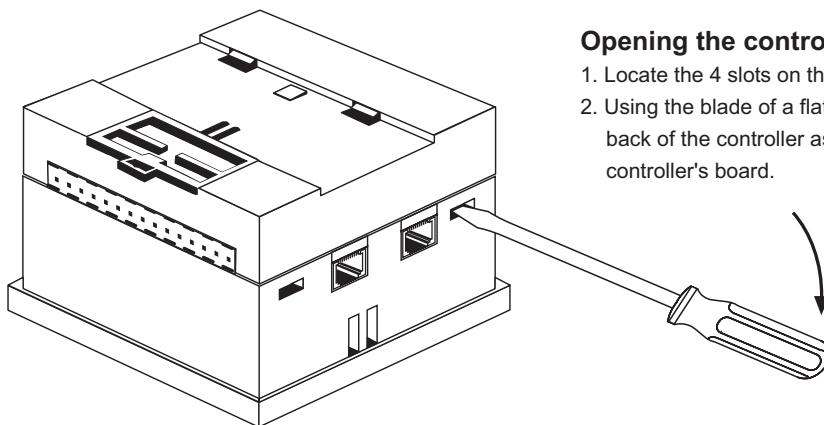

Opening the controller enclosure

1. Locate the 4 slots on the sides of the enclosure
2. Using the blade of a flat-bladed screwdriver, gently pry off the back of the controller as shown in the figure below, exposing the controller's board.

Unitronics reserves the right to revise this publication from time to time and to amend its contents and related hardware and software at any time.

Technical updates (if any) may be included in subsequent editions (if any).

Unitronics product sold hereunder can be used with certain products of other manufacturers at the user's sole responsibility.

