

Drive Contactors

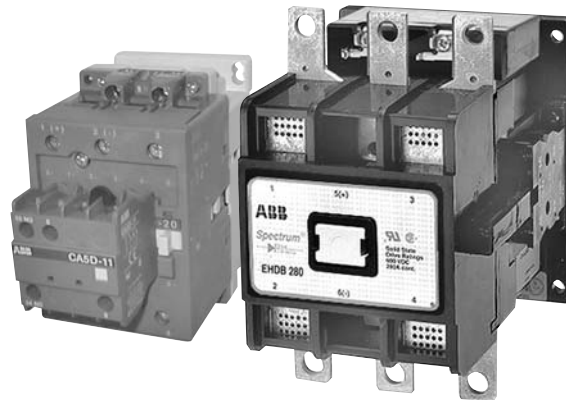

Drive contactors Type DA & EHDB

1



Description Type DA

- 60 amps size
- 500 volt DC ratings
- 160 and 300 volt DC normal closed ratings for dynamic braking
- Low energy auxiliary contacts available (17V, 5mA)
- Mechanically interlocked version available for reversing applications
- Small compact design
- 2 pole (2 N.O.) and 3 pole (2 N.O. & 1 N.C.) available
- Additional auxiliary contact blocks available
- Auxiliary contacts available to meet elevator standards
- Fast, snap-on DIN rail mounting
- Double break contact design
- Captive terminal screws
- Touch-safe design: all connection terminals are protected against accidental touch
- Terminals supplied open for ease of wiring
- Operates over an extended voltage range of 85% to 110% of rated control voltage
- N.C. dynamic braking pole is easily added to two pole contactors
- Screwdriver guide holes
- Snap-on front mounted accessories
- UL and CSA approved

Type EHDB

- 130 amps to 960 amps
- 2 pole (2 N.O.) and 3 pole (2 N.O. & 1 N.C.) power poles available
- 600 VDC making capacity:
300 VDC breaking capacity
- 1 N.O. & 1 N.C. auxiliary contacts are standard and up to six additional auxiliary contacts may be added to provide a total of 8 (4 N.O. & 4 N.C.)
- Early make & late break auxiliary contacts available
- Auxiliary contacts available to meet elevator standards
- EHDB 220, 280 & 360 contactors have withdrawable coils
- Mechanically interlocked contactors available for reversing applications
- Double break contact design with magnetic arc chamber extinguishes arc in shortest possible time
- High temperature encapsulated coil
- Easy removal of arc chute for quick inspection and change of contacts
- Operates over an extended voltage range of 85% to 110% of rated control voltage
- DC control operation available
- UL & CSA approved
UL File # E79416
CSA File # LR19700

Type DA 60 Amps



DA75-21A-11-84

2 & 3 pole — 500 volt N.O. ratings with 160 volt N.C. dynamic braking rating

Thermal amp rating	Maximum amp rating N.C. contact		Auxiliary contacts included		2 pole (2 N.O.)		3 pole (2 N.O. & 1 N.C.)	
	Make 300 VDC	Break 160 VDC	N.O.	N.C.	Catalog number	List price	Catalog number	List price
60	90	55	2 1	1 1	— DA75-20-11-84	— 310	DA75-21-21-84 —	\$ 385 —

3 pole — 500 volt N.O. ratings with 300 volt N.C. dynamic braking rating

Thermal amp rating	Maximum amp rating N.C. contact		Auxiliary contacts included		3 pole (2 N.O. & 1 N.C.)	
	Make 500 VDC	Break 300 VDC	N.O.	N.C.	Catalog number	List price
60	90	55	1	1	DA75-21A-11-84	\$ 430

NOTE: DA75 2 & 3 pole contactors are equipped with polarity-dependent N.O. contacts.

Description

DA drive contactors are specifically designed for use with solid state D.C. adjustable speed drive systems. In drive applications, the contactor is not required to make or break the load during normal operation. The N.C. contact is used for dynamic braking applications.

Coil voltage selection

All DC operated catalog numbers include a 24VDC coil. To select other coil voltages, substitute the code from the Coil Voltage Selection Chart for the two digits after the last dash in the catalog number.

Ex.: A 24V coil is required for an DA75 contactor: DA75-20-11-81

Coil voltage selection chart

Hz	Cntr type	Volts															
		12	24	48	110	120	125	208	220	240	277	380	415	440	480	500	600
60	A		81	83	84	84		34	36	80	42		86	86	51	53	55
50	A		81	83	84					80			85	86			55

NOTE: DC coils are available for DA75 contactors only.
For other voltages, see page 1.26.

Additional auxiliary contacts

Contactor number	Number of auxiliary contacts that may be added to DA contactors
DA75-21-21-84	(1 – 2) CA5 & (1) CAL5 Aux
DA75-20-11-84	(1) DB Adder deck & (2) CA5 & (1) CAL5 Aux

Auxiliary contact block adders

Top mounted for DA9 – DA75	Catalog number	List price
N.O.	CA5-10	\$ 15
N.C.	CA5-01	
1 N.O. & 1 N.C.	CAL5-11	30

All above auxiliary contact blocks fulfill the mirror contacts standards in IEC609 47-1 Annex F, Positive driven action IEC 609 47-1, Chapter 4. They also fulfill elevator standard ASME A17-1-2000.

Type EHDB 130 to 960 Amps

Drive
contactors

1



EHDB280C-1L



EHDB520C2P-1L

2 & 3 pole — 600 volt N.O. ratings with 300 volt N.C. dynamic braking rating

Thermal amp rating 600 volts	Maximum amp rating N.C. contact		Auxiliary contacts included		2 pole (2 N.O.)		3 pole (2 N.O. & 1 N.C.)	
	Make 300 VDC	Break 160 VDC	N.O.	N.C.	Catalog number	List price	Catalog number	List price
130	260	171	1	1	EHDB130C2P-1L	\$ 675	EHDB130C-1L	\$ 863
220	450	285	1	1	EHDB220C2P-1L	698	EHDB220C-1L	998
280	565	363	1	1	EHDB280C2P-1L	945	EHDB280C-1L	1290
380	728	472	1	1	EHDB360C2P-1L	1950	EHDB360C-1L	2820
520	1040	680	1	1	EHDB520C2P-1L	2250	EHDB520C-1L	3375
650	1300	850	1	1	EHDB650C2P-1L	3953	EHDB650C-1L	4650
800	1600	1050	1	1	EHDB800C2P-1L	4845	EHDB800C-1L	5700
960	1920	1250	1	1	EHDB960C2P-1L	6120	EHDB960C-1L	7200

Description

EHDB drive contactors are specifically designed for use with solid state D.C. adjustable speed drive systems. In drive applications, the contactor is not required to make or break the load during normal operation. The N.C. contact is used for dynamic braking applications. EHDB contactors are provided less terminal lugs.

Coil voltage selection

All catalog numbers include a 120V coil. To select other coil voltages, substitute the code from the coil voltage selection chart for the first digit after the dash in the catalog number.

Coil voltage selection chart – EHDB contactors

		Volts														
		24	48	110	120	125	208	220	240	277	380	415	440	480	500	600
60	F G			1		B	2	2	C				3	4		6
50	N			1		J				3	4				6	
DC	Y W P					O			R							

NOTE: For other voltages, consult factory. • 24VAC coils are not available for sizes EHDB520 – EHDB960. • 48VAC coils are not available for sizes EHDB520 – EHDB960. For these 24V and 48V applications, use an interposing control relay. • 12VDC coils are not available for EHDB520 – EHDB960.

DC operated contactors

EHDB130 – EHDB960

DC and AC operated contactors have the same magnet structure except the DC coil includes a resistor and a normally closed late break auxiliary interlock. To order, substitute the code from the coil voltage selection chart and refer to the DC magnet coils chart for the price adder.

DC operated contactors are supplied with 2 N.O. & 1 N.C. auxiliary contacts. One additional 1 N.O. & 1 N.C. auxiliary contact block can be mounted on the left side of the contactor.

DC magnet coils (per contactor)

Contactor size	List price
EHDB130	\$ 210
EHDB220 – EHDB280	255
EHDB360	285
EHDB520	360
EHDB650 – EHDB960	495

Type DA & EHDB, mechanically interlocked 60 to 960 Amps

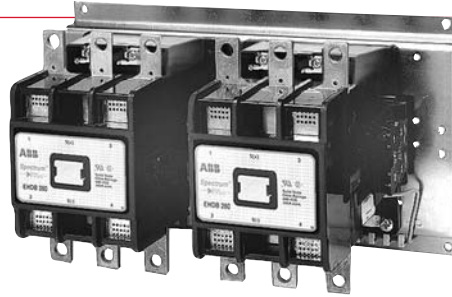

EHDB280M-1L

2 & 3 pole — 600 volt N.O. ratings with 300 volt N.C. dynamic braking rating

Thermal amp rating 500V (DA) 600V (EHDB)	Maximum amp rating N.C. contact		Auxiliary contacts included each contactor		2 pole (2 N.O.)		3 pole (2 N.O. & 1 N.C.)	
	Make	Break	3 Pole N.O.	2 Pole N.C.	Catalog number	List price	Catalog number	List price
60	90	55	1 NO & 1 NC	1 NO & 1 NC	DA75M-20-11-84	\$ 780	DA75M-21A-11-84	\$ 935
130	260	171	1 NO & 1 NC	1 NO & 1 NC	EHDB130M2P-1L	1572	EHDB130M-1L	1947
220	450	285	1 NO & 1 NC	1 NO & 1 NC	EHDB220M2P-1L	1653	EHDB220M-1L	2253
280	565	363	1 NO & 1 NC	1 NO & 1 NC	EHDB280M2P-1L	2148	EHDB280M-1L	2838
380	728	472	1 NO & 1 NC	1 NO & 1 NC	EHDB360M2P-1L	4296	EHDB360M-1L	6036
520	1040	680	1 NO & 1 NC	1 NO & 1 NC	EHDB520M2P-1L	4986	EHDB520M-1L	7236
650	1300	850	1 NO & 1 NC	1 NO & 1 NC	EHDB650M2P-1L	8391	EHDB650M-1L	9786
800	1600	1050	1 NO & 1 NC	1 NO & 1 NC	EHDB800M2P-1L	10,266	EHDB800M-1L	11,976
950	1920	1250	1 NO & 1 NC	1 NO & 1 NC	EHDB960M2P-1L	12,816	EHDB960M-1L	14,976

DA75 contactors are equipped with polarity dependent N.O. contacts. EHDB contactors are equipped with polarity dependent N.C. contacts.

Description

EHDB mechanically interlocked drive contactors are designed for reversing applications. The complete assembly consists of two mechanically and electrically interlocked contactors supplied without control and power wiring. The coil voltage selection

Coil voltage selection

Type DA

All DC operated catalog numbers include a 24VDC coil. To select other coil voltages, substitute the code from the Coil Voltage Selection Chart for the two digits after the last dash in the catalog number.

Ex.: A 24V coil is required for an DA75M contactor: DA75M-20-11-81

Type EHDB

All catalog numbers include a 120V coil. To select other coil voltages, substitute the code from the coil voltage selection chart for the first digit after the dash in the catalog number.

Ex.: A 220V coil is required for an EHDB960M contactor: EHDB960M2P-2L

Coil voltage selection chart – DA contactors

Hz	Cntr type	Volts																
		12	24	48	110	120	125	208	220	240	277	380	415	440	480	500	600	
60	A		81	83	84	84			34	36	80	42		86	86	51	53	55
50	A		81	83	84					80				85	86			55

NOTE: DC coils are available for DA75 contactors only.

For other voltages, see page 1.26.

Coil voltage selection chart – EHDB contactors

	Volts															
	24	48	110	120	125	208	220	240	277	380	415	440	480	500	600	
60	F	G		1		B	2	2	C				3	4		6
50	N		1			J				3	4				6	
DC	Y	W	P		O	R										

NOTE: For other voltages, consult factory. • 24VAC coils are not available for sizes EHDB520 – EHDB960. • 48VAC coils are not available for sizes EHDB520 – EHDB960. For these 24V and 48V applications, use an interposing control relay. • 12VDC coils are not available for EHDB520 – EHDB960.

DC magnet coils (per contactor)

Contactor size	List price
EHDB130M	\$ 390
EHDB220M – EHDB280M	510
EHDB360M	570
EHDB520M	720
EHDB650M – EHDB960M	990

Replacement parts

Drive
contactors

1



EHDBRC280-1

Coils

Contactor size	Catalog number	AC coils list price	DC coils list price
DA75	ZA75-★ ①	\$ 57	\$ 57
EHDB130	EHDBRC130-★	120	150
EHD220, EHD280	EHDR280-★	150	195
EHD350	EHDR360-★	180	240
Withdrawable type			
EHDB220, EHDB280	EHDBRC280-★	150	195
EHDB360	EHDBRC360-★	180	240
EHDB520, EHDB650	EHDBRC650-★	360	450
EHDB800, EHDB960	EHDBRC960-★	435	525

★ Substitute the ★ for a coil voltage suffix found in the Coil Voltage Selection Chart. EHDB coils can be used as replacement parts in EHD contactors.

Coil voltage selection chart – DA contactors ①

Hz	Cntr type	Volts															
		12	24	48	110	120	125	208	220	240	277	380	415	440	480	500	600
60	A		81	83	84	84		34	36	80	42		86	86	51	53	55
50	A		81	83	84			80				85	86			55	

NOTE: DC coils are available for DA75 contactors only.

Coil voltage selection chart – EHDB contactors

	Volts															
	24	48	110	120	125	208	220	240	277	380	415	440	480	500	600	
60	F	G		1		B	2	2	C			3	4		6	
50	N		1			J				3	4			6		
DC	Y	W	P		O		R									

NOTE: For other voltages, consult factory. • 24VAC coils are not available for sizes EHDB520 – EHDB960. • 48VAC coils are not available for sizes EHDB520 – EHDB960. For these 24V and 48V applications, use an interposing control relay. • 12VDC coils are not available for EHDB520 – EHDB960.

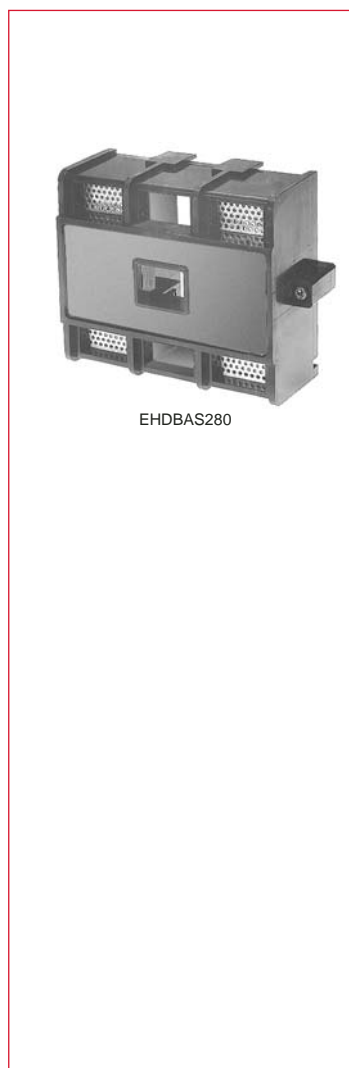

EHDBAS280

Arc shields

Contactor size	Catalog number	List price
3 Pole		
EHDB130	EHDBAS130	\$ 173
EHDB220	EHDBAS220	200
EHDB280	EHDBAS280	233
EHDB360	EHDBAS360	254
EHDB520	EHDBAS520	305
EHDB650	EHDBAS650	350
EHDB800	EHDBAS800	371
EHDB960	EHDBAS960	396
2 Pole		
EHDB130	EHDBAS130-2	165
EHDB220	EHDBAS220-2	192
EHDB280	EHDBAS280-2	221
EHDB360	EHDBAS360-2	242
EHDB520	EHDBAS520-2	293
EHDB650	EHDBAS650-2	338
EHDB800	EHDBAS800-2	357
EHDB960	EHDBAS960-2	383

Auxiliary contact blocks — EHDB130 to EHDB960

Contactor sizes	Description	Terminal markings		Catalog number	List price
		N.O.	N.C.		
EHDB130 to EHDB960	Standard 1 N.O. & 1 N.C.	13, 14	21, 22	CAL16-11A	L \$ 66
	Standard 1 N.O. & 1 N.C.	43, 44	31, 32	CAL16-11B	R 66
	Standard 1 N.O. & 1 N.C.	53, 54	61, 62	CAL16-11C	L 66
	Standard 1 N.O. & 1 N.C.	83, 84	71, 72	CAL16-11D	R 66
	Late break 1 N.O. & 1 N.C.	47, 48	35, 36	CAL16-11E	L,R 75

EHDB130 to EHDB960 contactors are provided with a 1 N.O. & 1 N.C. auxiliary contact block mounted on each contactor. One additional 1 N.O. & 1 N.C. auxiliary contact block can be mounted on the left side of the contactor and two additional 1 N.O. & 1 N.C. contact blocks can be mounted on the right side.

Positive driven action auxiliary contact blocks — EHDB130 to EHDB360

Contactor sizes	Description	Terminal markings		Catalog number	List price
		N.O.	N.C.		
EHDB130	Standard 1 N.O. & 1 N.C. (left side)	13, 14	21, 22	CAL16-11L	\$ 120
	Standard 1 N.O. & 1 N.C. (right side)	43, 44	31, 32	CAL16-11M	
EHDB220 to EHDB360	Standard 1 N.O. & 1 N.C. (left side)	13, 14	21, 22	CAL16-11N	\$ 120
	Standard 1 N.O. & 1 N.C. (right side)	43, 44	31, 32	CAL16-11P	

Only one of these auxiliary contact blocks can be mounted on each side of the contactor. They fulfill the mirror contacts IEC609 47-1 Annex F, positive driven action IEC609 47-1, Chapter 4. They also fulfill elevator standard ASME A17-1-2000.

① For other voltages, see page 1.26.

Replacement parts



EHDBCK280-2



EHDBCK280-NC

Contact kits

Contact kit	Contact size	Catalog number	List price
2 Pole, N.O.			
	DA75	ZL75	\$ 158
	EHDB130	EHDBCK130-2	233
	EHDB220	EHDBCK220-2	300
	EHDB280	EHDBCK280-2	360
	EHDB360	EHDBCK360-2	698
	EHDB520	EHDBCK520-2	1026
	EHDB650	EHDBCK650-2	1368
	EHDB800	EHDBCK800-2	1688
	EHDB960	EHDBCK960-2	2115

N.C. DB Kit only

Contact size	Contact rating	Auxiliary interlocks	Catalog number	List price
DA75	55A/160V; 28A/300V	1 NO	CA5D-11	\$ 60
DA75	300V	—	CA5D-01	75
EHDB130	300V	—	EHDBCK130-NC	143
EHDB220	300V	—	EHDBCK220-NC	165
EHDB280	300V	—	EHDBCK280-NC	165
EHDB360	300V	—	EHDBCK360-NC	315
EHDB520	300V	—	EHDBCK520-NC	513
EHDB650	300V	—	EHDBCK650-NC	513
EHDB800	300V	—	EHDBCK800-NC	690
EHDB960	300V	—	EHDBCK960-NC	690

Lug kits

Contact size	Wire size	Catalog number	List price
2 & 3 Pole			
EHDB130	8-3/0	EHTK110	\$ 20
EHDB220 – EHDB280	6-250	EHTK210	45
EHDB360 – EHDB650	4-500	EHTK550N	75
EHDB800	(2) 4-500	EHTK700	100
EHDB960	(3) 2-600	EHTK800	225

Technical data

Type DA

Drive
contactors

1

Contactor		DA75-21	DA75-21A
Main poles			
N.O. Poles, Amps @ 500VDC	A	60	60
240 VDC	HP	15	15
500 VDC	HP	30	30
Center pole			
N.C. Pole, 160V Make	Max. Amps	90	—
N.C. Pole, 160V Break	Max. Amps	55	—
N.C. Pole, 300V Make	Max. Amps	—	90
N.C. Pole, 300V Break	Max. Amps	—	55
DC rating			
Maximum thermal current	A	60	60
Peak interrupting current	A	90	90
Connectable wire size			
Main poles with lugs		8 – 1	8 – 1
Auxiliary contacts, min/max		18 – 10	18 – 10
Main contacts (contactor life)			
Mechanical endurance @ no load	mil.	5	5
Electrical endurance, main poles	mil.	1.5	1.5
Frequency of operations	per hour	600	600
Auxiliary contacts			
NEMA rating		A600	A600
AC rated voltage	V	600	600
AC thermal rated current	A	10	10
AC maximum making	VA	7200	7200
AC maximum breaking	VA	720	720
NEMA rating		P600	P600
DC rated voltage	V	600	600
DC thermal rated current	A	5	5
DC maximum make-break	A	0.2	0.2
Min. breakdown AC RMS voltage between live parts and ground	V	2200	2200
Minimum permissible load, 17V	A	0.005	0.005
Max. wire size on terminals @ 2/term		10 AWG	10 AWG
Max. operations per hour		600	600
Min. expected mechanical life	mil.	10	10
Min. expected electrical life	mil.	2	2
Coil operating data			
AC power consumption			
Inrush 60 Hz	VA	200	200
Holding 60 Hz	VA	20	20
Holding 60 Hz	W	5.5	5.5
AC operating time (in milliseconds)			
Closing time	ms	20 – 25	20 – 15
Opening time	ms	10 – 15	10 – 15
General data			
Approximate weight	lbs	2.4	2.4
Temperature limits			
Maximum operating temperature	°C	50	50
Minimum operating temperature	°C	-25	-25
Minimum storage temperature	°C	-40	-40
Maximum storage temperature	°C	70	70
Min. breakdown AC RMS voltage	V	2200	2200
Operating altitude			
Maximum operating altitude	feet	10,000	10,000

Technical data Type EHDB

Contactor model number		EHDB130	EHDB220	EHDB280	EHDB360	EHDB520	EHDB650	EHDB800	EHDB960
N.O. poles, Amps	600 VDC	150	220	280	360	520	650	800	960
N.C. pole, 600V Make	Max. amps	260	456	565	728	1040	1300	1600	1920
N.C. pole, 300V Break	Max. amps	171	285	363	472	680	850	1050	1250
Connectable wire size									
Main poles with lugs		8 – 30	8 – 30	5 – 250 kcmils	4 – 500 kcmils	(2) 4 – 500 kcmils	(2) 4 – 500 kcmils	(3) 2 – 600 kcmils	(3) 2 – 600 kcmils
Auxiliary contacts	min./max.	16/10	16/10	16/10	16/10	16/10	16/10	16/10	16/10
DC rating information									
	No. Poles								
Peak interrupting current	A	195	330	420	540	780	975	1200	1440
Maximum thermal current	A	130	220	280	360	520	650	800	960
Main contacts (contactor life)									
Mechanical endurance @ no load	mil.	5	5	5	5	5	5	5	5
Electrical endurance	mil.	1.5	1.5	1.5	1.5	1.5	1.5	1.5	1.5
Frequency of operations	per hour	300	300	300	300	300	300	300	300
Auxiliary contacts									
NEMA rating		A600	A600	A600	A600	A600	A600	A600	A600
AC rated voltage	V	600	600	600	600	600	600	600	600
AC thermal rated current	A	10	10	10	10	10	10	10	10
AC maximum making	VA	7200	7200	7200	7200	7200	7200	7200	7200
AC maximum breaking	VA	720	720	720	720	720	720	720	720
NEMA rating									
DC rated voltage	V	600	600	600	600	600	600	600	600
DC thermal rated current	A	5	5	5	5	5	5	5	5
DC maximum make-break	A	0.2	0.2	0.2	0.2	0.2	0.2	0.2	0.2
Min. breakdown AC RMS voltage									
between live parts and ground		2200	2200	2200	2200	2200	2200	2200	2200
Min. permissible load, 17V	A	0.005	0.005	0.005	0.005	0.005	0.005	0.005	0.005
Expected mechanical life	mil.	5	5	5	5	5	5	5	5
Max. operations per hour		300	300	300	300	300	300	300	300
Coil operating data									
AC power consumption									
Inrush 60 Hz	VA	490	900	900	1200	2900	2900	400	4000
Holding 60 Hz	VA	35	52	52	65	105	105	140	140
Holding 60 Hz	W	11	18	18	22	44	44	60	60
DC power consumption									
Inrush	W	330	500	500	630	800	800	1100	1100
Holding	W	22	3.6	3.6	4	20	20	20	20
AC operating time									
Closing time	ms	20 – 30	20 – 30	20 – 30	20 – 30	30 – 50	30 – 50	30 – 50	30 – 50
Opening time	ms	7 – 15	7 – 15	7 – 15	7 – 15	10 – 20	10 – 20	10 – 20	10 – 20
DC operating time									
Closing time	ms	20 – 30	30 – 40	30 – 40	30 – 40	60 – 80	60 – 80	60 – 80	60 – 80
Opening time	ms	17 – 27	27 – 37	27 – 37	27 – 37	10 – 20	55 – 75	55 – 75	55 – 75
General data									
Approximate weight	lbs	5	9.2	9.2	13	27.3	27.3	37	38
Temperature limits									
Maximum operating temperature	°C	70	70	70	70	70	70	70	70
Minimum operating temperature	°C	-40	-40	-40	-40	-40	-40	-40	-40
Minimum storage temperature	°C	-50	-50	-50	-50	-50	-50	-50	-50
Maximum storage temperature	°C	70	70	70	70	70	70	70	70
Min. Breakdown AC RMS Voltage		2200	2200	2200	2200	2200	2200	2200	2200
Operating altitude									
Maximum operating altitude	feet	10,000	10,000	10,000	10,000	10,000	10,000	10,000	10,000

Approximate dimensions Type DA, 2 & 3 pole

DA75

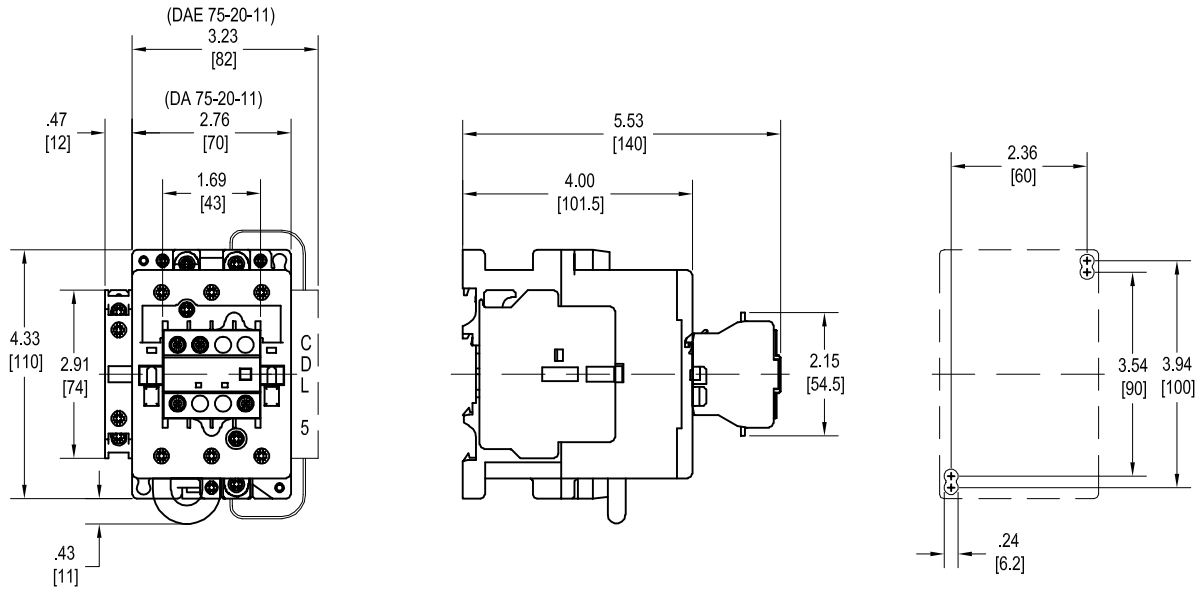

DA75M

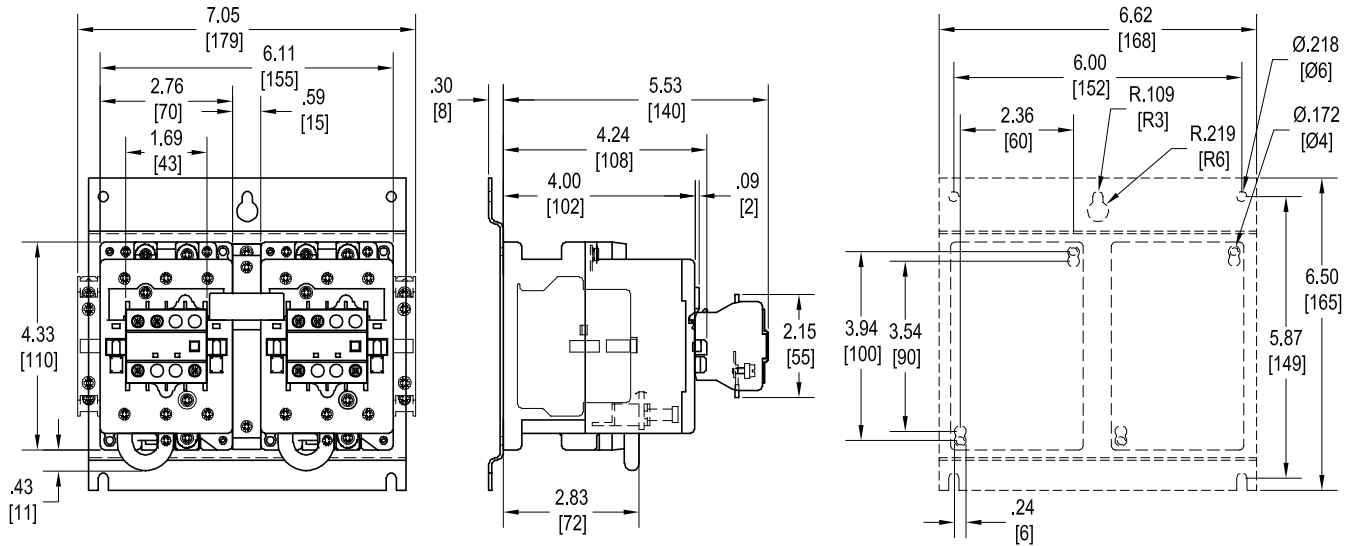

Approximate dimensions Type EHDB 2 & 3 pole; Mounting positions

EHDB130 – EHDB960

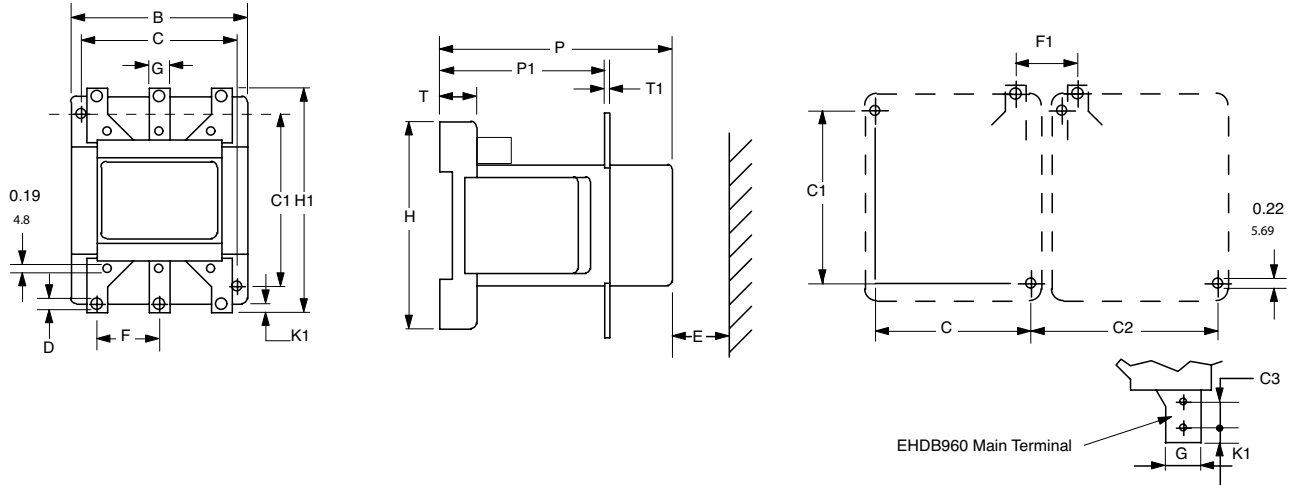

DIM.	B			B2	C	C1	C2				E	D	F	G	H	H1	K1	P	P1	T	T1	C3	
	1, 2	3	4				①	②	③	④													
	Aux. contact block																						
EHDB130in	4.88	5.31	5.75	5.94	4.33	4.72	5.00	5.00	5.35	5.79	1.57	0.43	1.61	0.79	5.51	6.73	0.39	5.63	3.58	0.75	0.16	—	
mm	124	135	146	151	110	120	127	127	136	147	40	11	41	20	140	171	10	143	91	19	4	—	
EHDB220in	5.35	5.83	6.30	6.46	4.72	5.51	5.39	5.39	5.87	6.34	0.59	0.24	1.77	0.79	6.14	7.79	0.39	6.65	4.06	0.41	0.20	—	
mm	136	148	160	164	120	140	137	137	149	161	15	6	45	20	156	198	10	169	103	10.5	5	—	
EHDB280in	5.35	5.83	6.30	6.46	4.72	5.51	5.39	5.39	5.87	6.34	0.59	0.24	1.77	0.79	6.14	7.79	0.39	6.65	4.06	0.41	0.20	—	
mm	136	148	160	164	120	140	137	137	149	161	15	6	45	20	156	198	10	169	103	10.5	5	—	
EHDB360in	6.92	7.44	7.72	8.11	6.30	5.51	7.20	7.32	7.48	7.76	1.18	0.24	2.44	0.98	6.14	8.14	0.49	6.88	4.21	0.7 ^⑤	0.20	—	
mm	176	189	196	206	160	140	183	186	190	197	30	6	62	25	156	207	12.5	175	107	19 ^⑤	5	—	
EHDB520in	7.80	8.23	8.62	8.90	6.69	7.87	7.91	7.91	8.19	8.54	1.57	0.24	2.64	0.98	8.78	10.71	0.49	8.90	5.51	0.9 ^⑤	0.24	—	
mm	198	209	219	226	170	200	201	201	208	217	40	6	67	25	223	272	12.5	226	140	23 ^⑤	6	—	
EHDB650in	7.80	8.23	8.62	8.90	6.69	7.87	7.91	7.91	8.19	8.54	1.57	0.24	2.64	0.98	8.78	10.71	0.49	8.90	5.51	0.9 ^⑤	0.24	—	
mm	198	209	219	226	170	200	201	201	208	217	40	6	67	25	223	272	12.5	226	140	23 ^⑤	6	—	
EHDB800in	9.61	9.96	10.31	10.63	8.66	7.87	9.69	9.69	10.00	10.35	1.57	0.24	3.23	1.57	8.78	11.57	0.79	8.90	5.51	0.9 ^⑤	0.24	—	
mm	244	253	262	270	220	200	246	246	254	263	40	6	82	40	223	294	20	226	140	23 ^⑤	6	—	
EHDB960in	9.61	9.96	10.31	10.63	8.66	7.87	9.69	9.69	10.00	10.35	1.57	0.24	3.23	1.57	8.78	11.57	0.79	8.90	5.51	0.9 ^⑤	0.24	1.36	
mm	244	253	262	270	220	200	246	246	254	263	40	6	82	40	223	294	20	226	140	23 ^⑤	6	34.5	

- ① Minimum dimension
 - ② Makes distance F1 = F
 - ③ Includes space for three auxiliary contact blocks between the contactors.
 - ④ Includes space for four auxiliary contact blocks between the contactors.
 - ⑤ Damping elements are included.
- NOTE: Screw, nut and washer are included for terminal hardware.

Type DA & EHDB mounting positions

