

Welding isolation Contactors



Welding isolation contactors

1



Applications

ABB welding isolation contactors are suited to the rugged demands set forth by the automotive industry and are specifically designed for use in high current welding applications. ABB is the leading contactor supplier for automotive welding applications.

Features

- Includes sizes:
 - W3 thru W6 in 3 pole configurations
 - W4 thru W5 in 2 pole configurations
 - Unique contact design assures reliable and safe operation during high current welding cycles
 - 1 N.O. & 1 N.C. auxiliary contacts are standard and up to 6 additional auxiliary contacts may be added to provide a total of 8 (4 N.O. & 4 N.C.)
 - Easy front removal of arc chute for quick inspection and change of contacts
 - Operates over an extended voltage range of 85% to 110% of rated control voltage
 - UL Listed, File # E79416
 - CSA Certified, File # LR19700
- AW welding isolation contactors can save substantial space compared to other conventional contactors.

140A – 600A



A110W



A300W



AF460W

3-Pole, A.C.

Size	Amp rating	Catalog number	List price
W3	140	A110W-30-11-84	\$ 480
—	200	A145W-30-11-84	825
W4	250	A185W-30-11-84	1290
—	300	A210W-30-11-84	1635
W5	350	A260W-30-11-84	1815
—	400	A300W-30-11-84	1875
W6	600	AF460W-30-11-70	4425

2-Pole, A.C.

Size	Amp rating	Catalog number	List price
W3	140	—	—
—	200	A145W-20-11-84	\$ 750
W4	250	A185W-20-11-84	1180
—	300	A210W-20-11-84	1500
W5	350	A260W-20-11-84	1675
—	400	A300W-20-11-84	1750
W6	600	—	—

Coil voltage selection – wide range AC/DC coils for
AF contactors

All AC operated catalog numbers include a 100-250 V AC/DC coil. To select other coil voltages, substitute the code from the Coil Voltage Selection Chart for the two digits after the last dash in the catalog number.

Ex.: A 24V coil is required for a AF460W contactor: AF460W-30-11-68

Coil voltage selection – A contactors

All AC operated catalog numbers include a 120VAC coil. To select other coil voltages, substitute the code from the Coil Voltage Selection Chart for the two digits after the last dash in the catalog number.

Ex.: A 240V coil is required for an A75 contactor: A75-30-11-80

Auxiliary contact blocks

For additional auxiliary contact blocks, see catalog number explanation on page 1.2. Add \$ 20 to list price for each additional auxiliary, and see page 1.18 for available combinations.

Vertical connection bars between 2 pole
contactor and MCCB – two bars

MCCB	For contactor	Catalog number	List price
S3, S4	A145W-20 – A185W-20	BEA185-20D/S3S4	\$ 50
S3,S4	A210W-20 – A300W-20	BEA210-20D/S4	55
S5	A210W-20 – A300W-20	BEA300-20D/S5	60

For other accessories, see page 1.16 to 1.35.

Coil voltage selection chart – A contactors

Hz	Cntr type	Volts															
		12	24	48	110	120	125	208	220	240	277	380	415	440	480	500	600
60	A		81	83	84	84		34	36	80	42		86	86	51	53	55
50	A		81	83	84				80				85	86			55

For other voltages, see page 1.26.

Coil voltage selection – AF50 to AF750

AC/DC VOLTS, 40 - 60 HZ			
24 - 60 DC	20 - 60 DC	48 - 130 AC/DC	100 - 250 AC/DC
68 ①	72 ②	69	70

① AF400 – AF750, DC only.

② AF50 – AF300, DC only.

Technical data

Welding
contactors

1

Frame size	A110W	A145W	A185W	A210W	A260W	A300W	AF460W
Amp rating, 50°C	140	200	250	300	350	400	600
Making capacity, 600 VAC	1320	1740	2220	2520	3120	3360	4550
Breaking capacity, 480 VAC	880	1160	1480	1680	2080	2240	4180
Withstand current							
RMS	2500	2700	2900	3200	3600	4100	5800
Peak	3500	3900	4100	4600	5200	5900	8816
Short time current							
1 second	1320	1800	2000	2500	3100	3500	4600
10 seconds	800	1200	1500	1700	2100	2400	4400
30 seconds	500	800	1000	1200	1300	1500	3100
1 minute	350	600	800	1000	1000	1100	2500
15 minute	175	280	320	400	450	500	840
Coil operating data							
A.C. power consumption							
Inrush 60 Hz, VA	450	600	600	1350	1350	1350	800
Holding 60 Hz, VA	27	40	40	65	65	65	40
Holding 60 Hz, W	8	12	12	19	19	19	4.5
Maximum short circuit ratings							
MCCB							
kA @ 480VAC	85	85	85	85	85	85	84
kA @ 600VAC	35	35	35	35	35	35	42
Class J fuses	200	200	200	200	200	200	–

Approximate dimensions A110W – A300W

00.00 Inches
00.00 [Millimeters]

A110W

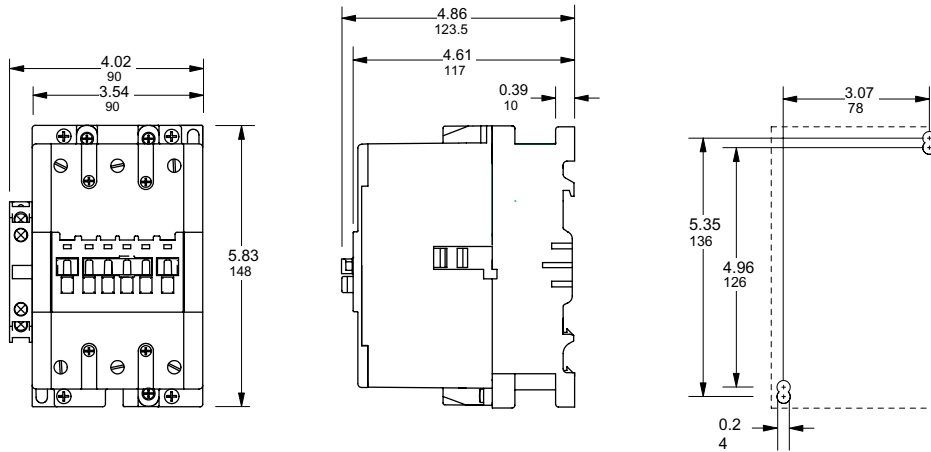

A145W, A185W

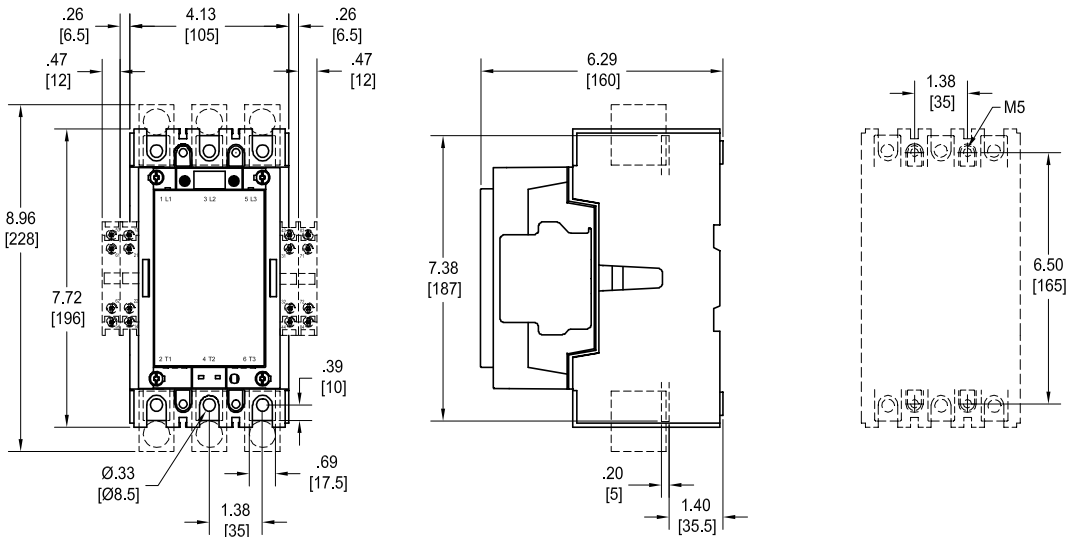

A210W, A260W, A300W

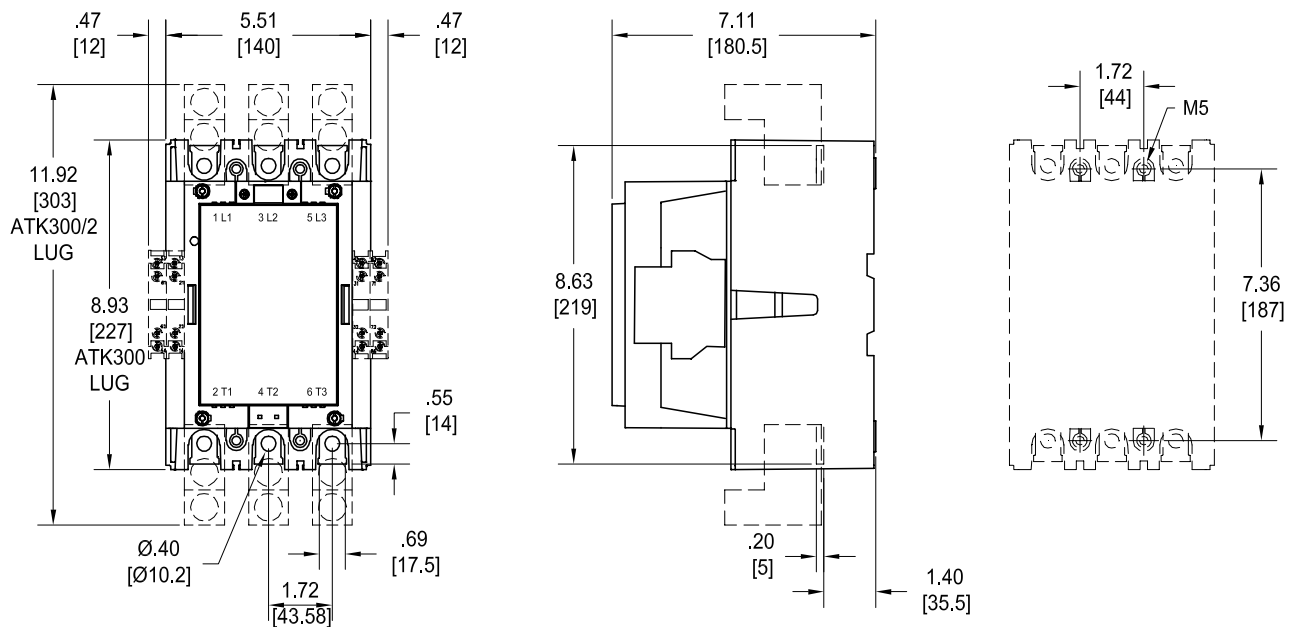

Approximate dimensions AF460W

Welding
contactors

1

00.00 Inches
00.00 [Millimeters]

AF460W

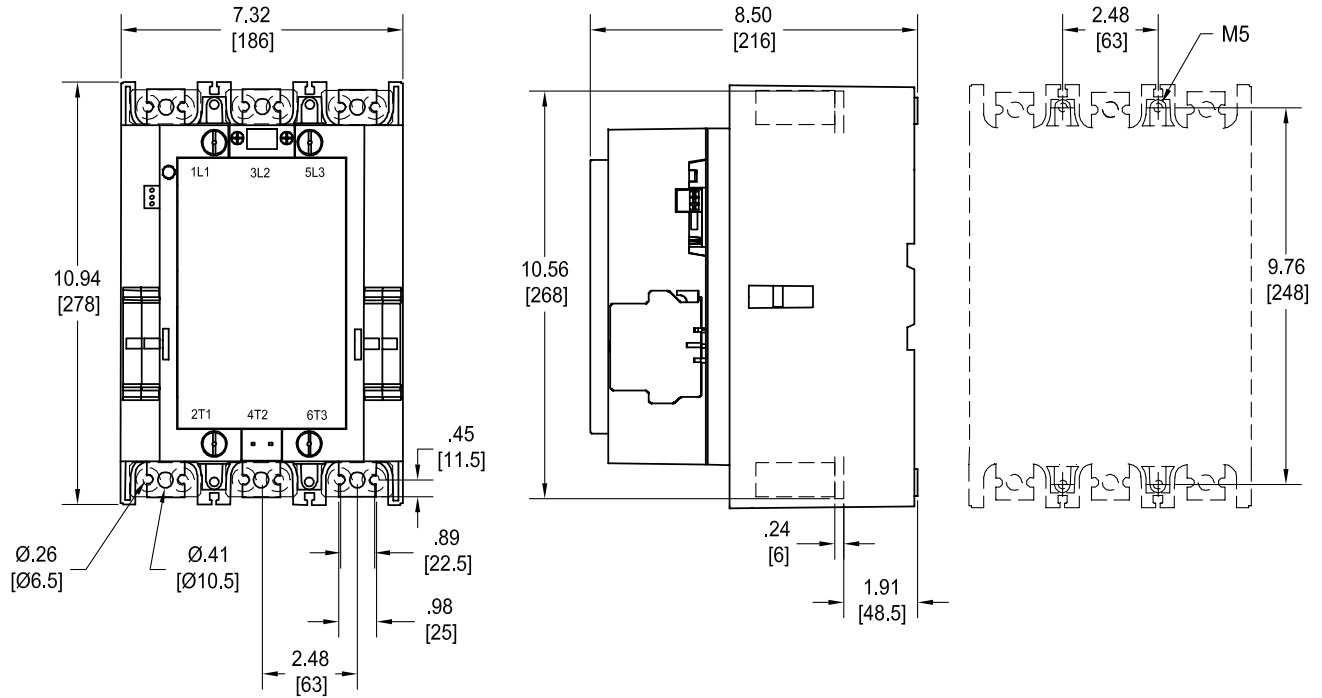

Notes