

DATA SHEET

5600 Solid State Control Relays

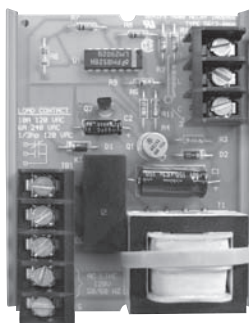

PRINCIPLE OF OPERATION

The 5600 Relays were developed especially for use as safe, reliable components for commercial and industrial products. Designed to operate from electrodes or probes contacting conductive liquids, they are ideally suited to level control applications in products like vending, dispensing and ice-making machines, water softeners, dishwashers, coffee makers; plus many types of operating equipment in the food, drug, dairy, brewing, distilling and chemical processing industries.

These relays have a low energy sensing circuit with a lock-in holding feature that permits operation over a range of levels, or from momentary contact pilot devices such as float, flow, pressure and limit switches, thermostats and pushbutton actuators. They are equally suitable for use as original equipment components in many products and systems that require monitoring and control of such process variables as temperature, pressure, humidity, flow, voltage and current.

Other Features and Advantages

- Choice of direct or inverse operation to provide fail-save control.
- UL Recognized Component File No. E 67365.
- In direct operation, load relay is energized when the low voltage dc sensing circuit is completed. In inverse operation, load relay is de-energized when the low voltage dc sensing circuit is completed.

NOTE: When ordering, please specify Type 5611 relays for direct operation applications, and Type 5612 relays for inverse operation.

- All line voltage circuits are isolated from the low voltage dc sensing circuit to assure optimum safety in service.
- Low voltage dc sensing circuit also permits location of relays several thousand feet from electrodes or remote pilot devices.
- Relays will operate reliably when mounted in any position required to meet a complete range of application design requirements.
- Barrier-type terminal blocks with saddle clamp screw terminals for 12 to 18 gauge wire are standard. Quick-disconnect tabs or other wiring terminals can also be supplied to meet specific application requirements.
- Load contacts are covered with a clear plastic housing to protect against dust and moisture to assure reliable long-life operation.

Installation Notes

Because the 5600 Relay features a low voltage, low current sensing circuit, inexpensive small gauge lead wires may be used between relays and electrodes, sensors, or pilot switching devices. Shielded cables are not required, and lead wires do not have to be isolated from other wiring. Also, in many level control applications, a common electrode is not required so long as a good, dependable metallic ground return from the relay to the liquid is provided.

5600 Special Purpose Relay Catalog Numbers

Part Number	Relay Description	Relay Voltage
56110000	Direct Operation	120 VAC
56111000	Direct Operation	240 VAC
56112000	Direct Operation	12 VDC
56113000	Direct Operation	24 VDC
56114000	Direct Operation	24 VAC
56120000	Inverse Operation	120 VAC
56121000	Inverse Operation	240 VAC
56122000	Inverse Operation	12 VDC
56123000	Inverse Operation	24 VDC
56124000	Inverse Operation	24 VAC

Dimensions

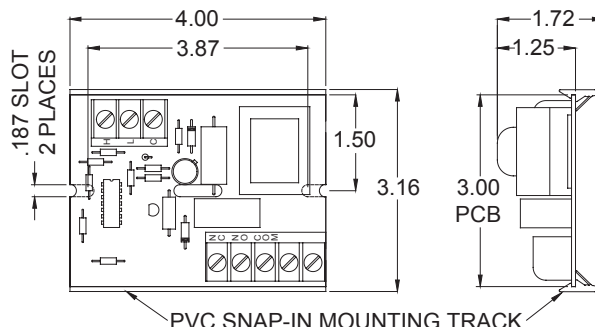

Specifications

Input Voltage	120 VAC 50/60 Hz 240 VAC 50/60 Hz 24 VAC 50/60 Hz 12 VDC 24 VDC
Power Consumption	4 Volt-Amperes, 2 watt Max.
Contact Rating	10 amperes resistive load at 120 VAC 1/3 HP at 120 VAC 6 amperes resistive load 240 VAC 6 amperes resistive load at 28 VDC
Output Contact Arrangement	Single pole, double throw Gold-flashed silver cadmium oxide
Ambient Temperatures	-40° F to 150° F -40° C to 65.5° C
Sensing Circuit	17.5 volts DC open circuit, 400 micro-amperes short circuit. Includes a lock-in feature for greater versatility
Sensitivity	50,000 ohms fixed is standard, other sensitivities, fixed or adjustable, are available on special order.

Typical Applications

The diagrams illustrate basic details of typical applications in which 5600 Relays are used as original equipment components to provide fail-safe control by de-energizing the load in the event of power or relay failure.

Diagram A - A Type 5611 Relay is used for direct operation to provide automatic pump down control for dehumidifiers, sumps or any other product requiring control of a liquid at a given high level set point.

Diagram B - A Type 5612 Relay is used for inverse operation to provide pump-up control for carbonators, humidifiers, purification stills, etc. where liquid must be kept above a low level set point.

Diagram C - A Type 5611 Relay is used for direct operation to provide low level alarm and/or cut-off with lock-in and manual reset for automatic dispensing, bottling and mixing machines.

Diagram D - A Type 5611 Relay is used for direct operation with a transducer or any other pilot device to perform specific control functions required by many commercial and industrial products.

Typical Application Diagrams

DIAGRAM A
PUMP DOWN CONTROL
5600-11
DIRECT OPERATION

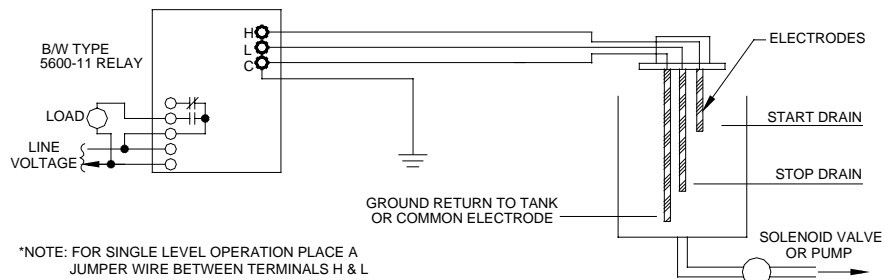

DIAGRAM B
PUMP UP CONTROL
5600-12
INVERSE OPERATION

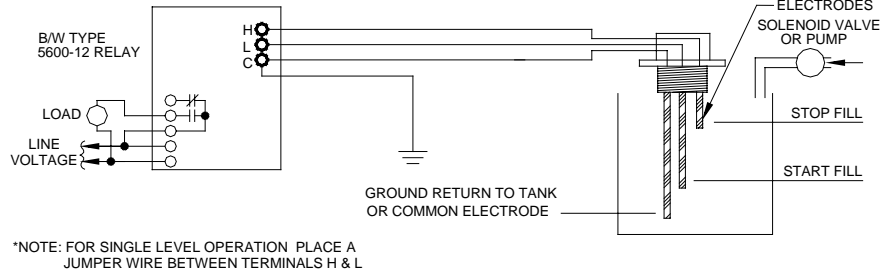

DIAGRAM C
LOW LEVEL ALARM
OR CUT OFF
5600-11
DIRECT OPERATION
WITH LOCK-IN &
RESET PUSHBUTTON

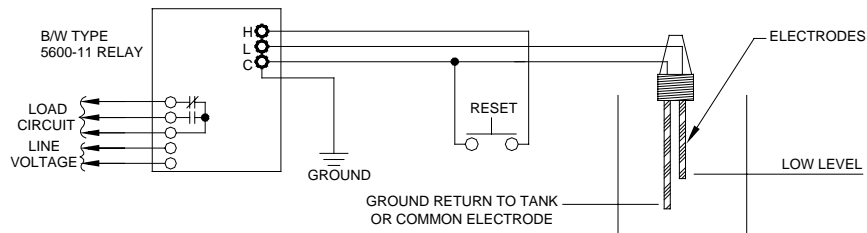

DIAGRAM D
CONTROL FROM
RESISTIVE TRANSDUCER
5600-11
DIRECT OPERATION
LOAD ACTUATION ON
DECREASING RESISTANCE

