

## HYDROPNEUMATIC TANK PANELS

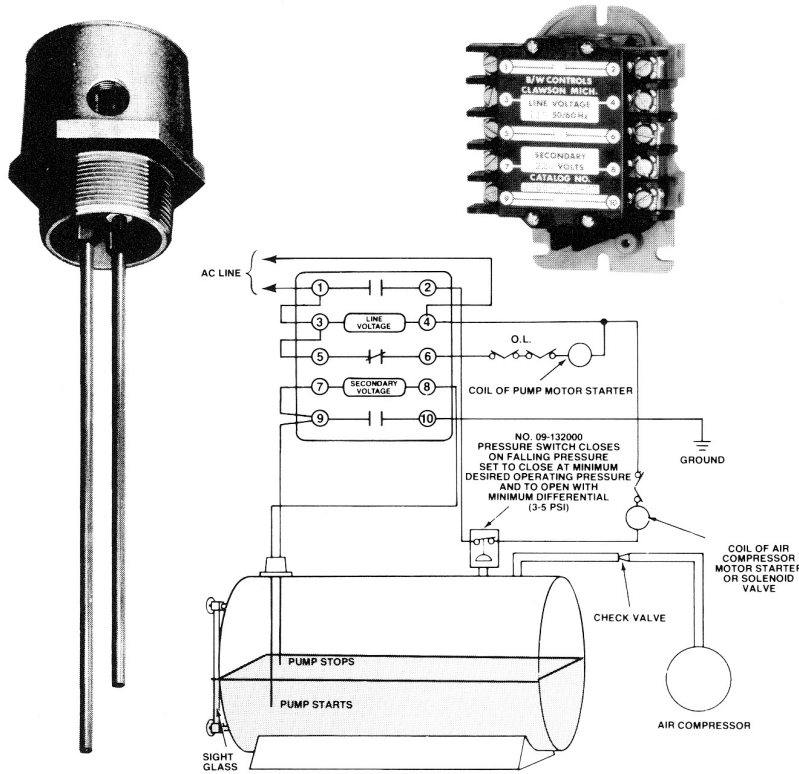

Typical Single Pump Add-Air Type Hydropneumatic Tank Control consists of a Type 1500-G relay and two electrodes of proper type and length supported by a cast pressure tight electrode holder.

BIW hydropneumatic tank control systems provide simple, positive means of maintaining a properly balanced relationship between the water level and air pressure in house tanks for large and small buildings, subdivision water supplies, and other installations that require reliable, trouble-free operation. Fully automatic on start up, it requires little or no maintenance and minimizes short pump cycling during high demand periods.

### PRINCIPLE OF OPERATION

As shown at left, the basic single pump add air system consists of BIW Type 1500-G pump control relay which operates from electrodes installed in the tank to start the pump at a low water level and stop the pumping cycle when the water reaches a given high level. The addition of air into the tank is controlled by a pressure switch and is permitted only when the pump is idle. Thus required air is automatically supplied to the tank whenever pressure drops below the desired lower operating pressure and only enough is added to maintain this pressure until the water level falls below the lower electrode and the pump is started again. When the pump starts, the air supply compressor, or solenoid valve, is locked out and the rising water then gradually compresses the air until the desired upper operating pressure is reached. This occurs when the water level has been pumped up to the upper electrode.

The operating pressure differential of the system is determined by the distance between the pump start and pump stop electrodes instead of by the pressure switch differential, it is essential that electrode lengths be properly established to maintain desired air and water balance at all times.

### STANDARD ALTERNATOR CONTROL Panel Model 8040-AU2I

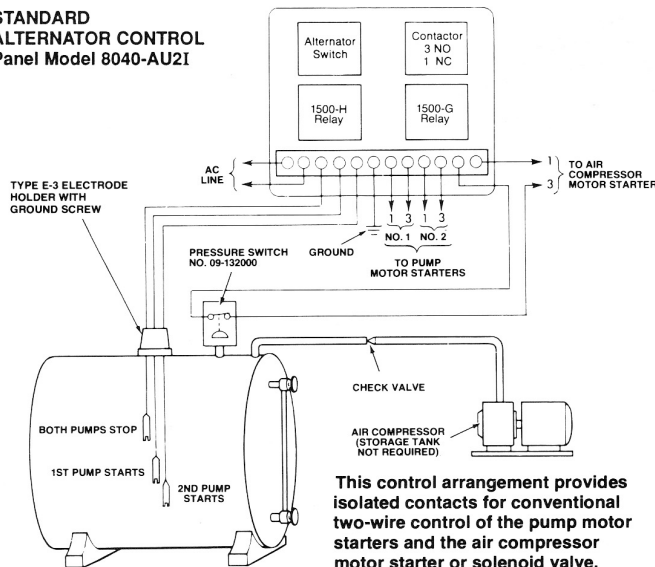

This control arrangement provides isolated two-wire control for conventional two-wire control of the pump motor starters and the air compressor motor starter or solenoid valve. It is suitable for use with up to Size 5 combination starters.

### STANDARD COMBINATION MOTOR STARTER Control Panel Model 8040-H-C1B

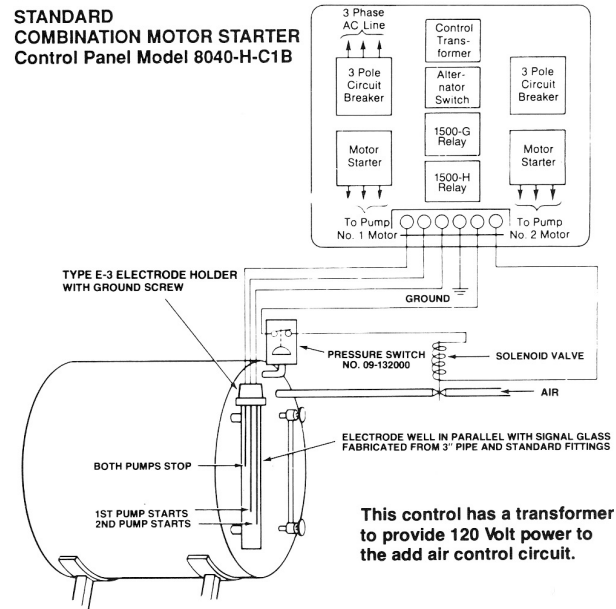

This control has a transformer to provide 120 Volt power to the add air control circuit.

## HYDROPNEUMATIC TANK PANELS

### ELECTRODE EQUIPMENT

For details on electrode holders see Catalog Section 6012, and for electrode information see Section 6013.

Solid rod electrodes are generally used for applications requiring relatively short lengths of six feet or less to reach desired operating levels. If longer lengths are necessary — or if space limitations prevent installation of rod electrodes, Type E-1P or Type E-1S shielded wire suspension electrodes should be used.

**Installation** — Electrode holders should be mounted vertically — either through the top of the tank, with electrodes extending downward to the desired operating levels, or in an external chamber installed on the end of the tank as illustrated below.

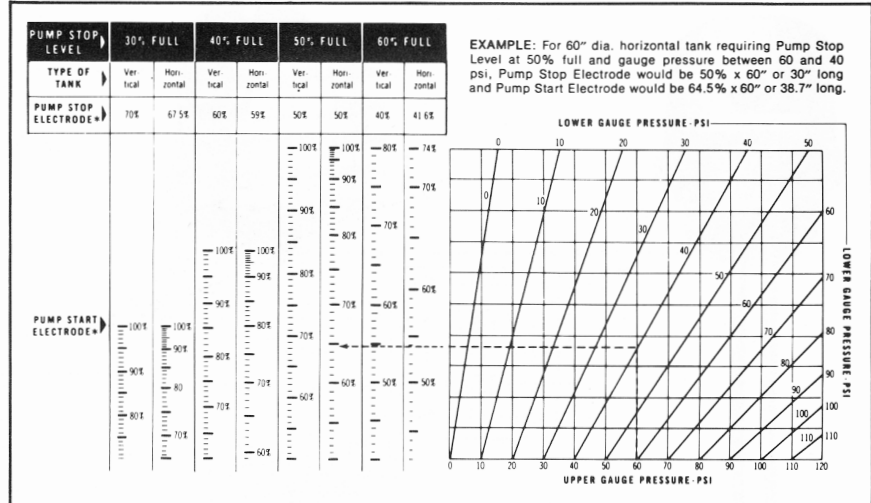
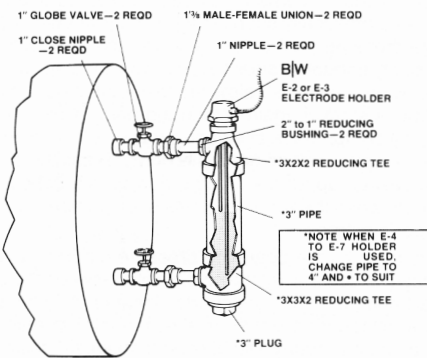

\*All electrode lengths are given in per cent of height for Vertical Tanks and per cent of diameter for Horizontal Tanks. Percentage values shown assume electrode holder will be mounted in top of tank.

### HOW TO DETERMINE ELECTRODE LENGTHS

**Pump STOP Electrode** — Select desired Pump Stop Level from the per cent full values listed at top of chart AND NOTE THE PERCENT FACTOR GIVEN FOR Pump STOP Electrode for the type of tank to be controlled. Multiply this percent factor by height or diameter of tank to obtain length of Pump STOP Electrode.

**Pump START Electrode** — Select desired operating pressure range. Then, starting at

the Upper Gauge Pressure listed on the horizontal scale, draw a vertical line up to intersect the diagonal line shown for desired Lower Gauge Pressure. From this point, draw a horizontal line left to the vertical scale in the column used to determine the Pump STOP Electrode length. Multiply the percent factor shown on scale by the height or diameter of tank to obtain length of Pump START Electrode.

### ADD AIR CONTROL

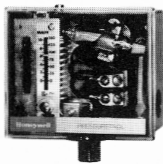

BIW Part No. 09132000  
Range 10-150 psi  
8.0 Amp @ 115 VAC  
5.1 Amp @ 230 VAC

The switch contacts close on falling pressure and must be set to close at the system lower operating pressure. The differential is fixed at approximately 4 psi, so that the addition of air serves only to maintain the system lower pressure. If any other type of pressure switch is used, the operating reset differential must be set to no more than 5 psi.

### DISCHARGE AIR CONTROL



BIW Part No. 09132100  
Range 10-140 psi  
8.0 Amp @ 115 VAC  
5.1 Amp @ 230 VAC

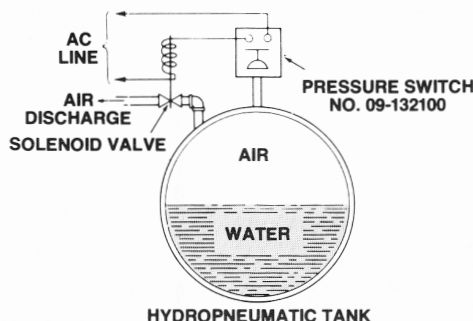

The discharge air control arrangement shown at the left may be added to any basic BIW system, however, it is only required when excess air enters the system from sources such as deep well pumps.

The switch contacts close on rising pressure and should be set about 10 psi above the system upper operating pressure. The reset differential is fixed at approximately 5 psi.