

## Warranty, Service & Repair

To register your product with the manufacturer, go to the Flowline website for on-line registration. The website address is as follows:

[www.flowline.com](http://www.flowline.com)

On-line Warranty Registration can be found under Contact Flowline on the Navigation Bar along the side of the home page.

If for some reason your product must be returned for factory service, go to the Flowline website listed above. Online Factory Service can be found under Contact Flowline on the Navigation Bar along the side of the home page. Click on **Return Authorization** to begin the registration process. You will need the following information at the time of registration:

1. Part Number and full Serial Number from product
2. Name and telephone number of someone who can answer technical questions related to the product and its application.
3. Return Shipping Address
4. Brief Description of the Symptom
5. Brief Description of the Application

Once you have received a Material Return Authorization number, ship the product prepaid in its original packing to:

Flowline Factory Service  
MRA \_\_\_\_\_  
10500 Humbolt Street  
Los Alamitos, CA 90720

To avoid delays in processing your repair, write the MRA on the shipping label. Please include the information about the malfunction with your product. This information enables our service technicians to process your repair order as quickly as possible.

# FLOWLINE®

## Vertical Buoyancy Level Switch LV10 Series Owner's Manual



Version 3.2A

© 2007 FLOWLINE Inc.

All rights reserved.

Manual # LV900001-LV10-09/07-M3-2

## WARRANTY

Flowline warrants to the original purchaser of its products that such products will be free from defects in material and workmanship under normal use and service for a period which is equal to the shorter of one year from the date of purchase of such products or two years from the date of manufacture of such products.

This warranty covers only those components of the products which are non-moving and not subject to normal wear. Moreover, products which are modified or altered, and electrical cables which are cut to length during installation are not covered by this warranty.

Flowline's obligation under this warranty is solely and exclusively limited to the repair or replacement, at Flowline's option, of the products (or components thereof) which Flowline's examination proves to its satisfaction to be defective. FLOWLINE SHALL HAVE NO OBLIGATION FOR CONSEQUENTIAL DAMAGES TO PERSONAL OR REAL PROPERTY, OR FOR INJURY TO ANY PERSON.

This warranty does not apply to products which have been subject to electrical or chemical damage due to improper use, accident, negligence, abuse or misuse. Abuse shall be assumed when indicated by electrical damage to relays, reed switches or other components. The warranty does not apply to products which are damaged during shipment back to Flowline's factory or designated service center or are returned without the original casing on the products. Moreover, this warranty becomes immediately null and void if anyone other than service personnel authorized by Flowline attempts to repair the defective products.

Products which are thought to be defective must be shipped prepaid and insured to Flowline's factory or a designated service center (the identity and address of which will be provided upon request) within 30 days of the discovery of the defect. Such defective products must be accompanied by proof of the date of purchase.

Flowline further reserves the right to unilaterally waive this warranty and to dispose of any product returned to Flowline where:

- a. There is evidence of a potentially hazardous material present with product.
- b. The product has remained unclaimed at Flowline for longer than 30 days after dutifully requesting disposition of the product.

THERE ARE NO WARRANTIES WHICH EXTEND BEYOND THE DESCRIPTION ON THE FACE OF THIS WARRANTY. This warranty and the obligations and liabilities of Flowline under it are exclusive and instead of, and the original purchaser hereby waives, all other remedies, warranties, guarantees or liabilities, express or implied. EXCLUDED FROM THIS WARRANTY IS THE IMPLIED WARRANTY OF FITNESS OF THE PRODUCTS FOR A PARTICULAR PURPOSE OR USE AND THE IMPLIED WARRANTY OF MERCHANTABILITY OF THE PRODUCTS.

This warranty may not be extended, altered or varied except by a written instrument signed by a duly-authorized officer of Flowline, Inc.

# SPECIFICATIONS

## Step One

Accuracy:  $\pm 2$  mm in water  
 Repeatability:  $\pm 1$  mm in water  
 Extreme orientation:  $\pm 20^\circ$  from vertical  
 Specific gravity: .8 minimum  
 Switch type:   
   -3\_1: Dry contact, SPDT  
   -2\_1: Dry contact, SPST  
 Switch voltage:   
   -3\_1: 120 VAC, 120 VDC @ 15 VA  
   -2\_1: 120 VAC, 120 VDC @ 50 VA  
 CE rating: 30 Wrms and 42.4 Vpeak or 60 VDC @ 15 VA  
 Switch output: Selectable NO or NC states  
 Temperature range: F:  $-40^\circ$  to  $176^\circ$ (C:  $-40^\circ$  to  $80^\circ$ )  
 Pressure range: 25 psi (2 bar) @  $25^\circ\text{C}$ ., derated @ 1.667 psi (.113 bar) per  $^\circ\text{C}$ . above  $25^\circ\text{C}$ .  
 Probe material: Polypropylene (PP)  
   Polyvinylidene Fluoride (PVDF)  
 Probe rating: NEMA 6 / IP68  
 Mounting threads: 3/4" NPT (3/4" BSP)  
 Cable type: 10 ft. (3 m), 3-wire, 22 gauge with ground, shield & PP or PFA jacket  
 CE compliance: EN 61326 EMC  
   EN 61010-1 safety

## Technology

The vertical buoyancy switch and the vertical float switch both consist of a float, magnet, reed switch and baffle body which dampens turbulence and eliminates the negative effects of switch chatter. When the probe is dry, the float rests on the bottom of the baffle body such that the magnet does not influence the reed switch. As the probe becomes immersed in liquid, the float becomes buoyant and the magnet elevates causing the reed switch to change state.

Reed Switch Rating		Max. Resistive Load		Reed Switch Rating		Max. Resistive Load	
VA	Volts	Amps AC	Amps DC	VA	Volts	Amps AC	Amps DC
15	0-50	0.3	0.21	50	0-50	0.5	0.5
	120	0.13	0.09		120	0.4	0.4
	240	0.06	0.04		240	0.2	0.2

## Dimensions

(LV10-1301, LV10-1351, LV10-5301, LV10-5351)

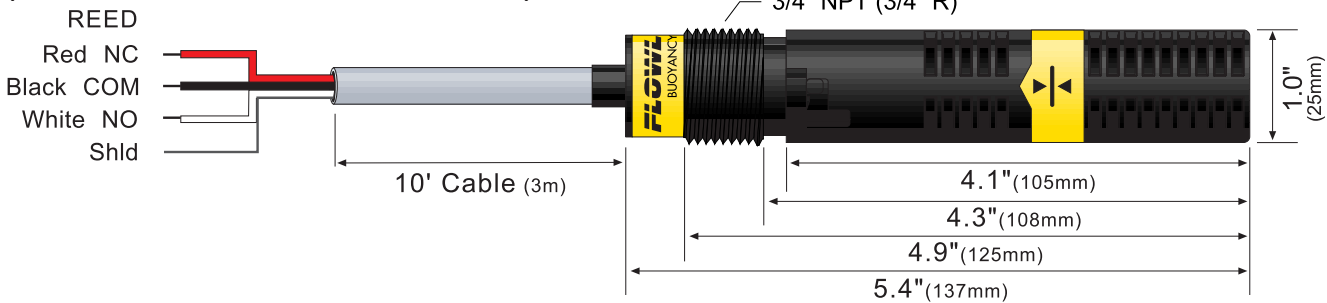

(LV10-1201, LV10-1251, LV10-5201, LV10-5251)

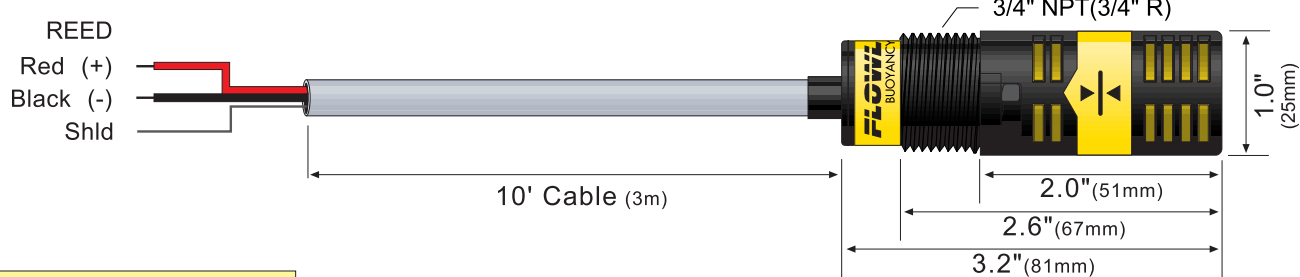

## Vertical Buoyancy & Float

LV10 -		1
<b>Sensor Material</b>	1 - PP	
	5 - PVDF	
<b>Sensor Length</b>	2 - 3.2" (81 mm)	
	3 - 5.4" (137 mm)	
<b>Mounting Thread</b>	0 - 3/4" NPT	
	5 - 3/4" BSP	

## SAFETY PRECAUTIONS

### Step Two

#### ⚠ About this Manual:

PLEASE READ THE ENTIRE MANUAL PRIOR TO INSTALLING OR USING THIS PRODUCT. This manual includes information on the vertical buoyancy, model LV10-3\_1, and vertical float switch, model LV10-2\_1. Please refer to the part number located on the sensor label to verify the exact model which you have purchased.

#### ⚠ User's Responsibility for Safety:

FLOWLINE manufactures a wide range of liquid level switches and technologies. While each of these switches are designed to operate in a wide variety of applications, it is the user's responsibility to select a switch model that is appropriate for the application, install it properly, perform tests of the installed system, and maintain all components. The failure to do so could result in property damage or serious injury.

#### ⚠ Proper Installation and Handling:

Because this is an electrically operated device, only properly trained staff should install and/or repair this product. Use a proper sealant with all installations. Never overtighten the sensor within the fitting, beyond a maximum of 80 inch-pounds torque. Always check for leaks prior to system start-up.

#### ⚠ Material Compatibility:

The LV10 level switch is available in two wetted material versions. The switch and cable are made of Polypropylene (PP) for the LV10-1\_\_1. The switch is made of Polyvinylidene Fluoride (PVDF) and cable is made of Perfluoroalkoxy (PFA) for the LV10-5\_\_1. Make sure that the switch is compatible with the application liquids. To determine the chemical compatibility between the sensor and its application liquids, refer to the Compass Corrosion Guide, available from Compass Publications (858-589-9636).

#### ⚠ Temperature and Pressure:

The LV10 series switch is designed for use in application temperatures up to 80 °C, and for use at pressures up to 25 psi (2 bar) @ 25 °C., derated @ 1.667 psi (.113 bar) per °C. above 25 °C.

#### ⚠ Wiring and Electrical:

The supply voltage used for the LV10 switch should never exceed 120 volts AC @ 15 VA for the LV10-3\_1 and 120 volts AC @ 50 VA for the LV10-2\_1. For the CE versions, the supply voltage for the LV10 switch should never exceed 30 Vrms and 42.4 Vpeak or 60 VDC. Electrical wiring of the switch should be performed in accordance with all applicable national, state, and local codes.

#### ⚠ Flammable, Explosive and Hazardous Applications:

The LV10 series switch should not be used within flammable or explosive applications unless properly connected to a approved control device. In hazardous applications, use redundant measurement and control points, each having a different sensing technology. Refer to the National Electrical Code (NEC) for all applicable installation requirements in hazardous locations.

#### ⚠ WARNING ⚠

*Please observe the difference in wiring and operation between the LV10-3\_1 and the LV10-2\_1.*

*Avoid installing the LV10 in tanks in magnetized metal tanks. Doing so will activate the internal reed switch.*

## INSTALLATION

### Step Three

#### Through Wall Installation:

FLOWLINE's LV10 switch may be installed through the top wall of a tank. The sensor has male 3/4" NPT threads and a 3/4" bayonet adapter on the LV10-3\_1. This enables the user to mount the LV10 using either FLOWLINE's Smart Trak™ or FLOWLINE's Switch Pak™.

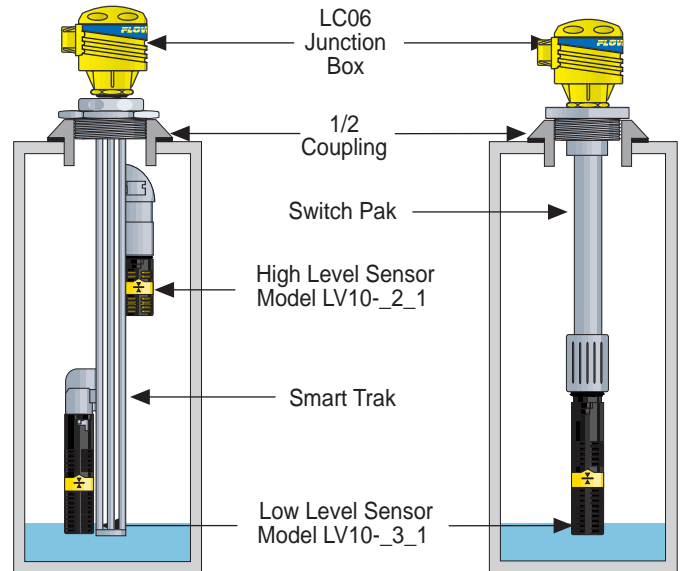

**Note: Avoid installing the LV10 in magnetized metal tanks. Doing so will activate the internal reed switch.**

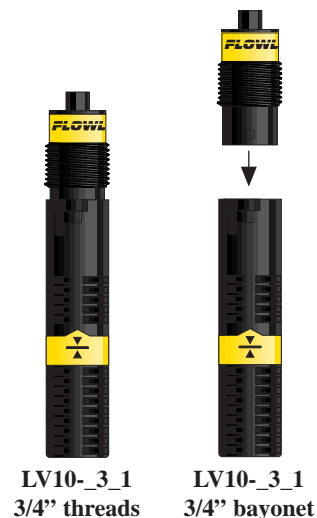

## INSTALLATION

### Step Four

#### Orientation:

Mounting orientation must be kept vertical for proper operation. The vertical buoyancy and float switches are orientated in the vertical position  $\pm 20^\circ$ .

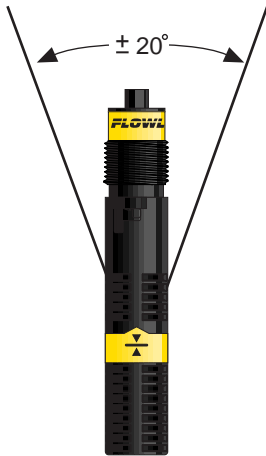

#### Removing Baffle (LV10-\_2\_1 Only):

The vertical float, model LV10-\_2\_1, can be installed with out the protective shield. To do so, remove the shield by twisting it off from the bayonet adapter. Make sure the C-clip is added to the post to prevent the float from falling off.

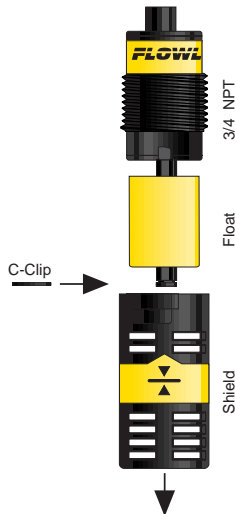

#### Output Selection (LV10-\_2\_1 Only):

The selection of normally open or normally closed for the LV10-\_2\_1 is made by the orientation of the float. The switch arrives from the factory in the NO position (open circuit when dry). The top of the float is identified by the rough edges at the end of the float. The smooth end is the bottom of the float. To change to NC, rotate the float 180°.



## ELECTRICAL

### Step Five

#### Voltage:

The input voltage to the LV10 switch should never exceed the maximum voltage rating. FLOWLINE controllers have a built-in 13.5 VDC power supply which provides power to all of FLOWLINE's level switches. Alternative controllers and power supplies may also be used with the LV10 switch.

#### Cable Length:

Determine the length of cable required between the LV10 series sensor and its point of termination. Allow enough slack to ensure the easy installation, removal and/or maintenance of the sensor. The cable length may be extended up to a maximum of 1000 feet, using a well-insulated, 18 gauge shielded wire.

#### Wire Stripping:

Using a 10 gauge wire stripper, carefully remove the outer layer of insulation from the last 1-1/4" of the sensor's cable. Unwrap and discard the exposed foil shield from around the signal wires, leaving the drain wire attached if desired. With a 20 gauge wire stripper, remove the last 1/4" of the colored insulation from the signal wires.

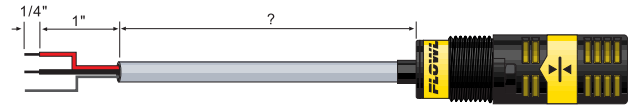

# WIRING

## Step Six

All Models:  
Wiring to a FLOWLINE Controller

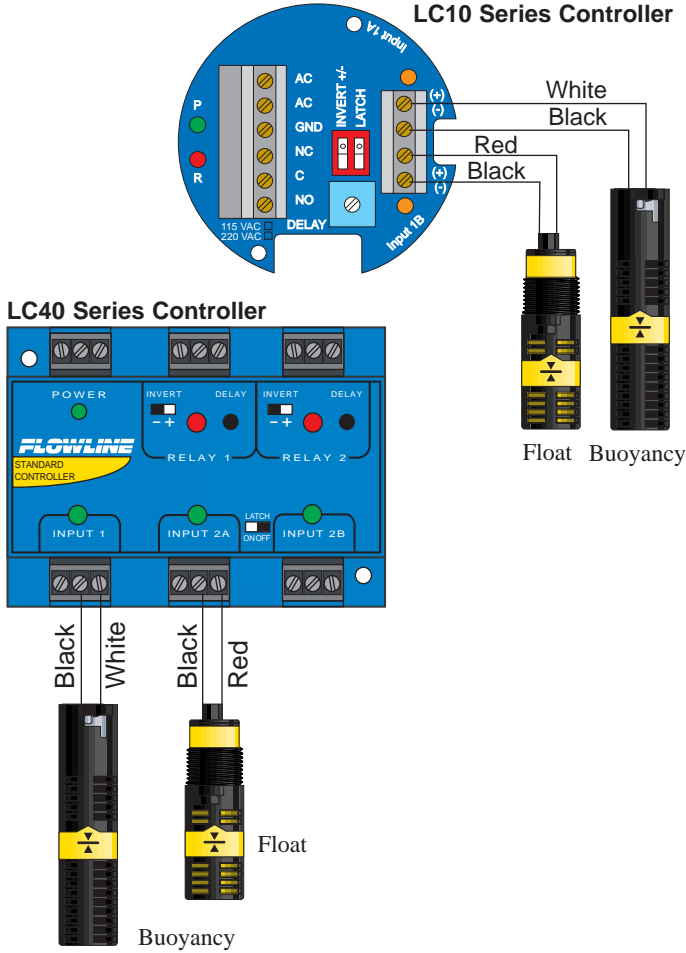

**Note:** Above wiring is for NO operation (open circuit when switch is dry and closed circuit when switch is wet). To wire NC (closed circuit when dry and open circuit when wet), use RED and BLACK wires for the LV10-3\_1 or reverse the float for the LV10-2\_1. Use the shield to protect the cable from electrical noise. Attach to either the Shield terminal or the ground terminal.

# ORIENTATION

## Step Seven

### Vertical Buoyancy Level Switch (LV10-3\_1):

The LV10-3\_1 switch can be wired normally open or normally closed for your application requirement.

#### Normally Open:

Use the Black and White wires for operating the LV10-3\_1 in a normally open state. Normally open is defined as the switch being open when the float is dry and closed when the float becomes submerged. This operation is typical for indicating a high level.

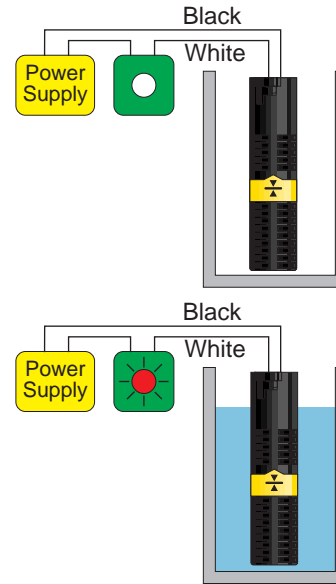

#### Normally Closed:

Use the Black and Red wires for operating the LV10-3\_1 in a normally closed state. Normally closed is defined as the switch being closed when the float is dry and open when the float becomes submerged. This operation is typical for indicating a low level.

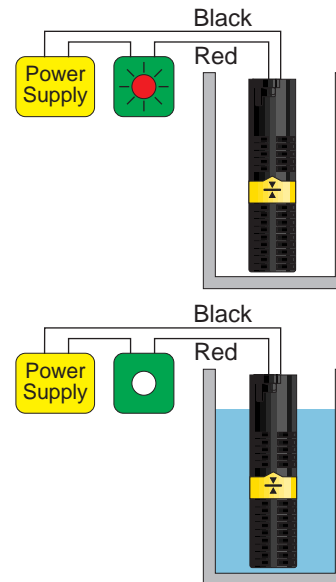

## ORIENTATION

### Step Eight

#### Vertical Float Level Switch (LV10-2\_1):

The LV10-2\_1 switch can be wired normally open or normally closed for your application requirement.

#### Normally Open:

Only use the Black and Red wires with the LV10-2\_1. Orientate the float upward so that the switch is in the normally open state. Normally open is defined as the switch being open when the float is dry and closed when the float becomes submerged. This operation is typical for indicating a high level.

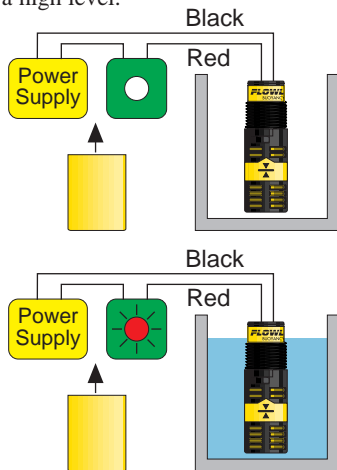

#### Normally Closed:

Only use the Black and Red wires with the LV10-2\_1. Orientate the float downward so that the switch is in the normally closed state. Normally closed is defined as the switch being closed when the float is dry and open when the float becomes submerged. This operation is typical for indicating a low level.

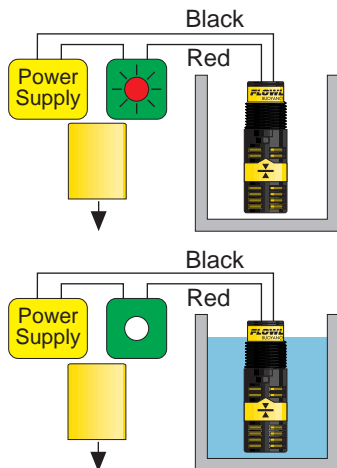

## MAINTENANCE

### Step Nine

#### General:

While a filter shroud protects the float from particulate contamination, the switch may need to be cleaned periodically to prevent jamming or sticking. The vertical buoyancy and vertical float has no scheduled maintenance requirement, except to clean off any deposits or scaling from the switch as necessary. It is the responsibility of the user to determine the appropriate maintenance schedule, based on the specific characteristics of the application liquid.

#### Cleaning procedure:

1. **Power:** Make sure that all power to the switch, controller and/or power supply is completely disconnected.
2. **Switch removal:** If necessary, make sure that the tank is drained well below the switch prior to removal. Carefully, remove the sensor from the installation. Remove the outer screen by pushing on the screen and turning it slightly to disconnect it from the bayonet connector so that the float is exposed.
3. **Cleaning the switch:** Using a soft bristle brush and mild detergent, carefully wash the switch. Do not use harsh abrasives such as steel wool or sandpaper, which might damage the surface of the sensor. Do not use incompatible solvents which may damage the sensor's PP or PVDF plastic body. Take particular care to remove any scaling from the float body and make sure that it moves freely.
4. **Sensor installation:** Follow the appropriate steps of installation as outlined in the Installation section of this manual.

#### Testing the installation:

1. **Power:** Turn on power to the controller and/or power supply.
2. **Immersing the switch:** Immerse the sensing tip in its application liquid, by filling the tank up to the switch's point of actuation. An alternate method of immersing the switch during preliminary testing is to hold a cup filled with application liquid up to the switch's tip.
3. **Test:** With the switch being fluctuated between wet and dry states, the switch indicator light in the controller should turn on and off. If the controller doesn't have an input indicator, use a voltmeter or ammeter to ensure that the switch produces the correct signal.
4. **Point of actuation:** Observe the point at which the rising or falling fluid level causes the switch to change state, and adjust the installation of the switch if necessary.