

AMETEK®
PATRIOT SENSORS

Series 1989
Gemco™
 Quik-Set™ III High Resolution
 Single Turn & Multi-Turn PLS

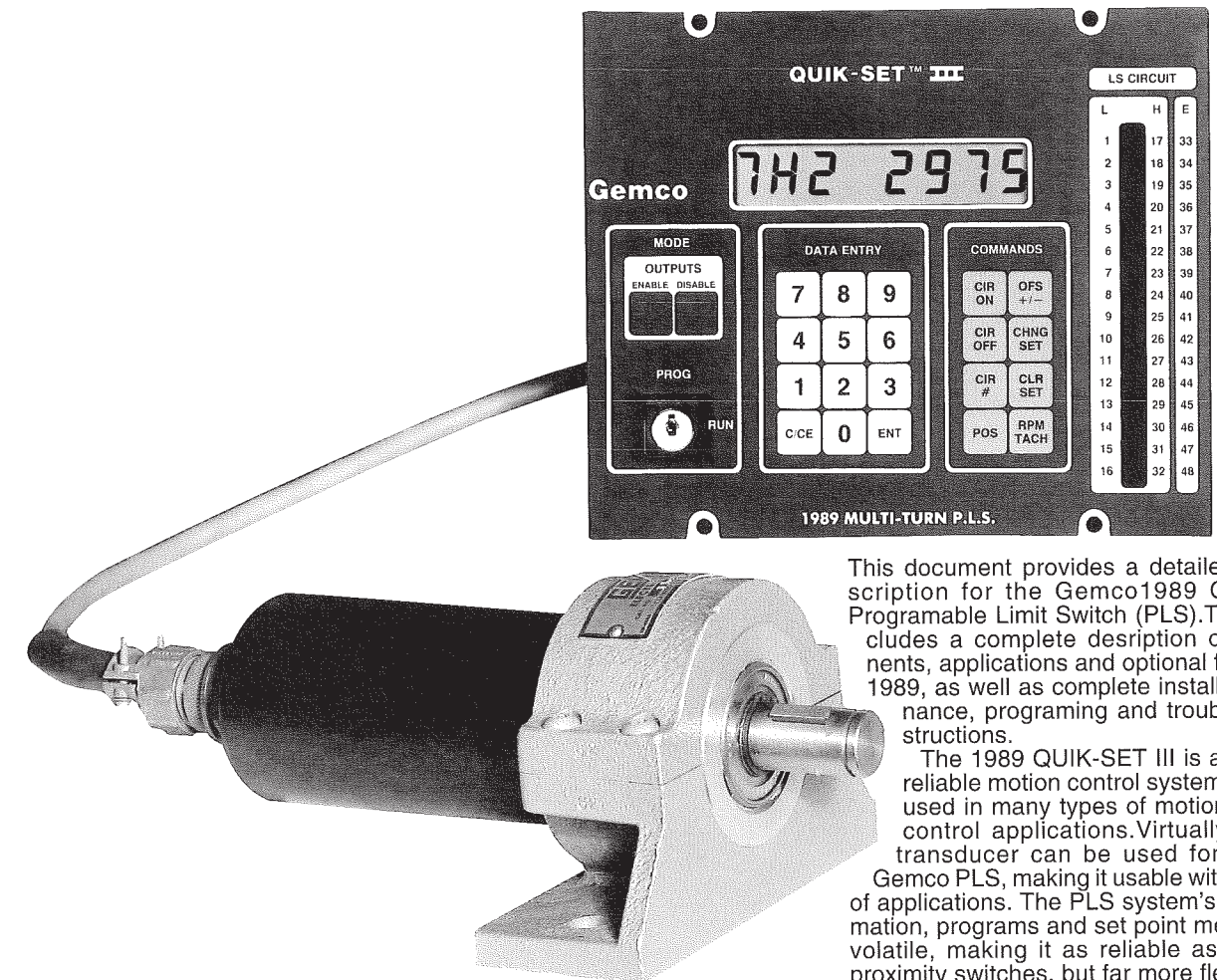

This document provides a detailed system description for the Gemco1989 QUIK-SET III Programable Limit Switch (PLS). The manual includes a complete description of the components, applications and optional features of the 1989, as well as complete installation, maintenance, programming and troubleshooting instructions.

The 1989 QUIK-SET III is a versatile and reliable motion control system which can be used in many types of motion and process control applications. Virtually any kind of transducer can be used for input with a Gemco PLS, making it usable with a wide range of applications. The PLS system's position information, programs and set point memory are non volatile, making it as reliable as fixed limit or proximity switches, but far more flexible.

The remainder of this manual will describe in detail all the advanced features of the 1989, which include: up to 48 output channels; 8 separate programs which are keypad selectable; compatibility with single- or multi-turn resolvers and two-axis systems; and virtually limitless combinations of option and features.

Installation Manual

AMETEK®
PATRIOT SENSORS

Spec Tech Industrial 203 Vest Ave. Valley Park, MO 63088 Phone: 888 SPECTECH
 E-mail: sales@spectechind.com www.spectechind.com

741A
 1989.M1F1
 10/00 • Z46
 IM

TABLE OF CONTENTS

I.	INTRODUCTION/DESCRIPTION		V.	PROGRAMMING	
	Problem Solving Procedures	3		Keyboard Functions	29
	Introduction	4		Scale Factor	29
	Production	4		Decimal Point	30
	Product Components Diagram	4		Offset Value	30
	Product Components Description	5		Set Points	31
				Motion Detection	31
II.	PART NUMBERING		VI.	ADVANCED FEATURES AND OPTIONS	
	Part Numbering	6-11		Analog Outputs	32
III.	INSTALLATION			Digital Outputs	32
	Introduction	13		Fault Check	32
	Mechanical Installation	13		Dual Axis Differential	33
	Mounting Diagrams	13		RS232/RS485 Communications	33
	CPU Module Only	13		Multiprogram	34
	Display and CPU Module	14		Reset to Preset	34
	Display Module Only	14		Remote Serial Display	34
	P.C. Interface Output Module	15		Brake Monitor	35
	Solid State Output Module	15		Time-based Outputs	35
	Mechanical Output Module	16		Selectable Speed Offset	36
	Electrical Installation	16	VII.	TROUBLESHOOTING	
	Wiring Instructions	16		Introduction	37
	Wiring Diagram Reference Chart	17		Inputs	37-40
	General Wiring Diagram	18-19		Outputs	40-41
	Transducer to Controller -			Relay Output Modules	41
	Dual Resolver	20		Output Relays	41
	Series 950CP Linear Transducers	21		Electrical Noise	41-42
	Output Wiring Selections	22-23		Troubleshooting Symptom Guide	43-44
	Brake Monitor - Option S	24	VIII.	APPENDICES	
	Optional Output Board -			Replacement Part Information	45
	Options A, H and R	24		Additional Available Wiring Diagrams	46
	Fault Check and				
	Auxiliary Digital Outputs	25			
	Typical Wiring of 32 and				
	48 Circuit Systems	26			
	Internal Wiring of Resolver and				
	Cable Assemblies	27			
IV.	SPECIFICATIONS				
	Programmer Specifications	28			
	Programmer Output Types	28			
	Auxiliary Outputs	28			
	High Power Output Modules	28			

PROBLEM SOLVING PROCEDURES

If you are having trouble with your 1989 PLS system, follow this step-by-step procedure for the quickest correction.

First, always check system connections at the transducer, programmer, and output module to ensure that all connectors and wires are secured. A slight tug on each wire at the programmer connectors is also recommended. Verify that all wiring to the programmer matches the programmer data plate.

The next step is to check the input power to output module/power supply. Input voltage should be 115 V AC or 230 V AC $\pm 10\%$ depending on the voltage rating of the module. Also verify that the line fuse has not blown.

It is important to check the DC operating voltages at the programmer CPU module S2 connector.

Finally, check the transducer excitation on the programmer S1 connector, a shorted resolver wiring may cause a failure in the programmer. For more information concerning these problems, refer to the troubleshooting section on pages 31-37.

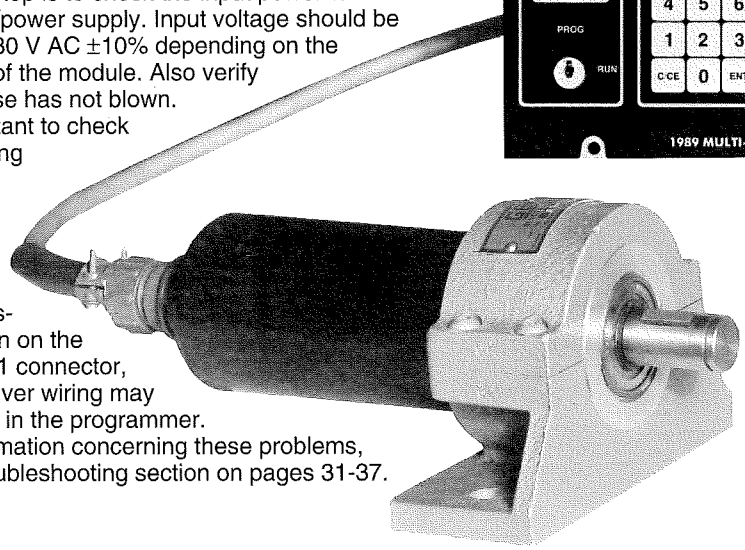
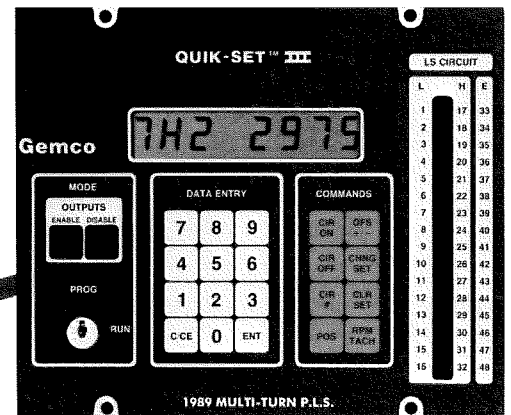

For technical information, service and application engineering assistance, or additional copies of this documentation, contact:

Ametek Patriot Sensors
1080 North Crooks Road
Clawson, Michigan 48017-1097

Telephone: (248) 435-0700
Facsimile: (248) 435-8120

If you are having problems with the 1989 PLS and have been unable to solve them with the troubleshooting procedures explained on pages 30-37, call a Customer Service Engineer.

For best service, make sure you have the following information before you call:

- a: system catalog number
- b: serial number of the unit
- c: your order number (if available)
- d: application information
- e: detailed description of the problem including self-diagnostic test results
- f: history of your product and previous problems with it.

I.

INTRODUCTION / DESCRIPTION

INTRODUCTION

The standard 1989 QUIK-SET III is a fully integrated microcomputer-based Programmable Limit Switch (PLS) with a convenient keypad for programming each independent output circuit to open or close at the desired settings. The system allows precise position control of either rotary or linear motion. This can be done through the keypad or by a remote programmable controller, computer, or via any remote serial data link using RS-232 or RS-485 communications.

The PLS receives a signal from the input device (transducer) and converts the signal to the appropriate binary code.

As the input device (transducer) passes through the pre-programmed dwell settings, the programmer outputs can energize solenoids, relays or solid state circuitry to control external circuits. Auxiliary digital and/or analog outputs based on position or velocity are available for use by remote control devices.

PRODUCT DESCRIPTION

A typical 1989 PLS system consists of an input device, a programmer and an output module. The programmer consists of a display module and a CPU module. There are several input devices which can be used with this system as long as the proper interfacing is used in the CPU module. The input devices which may be used are as follows:

- Single Resolver
- Dual Resolver (Multi-turn)
- Magnetostrictive Linear Displacement Transducer
- Optical Encoder
- Analog
- LVDT (Available by special order only)
- Selsyn (Available by special order only)

PRODUCT COMPONENT DIAGRAM

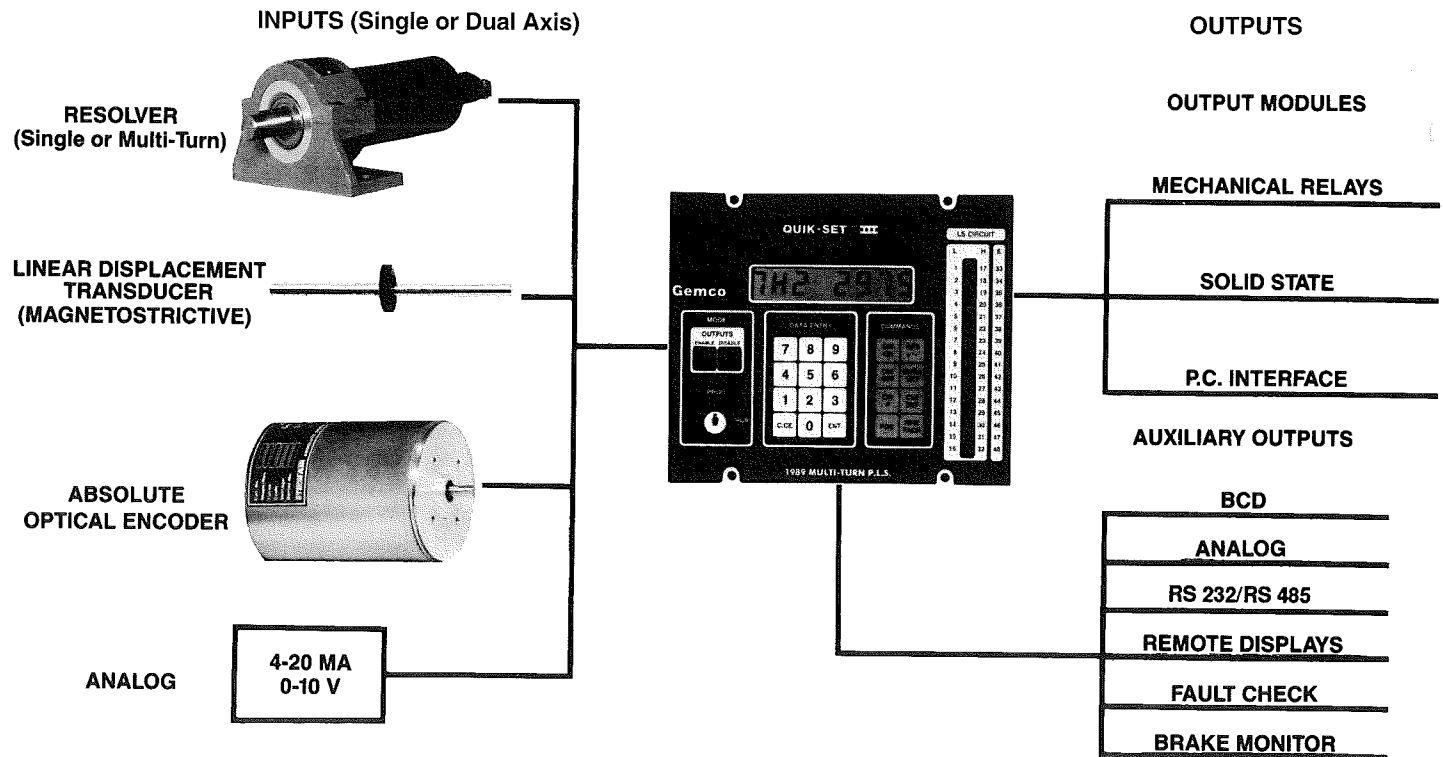

**PRODUCT
COMPONENT
DESCRIPTION**

Resolver transducers are highly accurate and reliable. They provide an absolute analog signal which varies as a function of the angular rotation of the input shaft. The two phase stator and single phase rotor of the resolver provide a ratiometric output that does not vary with changes in rotor voltage, frequency or temperature.

Brushless resolvers are available in heavy duty NEMA 4 enclosures with plug-in connectors. The 3/4 inch input shafts with sealed ball bearing faces result in the most rugged transducer available for industrial applications.

Single-turn resolvers are accurate to within 6 arc minutes. Multi-turn dual resolvers are available in 64- or 128-turn units. The PLS offers a 14 bit resolution (16,384) for the single turn unit, and resolution up to 14 bits per turn for the multi-turn units.

Absolute optical encoders can be used with the binary input version of the Series 1989 PLS. The position data from the encoder can be field scaled in the 1989 programmer to allow the programming of set points in pertinent engineering units.

Optional digital output boards can transmit this scaled position data to a remote PLC. This allows high-speed switching operations to be handled by the PLS and slower speed, special functions to be handled by the PLC.

Magnetostrictive Linear Displacement Transducers (LDT) provide absolute positioning with up to 14 bit resolution (16,384) with excellent linearity of .05%.

LDTs transmit a strain pulse through a magnetostrictive wire located inside a protective tube. This is done by the interaction of a current pulse and magnetic field from a movable magnet. The pulse travels at a given speed and precise linear positioning can be determined by measuring the time interval for the pulse to travel to the magnet.

Gemco's Series 950CP LDT will interface directly with the PLS via a proprietary RS-422 communications format. The analog output Series 950A LDT, or equivalent competitive device, can be used with the analog input 1989 PLS.

Analog input devices signal position to the controller using an analog signal. An analog to digital converter provides 12 bit (4096) resolution to the internal microcomputer.

The scale factor for analog input is keypad programmable over the range of the specified input. The selected scale factor will correspond to the highest analog voltage or current input value.

The 1989 programmer includes the following basic features: 16 circuits, each of which will accept multiple set points; non-volatile, non-battery backed memory; programming keypad; key locked program switch; programmable decimal point; programmable scale factor; full-scale offset; position or RPM display; choice of rotary or linear input transducer; NEMA 12 faceplate; motion detection; enable/disable switch; programming through zero; choice of output types; and 12 bit resolution.

The programmer display module is an all metal NEMA 12 faceplate that can be permanently mounted through a panel cut out. The faceplate contains an 8 digit LCD display, enable/disable keypad, key-locked program switch, data entry and command keys, and output status lights. In addition to the faceplate, the keypad module also contains an LCD display board, an LED board, a metal backplate, a cable for connection to the CPU module, and 2 keys for the PROG/RUN selector switch.

The programmer CPU module is an all-metal assembly which can be mounted separately or can be screwed to the back of the display module to save mounting space inside the enclosure. This module consists of an I/O and transducer interface board, CPU board, expansion board (if required), and from 2 to 4 edge connector terminal strips.

The output module provides a high-power mechanical relay, P.C. interface, solid-state triac, or open collector outputs which can drive the machine control devices or a programmable controller. The output directly from the CPU module is normally capable of driving a programmable controller input card directly and the output module may not be necessary. If an output module is not used, a separate power supply is needed to provide the 5 VDC and 15 VDC required by the display and CPU modules.



PART NUMBERING

EXPLANATION OF CATALOG

UP TO 48 CIRCUIT QUIK-SET III WITH ALL SPECIAL OPTIONS

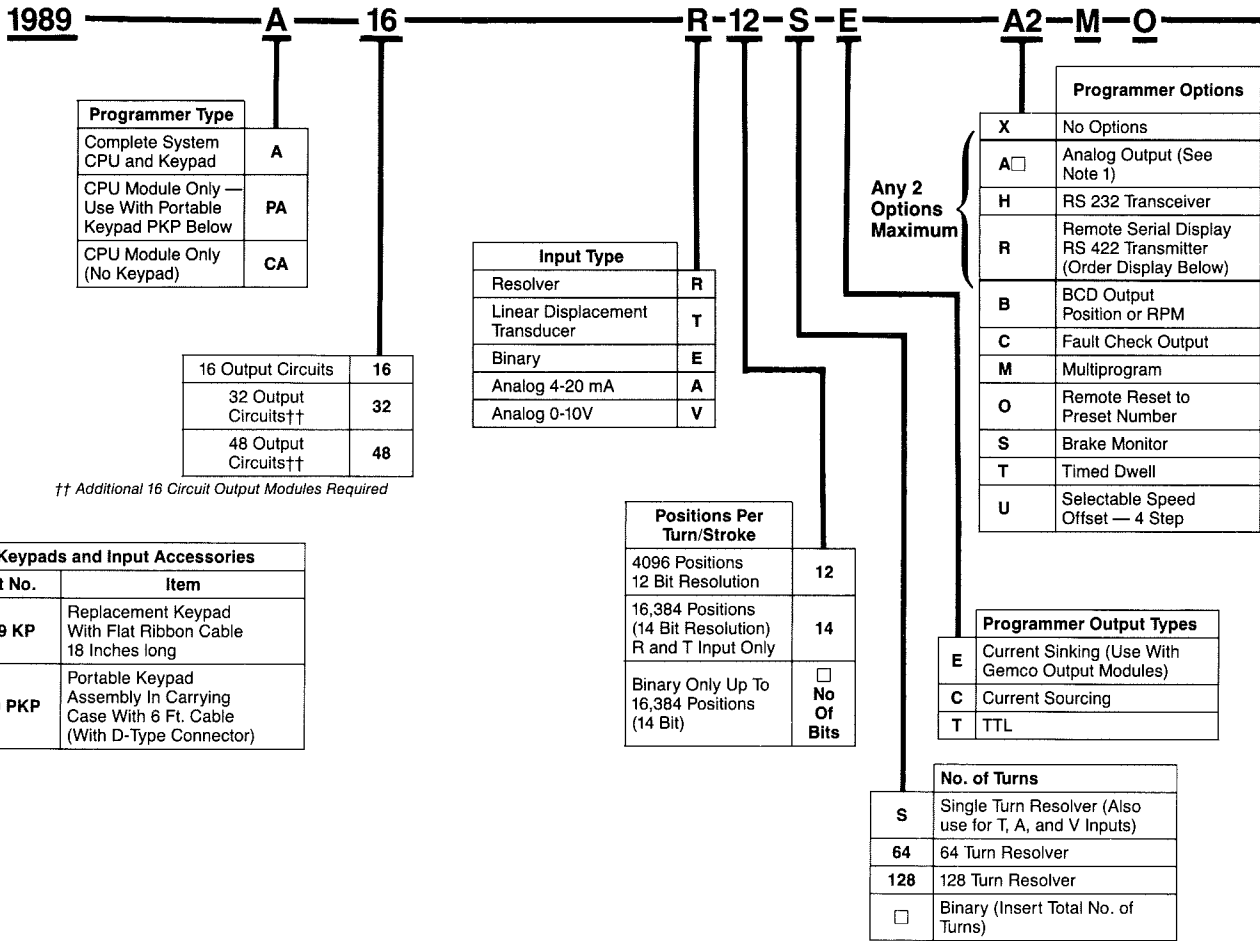

16 CIRCUIT HIGH POWER OUTPUT MODULES WITH POWER SUPPLY USE FOLLOWING PART NUMBER WHEN ORDERING SEPARATELY

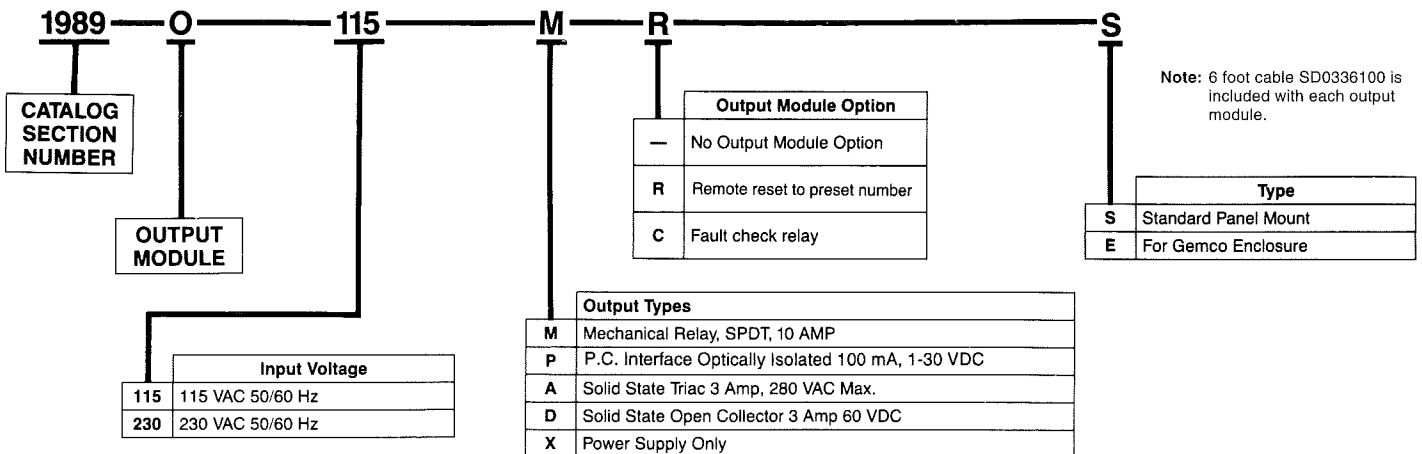



PART NUMBERING

OG NUMBERING SYSTEM

CONTINUE SEQUENCE ONLY IF OUTPUT MODULES TO BE FACTORY ASSEMBLED INSIDE OF ENCLOSURE. IF NOT, ORDER OUTPUT MODULES ON BOTTOM OF PAGE 8.

NOTE 1: Insert number to specify type of analog output.

- 1 0 to 10V DC
- 2 -10 to +10V DC
- 3 4 to 20 mA

NOTE 2: If the remote reset feature is activated by a 110V AC input, an output module having the remote reset option should be ordered.

NOTE 3: Fault check output signal from CPU Module is designed for use with fault check relay on output module. Specify output module option C if ordering output module.

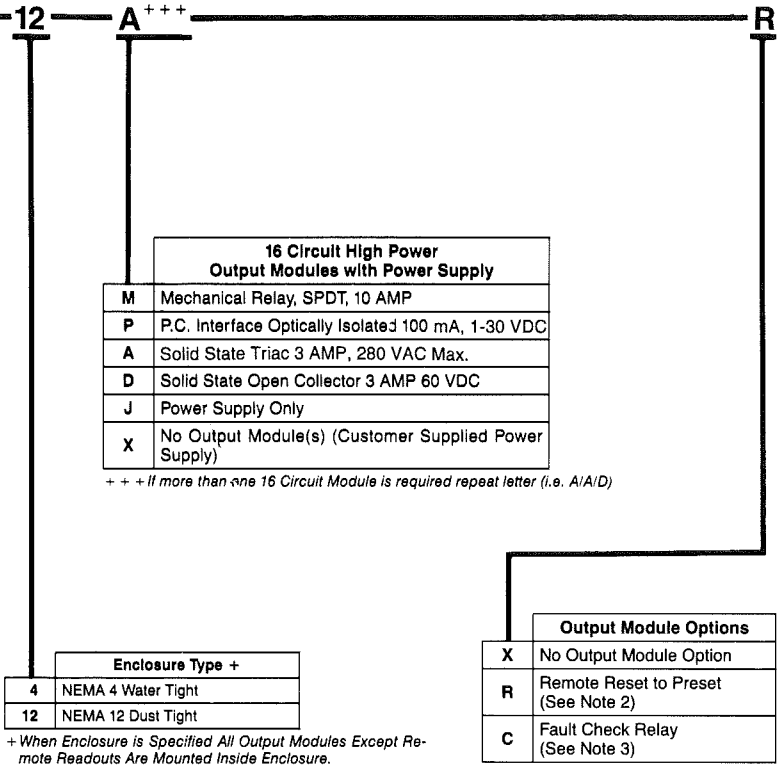

Cable Assemblies		
Part No.	Item	Length
SD0334200***	Single Resolver to Programmer	15 ft.
SD0334900***	Dual Resolver to Programmer	15 ft.
SD0336100	Programmer to Output Module (spares)	6 ft.
SD0336300	Programmer To Output Module w/Remote Reset (spares)	6 ft.
SD0300800	2 Conductor Shielded Remote Readout	25 ft.
SD0322900	Keypad To Programmer Ribbon Cable (spares)	18 in.

***Transducer to programmer cable assemblies must be ordered separately.

Resolver Transducers	
Part No.	Item
SD0284200	Standard 3/4" Input Shaft NEMA 4
Consult Factory	Cable Driven-Spring Return Transducer-Specify Travel to 100"
SD0410900	Dual Resolver 64 Turns
SD0410901	Dual Resolver 128 Turns

Remote Serial Display (Programmer Option R)	
Part No.	Description
SD-3527-C*	4 Digit Display
SD-3435-C*	8 Digit Display

*Includes 25 foot cable SD0300800



PART NUMBERING

EXPLANATION OF CATALOG

16 CIRCUIT QUIK-SET III WITH STANDARD OPTION PACKAGE

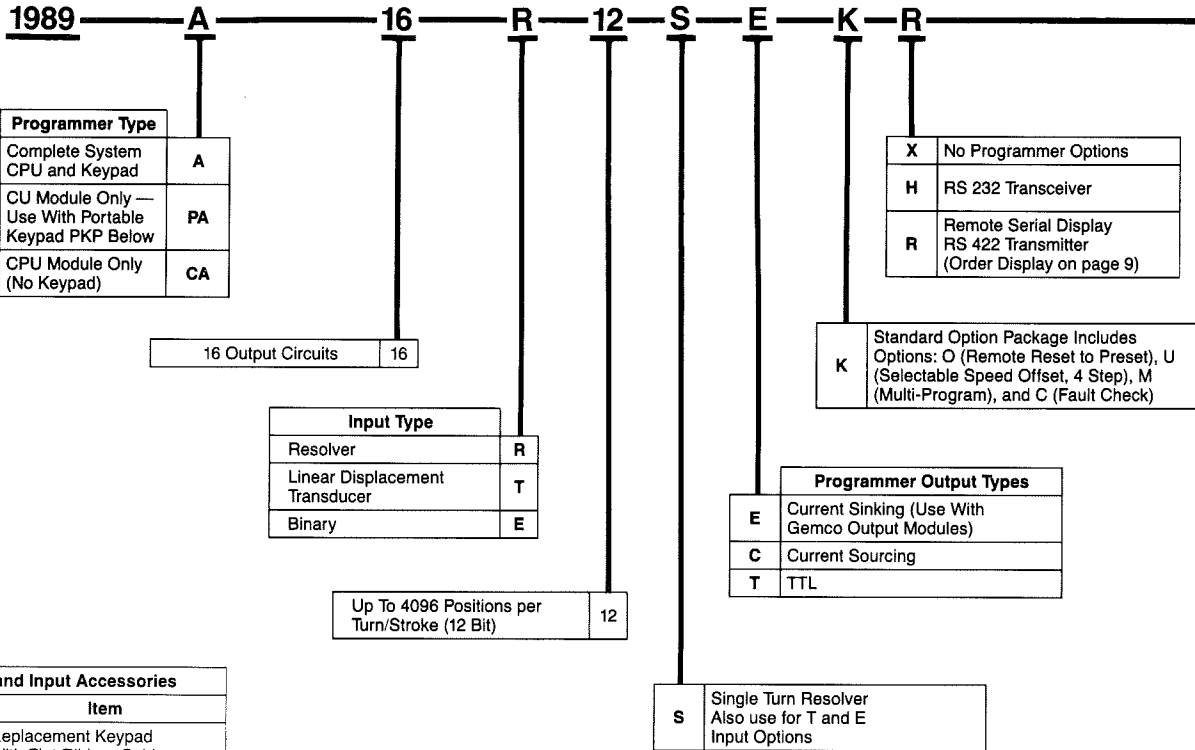

Keypads and Input Accessories	
Part No.	Item
1989 KP	Replacement Keypad With Flat Ribbon Cable 18 Inches Long
1989 PKP	Portable Keypad Assembly In Carrying Case With 6 Ft. Cable (With D-Type Connector)

DUAL AXIS QUIK-SET III

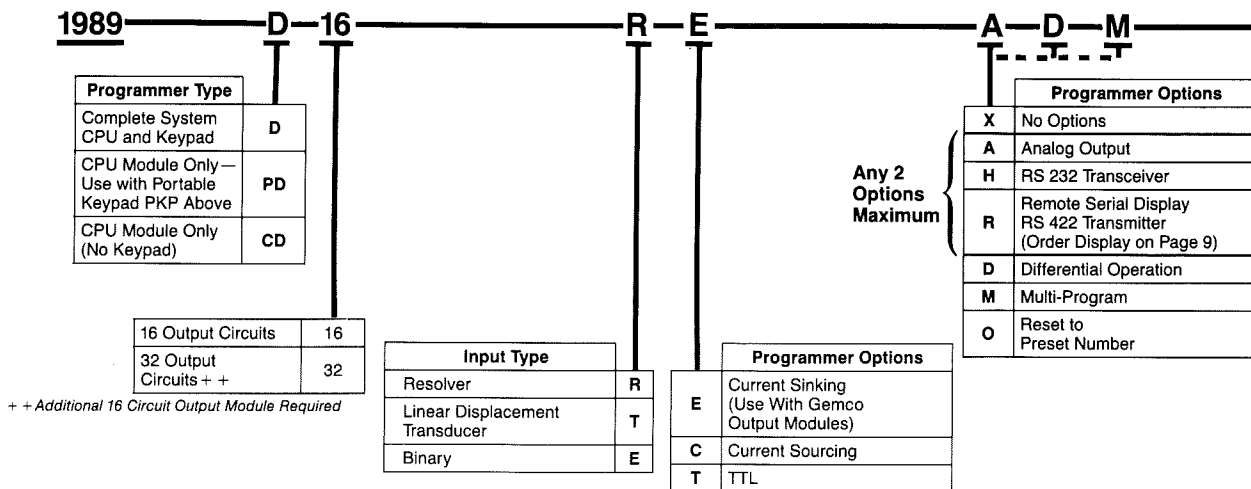

II.

PART NUMBERING

OG NUMBERING SYSTEM

CONTINUE SEQUENCE ONLY IF OUTPUT MODULES TO BE FACTORY ASSEMBLED INSIDE OF ENCLOSURE. IF NOT, ORDER OUTPUT MODULES ON BOTTOM OF PAGE 8.

NOTE 1: If the remote reset feature is activated by a 110V AC input, an output module having the remote reset option should be ordered.

NOTE 2: Fault check output signal from CPU module is designed for use with fault check relay on output module. Specify output module option C if ordering output module.

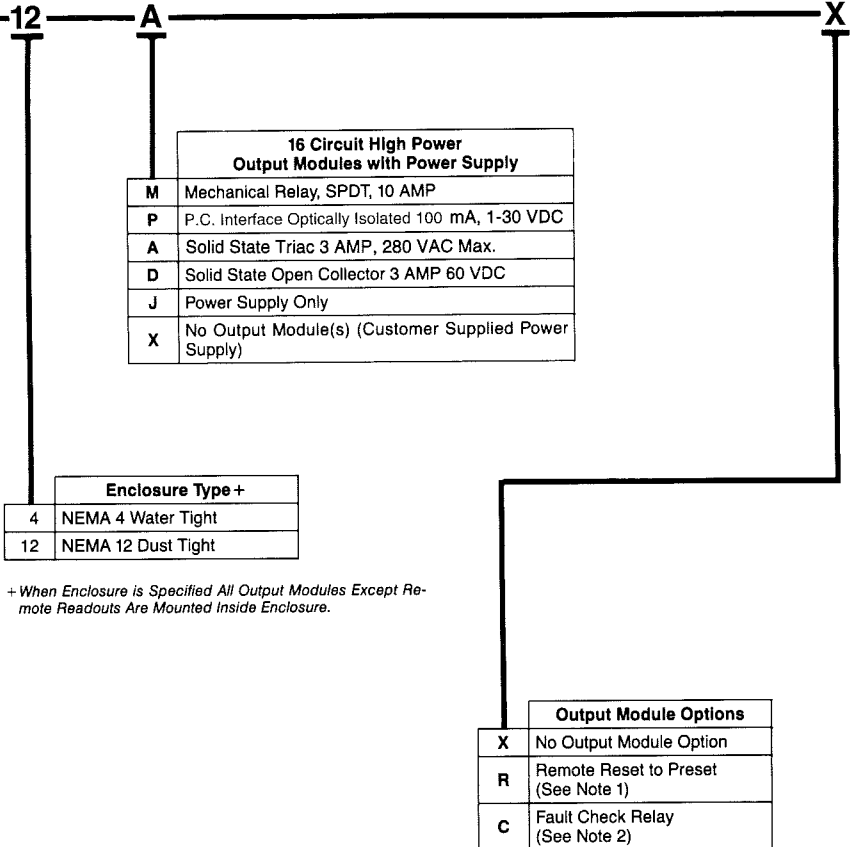

CONTINUE SEQUENCE ONLY IF OUTPUT MODULES TO BE FACTORY ASSEMBLED INSIDE OF ENCLOSURE. IF NOT, ORDER OUTPUT MODULES ON BOTTOM OF PAGE 8.

NOTE 1: If the remote reset feature is activated by a 110V AC input, an output module having the remote reset option should be ordered.

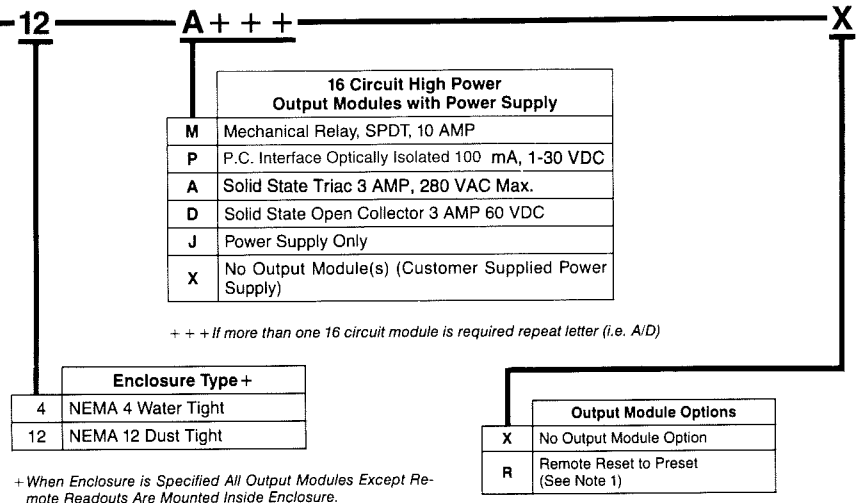



PART NUMBERING

EXPLANATION OF CATALOG

UP TO 48 CIRCUIT QUIK-SET III WITH ALL SPECIAL OPTIONS

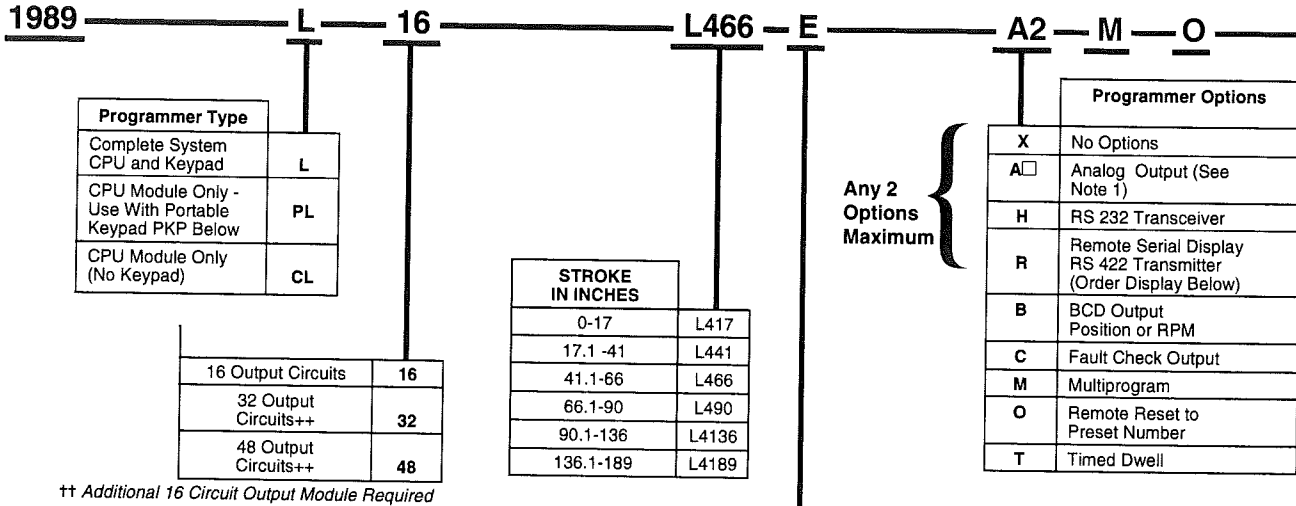

Keypads and Input Accessories	
Part No.	Item
1989 KP	Replacement Keypad With Flat Ribbon Cable 18 Inches long
1989 PKP	Portable Keypad Assembly in Carrying Case With 6 Ft. Cable (With D-Type Connector)

DUAL AXIS QUIK-SET III

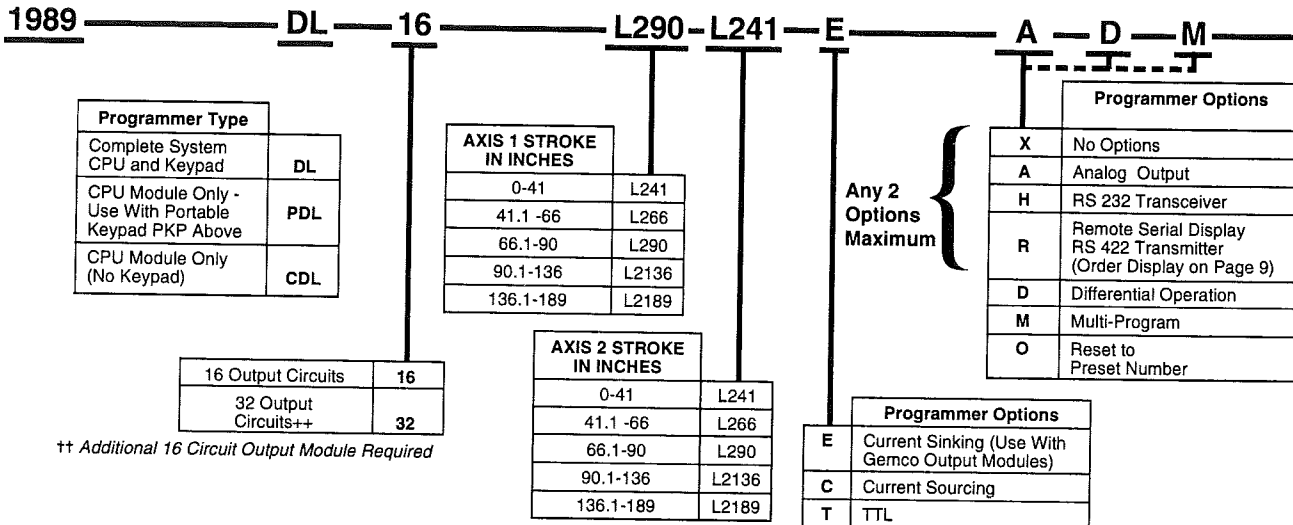



PART NUMBERING

OG NUMBERING SYSTEM

CONTINUE SEQUENCE ONLY IF OUTPUT MODULES TO BE FACTORY ASSEMBLED INSIDE OF ENCLOSURE. IF NOT, ORDER OUTPUT MODULES ON BOTTOM OF PAGE 8.

NOTE 1: Insert number to specify type of analog output.

- 1 0 to 10V DC
- 2 -10 to +10V DC
- 3 4 to 20 mA

NOTE 2: If the remote reset feature is activated by a 110V AC input, an output module having the remote reset option should be ordered.

NOTE 3: Fault check output signal from CPU Module is designed for use with fault check relay on output module. Specify output module option C if ordering output module.

NOTE 4: The 950 CP linear transducer requires a 24V DC 200 mA power supply. Order power supplies J and K if both are to be installed in the enclosure. Order PLS power supply from this price sheet and 950 CP linear transducer power supply from catalog Section 950 CP as separate items if system in enclosure is not specified.

12 — A⁺⁺⁺ — R

16 Circuit High Power Output Modules with Power Supply	
M	Mechanical Relay, SPDT, 10 AMP
P	P.C. Interface Optically Isolated 100 mA, 1-30 VDC
A	Solid State Triac 3 AMP, 280 VAC Max.
D	Solid State Open Collector 3 AMP 60 VDC
J	Power Supply Only for 1989 PLS
K	Power Supply Only for 950 LDT
X	No Output Module(s) (Customer Supplied Power Supply)

+++ If more than one 16 Circuit module is required repeat letter (i.e. A/A/D) See Note 4

Enclosure Type +	
4	NEMA 4 Water Tight
12	NEMA 12 Dust Tight

+ When Enclosure is Specified All Output Modules Except Remote Readouts Are Mounted Inside Enclosure.

Output Module Options	
X	No Output Module Option
R	Remote Reset to Preset (See Note 2)
C	Fault Check Relay (See Note 3)

CONTINUE SEQUENCE ONLY IF OUTPUT MODULES TO BE FACTORY ASSEMBLED INSIDE OF ENCLOSURE. IF NOT, ORDER OUTPUT MODULES ON BOTTOM OF PAGE 8.

NOTE 1: If the remote reset feature is activated by a 110V AC input, an output module having the remote reset option should be ordered.

NOTE 2: The 950 CP linear transducer requires a 24V DC 200 mA power supply. Order power supplies J and K if both are to be installed in the enclosure.

Order PLS power supply from this price sheet and the power supply for the 950 CP linear transducer from catalog section 950 CP as separate items if a system in an enclosure is not specified.

12 — A⁺⁺⁺ — X

16 Circuit High Power Output Modules with Power Supply	
M	Mechanical Relay, SPDT, 10 AMP
P	P.C. Interface Optically Isolated 100 mA, 1-30 VDC
A	Solid State Triac 3 AMP, 280 VAC Max.
D	Solid State Open Collector 3 AMP 60 VDC
J	Power Supply Only for Gemco PLS
K	Power Supply Only for 950 LDT
X	No Output Module(s) (Customer Supplied Power Supply)

+++ If more than one 16 Circuit module is required repeat letter (i.e. A/D)

Enclosure Type +	
4	NEMA 4 Water Tight
12	NEMA 12 Dust Tight

+ When Enclosure is Specified All Output Modules Except Remote Readouts Are Mounted Inside Enclosure.

Output Module Options	
X	No Output Module Option
R	Remote Reset to Preset (See Note 1)

III.

INSTALLATION

INTRODUCTION

This section describes the installation and wiring of a standard 1989, sixteen circuit programmer; 1989 output module; SD-2842-C single turn resolver; and SD-3342-B cable assembly ordered as separate parts. Changes to these instructions should be made according to your particular options and features.

Environmental Conditions:

The programmer and output module should always be installed in an area free of water spray, corrosive gases, flying chips or other foreign matter. The operating temperature should be kept between 32° and 125°F with less than 95% relative humidity.

MECHANICAL INSTALLATION

Mounting the Controller:

The display module should be mounted in the appropriate panel cutout and securely bolted into place using the four 3/16" diameter mounting holes. Secure the two keys and cable attached to the keypad package for later use.

The CPU module can either be connected directly to the back of the display module by four #6/32 screws, or mounted separately on a backplate inside the enclosure. Separately mounting the display and CPU modules is preferable because all I/O wiring is permanently in place and not subject to flexing when the panel door is opened and closed.

The output module is normally mounted inside the same enclosure, but it can be mounted up to 6' from the CPU module if necessary. For distances greater than 6', steps must be taken to insure sufficient DC voltage levels at the CPU module. Refer to page 9 wiring instructions.

Installation Tips:

It is good design practice to mount the display, CPU and output modules in the enclosure as far away from motor starters and control relays as possible. This is to minimize the effect of electromagnetic interference. Interconnecting wiring should also be routed to minimize EMI coupling.

Mounting the Transducer:

The transducer must be mounted securely to the machine so that shock and vibration are minimized. The transducer should be coupled to the moving machine member avoiding excessive axial and radial loads. Coupling methods should minimize backlash and be in accordance with the system accuracy required.

CPU Module (mounted separately)

OPTIONAL
TERMINALS FOR ANALOG
OUTPUT, REMOTE DISPLAY AND
D-TYPE CONNECTOR FOR RS 232/485

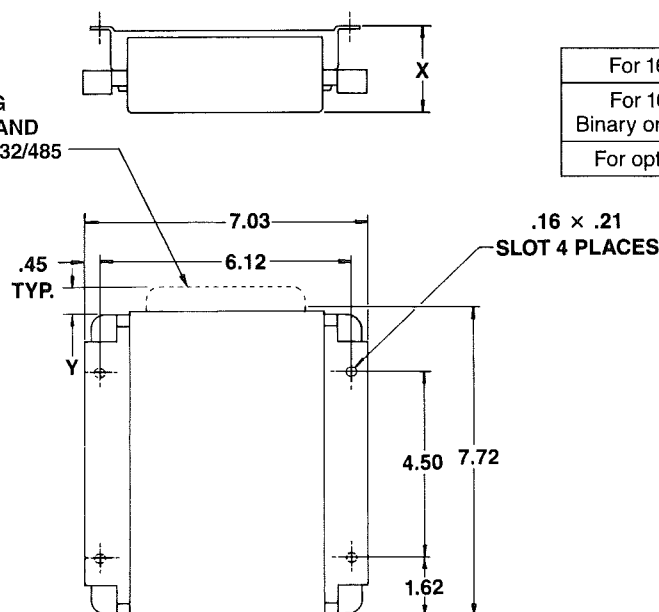

	Dimension X	Dimension Y
For 16 circuits only	2.14	0
For 16 circuits with Binary or 32 or 48 circuits	Add .76	0
For options A, H, or R	Add .76	1.38

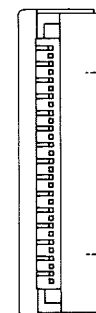

III.

INSTALLATION

Display Module and CPU Module (combined)

	Dimension X	Dimension Y
For 16 circuits only (no BCD output)	2.14	0
For 16 circuits with BCD or 32 or 48 circuits	Add .76	0
For options A, H, or R	Add .76	1.38

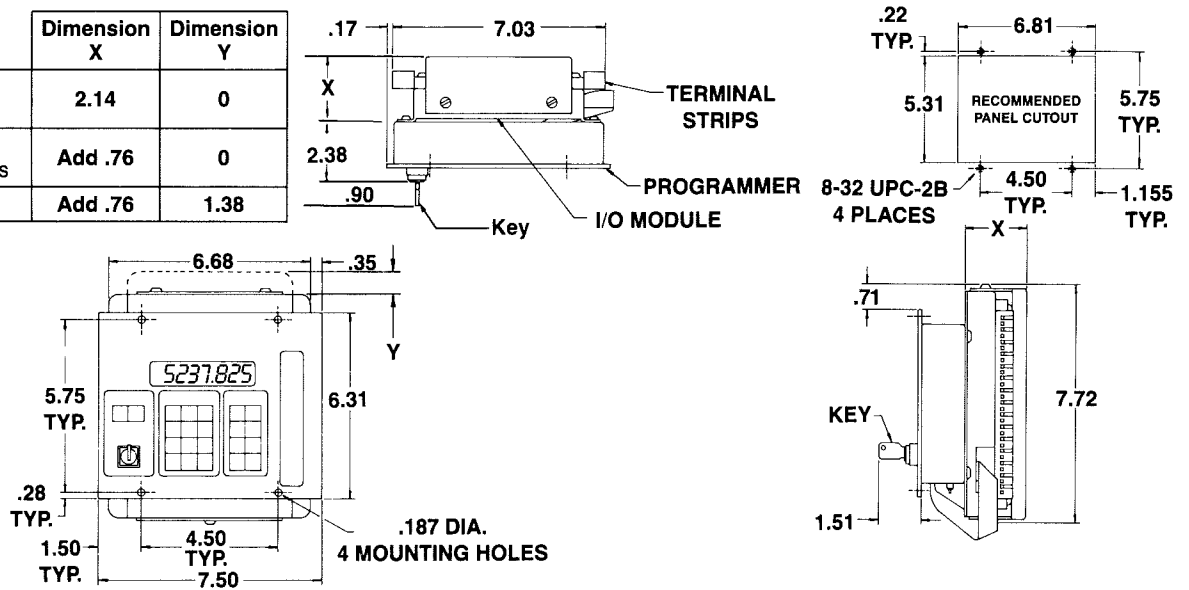

Display Module (mounted separately)

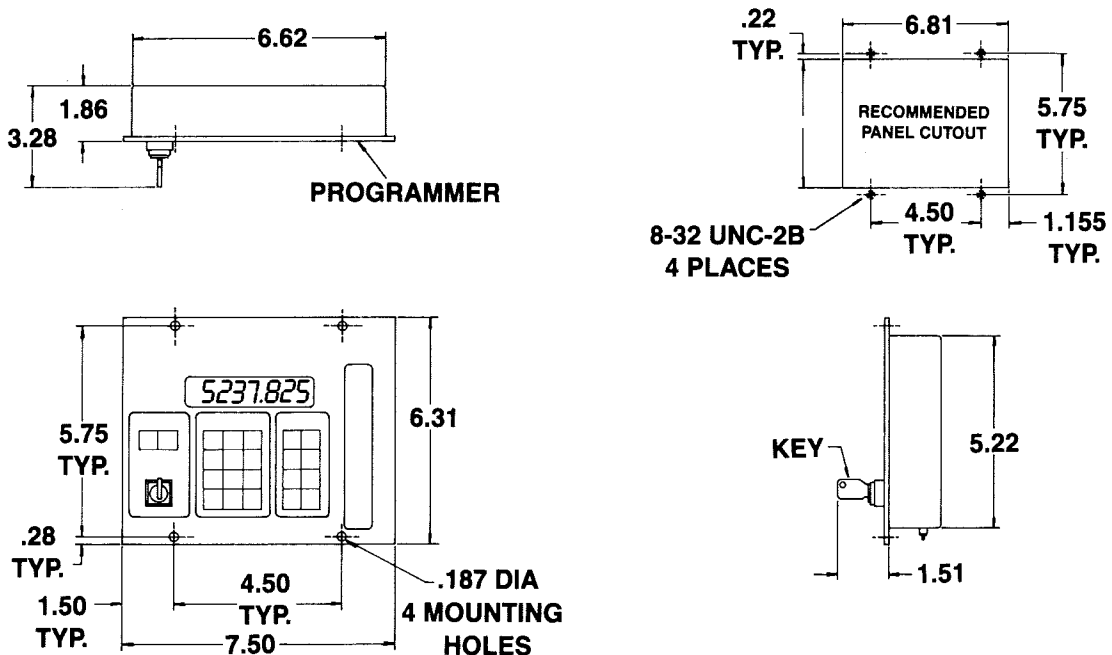

III.

INSTALLATION

Output Modules

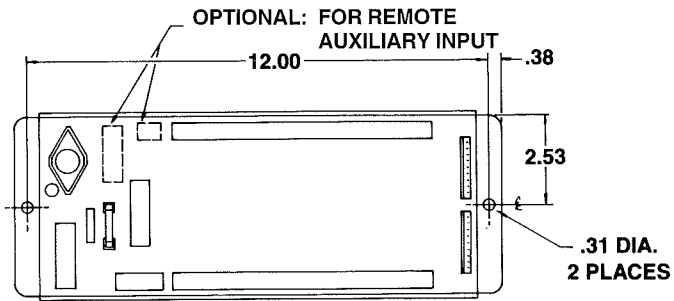

1989-0-115-P-S
P.C. Interface
Output Module
(16 Circuits)

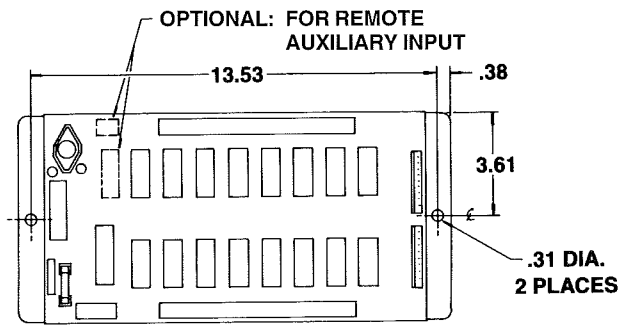
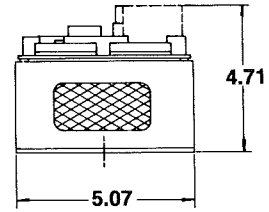
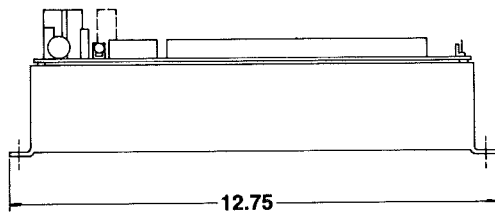

1989-0-115-A-S or 1989-0-115-D-S
AC or DC Solid State
Output Module

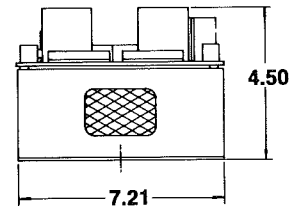
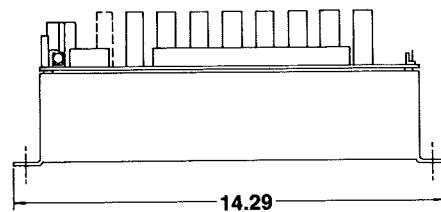

Output Module

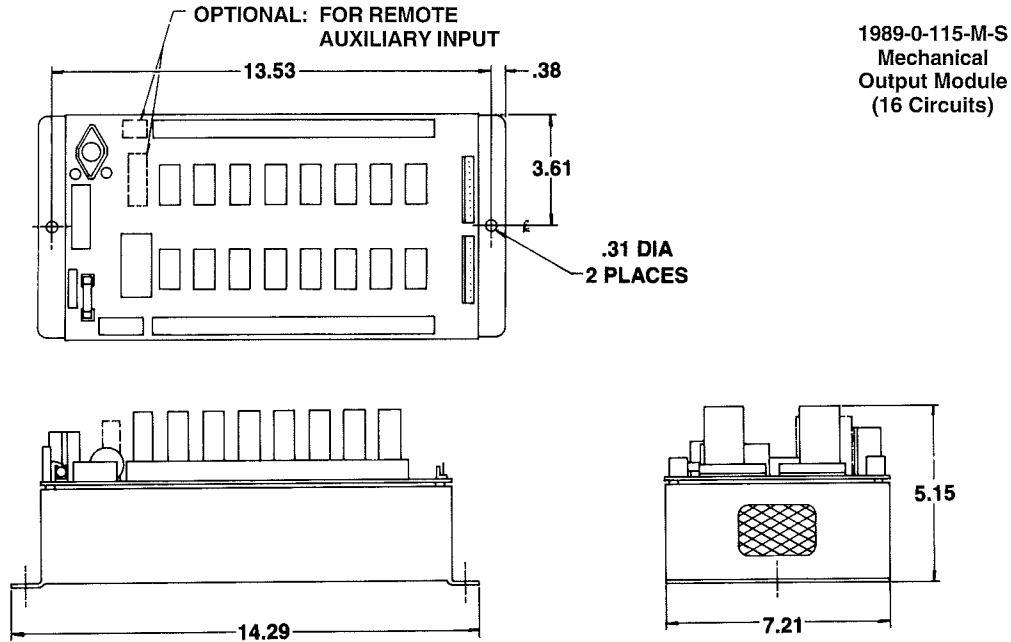

ELECTRICAL INSTALLATION

This system is designed for use in an industrial environment and incorporates extensive transient suppression circuitry. However, the same general installation rules that apply to all microprocessor-based equipment should be followed. Incoming AC lines must be from a clean power source. Lines carrying computer-level signals should not be routed in the same conduit as high-voltage, transient producing circuits, such as variable-speed drives, welders or DC switching circuits. High noise producing loads may require additional noise suppression devices.

The 1989 programmer is most often used with a single-turn resolver and one output module. See 1989 PLS General Wiring Diagram E-0190100-C, on pages 11-12 for this wiring combination. Various methods of wiring each of the optional output modules are described in drawings E-0193301-D and E-0193302-D, on pages 15-16.

Your CPU module legend plate and appropriate wiring diagrams taken from the Wiring Diagram Reference Chart (page 10) will define the details for your specific combination of options.

WIRING INSTRUCTIONS

Attach the pre-wired plug on the transducer cable to the transducer and route the shielded cable through a **separate** grounded metal conduit to the enclosure. Connect the edge connector to the CPU module. Be sure the shield connection is grounded to the case hold-down screw. When extensions to the factory supplied cable are necessary, a junction box should be used to connect the wire leads and cable shields from one cable to the other. Ground the cable shields at the controller case only.

Using the pre-wired shielded cable supplied with the output module, connect the larger terminal edge connector to the CPU module and the other connectors to the output modules. Connect the shield to the case hold-down screw on the CPU module. If the distance between the output module and CPU is greater than 6', the 5 VDC input to terminal strip S2 should be checked. If the voltage is less than 4.8 VDC, a second 5 volt supply should be installed near the CPU module.

The small ribbon cable supplied with the display module is used for connecting the display module to the CPU module. Route this cable away from other wiring. This ribbon cable must never be routed in the panel duct which includes other wiring. Route this cable outside of the duct. Make sure the ferrite clamp is on this cable and installed closest to the CPU module.

Connect the ribbon cable to its 14 pin mating connector located through the cutout in the CPU module's metal base. Do not force this connector into the 16 pin connector located on the upper circuit board.

Due to the wide range of available options, it is virtually impossible to provide a dedicated wiring diagram for each combination. Therefore, we have provided one typical diagram covering all connections to a common single-turn resolver system. We then follow this with a series of diagrams divided into categories covering standard inputs, standard outputs, auxiliary outputs and special purpose options. Review

**WIRING
INSTRUCTIONS
CONT'D.**

the part number of your specific system with the part number descriptor sheet provided with your equipment or the part number development page in catalog section 1989 to verify the options it includes. Next select the appropriate input and output wiring diagram based on your systems part number. Auxiliary outputs

are then wired per the appropriate diagram. When doing all wiring, the terminal strip designations on your CPU module should be followed if they differ from the diagrams in this manual. Some unusual variations or combinations of options may result in the relocation of some of the special purpose option terminals.

Wiring Diagram Reference Chart

Description	Diagram Number	Page
General wiring diagram single-turn resolver system	E-0190100-C	11-12
Inputs		
Multi-turn dual resolver	E-0210900-A	13
Type 950CP linear transducer	E-0210700-A	14
Type 950 A linear transducer	E-0210800-A	14
Binary input	E-0211500-B	*
Analog input	E-0211600-B	*
Standard outputs		
Low-power outputs from CPU module wired directly to PLC input card	E-0193302-A	15
High-power relay output modules wired to loads	E-0193301-A	16
Auxiliary outputs		
Optional analog output, remote display and RS232/RS485 communications output board	E-0205000-B	17
Brake monitor input and output wiring	E-0205100-B	17
Fault check inputs and outputs and reset to preset input	E-0211700-B	18
Auxiliary digital outputs	E-0214900-B	18
Auxiliary 32 and 48 limit switch output wiring	E-0215000-B	19
Internal resolver wiring		
Single-turn resolver	E-0177100-C	20
Multi-turn dual resolver	E-0184600-C	20
*Supplementary diagrams not included in this manual.		

Note: All of the diagrams in this manual are available as larger full-size prints. Contact the factory and specify by diagram number if copies are required.



INSTALLATION

General Wiring Diagram Diagram E-0190100-C

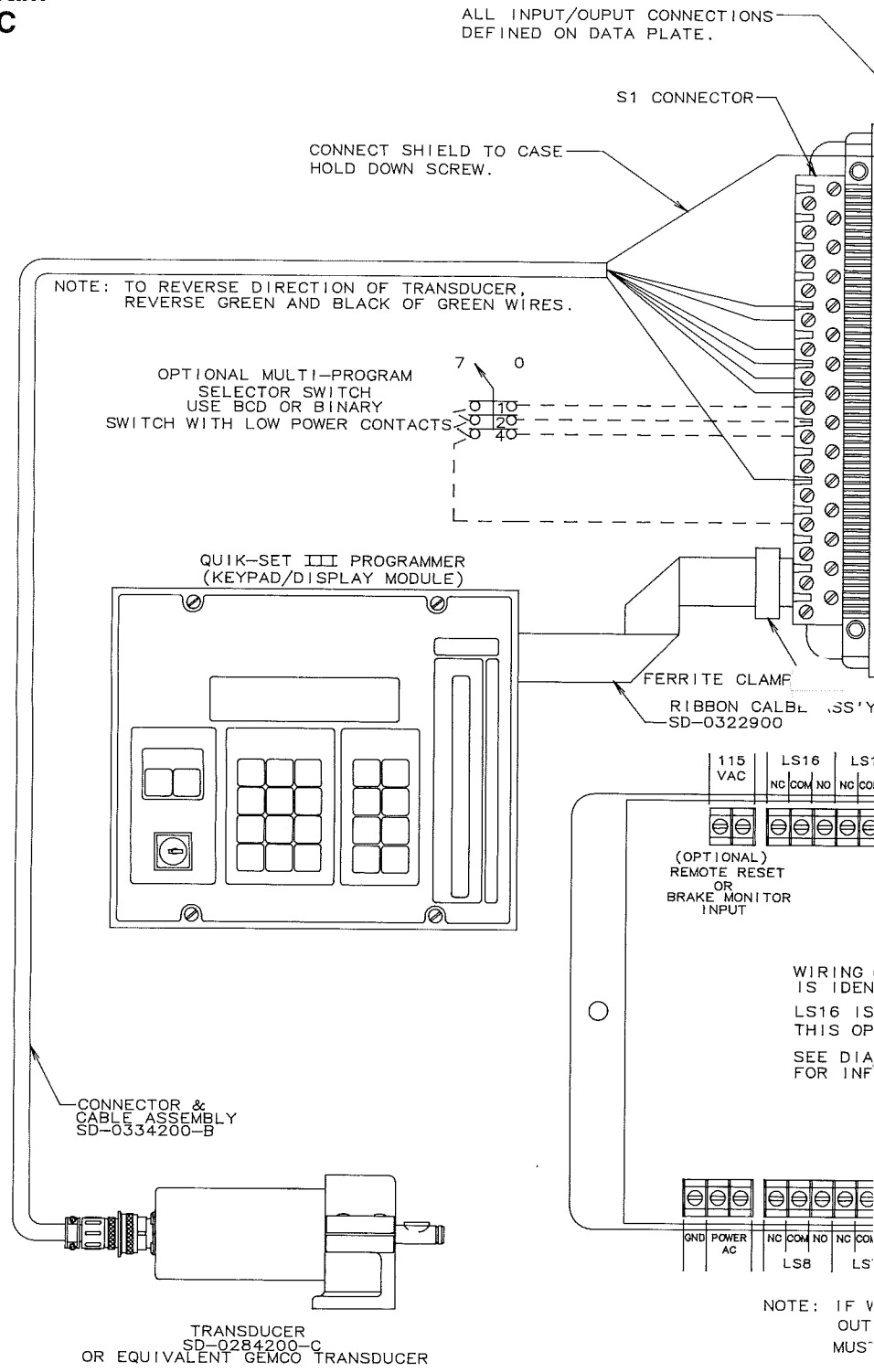

IF CABLE LENGTHS PROVIDED ARE LONGER THAN REQUIRED, IT IS RECOMMENDED THAT THE CABLE(S) BE SHORTENED AND RE-INSTALLED IN THE S1 AND S2 CONNECTORS.



INSTALLATION

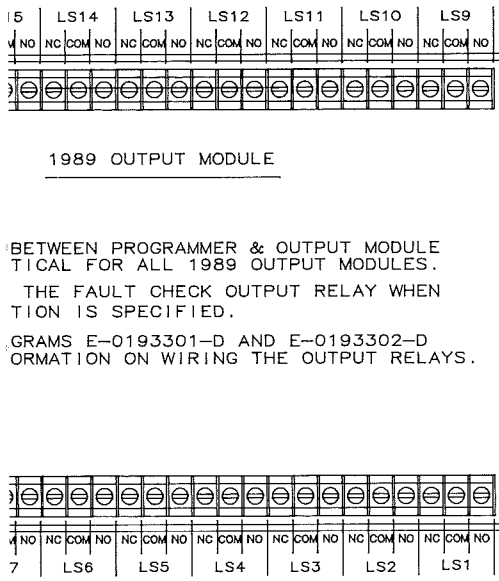
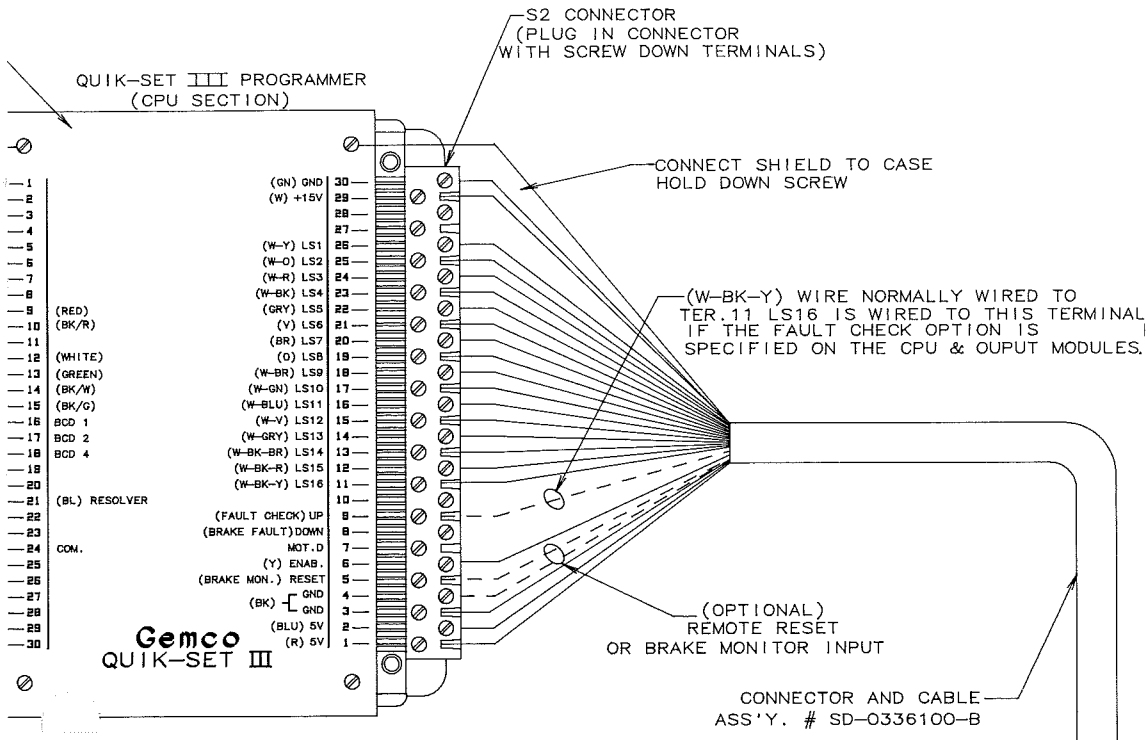

WIRING PER THIS DIAGRAM THE OUTPUT OF THE "1989" PROGRAMMER (CPU SECTION) MUST BE CURRENT SINKING.

INSTALLATION

Multiturn Dual Resolver Input
Diagram E-0210900-A

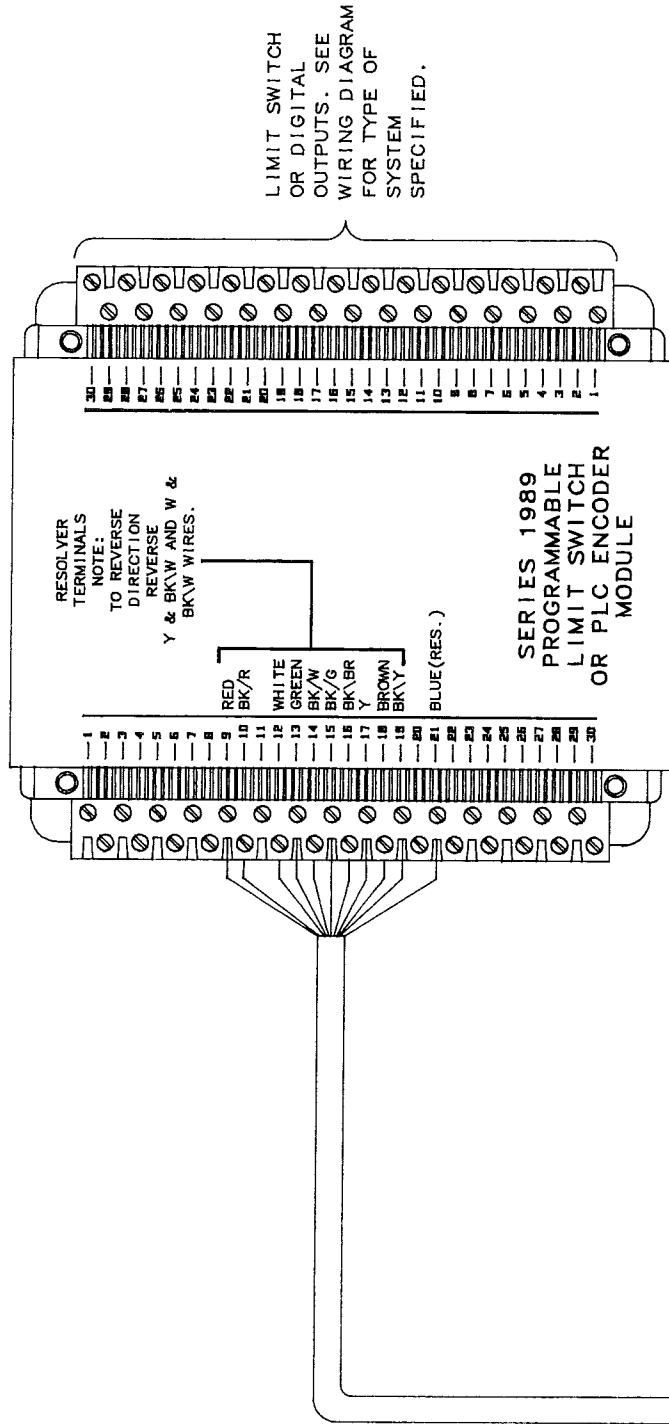

WIRING OF MULTITURN DUAL RESOLVER
ASSEMBLY TO SERIES 1989 PROGRAMMABLE
LIMIT SWITCH

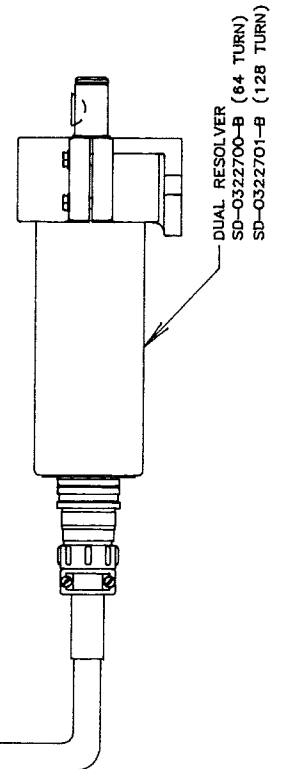



INSTALLATION

**Series 950CP Linear Transducer Input
Diagram E-0210700-A**

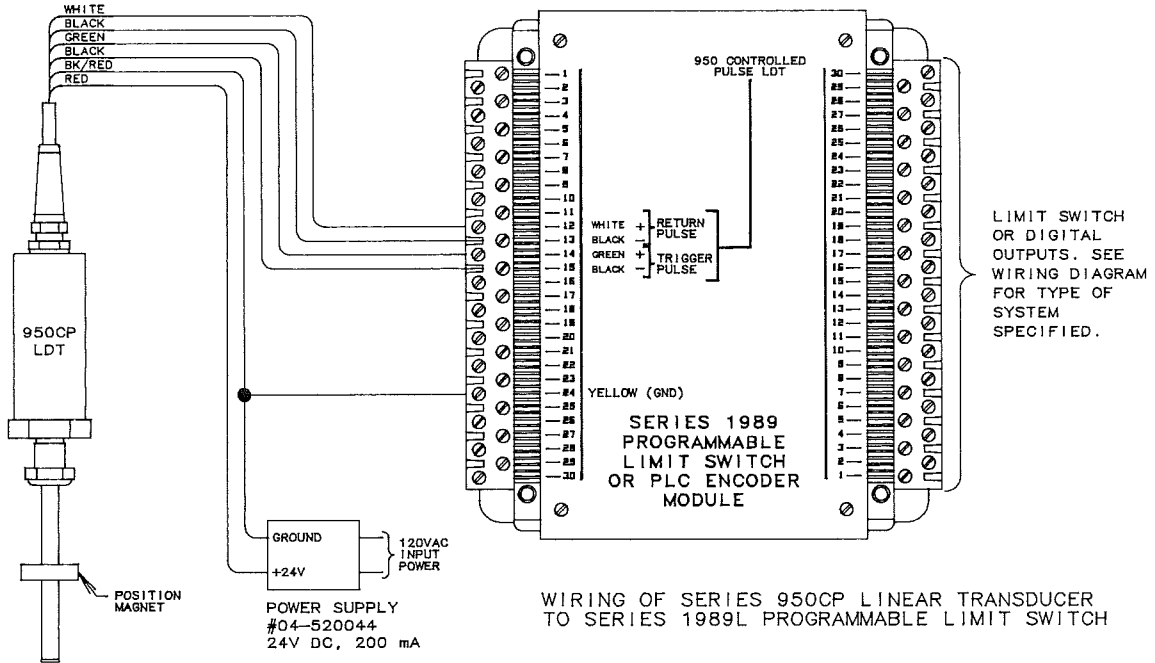

**Series 950A Linear Transducer Input
Diagram E-0210800-A**

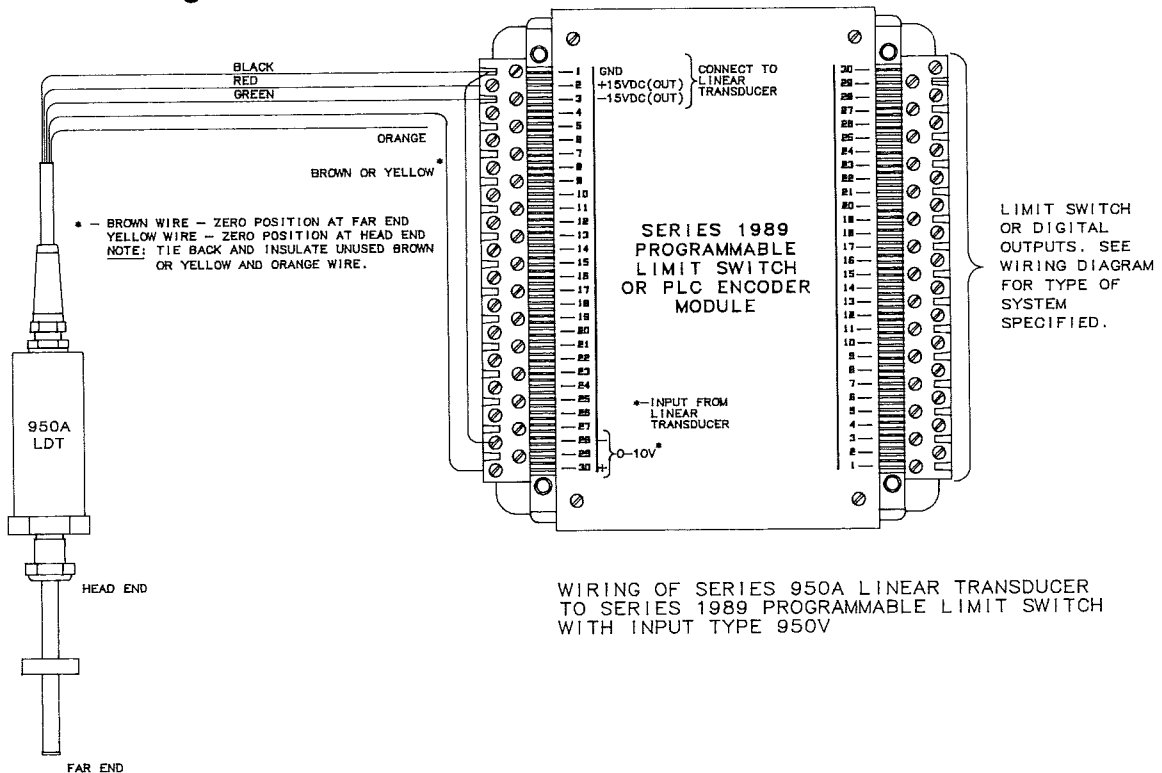

**Low Power Outputs from CPU Module
Wired Directly to PLC Input Card
Diagram E-0193302-A**

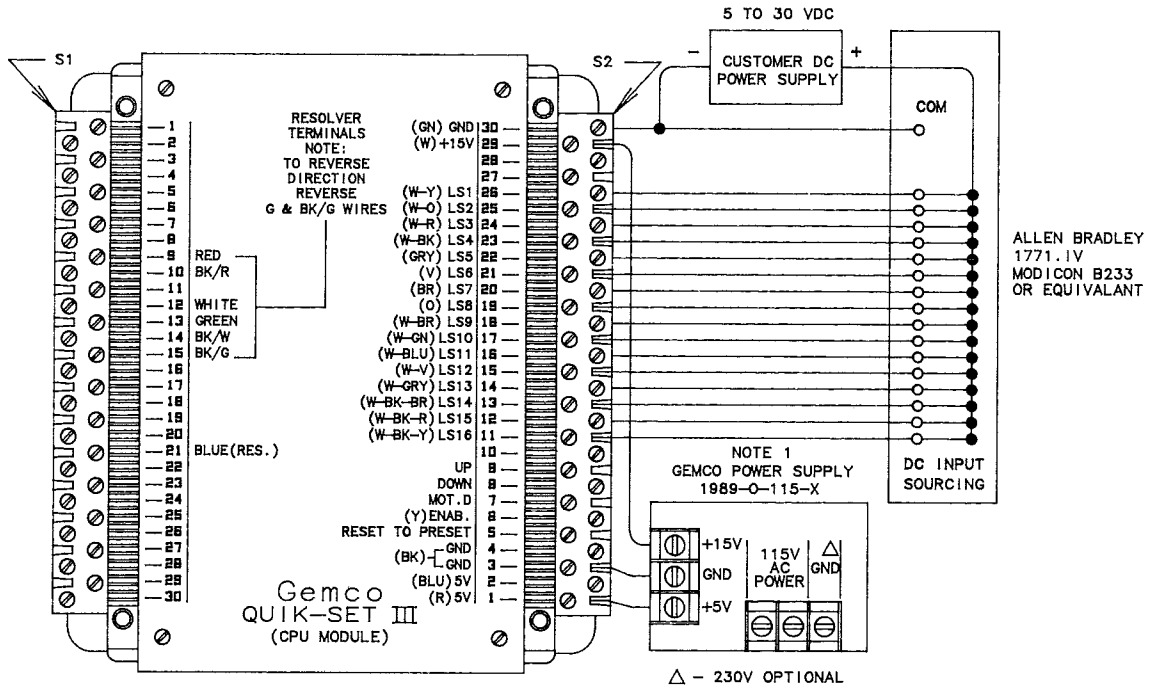

NOTE 2
SINKING P.L.C. INPUT - USE GEMCO CURRENT SOURCING OUTPUT (OPTION C)

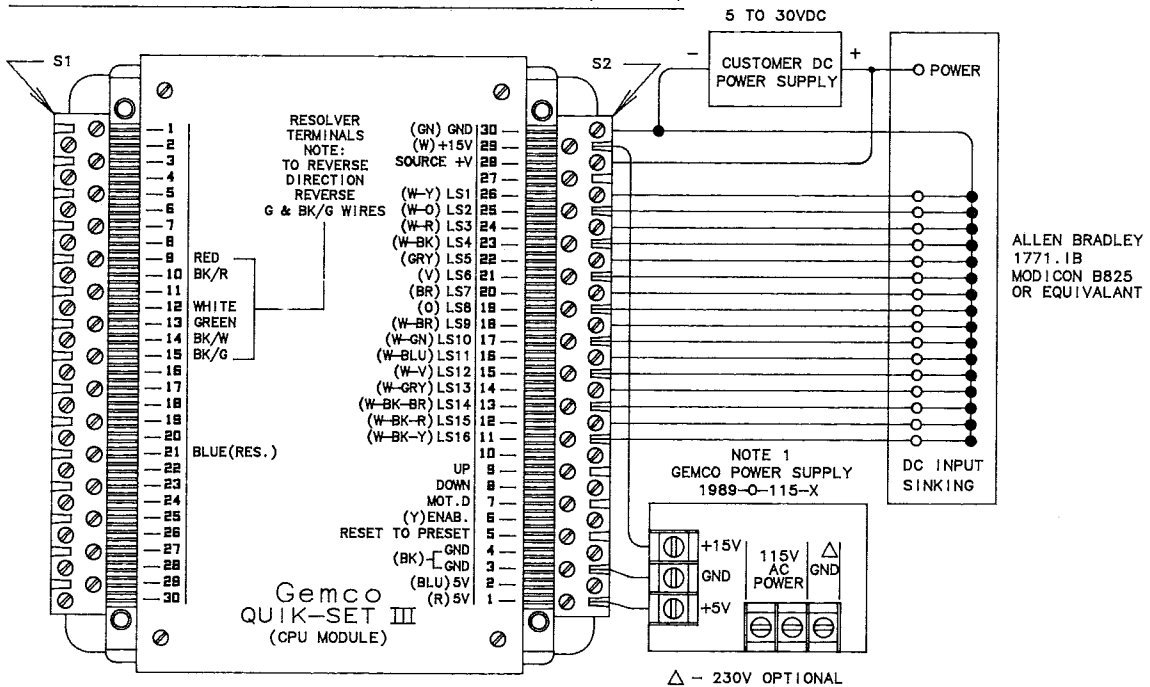



INSTALLATION

High Power Relay Output Modules Wired to Loads Diagram E-0193301-A

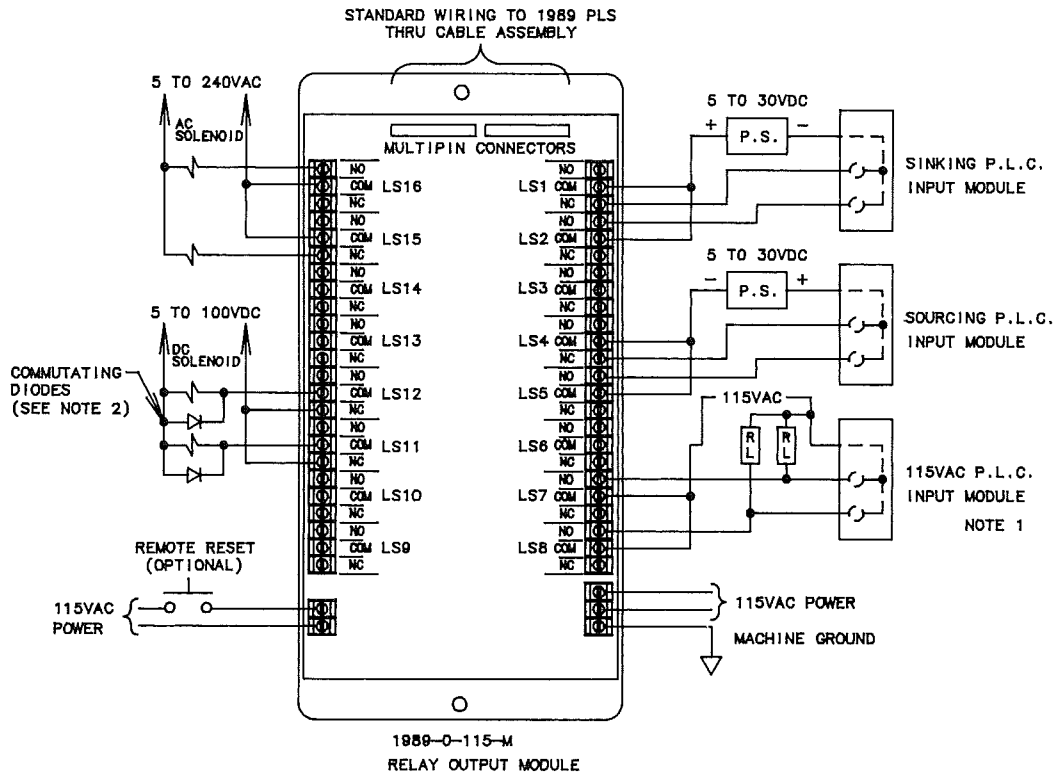

NOTES:

- 1) REMOVE SNUBBER CIRCUIT RESISTOR (R1 FOR N.O.; R2 FOR N.C.) ON APPROPRIATE LS OUTPUT OR ADD R_L LOAD RESISTOR (18K - 2W) WHEN OPERATING 115VAC P.L.C. INPUT MODULE LEAKAGE THRU SNUBBER CIRCUIT MAY KEEP P.L.C. INPUT ON.
- 2) WHEN USING THE OPEN COLLECTOR OR RELAY OUTPUT TO ENERGIZE A D.C. INDUCTIVE DEVICE SUCH AS A D.C. SOLENOID, A COMMUTATING DIODE MUST BE INSTALLED ACROSS THE DEVICE TO ELIMINATE HIGH VOLTAGE SPIKES.

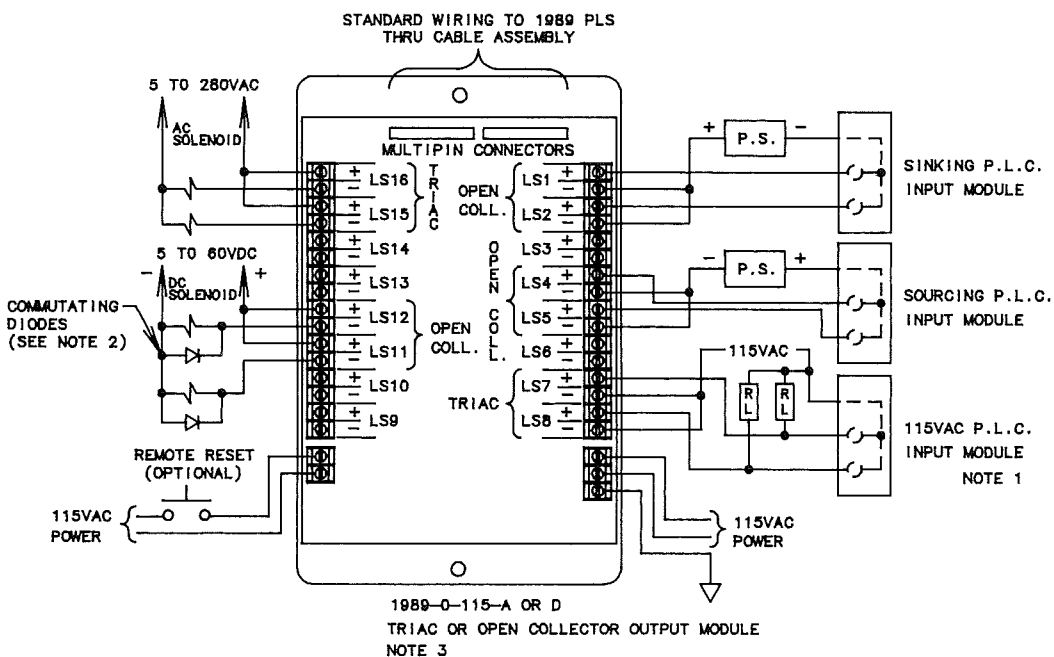

- 3) TERMINAL POLARITY (+ -) MUST BE MAINTAINED WHEN USING THE OPEN COLLECTOR OUTPUT. POLARITY NOT SIGNIFICANT WHEN USING TRIAC OUTPUT. OUTPUT TYPES MAY BE MIXED ON THIS MODULE.
- 4) WHEN USING 1989 OUTPUT MODULES, THE PROGRAMMER CURRENT SINKING OUTPUT (OPTION E) MUST BE USED. IF DESIRED, THE CPU MODULE OUTPUTS MAY SELECTIVELY BE USED TO DIRECTLY OPERATE A SOURCING P.L.C. INPUT. SEE DIAG. E-0193302-A FOR DETAILS.



INSTALLATION

Brake Monitor - Option S Diagram E-0205100-B

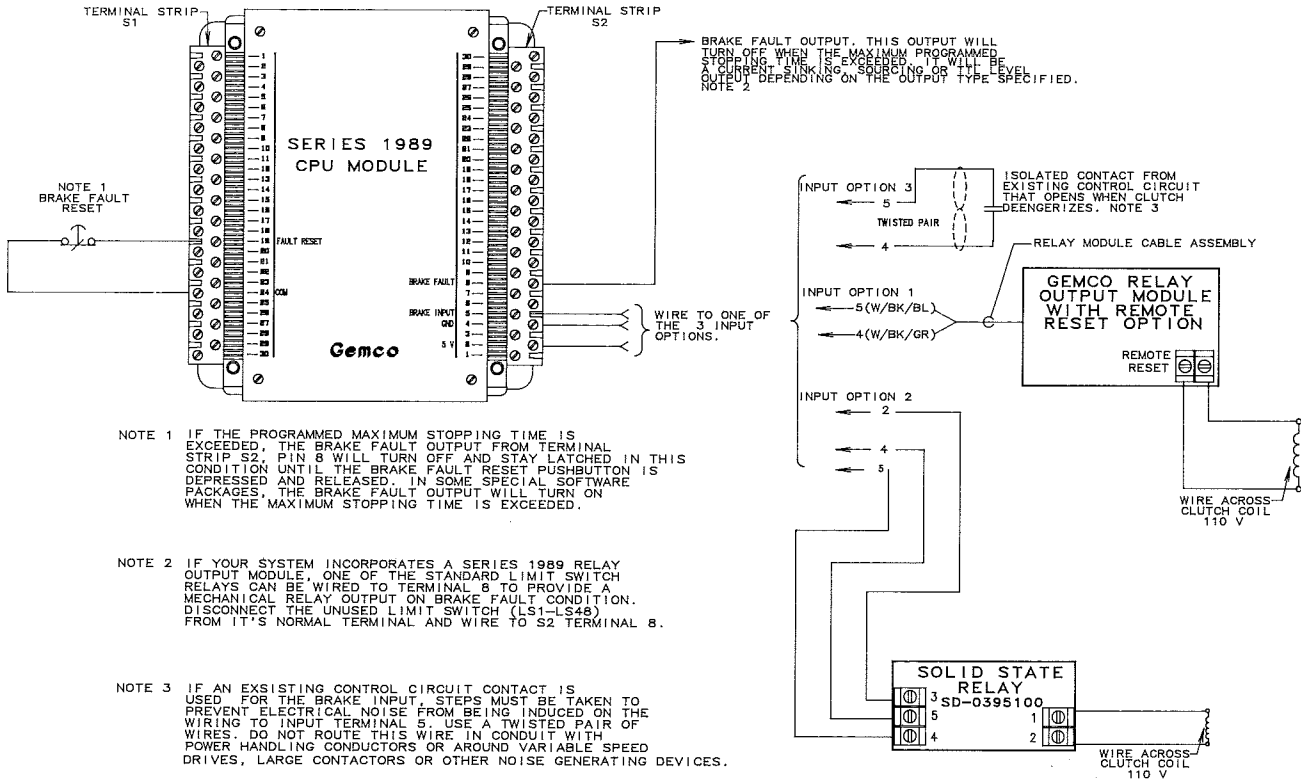

Optional Output Board - Options A, H and R Diagram E-0205000-B

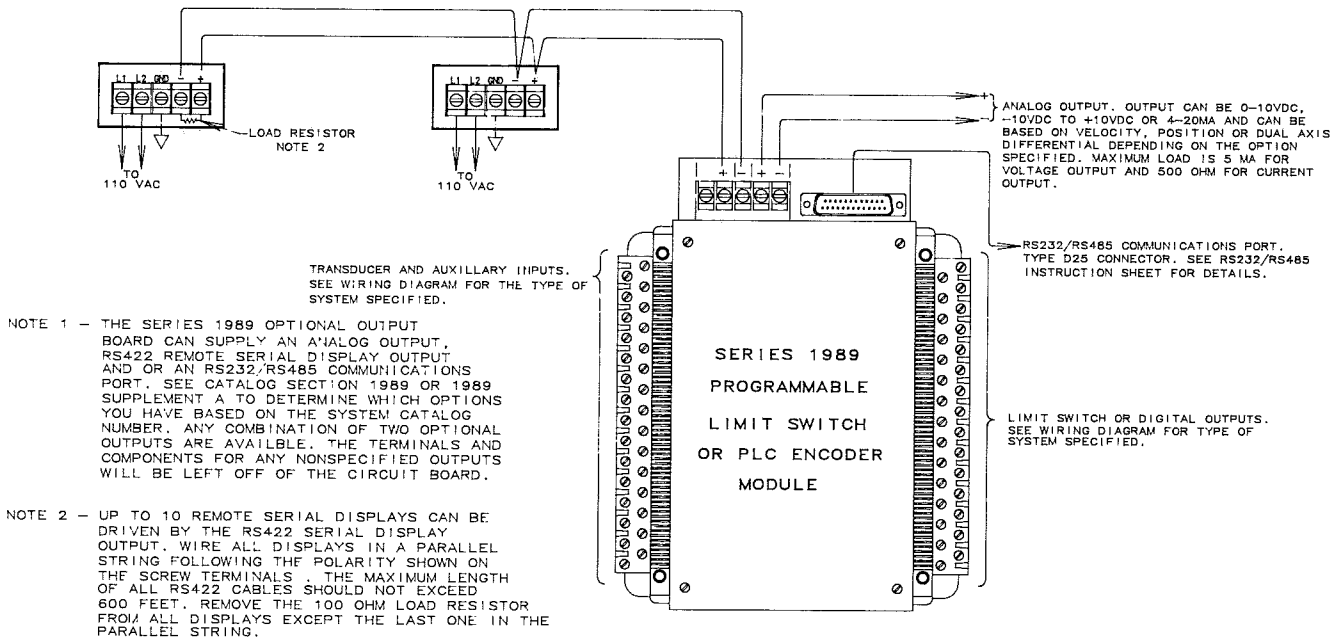



INSTALLATION

Fault Check Inputs and Outputs and Reset to Preset Input Diagram E-0211700-B

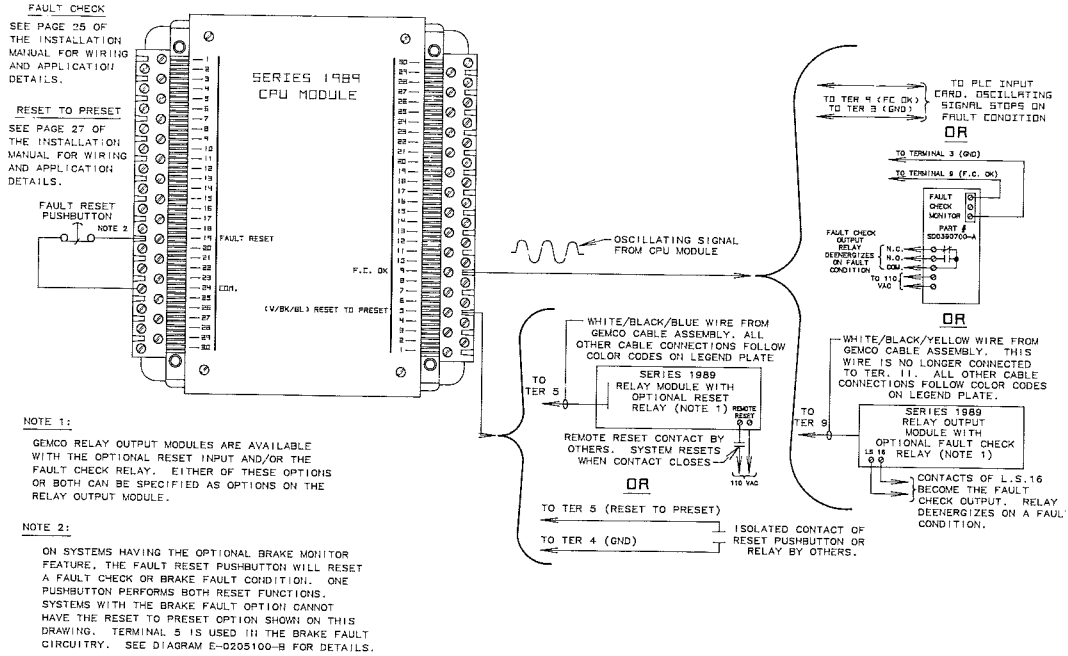

Auxiliary Digital Outputs Diagram E-0214900-B

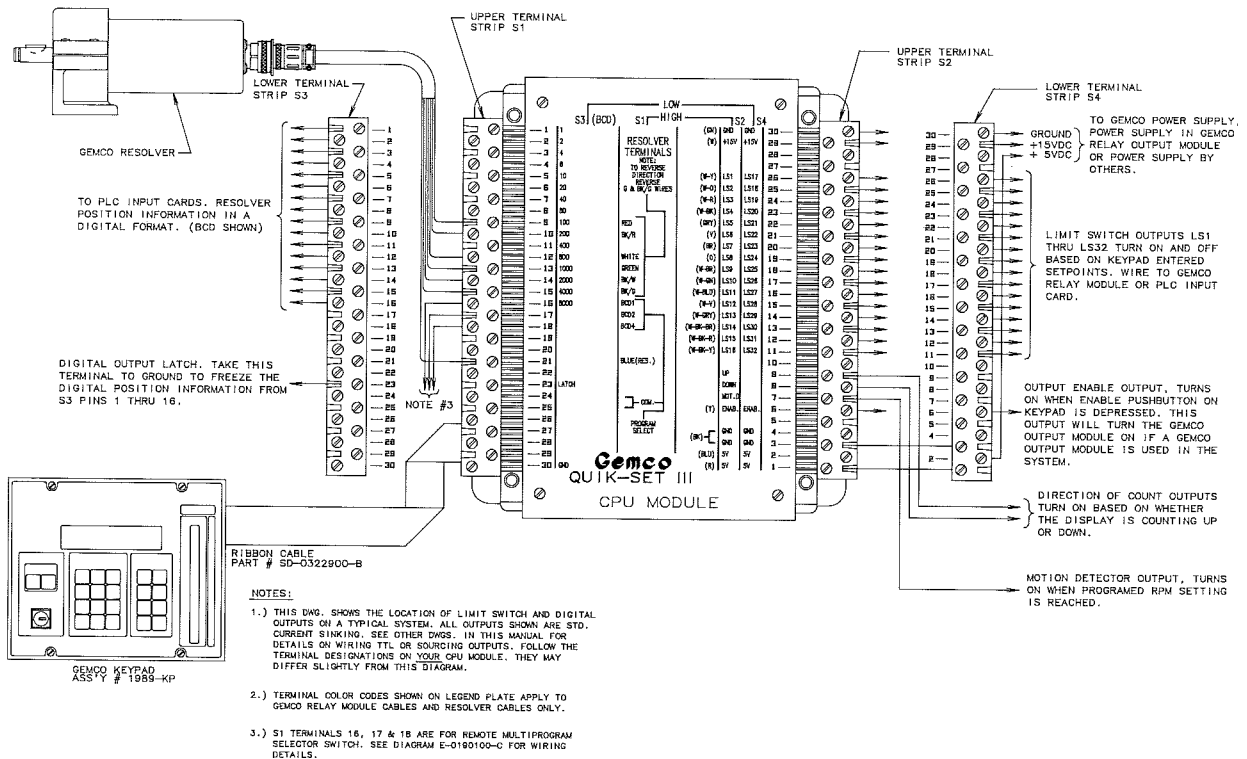

Typical wiring of 32 and 48 Limit Switch Outputs Diagram E-0215000-B

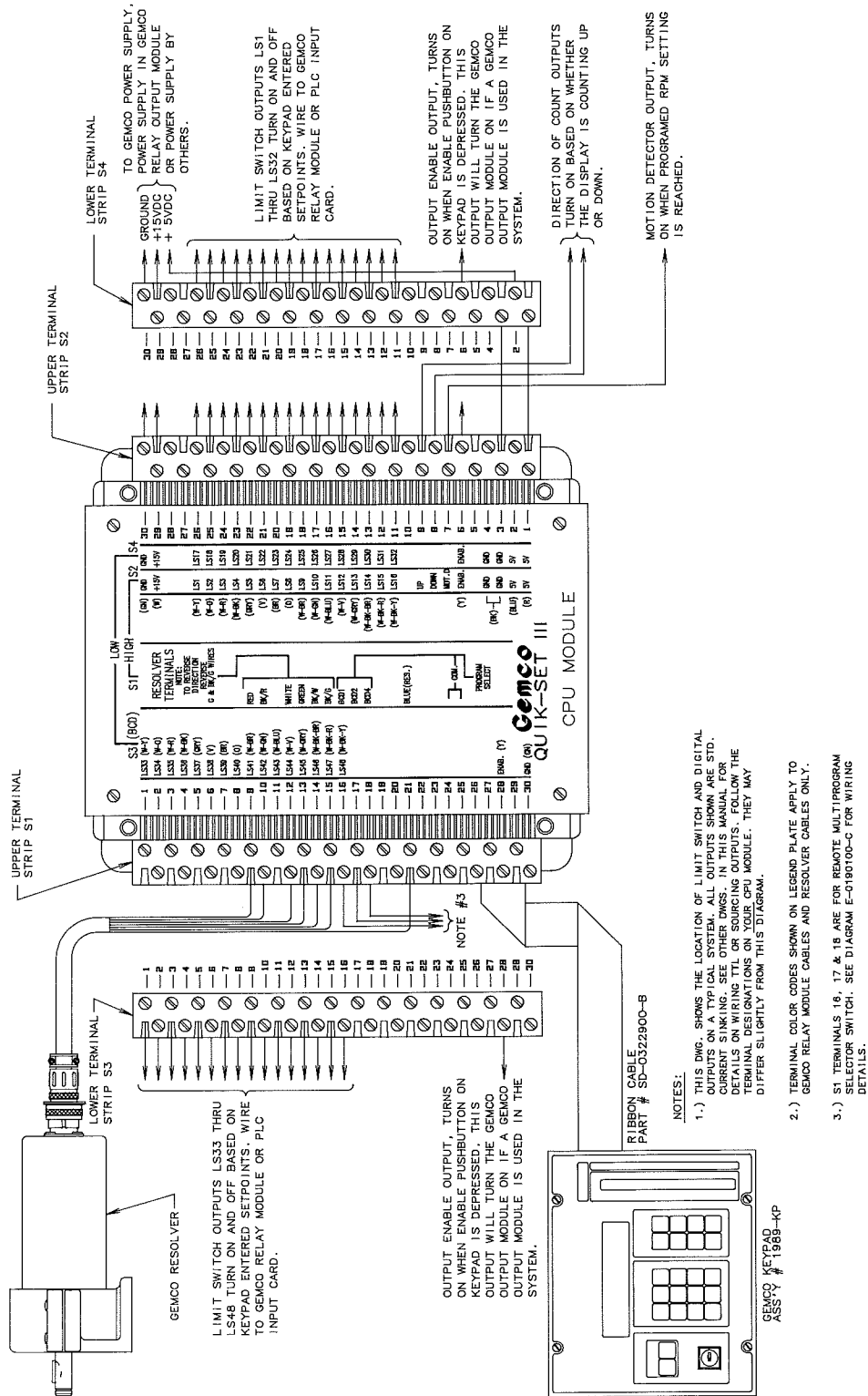



INSTALLATION

Transducer to Controller - Single Resolver Diagram E-0117100-C

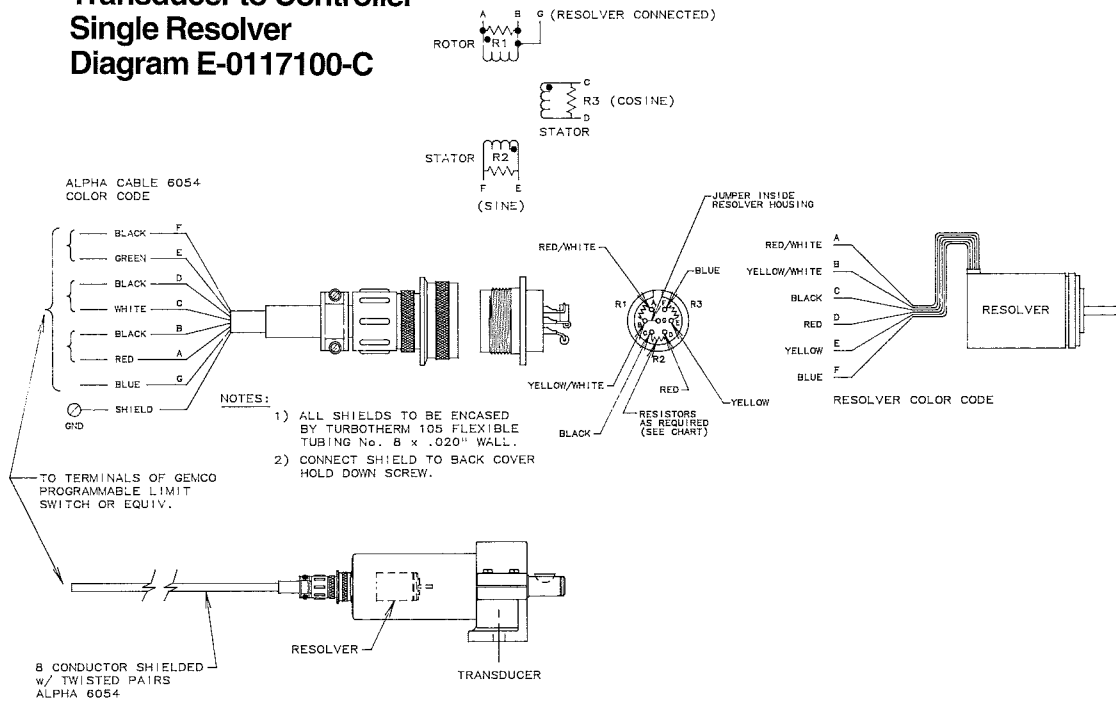

Transducer to Controller - Dual Resolver Diagram E-0184600-C

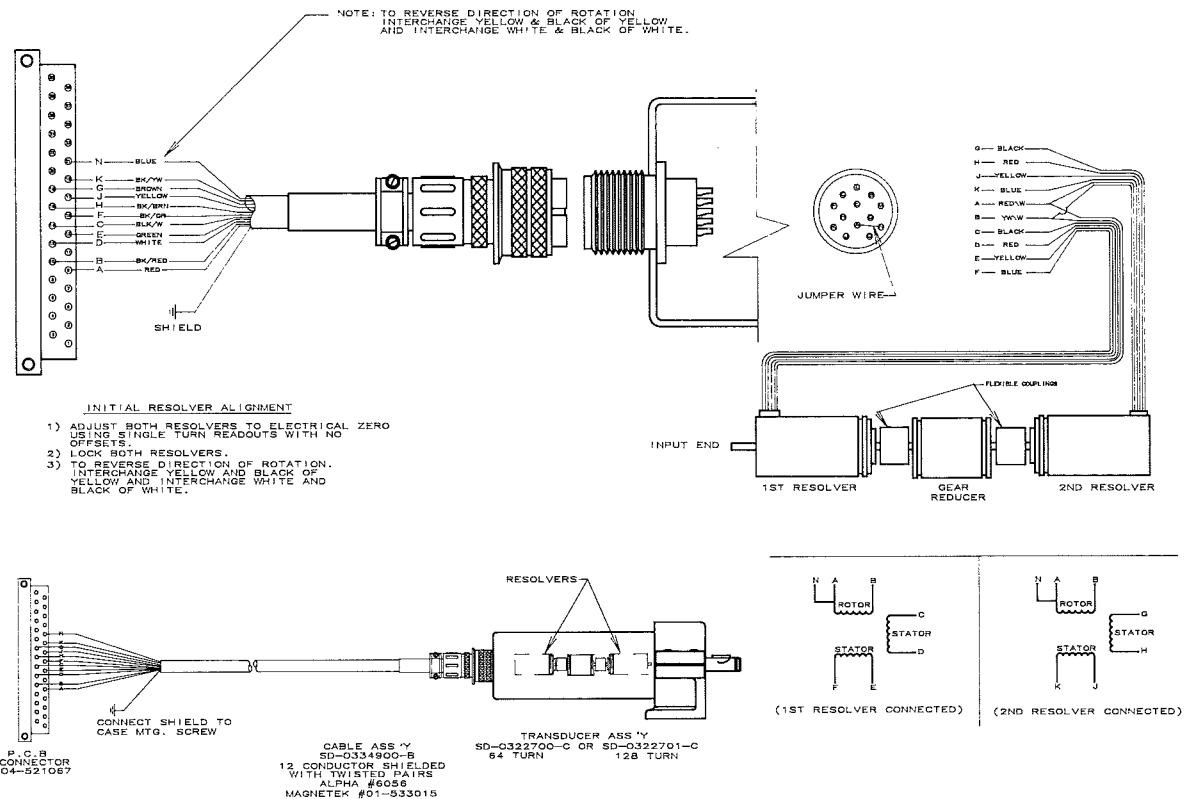

IV.

SPECIFICATIONS

QUIK-SET III PROGRAMMER (DISPLAY AND CPU MODULE)	Resolution	Up to 24 Bit from binary encoder Up to 21 Bit with dual resolver
	Scale Factor Range	12 or 14 Bit 2-99999 (per turn)
	Temperature Range	Operating 32°F to 125°F Storage 0°F to 150°F
	Motion Detector	Standard response time 29 milli-seconds
	Scan Time	Standard 200 micro-seconds (65 and 17 micro-second scan times available, consult factory for details)
	Total Set Points	16 Circuit, Single-program, 100; 32 or 48 Circuit, Single-program, 128 16 Circuit, Multi-program, 65/Program; 32 Circuit, Multi-program, 90/Program 48 Circuit, Multi-program, 120/Program

CPU MODULE OUTPUT TYPES	Current Sinking	Sprague ULN 2803A, 5 to 50V, 0 to 200 ma, low true (on). Cannot be used to drive TTL circuit (use with high-power output modules).
	Current Sourcing	Sprague UDN 2981A, 5 to 50V, 0 to 200 ma, high true (on). Cannot be used to drive TTL circuit.
	TTL	Sinking current (74LS173) up to 20 ma, high true (on).

AUXILIARY OUTPUTS	BCD, Binary or Gray Code Outputs	Current sinking, current sourcing or TTL same as above CPU module outputs but customer-programmable for High = True or Low = True operation.
	Analog Voltage	0 to 10V or -10 to +10V at 5 ma
	Analog Current	4 to 20 ma, 500 OHM load maximum
	Fault Check	Oscillating output having same electrical characteristics as specified on CPU module. Use Gemco fault check relay if contact output is required.
	RS-232 or RS-485 Communications Transceiver	Use with any RS-232 or RS-485 compatible device
	Remote Display Transmitter	Use with Gemco remote displays only
	Motion Detect	Same output type as selected CPU module output

HIGH POWER OUTPUT MODULES	Mechanical Relay Output Module	
	Input Voltage	115 VAC (optional 230 VAC) \pm 10% (22 VA)
	Output Voltage to CPU module	5/15 VDC
	Output Type #16Q2C-D024	16 Mechanical SPDT 10 Amp isolated contact relays, pick-up 2 ms; drop-out 15 ms
	P.C. Interface Output Module	
	Input Voltage	115 VAC (optional 230 VAC) \pm 10% (15 VA)
	Output Voltage to Programmer	5/15 VDC
	Output Type - TIL 119	16 optically isolated, Darlington sink or source, 100 ma, 1-30 VDC open collector, 0.1 ms On; 0.5 ms Off, leakage 0.1 ma
	Solid State Triac Output Module	
	Input Voltage	115 VAC (optional 230 VAC) \pm 10% (15 VA)
	Output Voltage to Programmer	5/15 VDC
	Output Type - OAC-24	16 Triac, 3 Amp, 280 VAC maximum, zero crossing 0-8 ms On; 0-8 ms Off, leakage 5ma @ 280 VAC
	Solid State Open Collector Output Module	
	Input Voltage	115 VAC (optional 230 VAC) \pm 10% (15 VA)
	Output Voltage to Programmer	5/15 VDC
Output Type - ODC-24	16 optically isolated, sink or source, 3 Amp, 60 VDC open collector, 0.1 ms On; 0.75 ms Off, leakage 1 ma @ 60 VDC	

Note: Programming of the scale factor will delete all programmed data held in memory. Therefore, it should be the first step in your set-up procedures.

KEYBOARD FUNCTIONS

Run/Prog selector

The key selector in the lower left hand corner of the keypad prevents unauthorized changes to the programmed functions. With the key in the program (PROG) mode, all functions of the controller can be programmed. With the key in the RUN mode, all set points, scale factor, decimal point, offset, motion detection, and other optional functions can be verified, but the programmed information cannot be changed.

Circuit on/off commands

On a standard 16 circuit programmer, the outputs of circuits LS1-LS16 can be programmed to turn on or off by pressing the appropriate key. An output status LED lights when the outputs are called for. All outputs are enabled when the key selector is turned to the RUN mode. The enable/disable key does not function unless the key lock is in the PROG mode.

The 16 output status LED's illuminate to indicate that the output has turned ON. When the status of outputs 1-16 are being monitored by the LED's, the letter L is displayed on the left side of the digital display. On 32 or 48 circuit units, the letter H or E will be displayed to indicate that the output status LED's are monitoring the status of circuits 17-32 (H) or 33-48 (E). To monitor the status of a particular group of outputs, call up any circuit in that group using the keypad sequences described below under "selecting a circuit for programming."

An L, H or E will be displayed to indicate that the output status LED's are monitoring the status of that

particular group of outputs.

The output status LED's indicate the actual status of the low-power outputs in the CPU module. If a Gemco high-power output module is used in the system, the corresponding high-power output relay will be turning on and off with the status output LED's. This only occurs when the enable/disable key has been enabled.

Enable/disable key

When the enable/disable keys are pressed, the low-power output labeled "enable" on the CPU module will activate. If your system includes a Gemco high-power output module, the output module will be enabled or disabled by pressing these keys. These keys do not affect the low-power LS outputs from the CPU module. If these outputs are being fed directly to a PLC, you must remember that the enable/disable keys will have no effect on the output signals seen by the PLC. The output from the enable terminal of the Gemco CPU module could be used as an input to the PLC and your software could be written to use this input to enable or disable the PLC outputs.

The enable/disable keys will only function when the PROG/RUN selector is in the PROG position. The outputs are automatically enabled when the selector is put in the RUN position.

This feature allows the PLS to be programmed and the outputs to be verified prior to turning the control of the machine over to the PLS outputs.

SCALE FACTOR PROGRAMMING

Insert the key in the Prog/Run key switch, turn to the PROG position. Press the "disable" key. This turns off the "enable" LED on the output module and disables the higher power relays.

Prior to programming-only - determine whether your system is a single program or multi-program unit. Then, enter the following key commands to clear any existing programmed data:

CIR#, 9, 1, ENT - For single program units

CIR#, 3, 9, 1, ENT - For multi-program units

The display will go blank for a few seconds while the programmer is clearing all memory. When the display is operating again, enter the scale factor.

To calculate a scale factor:

The scale factor is the maximum number that the PLS will count to over the full output range of the transducer. Follow the instructions for the transducer used in your system.

A single-turn resolver provides absolute position data over one turn of its input shaft before repeating. On rotary applications, a scale factor of 360 or 3600 will provide position data in degrees or 1/10 of a degree. If one revolution of the resolver shaft

represents a linear machine stroke, a scale factor can be selected that provides position data in linear engineering units appropriate for the application. Example: A single-turn resolver is rack and pinion driven so that the resolver makes one complete revolution over 18.80 inches of machine stroke. A scale factor of 1880 would provide position data and the programming of set points to 1/100 of an inch.

Gemco does manufacture resolver packages consisting of a single-turn resolver with an internal precision gear reducer. The effect of this gear ratio must be considered when calculating the scale factor for this type of transducer.

Multi-turn dual resolvers are special transducers consisting of 2 resolvers coupled together through an internal 64 or 128:1 precision gear reducer. The front resolver provides fine position data for each turn of the input shaft while the rear resolver keeps track of the number of turns. These devices will provide absolute position data over 64 or 128 turns of the input shaft before repeating. The scale factor for a dual resolver is calculated based on the distance traveled over one turn of its input shaft.

Example: If one revolution represents 120 inches

of travel, a scale factor of 1200 will provide position data and set point programming in inches to 1/10 of an inch. The 1989 PLS would count from zero to 1200 over the first revolution of the input shaft and continue counting up from there, adding 1200 to the total for each subsequent turn. It will continue to count up for 64 or 128 turns before starting over at zero.

Absolute optical encoders and other binary input devices have a specific maximum output rating. Their maximum binary output number must be matched to the input capabilities of the 1989 PLS. As outlined above, the scale factor can be any number that represents the amount of machine movement that results in the full binary count of the encoder.

Example: An absolute optical encoder provides a 12 bit (4096) binary output to the 1989 PLS. This zero to 4095 count represents one rotation of a rotary machine. A scale factor of 360 or 3600 will convert this input to provide position data and programming in degrees or 1/10 of a degree.

Example: A 10 turn absolute optical encoder provides a 14 bit (16384) binary output to a 1989 PLS. The zero to 16383 output represents 120 feet of machine travel. A scale factor of 12000 would provide position data to 1/100 of an inch.

The series 950CP LDT is provided with a specific scale factor printed on its can assembly. For maximum accuracy and resolution, this scale factor should be used. Insure that 1989 PLS input converter is properly matched to the scale factor printed on the 950CP LDT.

Analog output transducers, including the series 950A analog LDT, will provide a 0-10 VDC or 4-20 ma output over their rated operating stroke. The amount of machine travel represented by the full swing of the analog output should be used as the scale factor.

Example: A series 950A analog LDT generates its 0-10 VDC output over an active stroke of 1500 mm. A scale factor of 1500 will provide position data and the programming of set points in 1 mm increments.

If the analog output transducer generates its full scale output based on some other parameter like pressure or temperature, the 1989 PLS can be scaled to allow the programming of set points in these units.

Example: A pressure switch generates a 4-20 ma output over a pressure range of 0-2000 psi. A scale factor of 2000 would provide a readout and allow set points to be programmed in pounds per square inch.

To enter a new scale factor:

1. With the display in the PROG mode, press POS and enter the scale factor.
2. Press the scale factor button located on the back of the module near the ribbon cable connector. The display will blank and return to the current position of the transducer. The new scale factor will remain in effect until another is entered.
3. To check the existing scale factor, press the scale factor button only.

Next, turn the transducer shaft to determine the direction of rotation. If the LCD readout on the module decreases as the position of rotation increases, the direction of rotation may be reversed on single-turn resolvers by interchanging the green and black of green wires from the transducer at the CPU module. For reversing a dual resolver, interchange the white and black of white and yellow and black of yellow. For other transducers, contact the transducer manufacturer.

It is recommended the 0° "start cycle position" of the machine be determined and the resolver be mechanically zeroed by loosening the four bolt heads on the mounting foot and rotating the resolver until the display on the module reads zero. The bolts should then be retightened and additional adjustments made using the offset programming function below.

DECIMAL POINT PROGRAMMING

A continuous, non-floating decimal point may be programmed on the display. If a scale factor is selected that needs a decimal point in order to properly display its resolution in engineering units, the following 50 series codes are used:

- 50 - no decimal point, clears existing decimal point
- 51 - tenths
- 52 - hundredths
- 53 - thousandths

54 - ten thousandths
Insert the appropriate 50 series code in the following sequence:

CIR#, 50 series code, ENT

Example: A scale factor of 3600 has been selected for a rotary application to display degrees to a tenth of a degree. To program a decimal point in the tenths position press:

CIR#, 5, 1, ENT

OFFSET VALUE

The offset key is used to synchronize the digital display with actual machine position. The series 1989 PLS has full scale factor offset capabilities and the offset is held on nonvolatile memory. However, to eliminate possible problems should a replacement PLS be required, it is good practice to mechanically synchronize the resolver with the machine and then use the offset key to make final, fine adjustments. To use the offset key, the machine must be taken to a known position. The offset key is then pressed, followed by the known machine

position, then ENT.

Example 1: A machine is jogged to its home or zero position, but the PLS display is reading 12. To synchronize the PLS display with actual machine position, press:

OFS, 0, ENT

Example 2: An automated hoist system is stopped at elevation 200.0, but the PLS display is reading 196.7, press:

OFS, 2000, ENT

SET POINTS

Selecting a circuit for programming

For new or existing set points, first select the limit switch output you want to program. Do this by pressing the CIR# key, followed by the circuit number, followed by ENT. For example, to select circuit number 3 for programming press CIR#, 3, ENT.

Entering new set points

Each set point specifies the position at which the circuit is to be turned on or off. The set points must be entered using all digits to the right of the decimal place even if they are zeros. A new set point for the current circuit may be entered by pressing the "CIR ON" key, followed by the position, then ENT. OFF set points are programmed the same except that the "CIR OFF" key is pressed to begin the sequence.

Example: To program the selected circuit to turn on at 25 and off at 125, press:

CIR ON, 2, 5, ENT

CIR OFF, 1, 2, 5, ENT

Additional set points can be programmed on the selected circuits by continuing the above sequences.

If there is more than one set point on the circuit, all decimal points on the display will flash as a visual warning to the programmer that multiple set points are programmed for that circuit. To verify the set points press the "CIR ON" or "CIR OFF" key repeatedly to display all of the points currently held in that circuit's memory.

Note 1: Any ON set point without a corresponding OFF will cause the output to turn on and stay on through any higher number. Any OFF set point without a corresponding ON set point will cause the circuit to be on at any lower number and be off through any higher number. On rotary applications, the status of these single set point outputs will reverse as resolver position crosses zero. On linear applications, the use of this concept can simplify programming sequences where the output is intended to activate at a specific point and stay in that condition through all continued movement in the same direction. However, steps must be taken to insure that the resolver position cannot roll over through zero which would result in a reversal of the output's status.

Note 2: When all circuits have been programmed correctly, the display LED's will turn on and off as the transducer is turned through a complete

machine cycle.

Press the "enable" key to activate all output devices only after verifying the correct programming of the set points.

Modifying existing set pointsChanging a set point

The CHNG SET (Change Set) key is used to change the value of an existing set point. To use this key, first select a circuit. Press the "CIR ON" or "CIR OFF" key to display the set point to be modified. On circuits having multiple set points, the "CIR ON" or "CIR OFF" key is pressed repeatedly until the desired set point is displayed. The new value for the selected set point is now entered on the keypad, followed by CHNG SET. Upon pressing CHNG SET, the old set point value will be deleted and replaced with the new value. The conversion from one set point to another is completed during the first full scan of the software loop, which is generally 100-500 microseconds depending on the software options. This high speed capability allows fine tuning while the machine is in operation.

Example: To change an ON set point of circuit number 3 from 180 to 181 press:

CIR#, 3, ENT

"CIR ON" until 180 is displayed

1, 8, 1, CHNG SET

Deleting a set point

The CLR SET (Clear Set) key is used to delete an existing set point. To use this key, a circuit is first selected for programming. Press the "CIR ON" or "CIR OFF" key to display the set point to be deleted. With circuits having multiple set points, press the "CIR ON" or "CIR OFF" key repeatedly until the set point to be deleted is displayed. Press the CLR SET key to delete the set point.

Example: To delete the ON set point on circuit 1 which is currently set at 26 press:

CIR#, 1, ENT

"CIR ON" until 26 is displayed

CLR SET

The above sequence will delete the ON set point but has no effect on any corresponding OFF set point. Because most control functions consist of ON and OFF settings, you must remember to delete any corresponding set point to eliminate the type of operation described under Entering New Set Points; Note 1.

MOTION DETECTION

The motion detect output is used to provide an output based on the rotational velocity of the transducer. This output can be programmed to operate at any speed between 5 and 1000 RPM. Use the following sequence to program the motion detect RPM value:

1. Press RPM TACH key
2. Enter the RPM value at which the motion detect output is desired.
3. Press the red scale factor button located on the back of the keypad, near the ribbon cable connector.

To verify the programmed value, repeat the above steps, skipping step 2.

CAUTION: Display module must be in RPM mode when steps 2 and 3 are performed. If display is in POS mode when these steps are performed, you will have changed the scale factor and cleared all programmed limits and offsets.

Note: On systems having the selectable speed offset (option U) described on page 29, programming of a motion detect value will affect the speed offset circuits. Review minimum speed disable under option U.

VI.

ADVANCED FEATURES AND OPTIONS

Note: Advanced features and options are factory installed as original equipment. Check Part Number Descriptor Sheet for specific options that apply to your system.

PROGRAMMER OPTIONS

Option A - Analog Output

With this option, the PLS can control analog devices by creating an analog reference signal based on resolver or other PLS inputs. The analog output option is available in either 0 to 10 VDC, -10 to +10 VDC, or 4 to 20 milliamps. This option is keypad selectable to provide either Position or RPM (velocity) data and analog gain. This output is available from terminals on the auxiliary output board.

Typical applications include control of variable speed drives, feedback and control systems, valve positioning or data recording. Refer to wiring diagram E-0205000-B on page 17 for installation details.

To program the analog output to be based on RPM or Position, press:

CIR#, 2, 0, 2, ENT

The display will now show a 0 or 1 to indicate the mode currently selected. 0 = Position and 1 = RPM. To change, continue the sequence by pressing a 0 or 1 to select the desired mode, followed by ENT.

Example: To program the analog output to develop based on RPM, press:

CIR#, 2, 0, 2, ENT, 1, ENT

The low end of the analog output (0 to 10 VDC or 4 ma) will always be transmitted at 0 RPM or Position 0. The RPM or Position value at which the maximum analog output is transmitted is keypad programmable. To verify its current setting or change its value, press:

CIR#, 2, 0, 3, ENT

The display will now show the RPM or Position value at which the maximum analog output will be transmitted. To change, continue the above sequence by inserting the desired RPM or Position value, followed by ENT.

Example: To program a 4-20 ma output of RPM to develop over a range of 0-400 RPM, set the output mode to RPM by using the CIR# 202 code outlined above and then press:

CIR#, 2, 0, 3, ENT, 4, 0, ENT

The 4-20 ma output will now be 4 ma at 0 RPM and will climb to 20 ma as the RPM increases to 400 RPM.

Special software packages are available that allow programming the minimum analog value to something other than 0 RPM or Position 0. Consult the factory for details.

Option B - Digital Outputs

This option provides a parallel digital output for transmission of position or velocity data to a PLC input card. The output code can be BCD, binary or Gray code and is specified by the number inserted after the option designator B in the part number; B1 = BCD, B2 = binary, B3 = Gray. Gray code is generally used on high speed systems because only one bit changes for every digit transition. On standard systems having a field programmable scale factor the transition from the maximum scale factor count to zero may not be accomplished by one bit change. Special Excess Gray Codes are available if a unit with fixed scale factor is acceptable. Consult the factory for details.

The digital output is keypad selectable to provide either position or RPM output data. The parallel digital output is available at the terminal strip of the CPU module. The type of output used (i.e., current sinking, sourcing, TTL) is the same as the programmer limit switch output unless otherwise specified. This option is not available on systems having more than 32 circuits. The digital output is typically fed into a programmable controller in systems where high speed switching is performed by the PLS while slower speed functions are controlled by the PLC.

A latching input is provided to freeze the output data, thus allowing sufficient time for the PLC to reliably read the signal. However, if your system includes Fault Check the latch input is not available.

The latch is activated to freeze digital output data by taking the latch input pin low through an open collector output from the PLC. The output data will remain frozen as long as this input pin is held low.

Units are shipped factory-set to provide digital outputs based on position and a logic format of active = True. To verify the current setting of these parameters, press CIR#, followed by the access code, followed by ENT. The display will show a 0 or 1 to indicate the current mode of operation. To change, continue the sequence by inserting the appropriate number (0 or 1) followed by ENT.

To select Position or RPM data, press:

CIR#, 1, 6, 9, ENT, (0 or 1), ENT

- a. 0 selects Position data
- b. 1 selects RPM data

To select the logic format, press:

CIR#, 7, 5, ENT, (0 or 1), ENT

- a. 0 selects inactive (off) = True
- b. 1 selects active (on) = True

Option C - Fault Check

The fault check option provides an automatic in-process self-diagnostic mechanism to verify that all PLS functions are operating properly. The output from the fault check output terminal (terminal strip S2 pin 9) is an oscillating signal having the same electrical characteristics as the limit switch outputs (sinking, sourcing or TTL). When a fault condition is sensed this signal stops oscillating. This output can be fed into a PLC input card and software written to act upon the presence or absence of the oscillations.

If a hard contact is desired, the relay output module can be purchased with an optional fault check relay or a stand alone fault check relay module can be purchased.

If the relay output module is purchased with the fault check relay option, limit switch relay number 16 (LS16) will be modified to monitor the oscillating signal from the CPU module. The wire from the output module cable assembly that normally connects to terminal strip S2 pin 11, labeled LS16, will be rewired to terminal 9 labeled "Fault output." Relay number 16 of the output module cannot be used as a normal limit

VI.

ADVANCED FEATURES AND OPTIONS

PROGRAMMER OPTIONS CONT'D.

switch output if this option is specified. Any limit switch set points programmed on circuit number 16 will still result in low level ON/OFF outputs from the CPU module, but the high power relay on the relay output module will not be available for operation from this output due to its special fault check circuitry.

The stand-alone fault check relay module can be used on systems where all 16 limit switch output relays are required for limit switch functions or on systems where a relay output module is not being used. This module is wired to the fault check output terminal of the CPU module and provides a contact that opens when a fault condition exists. This module will only work on systems having current sinking or current sourcing outputs. See diagram E-0211700-B on page 18 for wiring details.

The fault check option will detect and disable system operation in the event of any of the following problems.

1. Disconnected or severed resolver cable
2. Resolver excitation failure
3. Resolver to digital convertor or associated electronic failure
4. Output module disabled
5. Output module to PLS cable disconnected
6. Loss of power to PLS (power supply failure, 115 VAC loss, blown fuse)
7. Microprocessor failure or lock-up

Non-system type faults, such as individual output failures, will not be sensed.

It is recommended that the fault check output be used as an "Operate Enable" type signal. Loss of this output should immediately stop the process which is being controlled.

A normally closed, momentary contact push button is wired between terminal strip S1, pins 19 and 24 to activate the fault check circuit and provide a method of resetting a fault output after the fault condition has been corrected.

To reset the fault check output after the fault condition has been cleared, the fault reset input must be de-activated (open circuit) and then re-actuated. Cycling the fault reset input will cycle the fault check relay to verify that the fault check output is operating properly.

Note: If the PLS system also incorporates the Brake Monitor (Option S), the fault check and brake fault reset button will be the same button. Actuation of this button will reset either a fault check or brake fault output. If this button is pressed to test the operation of either of these outputs, both outputs will indicate a fault condition.

PLS output status on fault conditions.

1. If the fault condition is a disconnected or severed resolver cable or resolver excitation failure, all limit switch outputs will turn off and the display will show all EEE's. If the fault condition is corrected, the limit switch outputs will resume normal operation but the fault check output will remain off and the display will continue to show all EEE's. The fault reset button must be pressed and released to reactivate the fault output and return the

display to normal operation.

2. If the fault condition is the result of a resolver to digital converter or associated electronic failure, the limit switch outputs will continue to operate, although possibly erratically. The fault check output will turn off and the display will show all EEE's. The fault condition must be corrected and the fault reset button pressed and released to resume normal operation.
3. If the fault condition is the result of a microprocessor failure or lock-up, the state of the limit switch output circuits cannot be predicted. However, the fault check output will turn off until the fault is cleared and the fault reset button is pressed and released. Removal and re-application of power to the PLS system may clear a locked-up condition.

Note: If an output module with fault check relay option is used, the enable/disable button on the keypad will disable the fault check relay when in the disable mode.

Option D - Differential Operation (Dual Axis Only)

The Differential option allows the system to monitor the difference in position or RPM between two axes in addition to normal dual axis limit switch operation.

Three outputs are also provided to indicate:

1. If axis 2 is greater than axis 1
2. If axis 2 is less than axis 1
3. If the two axes are in sync

This option offers keypad programming for linear or rotary differential position, as well as a differential dimension mode. In this mode, the PLS subtracts the two axis readings from a fixed overall dimension to measure overall width, such as slab width in a steel mill.

The analog output, when used with this option, can be keypad selected to monitor axis 1, axis 2, or the difference between the two in either position or RPM. The differential analog output can be used as a servo feedback device to synchronize the two axes.

Analog output voltage range will be 0 to +10 volts when monitoring differential position or RPM. Voltage gain and offset are keypad programmable. Refer to Supplementary Dual Axis Instruction Sheet for more details.

Option H - RS-232/485 Transceiver

The RS-232/485 Transceiver option is available from terminals on an auxiliary board of the CPU module. This transmitter/receiver allows programmer interrogation and remote programming of all keypad functions via a programmable controller or any ASCII CRT terminal via an RS-232 or RS-485 serial data link. This option is not available when Options A and R are both specified. See wiring diagram E-0205000-B on page 17 for installation details. Refer to Supplemental RS-232/485 Instruction Sheet for more details.

Option K - PLS Option

This standard option package incorporates all of the following options:

1. Option O - Remote Reset to Preset Value

VI.

ADVANCED FEATURES AND OPTIONS

PROGRAMMER OPTIONS CONT'D.

2. Option M - Multi-program (Keypad Select or BCD Input)
3. Option U - Selectable Speed Offset
4. Option C - Fault Check
5. Previous Option F - Selects Data Displayed at Power Up

Detailed descriptions and programming instructions can be found in this section under each of the specific options.

Option K also provides accommodations for the addition of an RS-232/RS-485 communications transceiver and/or a serial remote readout transmitter. This modification can be easily accomplished in the field with the addition of an electronic board to the CPU module of the programmer.

Option M - Multiple Program

Option M makes it possible to store eight separate operating programs with single or multiple dwells on up to 48 circuits simultaneously. This allows for rapid changeover from one set of manufacturing parameters to another without slowing production.

Program selection can be made by either a remote BCD switch input or through keypad selection. The display digit farthest to the left indicates which program is operating. Program selection via remote BCD input is not available with multi-turn resolvers or binary transducer inputs greater than 16 bits. Units are shipped factory set to multiple program selection via keypad entry.

The following initial keypad selection determines which mode of program selection is used. Press:

- CIR#, 375, ENT, 0 or 1, ENT
- a. 0 selects remote BCD switch input program selection
 - b. 1 selects keypad program selection

Program Selection through Keypad Entry - Program selection is made by keypad entry with the Program Key Switch in the PROG mode. To change programs, press:

CIR#, Program Code, ENT

The display will momentarily blank while the selected program is being initialized. When digits reappear on the display, the unit is ready to operate.

Prog. Num.	0	1	2	3	4	5	6	7
Prog. Code	770	771	772	773	774	775	776	777

When programming is complete, it is recommended that the Program Key Switch be returned to the RUN position and the key removed to eliminate any possibility of unauthorized data being entered.

Program Selection through Remote BCD Switch Input - A BCD input (0 to 7) is applied to 4 terminals (3 signals and common) on the CPU module of the PLS, to select the desired operating program. The BCD switch must be able to sink 15 VDC at 20 ma to the common to select programs, High = 1 (contact open).

Input	000	001	010	011	100	101	110	111
Prog. Num.	0	1	2	3	4	5	6	7

To clear all set points in the operating program while in the PROG mode press:

CIR#, 91, ENT

To clear all set points from all programs while in the PROG mode press:

CIR#, 391, ENT

Option O - Remote Reset to Preset Value

This option allows the position of the PLS to be reset to a keypad selected value based on an input from a remote contact or proximity switch mounted at a known location on the machine. Typical uses include compensation for slippage of idler wheel-driven resolvers, cable stretch, gear train backlash and to synchronize outputs with the leading edge of products moving through a machine.

The PLS position will reset to the selected value within 200 microseconds of seeing the leading edge of the contact closure input wired between the CPU module reset input terminal (terminal strip S2 terminal 5) and ground. This input terminal carries a computer level signal that should not be routed through a noisy electrical environment to a remote location on the machine. Review general wiring diagram E-0190100-C on pages 11-12 and note that the Gemco relay output modules can be ordered with a remote reset relay. This option allows a 110 VAC input from a remote switch to be wired to terminals on the output module. Upon seeing this 110 VAC input, a solid state relay on the output module energizes to provide the contact closure input to the CPU module.

Any standard control relay can be used for this same purpose. If the reset input is from a button, or other control relay, mounted near the CPU module, its contact can be wired directly to the input terminals if the wiring is routed to avoid electrical noise.

All recalculations of position due to this input are held in RAM and will be lost whenever power is interrupted. Therefore, it should only be used to compensate for minor changes in synchronization or in applications where loss of the reset value will not create a hazardous condition.

To program the remote reset to preset value, press:

CIR#, 1, 6, 0, ENT

The display will now show the current reset value. To change the value, continue the keypad sequence by entering the new value followed by ENT.

Example: To program a reset value of 200, press:
CIR#, 1, 6, 0, ENT, 2, 0, 0, ENT

Option R - Remote Serial Display - RS-422 Transmitter

This programmer option provides an RS-422 serial output to operate a remotely mounted serial display. The format of this serial data is compatible with Gemco displays only. Twenty-five feet of interconnecting cable is included with each display unless additional cable is specified. These displays are available with either 4 or 8 digit readouts and can be mounted up to 600 feet from the programmer. This option is not available when Options A and H are both ordered. Remote serial

VI.

ADVANCED FEATURES AND OPTIONS

PROGRAMMER OPTIONS CONT'D.

displays are ordered separately. See wiring diagram E-0205000-B on page 17 for installation details.

Option S - Brake Monitor

This option provides for on-line monitoring of brake stopping time and stopping angle. It allows the operator to program a maximum allowable stopping time and provides a relay output if this stopping time is exceeded. With simple keypad commands, the digital display will sample and hold the stopping time or angle for each machine cycle. If the programmed maximum stopping time is exceeded during any cycle of the machine, the brake monitor output relay will de-energize and its contacts can be used to stop the machine or sound an alarm. This relay will remain de-energized until the reset push button is pressed.

Terminal 5 of terminal strip S2 on the CPU module is the input terminal that starts the brake monitor timing cycle. An isolated contact wired between this terminal and ground terminal 4 starts the timing cycle whenever the contact opens. See wiring diagram E-0205100-B on page 17 for installation details.

The brake fault relay can be programmed to either energize or de-energize when the selected maximum stopping time is exceeded. For fail-safe operation, this relay should be programmed to be energized during normal operation and de-energized on a fault condition.

To program the operation of this relay, press:

CIR#, 1, 7, 7, ENT, (0 or 1), ENT

0 = Brake fault output is energized (ON) when the brake fault input is closed and a fault condition does not exist. Output will turn off when a fault condition exists or when the fault input is opened.

1 = Brake fault output is de-energized (OFF) when the brake fault input is closed and a fault condition does not exist. Output will turn ON when a fault condition exists or if the fault input is opened.

All units default to 0 when the system is initialized and will come from the factory set at 0.

To program the maximum acceptable stopping time, press:

CIR#, 173, ENT, Time Data, ENT

The Time Data can be programmed from 0.001 to 9.999 seconds. If the programmed stopping time is exceeded, the Brake Fault Output will de-energize until the Fault Reset Input is interrupted and re-applied by pressing the N.C. reset button.

To monitor press stopping time, press:

CIR#, 174, ENT

Stopping time will be displayed to 0.001 seconds resolution with a maximum stopping time of 9.999 seconds. The decimal point on the display indicates that the stopping time is being monitored. If the stopping time is exceeded during a particular cycle, four E's (EEEE) will be presented in the display along with the actual stopping time.

To monitor press stopping angle, press:

CIR#, 175, ENT

Stopping distance will be displayed in scale factor increments with a maximum distance of 999. The

displayed number represents the number of scale factor increments traveled from the time the brake is applied to when the mechanism comes to a complete stop. If the programmed maximum stopping time is exceeded while in this mode, four E's will be displayed along with the actual stopping angle.

When operating in either of the above modes, the display will maintain the stopping data until initiation of the next timing cycle. At this point, the display will indicate dashes until new data is available at the end of the timing cycle. Pressing the POS or RPM key will return the display from this mode to the normal operating mode.

To reset Brake Fault Output, Fault Reset Input must be de-activated (open circuit) and then re-actuated. Cycling the Fault Reset Input will cycle the brake fault relay to verify that the Brake Fault Output is cycling properly.

Note: If this PLS also incorporates Fault Check (Option C), the Fault Check Output will cycle OFF/ON when Brake Fault Output is reset.

Option T - Time Based Outputs

Option T allows the user to program up to 16 outputs to operate on a "Position On, Time Off" basis. Each output's time on dwell can be individually programmed from 00.01 to 99.99 seconds. A timed output may only have one set point and will operate when the programmed set point is reached due to rotation in either direction. If the timing is such that the set point is again reached while the output is still timing, the programmer will complete its original timing cycle and not start a new cycle. With this option, the overall systems update time is increased to 500 micro-seconds. Units are shipped with all outputs factory-set for standard position-based operation.

Each LS Circuit is programmed in the standard manner except the digits entered after pressing the "CIR OFF" key will represent the time on interval of the output relay.

To program an LS output circuit for time based operation, the circuit is accessed by using the appropriate 300 series code. A 0 or 1 is then entered to specify either normal limit switch operation or time based operation.

Access codes 301 = LS circuit 1
302 = LS circuit 2
303 = LS circuit 3
through 316 = LS circuit 16

Operation mode selection code

0 = Normal position based operation
1 = Time based operation

Example: To program LS output 8 for time-based operation, press:

CIR#, 3, 0, 8, ENT, 1, ENT

All outputs default to position based operation when the system is initialized and will be preset at the factory for normal position-based operation.

Option U - Selectable Speed Offsets

This option allows LS output circuits to be programmed

VI.

ADVANCED FEATURES AND OPTIONS

PROGRAMMER OPTIONS CONT'D.

to automatically turn on sooner as the speed of the machine increases. These same circuits will also offset back to their original positions as the speed decreases. The offset occurs in 4 steps at keypad selected RPM points. The selected LS outputs will also turn OFF below the programmed motion detect value. Typical applications include offsetting glue guns and pneumatic actuators to compensate for mechanical lag as machine speeds vary. The ability to turn these circuits off at the motion detect RPM value allows glue guns to be turned off if the machine comes to a stop with product halfway through a glue station. This speed offset function can also be used to actuate brake circuits sooner as machine speeds increase.

To select the number of LS outputs to be effected by the speed offset, press:

CIR#, 8, 0, ENT

The display will now show the number of circuits selected for speed offset operation. To change, continue the sequence by entering 1 through 8 to select up to 8 circuits or 16 to select all 16 output circuits. If 1 to 8 circuits are selected, they will always start at LS 1 and continue in sequence to the number selected. If one circuit is selected it will always be LS 1, if two, they will always be LS 1 and LS 2, etc.

Example: To select 4 circuits for speed offset operation, press:

CIR#, 8, 0, ENT, 4, ENT

LS output circuits 1 through 4 will now offset forward or back following changes in machine velocity.

When circuits are selected for speed offset operation, the programmed motion detect value described on page 24 will become the velocity at which these circuits all turn off. The motion detect circuit and speed offset circuit disable are tied together in all standard software packages. Consult the factory for software in which the motion detect and speed offset disable are independent. To program the minimum speed disable RPM value, follow the keypad sequence outlined under motion detect on page 24.

To program the four RPM points at which the offset occurs and the amount of offset that occurs at

these RPM points, access codes 81, 82, 83 and 84 are used. The "CIR ON" key is pressed, followed by the desired RPM transition point. Next, the "CIR OFF" key is pressed, followed by the desired amount of offset, in scale factor increments, that will occur at the selected RPM transition point.

Example: To program the first RPM transition point for 100 RPM and for 10 counts of offset to occur at this point, press:

CIR#, 8, 1, ENT

CIR ON (display shows current RPM value)

100, ENT

CIR OFF (display shows current offset amount)

1, 0, ENT

Note: Circuit 82, 83 and 84 are programmed in the same manner as above to incorporate the second, third and fourth RPM/offsets, respectively. Circuit 81 should always be programmed for the lowest RPM/offset settings. Circuits 82, 83 and 84 must be programmed in increasing RPM sequence.

Note: When the memory of the PLS is cleared through the use of Circuit 91 or by changing the scale factor of the unit, all limit settings will be cancelled, offset will be cancelled, all circuit outputs will go to standard operation, motion detect will go to 0, and Circuits 81 - 84 will be set to 65535 RPM and 0 offset.

To incorporate the features of this option, the system's scan time (output update rate) will increase from 200 to 400 micro-seconds. At this scan time, outputs will be updated in one degree increments at speeds up to 417 RPM for a scale factor of 360.

Gemco has done several versions of speed offset circuits including versions that linearly offset the circuits instead of the standard four-step version outlined above.

Consult the factory for details on special software features.

VII.

TROUBLESHOOTING

INTRODUCTION

The following procedures are intended to aid in isolating system malfunctions to field replaceable modules. These modules include the display/keypad module, CPU module, output/power supply module, auxiliary output boards, transducer and all interconnecting cables. Once isolated, the defective module should be replaced and returned for factory repair.

Field repair beyond this level is not recommended.

Note: The screw terminals of the CPU module terminal strip do not make electrical contact when not tightened down. Insure that these screw terminals are fully tightened when taking voltage readings.

PRELIMINARY CHECKS

Check all system wiring connections at the transducer, CPU module and output module. Amphenol-type connectors on the transducer and its cabling should be checked for tightness. A slight tug on all wire terminations will verify a good connection. Push-on cable connectors at the keypad, CPU and output modules should be checked for proper connections.

Verify that all wiring at the CPU module is in agreement with its legend plate. The terminal designations of your CPU module may not be identical to the enclosed general wiring diagrams due to the wide range of available options.

Note: Verify that the keypad cable is connected to a multipin connector located through a cutout in the lower left corner of the CPU module's sheetmetal base. Other similar looking connectors may have been used by mistake.

A. Input Operation

A1. Check the operating voltage of the 5 VDC and 15 VDC inputs at the CPU module. Voltage between the terminals labeled 5 VDC (terminals 1 and 2 of terminal strip S2) and ground (terminals 3 and 4 of terminal strip S2) should be 4.8 to 5.2 VDC. This voltage range is critical for proper operation of the microprocessor. Voltage between the terminal labeled 15 VDC (terminal 29 of terminal strip S2) and ground (terminal 30 of terminal strip S2) should be 14.3 to 15.3 VDC. This input powers the transducer excitation circuitry.

If either of these voltages are not present at the CPU module terminals, the input wires should be disconnected and the voltage level checked across the wires. If the correct voltage is seen across the input wires, a short condition probably exists within the CPU module and it should be replaced.

If the correct voltage levels are not seen across these wires, the power supply has failed. This power supply can be an integral part of a Gemco output/power supply module, a Gemco power supply without outputs or a standard power supply not provided by Gemco. All Gemco power supply modules have a circuit board-mounted line fuse that should be checked. AC input voltages to these modules should be 105 to 125 VAC or 210 to 250 VAC depending on the version specified.

After verifying the AC input voltages and line fuse, the 5 VDC and 15 VDC output should be verified at the power supply with all wiring disconnected at its output terminals. See diagram E-0190100-C, (pages 11-12), for the location of these output pins on a Gemco output/power supply module. On a Gemco power supply without outputs, these are screw

terminals that are clearly labeled on its circuit board.

If the 5 VDC and 15 VDC voltages are now correct at the power supply terminals, an open or short condition of the power supply to CPU module wiring should be suspected. Incorrect voltages at the power supply indicate a defective power supply and the complete power supply module should be replaced.

A2. Transducer excitation voltage should be checked at the CPU module terminal strip S1. Use the following procedures based on the type of transducer that your system was designed for:

A2a. Single-turn resolver: AC voltage across terminals 9 and 10 of terminal strip S1 (labeled Red and Bk/R) should be 7.0 to 7.9V RMS. This is the output voltage being supplied to the resolver rotor. If this voltage is not present, disconnect the resolver wires at the CPU module and recheck the voltage. If this voltage is still not present, the resolver excitation circuitry in the CPU module has failed and it should be replaced. If this voltage reappears, a short condition in the resolver or its cable should be looked for.

The return signals from the resolver stator windings wire to the CPU module on terminal strip S1 terminals 12 and 14 (labeled White and Bk/W) and terminals 13 and 15 (labeled Green and Bk/G). To verify the presence of these AC return signals, put a voltmeter across terminals 12 and 14 and rotate the resolver. A voltage reading that rises and falls between these terminals as the resolver is rotated indicates a good resolver return signal. Repeat this same procedure with your meter across terminals 13 and 15. No voltage or a voltage that does not vary as the resolver rotates indicates an open or short condition in the resolver windings or the resolver cable.

The blue resolver wire that connects to the CPU module at terminal strip S1 terminal 21 (labeled BL) is a feedback wire used to verify that the resolver excitation voltage has reached the resolver rotor. A loss of this feedback voltage is intended to indicate a disconnected or severed resolver cable or other resolver excitation fault. If this feedback voltage is not present, the display on the keypad will show all E's. A voltmeter across terminal strip S1 terminal 9 (labeled Red) and terminal 21 (labeled BL) should read 7.0 to 7.9V RMS. If this voltage is not present, but was present across terminals 9 and 10 when checked earlier, an open or short condition exists in the resolver or its cable. If it is present, and all E's still appear on the display, a fault in the CPU module has been detected and it should be replaced.

Note: The reason for an all "E" fault display can be quickly isolated without the use of a voltmeter. Remove the resolver cable wires from terminals 9, 10 and 21

PRELIMINARY CHECKS CONT'D.

(labeled Red, Bk/R and BL). Connect a jumper wire between terminals 10 and 21. The all "E" fault condition should disappear when this jumper wire is connected. If it doesn't, either the resolver excitation or feedback circuitry have failed and the CPU module should be replaced.

A2b. Multi-turn dual resolver: Dual resolver transducers consist of two resolvers connected together through a precision gear reducer (see diagram E-0210900-A, page 13). The first resolver is considered the fine resolver and keeps track of where the input shaft is in each revolution. The second resolver is considered the coarse resolver and keeps track of the number of revolutions seen at the input shaft. Both resolver rotor coils receive their excitation voltage from terminals 9 and 10 of the CPU module terminal strip S1. The blue resolver wire connected to its terminal is the feedback wire. The resolver excitation and feedback circuits should be tested in the same sequence as outlined under single-turn resolver.

The return signals from the two pair of stator coils appear across the following twisted pairs:

First resolver:

White (terminal 12) and Bk/W (terminal 14)

Green (terminal 13) and Bk/G (terminal 15)

Second resolver:

Yellow (terminal 17) and Bk/W (terminal 19)

Brown (terminal 18) and Bk/Br (terminal 16)

The presence of these return signals should be tested as outlined under single-turn resolver.

A2c. Absolute optical encoders (Binary transducers): CPU modules designed for use with binary transducers are compatible with transducers having an open collector or TTL level output. The binary input terminals of the CPU module are current sources that are considered "ON" when taken low (to ground). Each binary input terminal of terminal strip S1 will be labeled with its binary value (example: 2⁰, 2¹, 2², 2⁴, etc.). Terminal 24 or 25 is the common (ground) for use by the transducer. As the transducer input counts it takes the appropriate input terminals low.

To verify operation of the Gemco CPU module, disconnect the transducer and jumper from terminal 24 (ground /common) to each of the binary inputs. The count of the digital display should follow the changes in the binary input being simulated by the jumper wire.

Note: Remember that any programmed scale factor or offset will convert the display to read out in increments that are different than the binary input number being simulated by the jumper wire. To verify that the CPU module is reading the binary input correctly, the CPU module must be cleared of all scale factors and electronic offset. Once cleared, the digital display should show the same number that is being simulated at the input terminals.

If the CPU module counts correctly when inputs are simulated with the jumper wire, the Gemco system is functioning properly. If it does not count properly with the jumper wire, the CPU module should be replaced.

The manufacturer of the binary transducer should be contacted for assistance in troubleshooting its

operation.

A2d. Series 950CP linear displacement transducer: The transducer receives an RS-422 level 5 VDC trigger pulse from the CPU module. The return signal from the transducer is also an RS-422 level 5 VDC return pulse. The time interval between the trigger pulse and return pulse is converted to position information by the CPU module.

First verify that the remote 24 VDC power supply is providing a good 22 to 26 VDC input to the series 950CP linear transducer. To verify correct operation of the trigger pulse, connect an *isolated* oscilloscope across the terminals labeled "Trigger pulse, + Green, - Red". Set the oscilloscope to monitor a 5V level pulse that will be transmitted at a rate somewhere between once every 200 to 2000 microseconds, depending on the active stroke of the linear transducer (a shorter LDT has a faster transmission rate). A good transmit pulse will have an approximate 4 microsecond duration with 5V amplitude. If the transmit pulse is not seen, disconnect the linear transducer trigger pulse wires at the CPU module input terminals and recheck for this signal at the CPU module terminal strip. If the signal reappears with the linear transducer disconnected, look for a shorted cable or defective linear transducer.

The return pulse is monitored by connecting the oscilloscope across the CPU module input terminals labeled "Return pulse, + Brown, - Black." A good return signal will be a 5V level pulse having an approximate 1 microsecond duration. If no return signal is seen, disconnect the linear transducer return pulse wires at the CPU module and recheck for the signal across the two wires coming from the LDT. If there is no return pulse across the LDT wires, the linear transducer should be replaced. If the signal reappears when these wires have been disconnected, there is a defect in the CPU module input circuitry and the CPU module should be replaced.

A2e. Analog input devices: CPU modules designed for an analog input signal can be used with a wide range of transducers that provide an output matched to the CPU module input (0-10 VDC or 4-20ma). Typical installation problems involve voltage drop over long transducer lead runs or electrical noise being induced in this wiring so installation practices compatible with analog signals is required.

The first step in verifying proper operation of these input signals is to monitor the signal amplitude at the input terminals of the CPU module. These signals should swing through the full range of their rated output when monitored at the CPU module input terminals. A low analog input voltage at the CPU module can be the result of voltage drop in the transducer leads. This voltage loss can be compensated for by adjusting the scale factor to provide the correct readout at this lower maximum input voltage. A major loss of input voltage at the CPU module can be caused by a defective analog transducer or shorted condition in the input stage of the CPU module. To determine which device is causing the problem, disconnect the analog transducer at the CPU module and jumper a 9 VDC transistor battery across the ± 10 VDC input terminals. If the digital display shows a number that is 9/10 of the programmed scale

PRELIMINARY
CHECKS
CONT'D.

factor, the CPU module is fine and the analog transducer should be looked at. An incorrect display indicates a CPU module failure.

An unstable digital readout and/or limit switch output is generally due to fluctuations in the analog input signal. The series 1989 PLS provides 12 bit resolution from the analog input signal which means that a .002 VDC fluctuation in the input signal can result in a one count change in the digital readout and programmed setpoints. The PLS setpoint outputs have only one count hysteresis, which can result in setpoint oscillation. An oscilloscope across the CPU module input terminals will verify the presence of voltage fluctuations or spikes. A 9 VDC transistor battery, wired to the CPU module as mentioned above, will deliver a steady input signal and can be used to verify that the CPU module will operate properly when supplied an input from a known stable source.

A filter capacitor having a value of .047 to 1.0 microfarads can be wired across the CPU module analog input terminals. This can provide sufficient stabilization but will slow the response time of the analog signal. The higher the capacitor value, the slower the response time.

A2f. Type 950A analog inputs: This input option is intended for use with a Gemco Series 950A linear displacement transducer. It accepts the 0-10 VDC output of the Series 950A LDT into the same terminals as the standard analog input described previously. The quality of this 0-10 VDC input should be checked as outlined in the previous section. This unit differs from the standard analog input in that it provides the +15 VDC and -15 VDC power to the 950A LDT. This power is available at terminals 1 and 2 of terminal strip S1. The voltage across terminal 1 and ground (terminal 1 of terminal strip S2) should be -14 to -16 VDC. The voltage across terminal 2 and ground should be +14 to +16 VDC.

If a low voltage is seen, these wires should be disconnected at the CPU module and the voltage rechecked. If the voltage returns to correct levels, a defective 950A LDT or shorted wiring should be looked for. If the voltage remains low, the 15 VDC input at terminal 29 of terminal strip S2 should be checked. A good voltage at this input terminal indicates that the CPU module is defective and should be replaced.

A3. Optional inputs: There are several options that require a contact closure input to initiate a function. All contact closure input terminals are a current source that is taken to ground through the external isolated contact. This external contact can be a mechanical or solid state switch that can sink 15 VDC at 20ma to the ground of the Gemco CPU module.

These inputs are optically isolated but should not be wired directly to devices in a noisy electrical environment. Electrical noise induced on these input wires can trigger the input. To verify correct operation of these inputs, external wiring should be disconnected at the CPU module and a jumper wire installed between the input terminal and a ground terminal on the CPU module. If the correct response is seen with the jumper wire, the CPU module is fine and a problem in the external wiring or contact should be looked for.

The following is a list of the optional inputs with a description of their intended function.

A3a. Multi-program selection: These inputs allow the programming and selection of 8 different sets of output patterns. Three input terminals on terminal strip S1 labeled BCD1, BCD2 and BCD4 are taken to ground through a BCD selector switch or other device that will simulate the appropriate BCD input. The selected program will be displayed as the far left-hand digit of the digital display. The logic is High = 1 (contact open) which means that nothing wired to these input terminals will result in Program 7 being selected. Jumper wires connected from the 3 BCD input terminals to ground can be used to simulate the proper operation of the BCD switch. One jumper from BCD1 to ground should result in Program 6 being selected. Jumpers from BCD1 and BCD2 to ground selects Program 4, etc. Proper selection of programs with jumper wires indicates that your problem lies in the external BCD input device or its wiring. BCD selector switches mounted in high vibration areas have been known to lose contact continuity momentarily, resulting in sporadic limit switch outputs as the CPU module tries to shift from one program to another. Most software packages allow field selection of multiprogram selection via remote BCD switch or via the keypad. Switching to program selection via the keypad can help identify problems caused by the remote switch or its wiring. See programming instructions on page 27.

A3b. Reset to preset: This input resets the digital display and all outputs to a keypad selected number. The wires from this input should not be wired directly to any device in the noisy industrial environment. A relay mounted near the CPU module should be driven by the external reset sensor. The isolated contact of this relay should be wired across the input terminals of the CPU module. If a Gemco relay output module is used as part of your system, the relay module can be purchased with the reset option that provides a solid-state relay for this purpose. A 110 VAC signal from the remote reset sensor is wired to the reset input of the relay output module. The contact of this solid-state relay is wired to the reset terminal of the CPU module through the relay module cable assembly.

A jumper wire used to simulate a reset condition at the CPU module is the best way to verify proper operation of the CPU module itself.

A3c. Latch: Units having an auxiliary digital output like BCD, binary or gray code may incorporate the latch input option. Upon taking this input low, the auxiliary digital outputs will freeze and will not update until the input is released. This input is used to allow your PLC sufficient time to read this digital data. Upon release, the digital outputs will immediately update to current machine position. The digital display and limit switch outputs are not affected by this input. The display will continue to follow actual resolver position and all limit switch outputs will operate at the appropriate position.

A3d. Buss enable: This input enables the outputs from the auxiliary digital output terminals. Its intended use is to allow multiple digital outputs to be multiplexed into one PLC input card. The PLC selects the digital input that it wants to look at by taking the appropriate

PRELIMINARY CHECKS CONT'D.

buss enable input low. The buss enable input pin must be taken low to enable any digital outputs. If this option was specified but is not going to be used, a permanent jumper wire should be connected from this input terminal to a ground terminal on the CPU module.

A3e. Fault reset: Systems having the fault check or brake monitor option, or both, will use the same input terminal to activate the option and to reset a fault condition. A normally closed isolated contact wired from the fault reset terminal to ground activates the appropriate output. The fault check output is an oscillating signal at terminal strip S2 terminal 9. These oscillations stop when a fault condition is detected and remain off until the condition is corrected and the fault reset input is disconnected and reapplied. A Gemco relay module with the fault check option or a stand alone fault check relay must be wired to this oscillating output if a contact closure output is required. The special fault check relay will be energized under normal operating conditions and will deenergize when a fault is detected.

The brake monitor output is a low power solid state output from terminal strip S2 terminal 8 that will have the same electrical characteristics as specified for the limit switch outputs (sinking, sourcing, TTL). Some software turned this output ON on a brake fault condition, other software turned it OFF. Our newest software allows field selection of how this output will operate.

Once a brake fault is detected, the fault output will remain indicating a fault condition until the reset input is interrupted and reapplied.

A jumper wire from the fault reset input to ground will quickly let you determine whether reset problems are being caused by the CPU module or the external wiring and reset device.

Note: Removal of continuity (pressing of N.C. reset button) will cause the fault outputs to simulate a fault condition.

B. Output Operation

B1. CPU module outputs: All limit switch, motion detect, up, down and enable outputs will be current sinking, current sourcing or TTL depending on the output type specified by the systems catalog number. See page 21 for the electrical characteristics of these outputs.

When limit switch outputs are programmed, the output status LED's on the keypad will illuminate to indicate when the outputs are supposed to be on. These LED's only indicate that the microprocessor has signaled the output to operate but they do not verify that the output has responded.

The motion detect output turns on when a keypad selected RPM value has been exceeded. The Up and Down outputs turn on to indicate the direction that the display counted the last time resolver movement was sensed. The motion detect and Up/Down outputs do not have status LED's on the keypad.

The enable/disable keys on the keypad are used to turn the enable output on or off at terminal strip S2 terminal 6. The enable/disable keys do not effect the

operation of the limit switch outputs at the CPU module. If your system incorporates a Gemco relay output module, the enable output at terminal 6 will connect to this relay module and will turn the whole relay module on or off when the enable/disable keys are actuated.

To verify the operation of the output drivers test as follows:

B2. Current sinking (Option E) - When it turns on, this output takes the current applied to each output terminal to the CPU modules ground. The ground terminal of the CPU module must be tied to the ground of the current source so that the load sees a completed current flow path when the output is turned on.

Disconnect all wiring from the output terminals being tested to isolate the CPU module from electrical problems outside the module. Connect the positive (+) probe of a DC voltmeter to terminal strip S2 terminal 29 (labeled +15 VDC) and touch the negative (-) probe to each limit switch output in sequence. When the output being tested is ON, you will see 15 VDC at the voltmeter. When the output turns OFF, the 15 VDC signal will disappear. An output that is ON or OFF continuously indicates a defective output driver and the CPU module should be replaced.

B3. Current Sourcing (Option C): Systems having current sourcing outputs will have an input terminal (usually terminal strip S2, terminal 28) labeled +V source. The +V external, customer-supplied DC power supply is wired to this input terminal to provide the current that will be transmitted from the CPU module output driver when the output turns ON. This external power supply should be used only for computer level inputs. Solenoid valves or other noise producing loads sharing this power source can cause sporadic operation or cause damage to the CPU module circuitry.

Disconnect all wiring from the output terminals being tested to isolate the CPU module from electrical problems outside the module. The ground terminal of the CPU module must be connected to the ground of the current source. Connect the negative (-) probe of a DC voltmeter to a ground terminal on the CPU module (terminal strip S2, terminal 30) and touch the positive (+) probe to each limit switch output in sequence. When the output being tested in ON, you will see a voltmeter reading that equals the voltage being applied to the +V source input terminal from the external power supply. When the output is OFF, this voltage will disappear. Any output that is ON or OFF continuously indicates a defective output driver and the CPU module should be replaced.

B4. TTL (Option T): TTL outputs are wired similar to current sourcing outputs except that there is no +V source input from a remote power supply. In an off condition there will be an internally generated +4.7 to +5 VDC output at each CPU module output terminal in relation to its ground. When the output turns ON, the output driver goes to ground to sink the TTL level signal from the PLC input device into which the signals are being fed. The ground terminal of the CPU module must be connected to the ground terminal of the TTL input device.

To test operation, disconnect all wiring to the

PRELIMINARY CHECKS CONT'D.

output terminals of the CPU module to insure that electrical problems outside the unit do not interfere with its operation. Connect the negative (-) probe of a DC voltmeter to the CPU module ground terminal and touch the positive (+) probe to each output terminal in sequence. When the output is OFF, there will be a +4.7 to 5 VDC signal seen. When the output turns ON, this signal will disappear. Any output that is ON or OFF continuously indicates a defective output driver and the CPU module should be replaced.

C. Gemco relay output modules

Series 1989 relay output modules are used when high-power outputs are required by the loads being driven. The output module takes a 110 VAC or 220 VAC input and generates the +5 VDC and +15 VDC power required by the CPU module. It also generates a 22-24 VDC output for operation of the output relays. This voltage is present at each wire of the cable assembly that connects to a limit switch output on the Gemco CPU module. All relay output modules are intended for use with current sinking (Option E) outputs on the CPU module only. When the CPU module current sinking output turns ON, it sinks the 22-24 VDC output from the relay output module to ground which turns on the high power output relay. All relay output modules have a master enable/disable input that completely enables or disables all relay outputs regardless of the state of the CPU module limit switch output. To test operation of the relay output module, disconnect all wiring of limit switch outputs and the enable output at the CPU module. This insures that problems within the CPU module do not interfere with the testing. Using a jumper wire, connect the yellow wire (output enable) to a CPU module ground or ground wire in the cable assembly and leave this jumper wire in place. The enable LED on the relay output module should turn on to indicate that the output relays are enabled and ready for operation. Next, take a second jumper wire, connect it to a CPU module or cable assembly ground wire and touch it to each limit switch relay output wire in the cable assembly. As each wire is touched, the corresponding output relay on the output module will turn ON. An LED located next to each relay will illuminate to indicate that the relay has been told to turn on. If the LED illuminates, but the relay does not turn ON, the output relay itself has failed and should be replaced. If the LED does not turn ON, the output module circuitry has failed or there is an open in the cable assembly. To check for an open in the cable assembly, apply jumper wires in the same sequence outlined above except at the multipin connector on the relay output module. If the relay works when jumpered at the relay module connector, but not at the other end of the cable assembly, the cable assembly is defective. If the relay does not operate when jumpered at both locations, the output module circuitry has failed.

An output module relay that is on continuously can be caused by a short in the cable assembly. Disconnect the cable assembly at the relay output module multipin connector. If the relay turns off, the cable assembly wiring is shorted to ground. If the relay remains ON (status LED illuminated) there is a short in

the output module circuitry.

D. Output relays

D1. Mechanical relays: These relays are rated for loads up to 10 amps at 240 VAC or 10 amps at 30 VDC. A resistor/capacitor noise suppression circuit is located on the circuit board next to each relay socket. This circuit helps suppress electrical noise generated by inductive loads. If the relay is used to control an AC signal into a high impedance load, leakage in this RC noise suppression circuit may turn the load on even when the relay contact is open. Typical loads that may not operate properly due to this leakage include 110 VAC PLC input cards and very small control relays. To eliminate this problem, the capacitor can be removed from the RC network protecting the relay having the control problem. The capacitor is labeled C1 preceded with a prefix number that correlates it to a specific output relay.

Example: Capacitor 8C1 is part of the RC network protecting output relay number LS8. When using this relay for driving inductive loads like solenoids, a noise suppression device *must* be installed across the coil of the load. Use an MOV or RC noise suppressor for AC loads, or a commutating diode for DC loads.

Note: A solid state relay output module may contain both AC and DC solid state relays. AC relays will be black and DC relays will be red. Insure that the correct type of relay is being used for the load being driven.

D2. AC solid state relays: These triac output relays are rated for loads up to 3 amps at 280 VAC. Current leakage is 5ma at 280 VAC. This may be sufficient leakage to improperly turn on high impedance loads like PLC input cards or very small control relays. If leakage appears to be causing improper operation of your load, an 18Kohm 2 watt load resistor wired from the relay output to ground will generally eliminate the problem. Special low leakage relays are available. Consult the factory for details.

The standard triac relay is a zero crossing type relay which produces much less electrical noise than a random turn-on device. However, premature triac failure may result if it is used in a control circuit in which other control contacts are paralleled around the triac. If this paralleled contact opens and closes while the triac is turned off, transients may be generated that will damage the triac. Sporadic operation can also result if the triac is turned on while the paralleled contact is closed. A triac needs current flow to turn on which will not be available when the paralleled contact is closed.

It's recommended that an MOV or RC noise suppression device be installed across the coil of any inductive device, such as solenoids, that are being driven by our triac output relay.

D3. DC solid-state relays: These high-power open collector solid-state relays are rated for loads up to 3 amps at 60 VDC. The polarity of the load current *must* be wired through this relay per diagram E-0193301-D on page 16 of this manual.

When using this relay to drive an inductive load like a DC solenoid, a commutating diode *must* be

PRELIMINARY CHECKS CONT'D.

installed across the coil of the solenoid to eliminate high voltage spikes.

E. Electrical noise and power quality considerations:

This system is designed for use in an industrial environment and incorporates extensive transient suppression circuitry. However, the same general installation rules should be followed that apply to all microprocessor-based equipment.

Problems that can be attributed to extreme electrical noise or poor power quality include loss of, or changes in, program memory, loss of microprocessor initialization, keypad/microprocessor lock-up, sporadic outputs and damage to resolver drive circuits, auxiliary input circuits and output driver circuits.

E1. Grounding: Circuit board level noise suppression circuits, ground planes and cable shields all depend on a good earth ground for proper operation. Our field experience has shown that the quality of the service ground at many machines is marginal.

E2. Incoming power: The Gemco CPU module requires a 15 VDC and 5 VDC power source to operate. These power sources may be coming from a Gemco relay module if one is included in the system, from a Gemco power supply or from a power supply provided by others.

The amplitude of the 5 VDC supply is critical for proper operation of the microprocessor. A voltage below 4.8 VDC will prevent the logic circuits from operating and high voltage spikes can scramble data or damage the circuits.

The 15 VDC supply operates the resolver drive circuitry. High voltage spikes can damage the resolver drive circuits.

Solenoids, welders, large motors and variable-speed drives are all devices that generate excessive electrical noise throughout the power grid in a typical industrial environment. Isolation transformers or constant voltage type power supplies should be used to isolate microprocessor-based circuitry. The power on the output side of these isolation devices should be fed to the programmable limit switch and other microprocessor-based devices only. The loads being driven by the programmable limit switch output relays *must not* get their power from the output side of the isolation device. Using the output side of an isolation device to power loads other than the programmable limit switch totally defeats the purpose of the isolation device.

If an isolation device is used to provide AC power to a Gemco relay output module, *do not* jumper this same power from the AC input terminals of the relay module to its output relays. Power for the output relay loads should come from the input side of the isolation device or some other totally separate power source.

The output side of any DC power supply that is used to provide the 5 VDC and 15 VDC required by the Gemco CPU module must not be used to power

any other DC inductive load.

E3. Low level inputs: Low level inputs to the Gemco CPU module include the resolver cable and other special purpose contact inputs like reset to preset, latch and multiprogram selection.

The resolver should be wired to the CPU module using an uninterrupted run of cable consisting of twisted pairs with shields. Whenever possible, this cable should be run in a conduit by itself. If it must run in a conduit with other wiring, this other wiring should not include power wires above 110 VAC or wires driving noise producing loads.

If the resolver cable must be run through a terminal strip, it must be mounted in a small enclosure with no other wiring. The shields of the incoming and outgoing cable must be tied together and isolated from ground.

Special-purpose contact inputs all operate by connecting the input pin on the CPU module to a ground terminal on the CPU module through a remote contact or solid state switch. These computer level signals must be protected from induced electrical noise. The contact used to activate the input should not be located outside the enclosure in which the Gemco CPU module is mounted. Any wiring between the CPU module input terminals and this contact located within the enclosure should be routed away from any power handling relays, contactors or other noise generating devices.

If the input is to be activated by a remote device, the contact of the remote device should be used to energize a relay within the enclosure. The contacts of this relay are wired to the CPU module input terminals.

E4. Outputs: The low-power outputs from the Gemco CPU module are intended for use with a PLC input card, a Gemco relay output module or a solid-state relay board compatible with the low-power output. It's not recommended that these outputs be used to drive an inductive load like a small DC relay. If an output must be used for this purpose, care must be taken to insure that the relays inrush current does not exceed the outputs rating and a commutating diode *must* be installed across the relays coil to eliminate electrical spikes.

Any DC power supply used for sinking or sourcing outputs to a PLC input card should be used for this purpose only. This power supply should not be used to drive any inductive loads.

The high power relays on a Gemco relay output module or relay module supplied by others can generate excessive electrical noise if used to drive inductive loads. Noise-suppression devices must be installed across the coil of these loads as described on page 34. The power fed to these contacts must not come from the conditioned side of any isolation transformer or power conditioner used to power the programmable limit switch.

VII.

TROUBLESHOOTING GUIDE

SYMPTOM	POSSIBLE CAUSES
Display shows all E's.	Resolver disconnected, resolver cable problem or excitation circuitry failure. See input operation troubleshooting sections A1 and A2, page 30. If CPU excitation failure is found to be the cause of problem, review section E through E3, page 35 concerning electrical noise problems. Fault check units will display all E's when a fault condition is detected.
Display shows all P's.	Loss of microprocessor initialization. The initialization code number is programmed at the factory and should never be field-changed or lost. This code number establishes the locations in memory that the microprocessor looks for data and is specific to the software number and part number of the system. See the part number descriptor sheet supplied with the system for the correct initialization code and re-enter on the keypad. Loss of initialization code indicates a severe power fluctuation or electrical noise. Review section E through E3, page 35 if this condition reoccurs.
All relay output module outputs inoperative.	All output relays on a Gemco relay module are turned on or off by the enable/disable button on the keypad. When enabled, the enable LED on the relay module will be illuminated. Verify that enable button has been depressed and that enable LED on keypad and enable LED on relay module are illuminated. See section C, page 34 for troubleshooting details.
An individual high-power output relay on output module does not operate, but status light on keypad indicates proper operation.	Output relay failure. If relay status LED on output module operates but relay doesn't turn on, relay may have failed. Replace relay and/or check output fuses on solid state relay. A PLC input card or small relay being fed by our output relay may remain on when our relay is off due to leakage in the relays noise suppression circuit. See section D through D3, page 34 for details and notes on relay wiring diagrams on page 16. Review section C, page 34 for details on isolating the problem to the CPU module, cable assembly or relay output module.
An individual low-power output from the CPU module does not operate but status LED on the keypad indicates proper operation.	Output driver failure. Review section B through B4, page 33 for troubleshooting details. If this is a reoccurring problem, review section E4, page 35 for possible installation problems.
System operates properly but exhibits a random momentary loss of all outputs.	Random momentary loss of all power to the system. A loss of power for as short a duration as 50 milliseconds will cause the system to shut down. When power is reapplied, the system can take several seconds to reinitialize itself. During this time period, all outputs are disabled. This intermittent loss of power could be caused by a bad terminal strip connection, bad relay contact, application of a very large motor load or momentary loss of incoming plant power. Momentary loss of continuity in the multi-program selector switch on multi-program systems. The selection of program is accomplished by a BCD switch or relay logic wired from these inputs to ground. Any momentary loss of these inputs will be read as a program change resulting in all outputs being inhibited as the new output patterns are compiled in memory. High vibration where the selector switch is mounted or bad contacts on the switch or logic relays should be looked for. Review section A3 and A3a, page 32 for details.
Mechanical output relays operate sporadically.	Low AC power supplied to relay output module. The mechanical output relays can become more sensitive to low input power as additional relays energize. When using mechanical relay output modules, the incoming AC voltage should be 110 VAC minimum. Review sections C, D and E on pages 34-35 for other causes.
Keypad displays meaningless data. Outputs may or may not operate properly.	System mounted in a high-shock or vibration area causing intermittent electrical connections. System operating in a high-electrical noise environment. Review installation instruction concerning routing of cables on page 9. Review general electrical noise considerations under troubleshooting section E on page 35. Keypad ribbon cable connected to wrong mating connector on CPU module. Correct connector is 14 pin connector accessed through cutout in lower left corner of sheetmetal base. See general wiring diagram E-0190100-C on pages 11-12 for location.

VII.

TROUBLESHOOTING GUIDE

SYMPTOM	POSSIBLE CAUSES
The display and outputs lose synchronization with machine position.	<p>If the reset to preset option is being used, electrical noise on the wiring to this input can cause unwanted resets. Also, all resets triggered by the use of this input will be lost on a power failure. Preview page 27 and troubleshooting section A3b, page 32 concerning the proper use and installation of this option.</p> <p>A gradual reoccurring loss of synchronization is generally caused by slippage in the mechanical couplings to the resolver. Verify the mechanical integrity of couplings, sprockets, chains, etc. that are in the drive train to the resolver's input shaft. The resolver assembly uses a small, internal flexible coupling to connect its input shaft to the resolver, mounted inside the assembly. Disassemble the resolver and verify the tightness of the coupling screws.</p>
Nonsequential count on digital display.	<p>A programmed scale factor that is larger than the system's resolution will result in counts being skipped. The location of the skipped counts will be spread evenly over the full scale factor. Verify the programmed scale factor by depressing the scale factor button on the back of the keypad and compare it to the system's resolution as specified by its part number.</p> <p>An open or shorted condition in the resolver secondary coil or cable will result in the display jumping the equivalent of 25% of the scale factor. See troubleshooting section A2a on page 30.</p> <p>Multi-turn dual resolver systems use two resolvers mounted within the resolver assembly that are coupled together through a precision gear reducer. The synchronization of the two resolvers is critical for proper operation of the PLS. A loss of synchronization will result in the digital display count jumping forward or backwards by the value of the programmed scale factor. The resolvers cannot be resynchronized in the field. See section A2b on page 31.</p>
System will not accept programming instructions.	<p>Verify that keyswitch is in program position. Verify that the programming sequence is being followed exactly. Omission of the "ENT" key in all required locations is a common mistake.</p> <p>Flashing decimal points indicate multiple setpoints on the selected circuit. To see all settings, continue to depress the "CIR ON" or "CIR OFF" key until all setpoints have been displayed.</p> <p>Verify that both ends of the keypad to CPU module cable assembly are fully inserted.</p> <p>If the membrane keypad fails, it is usually due to a shorted condition under one of the keys. If the digital display locks on some random number during programming and cannot be cleared by powering the system down, suspect a keypad failure.</p>
Setpoints not firing at programmed position.	<p>Probably due to programming errors. Flashing decimal points on the display indicate that multiple setpoints are programmed on the selected circuit. After calling up a circuit, continue depressing the "CIR ON" or "CIR OFF" key to view all setpoints held in memory. Many programmers think they have changed a setpoint location but have really added another setpoint on the same circuit.</p> <p>Any circuit that has a programmed OFF setting without corresponding ON or an ON without corresponding OFF will change state when the position passes through zero. Review programming instructions in section IV, page 24.</p> <p>Leakage in the noise-suppression circuits of the high power solid state relays and mechanical relay noise suppression circuits may cause sporadic operation of high impedance loads. See troubleshooting sections D1 and D2, page 34 for details.</p>

Replacement Part Information *

Key	Order #	Description	Key	Order #	Description
1	SDO323100	Keylock Assembly	18	C0773300	Enclosure for: Mechanical & Solid-State AC & DC
2	SDO375600	Faceplate Assembly w/ Lock	18A	C0773500	Enclosure for Power Supply Module
3	SDO322101	LCD Board Assembly	18B	C0682100	Enclosure for PC Interface Module
4	SDO322202	LED Board Assembly	19	SDO337203	Open Collector Board
5	04530056	Standoff	19A	SDO337201	Triac Board
6	C0760200	Rear Cover	19B	SDO334000	Mechanical Relay Board
7	C0755100	CPU Cover w/ Data Plate	20	04526004	Individual Output Fuse (Solid-State Units Only)
8	04530077	Standoff	21	04523001	Relay Solid-State A/C
9	SDO373510	* Option Board (RS-232)	21A	04523003	Relay Solid-State D/C
9A	SDO373520	* Option Board (RS-422)	21B	04523022	Mechanical Relay SPDT
9B	SDO373530	* Option Board (RS-232 & RS-422)	22	SDO337400	PC Interface Board
9C	SDO373540	* Option Board (Analog)	23	04513022	TIL119 Driver Chip
10	SDO331100	* R/D Board (Single)	24	SDO333000	Power Supply Board
10A	SDO331112	* R/D Board (Dual)	25	04526005	Line Fuse 1/2 AGC
10B	SDO324600	* Binary Input Board			
10C	SDO356800	* Dual Axis Input Board			
10D	SDO324630	* D-10 Analog Input Board			
11	04521067	Edge Card			
12	SDO348900	* Expansion Board			
13	SDO322300	* CPU Board			
14	C0693100	CPU Base			
15	Output Board	See #19, 22, 24			
16	SDO335300	Transformer 110V			
16A	SDO362800	Transformer 220V			
17	04530191	Standoff			

Miscellaneous Parts		
	SDO322900	CPU to Display Cable
	SDO337900	CPU to Remote Display
	04521098	Key In Plugs for Edge Card
	SDO371100	DB25 Connector (RS-232)
Single	SDO296000	Resolver Connector Kit
Dual	SDO352400	Resolver Connector Kit

* Must Specify Complete Catalog No. of 1989 PLS.

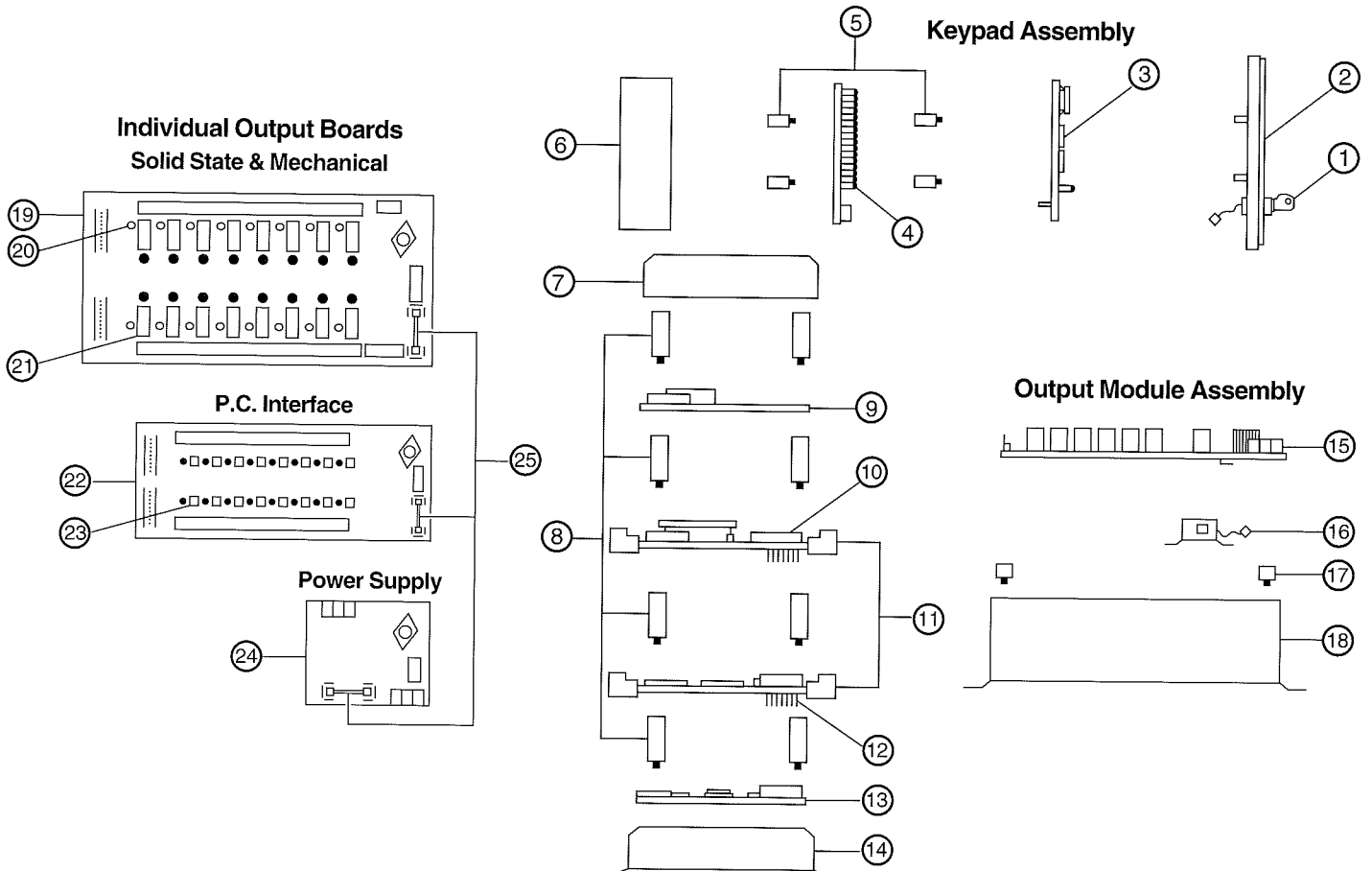

Wiring Diagrams

Description	Diagram Number
Dual axis PLS with Series 950CP linear transducer input	E-0203800-B
Single axis PLS with Series 950CP linear transducer input	E-0203700-B
Wiring diagram for 1989 CA-16-R-12-64-E-A3-R-0 system	E-0208100-C
General wiring diagram for dual axis PLS with resolver inputs	E-0208400-C
General wiring diagram for typical single axis PLS with resolver input and remote relay output module	E-0208500-C
General wiring diagram for typical single axis PLS with analog linear transducer input and remote relay output module	E-0209900-C
General wiring diagram for dual axis PLS with resolver inputs and remote output module	E-0212600-C
Single axis PLS with resolver input, 32 outputs wired to TTL PLC input card	E-0200900-D
Wiring diagram for 1989 A-16-R-12-S-E-A3-B-12-M-X system	E-0205700-D
Wiring diagram for 32 circuit PLS with Series 950CP linear transducer input	E-0210100-D

NOTES

GEMCO

AMETEK[®]
PATRIOT SENSORS

1080 NORTH CROOKS ROAD • CLAWSON, MI 48017 USA
800-635-0289 • 248-435-0700 • Fax 248-435-8120
www.patriotsensors.com • www.ametek.com

741A
1989.MIF1
10/00 • Z46
IM