

Series 953



## INSTALLATION MANUAL

LINEAR DISPLACEMENT TRANSDUCERS

# 953D VMAX™

Linear Displacement Transducer



**ABSOLUTE PROCESS CONTROL  
KNOW WHERE YOU ARE... REGARDLESS**

# Contents

**Chapter 1: 953D Overview** .....2

**Chapter 2: Installing** .....4

2.1 Installing to a Mounting Bracket .....4

2.2 Installing in a Hydraulic Cylinder .....5

**Chapter 3: Wiring** .....8

3.1 CP (Control Pulse).....8

3.2 VP (Variable Pulse) .....8

3.3 RS (Start/Stop) .....9

3.4 Wiring Connections .....9

3.5 Features .....10

3.6 Troubleshooting .....13

3.7 Part Numbering System .....14

**Appendix C: Specifications** .....15

**NOTE:** Ametek has checked the accuracy of this manual at the time it was approved for printing. This manual may not provide all possible ways of installing and maintaining the LDT. Any errors or additional possibilities to the installation and maintenance of the LDT will be added in subsequent editions. Comments for the improvement of this manual are welcome.

Ametek reserves the right to revise and redistribute the entire contents or selected pages of this manual. All rights to the contents of this manual are reserved by Ametek. VMAX is a registered trademark of Gemco.

## Unpacking

Carefully remove the contents of the shipping carton and check each item on the packing slip before destroying the packing materials. Any damage must be reported to the shipping company. If you do not receive all of the parts, contact Ametek at 800-635-0289 (US and Canada) or 248-435-0700 (International).

Most probes are shipped in a Tube. To remove the metal end cap, use a large, flat blade screw driver or a metal rod and tap on the inner edge of the cap until it pivots. Grab the cap and pull it out. Use caution as the edge of the metal cap may be sharp.

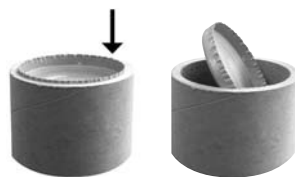

If you have an RMA warranty claim, pack the probe in a shipping tube or with stiff reinforcement to prevent the probe from being bent in transit.

# Chapter 1: 953D Overview

The 953D VMAX is a magnetostrictive Linear Displacement Transducer (LDT) for highly accurate continuous machine positioning in a variety of industrial applications.

This sensor is built to withstand the most severe environmental conditions and is completely absolute. This means that power loss will not cause the unit to lose position information or require re-zeroing. The non-contact design allows this device to be used in highly repetitive applications without mechanical wear.

## Features

The 953D has a truly unique feature. This LDT has auto-tuning capability, the ability to sense a magnet other than the standard slide magnet and adjust its signal strength accordingly.

There is an indicator LED that is located at the connector end of the probe and provides visual status information regarding the operation of the probe. Green indicates proper or normal operation. Red indicates the loss of the magnetic signal or a probe failure. The LED turns Yellow if no interrogation signal is detected. When the probe is in the normal mode of operation, the LED will remain illuminated continuously.

LED Colors	
<b>Green</b>	Magnet is present and within the active range.
<b>Red</b>	Fault, the LDT has lost its signal from the magnet or the magnet has moved into the Null Zone or Dead Band.
<b>Yellow</b>	No external interrogation pulse detected.

**NOTE:** The series number on your LDT is a record of all the specific characteristics that make up your unit. This includes what interface type it is, its output signal and range, the type of connector the unit uses, and stroke length. For a translation of the model number, see Section 3.7 Part Numbering System.

The 953D VMAX with Digital Output is a Linear Displacement Transducer. It provides a Control Pulse, Start/Stop or Variable Pulse output signal that is proportional to the position of the magnet assembly along the length of the probe.

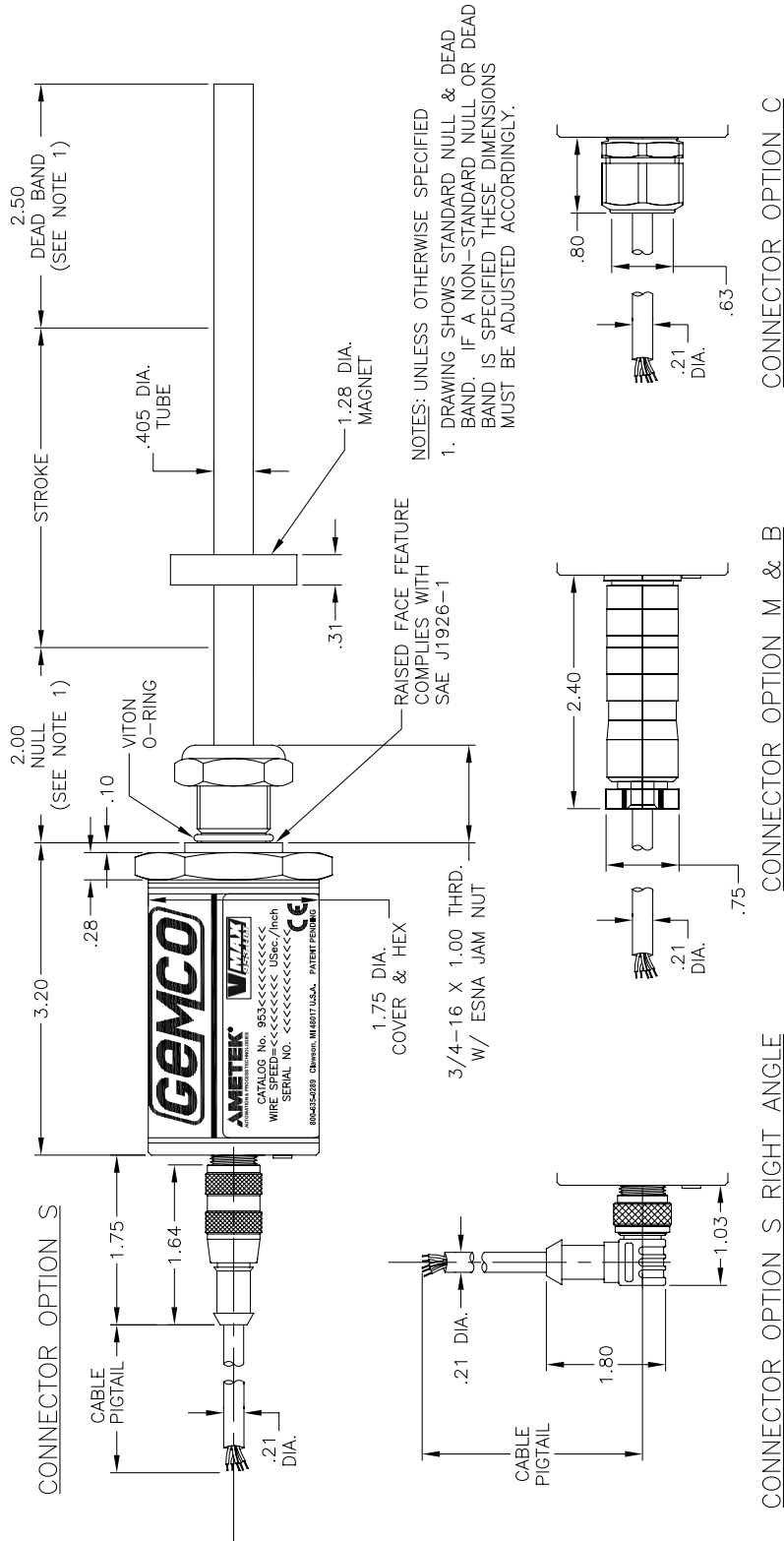

Figure 1-1 953D Dimension Drawing



## Chapter 2: Installing the LDT

If a mounting bracket or other part is used that is made of ferromagnetic material (a material readily magnetized), it should be placed no closer than 0.25" from the LDT's rod end to minimize the effects of magnetic flux distortion. This can cause an inaccurate measurement of the magnet position.

Non-ferrous materials, such as brass, copper, aluminum, non-magnetic stainless steel, or plastics, can be in direct contact with the magnet assembly and rod end without producing any adverse results.

### 2.1: Installing the LDT to a Mounting Bracket

Parts discussed in this section can be found in Figures 1-1 and 2-1.

1. Unscrew the LDT's jam nut from the threads protruding from the hex mounting base.
2. Insert the LDT's rod end into the mounting bracket's hole. The mounting bracket may contain a 3/4-16 UNF-2B threaded hole. In this case, screw the LDT into this hole using the threads protruding from the hex mounting base.
3. Once the LDT is in place, screw the jam nut back onto the threads of the hex mounting base. Use the 1.75" hex mounting base on the head assembly to tighten the LDT to the bracket.



**WARNING:** Do not use the blue aluminum cover of the head assembly to tighten the LDT within the bracket (see Figure 2-1). This may damage the LDT and will void your warranty. To tighten the LDT within the bracket, use the 1.75" hex mounting base on the head assembly.

If the length of the LDT's rod end is less than 30", skip to the sub-section: Mounting the Magnet Assembly.

#### Installing Support Brackets

It is recommended that a support bracket be used

with LDTs having a rod 30"-71" in length. Supporting the end of the rod will minimize operational errors and protect against damage due to shock and vibration. If the length of the LDT's rod is 72" or longer, it is recommended that additional support brackets be used. These additional support brackets must be made of a non-ferrous material. Because these additional support brackets will interfere with the magnet's movement, a special split-type magnet assembly must be used. To order a split magnet (P/N SD0411200) and support brackets (P/N SD0411100), contact the factory at 800.635.0289.

To install a support bracket for an LDT having a rod 30"-71" in length, perform step 4a. If the rod is longer than 71", perform step 4b.

- 4a. If the support bracket is made of a ferromagnetic material (material readily magnetized), install the support bracket no closer than 0.25" from where the LDT's dead band ends and the area of stroke begins. Continue to the sub-section: Mounting the Magnet Assembly.

To install two or more support brackets for a LDT having a rod 72" or longer in length, perform the following steps:

- 4b. Install support brackets at increments of 48" throughout the LDT's rod. Support brackets placed within the Null Zone and area of stroke or closer than 0.25" to the beginning of these areas must be made of a non-ferrous material.

#### Mounting the Magnet Assembly

Before mounting the magnet assembly, the following should be considered:

- Ferromagnetic material should not be placed closer than 0.25" from the LDT's magnet assembly or rod end. Failure to do so could cause erratic operations.
- Minimal clearance between the LDT's rod and the magnet assembly through the full stroke is

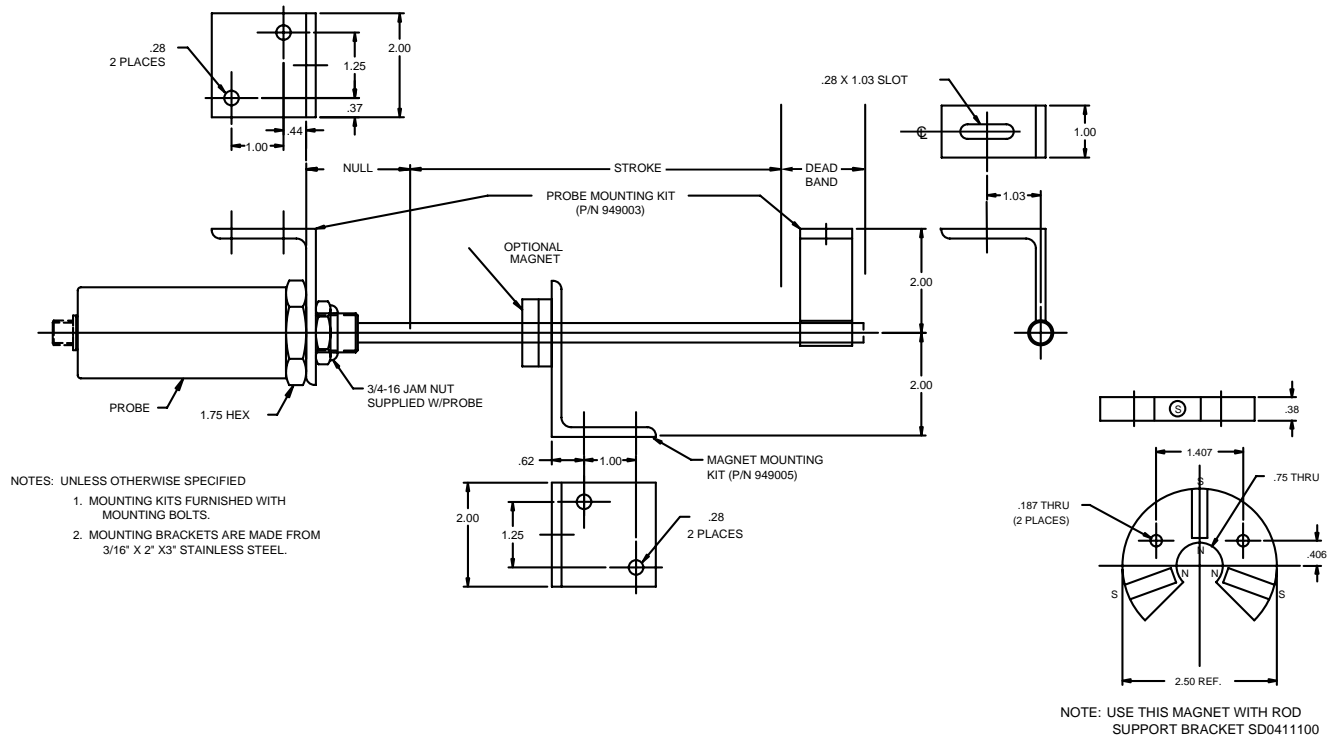

Figure 2-1: Mounting the LDT

required. Stress between the magnet and the rod can cause flexing of the mounting brackets. This may result in non-linearity.

- LDTs using a split magnet assembly must keep the diameter of the magnet assembly around the rod throughout the complete stroke. The diameter of this magnet assembly should not be more than 0.2" away from the rod. Split magnet assemblies outside of this range will cause signal loss.

To install the magnet assembly, perform the following steps:

1. Slide the magnet assembly over the LDT rod.
2. Mount the magnet to the non-ferrous, movable portion of the device being controlled using non-ferrous screws.

## 2.2: Installing the LDT in a Hydraulic Cylinder

Before installing an LDT in a hydraulic cylinder, note the following considerations. Items discussed in this section are found in Figures 1-1 and 2-1.

- A non-ferrous spacer must be used to separate the magnet assembly from the head of the piston rod. See Figure 2-2.
- The magnet should not be closer than 2.0" from the base of the LDT's hex head when the piston rod is fully retracted. In instances where space restraints exist, it may be required to countersink the magnet into the piston rod. Two magnets are available for mounting to the piston: the standard 1.29" in diameter (P/N SD0400800) four-hole magnet and the 1.0" magnet (P/N SD0410300) designed exclusively for countersunk mounting applications. The 1.0" magnet must be secured with a snap ring.



- An O-ring is provided at the base of the LDT's mounting hex for pressure sealing. The O-ring seal was designed to meet Mil-Std-MS33656. Refer to SAE J514 or SAE J1926/1 for machining of mating surfaces.
- A chamfered rod bushing in front of the magnet may be required. It is recommended that a chamfered rod bushing be used with LDTs having a rod 60.0" or longer. This bushing will prevent wear on the magnet assembly (wear occurs as the piston retracts from extended lengths). This rod bushing should be manufactured from a high wear polymer, such as Teflon®.
- It is recommended the bore for the cylinder piston rod have an inside diameter of at least 0.50". The LDT rod has an outside diameter of 0.405". Use standard practices for machining and mounting these components. Consult the cylinder manufacturer for details on applicable SAE or military specifications.

It may be necessary to perform machining and mounting operations on the hydraulic cylinder before installing the LDT. Consult the information and specifications provided by the cylinder manufacturer before beginning the following steps:

1. Unscrew the LDT's jam nut from the threads protruding from the hex mounting base.
2. Position the non-ferrous spacer against the piston face, followed by the magnet, and then the chamfered rod bushing if the LDT's rod is 60.0" or longer in length.
3. Insert non-ferrous screws through the chamfered rod bushing (if used), magnet, and non-ferrous spacer. Secure items by tightening screws.

If the leading edge of the magnet will come closer than 2.0" from the base of the LDT's hex head when the piston rod is fully retracted, it will be necessary to counterbore the magnet assembly into the piston rod. Both the standard 1.29" four-hole magnet assembly (P/N SD0400800) and the 1.0" magnet assembly (P/N SD0410300) are designed for counterbored mounting applications. If it has a 1.0" magnet assembly, a snap ring will be needed to hold it in place.

4. Insert the LDT's rod into the hole of the hydraulic cylinder's mounting bracket.

The protective Plug may need to be removed from the hydraulic cylinder before inserting the LDT. The end cap should contain a 3/4-16 UNF-2B threaded hole. Screw the LDT into this hole using the threads protruding from the LDT's hex mounting base.



**WARNING:** Do not use the blue aluminum cover of the head assembly to tighten the LDT within the bracket (see Figure 2-1). This may damage the LDT and will void your warranty. To tighten the LDT within the bracket, use the 1.75" hex mounting base on the head assembly.

With the LDT properly installed inside the hydraulic cylinder, it may be necessary to assemble parts of the hydraulic cylinder. For assistance in this task, refer to the information provided by the cylinder manufacturer.

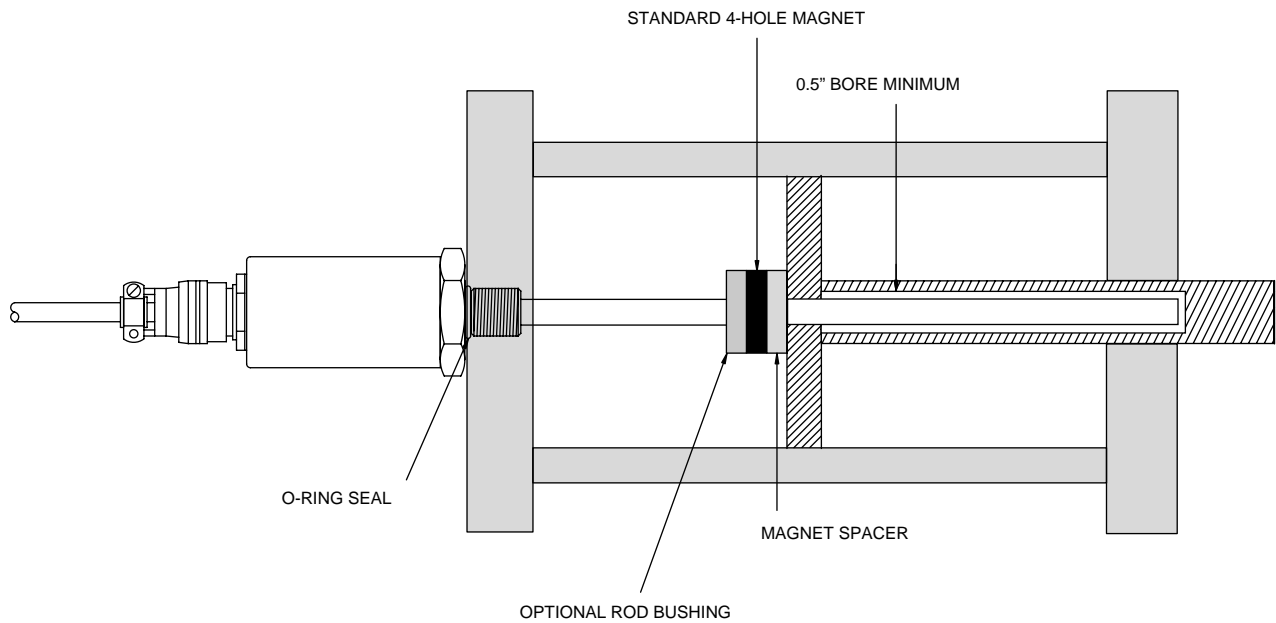
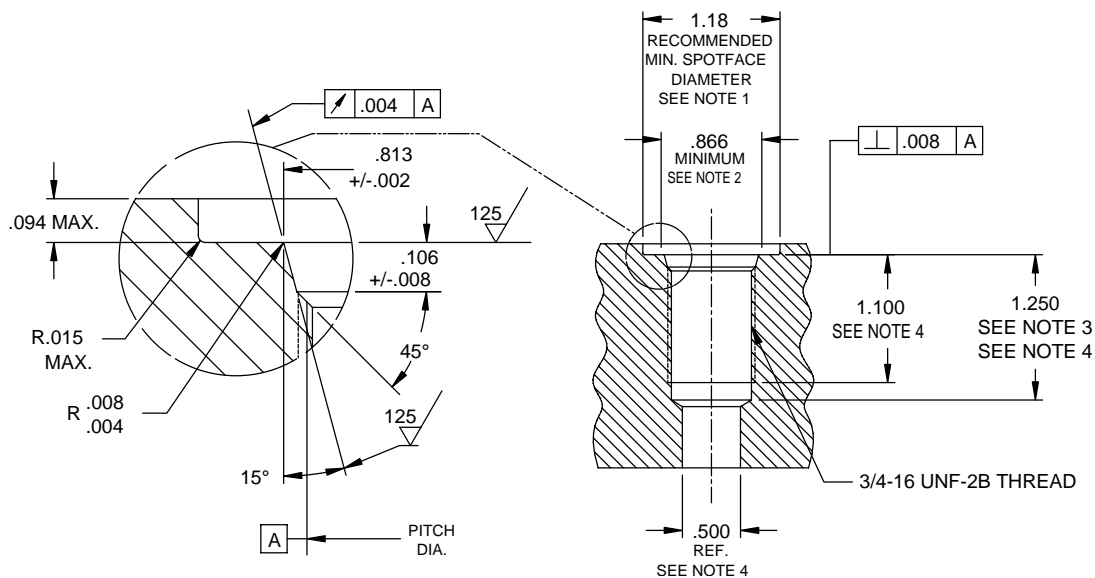

Figure 2-2: Mounting LDT in a Hydraulic Cylinder



NOTES:

1. IF FACE OF PORT IS ON A MACHINED SURFACE, DIMENSIONS 1.180 AND .094 NEED NOT APPLY AS LONG AS R.008/.0004 IS MAINTAINED TO AVOID DAMAGE TO THE O-RING DURING ASSEMBLY.
2. MEASURE PERPENDICULARITY TO A AT THIS DIAMETER.
3. THIS DIMENSION APPLIES WHEN TAP DRILL CANNOT PASS THROUGH ENTIRE BOSS.
4. THIS DIMENSION DOES NOT CONFORM TO SAE J1926-1.

Figure 2-3: Port Detail (SAE J1926/1)

## Chapter 3: Wiring

### 3.1 CP (Control Pulse)

The Control Pulse signal interface of the VMAX digital output series is a differential RS-422 output. The maximum cable length for the differential digital LDT's is 1,500 feet. To initiate a start pulse, an external device is used. This start pulse should be a minimum of 1.0 microsecond in duration. After the start pulse is received, the LDT will generate a stop pulse of 2 microseconds in duration. The time between the leading edge of the start pulse to the leading edge of the stop pulse is proportional to the distance from the Null Zone to the Magnet. The order of these two pulses is illustrated in the Figure 3-1. To wire the 953D-CP, see Figure 3-6. For proper grounding information, see Section 3.4.

Figure 3-1 953D-CP

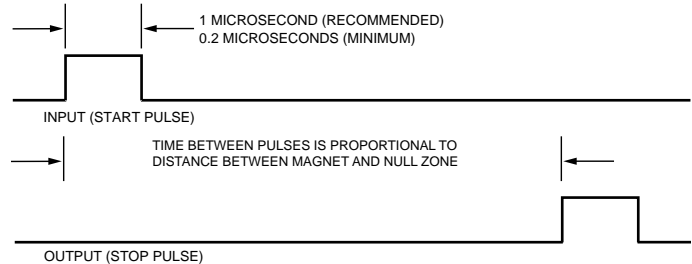

### 3.2 VP (Variable Pulse)

The Variable Pulse signal interface of the VMAX digital output series is a pulse width modulated signal (RS-422). The maximum cable length for the differential LDT's is 1,500 feet. This LDT can also be configured for external or internal interrogation. External interrogation is when an external device connected to the LDT generates a start pulse. This start pulse should be a minimum of 1.0 microsecond in duration. Within 50 nanoseconds after the leading edge of the start pulse has been received, the LDT will generate an output pulse. The duration of the output pulse is proportional to the distance from the Null Zone to the Magnet. The order of these two pulses is illustrated in Figure 3-2. The 953D-VP can also generate internal interrogations. This LDT will continually output pulse width modulated signals. As with a 953D-VP using an external interrogation, the duration of this output pulse is proportional to the distance from the Null Zone to the Magnet. This is illustrated in Figure 3-3. To wire the 953D-VP, see Figure 3-6. For proper grounding information, see Section 3.4.

Figure 3-2 953D-VP with External Interrogation

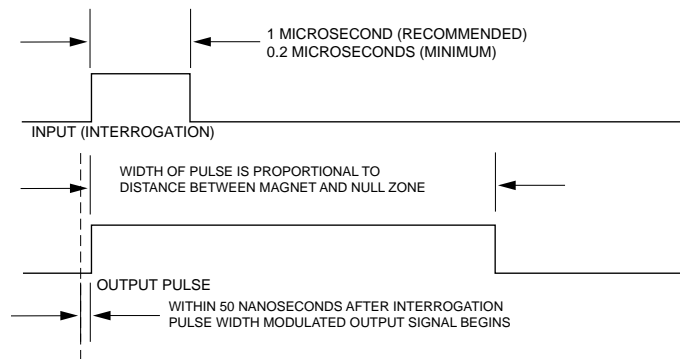
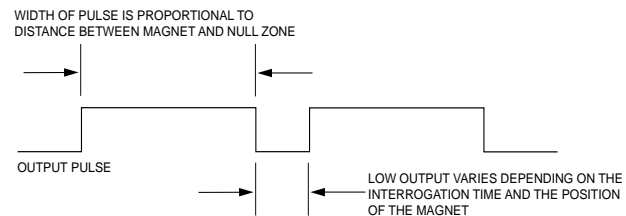

Figure 3-3 953D-VP with Internal Interrogation



### Recirculations

The method used to improve the resolution of a system using a digital LDT. The "on" Time of a pulse width output is multiplied by a specific factor (from 1-255). This multiplication provides more counting time for the counter in the customer's electronics, thus improving the resolution. The only disadvantage to the higher recirculation numbers is the time needed to process the signal.



### 3.3 RS (Start/Stop)

The Start/Stop signal interface of the VMAX digital output series is differential RS-422 output. The maximum cable length for differential LDT's is 1,500 feet. To initiate a start pulse, an external device is used. This start pulse should be a minimum of 1.0 microsecond in duration. Within 50 nanoseconds after the leading edge of the start pulse, the LDT will generate a start pulse of 2 microseconds in duration. A stop pulse of 2 microseconds in duration will follow. The time it takes from the leading edge of the start pulse to the leading edge of the stop pulse is proportional to the distance from the Null Zone to the Magnet. The order of these two pulses is illustrated in Figure 3-4. To wire the 953D-RS, see Figure 3-6. For proper grounding information, see Section 3.4.

Figure 3-4 953D-RS

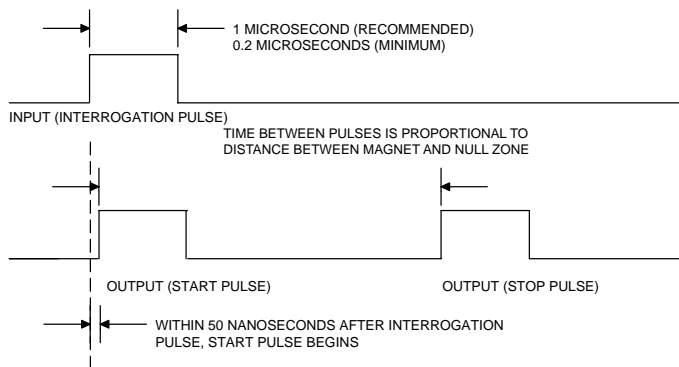

### 3.4 953D Wiring Connections

Once the LDT has been installed, wiring connections can be made. There are two groups of connections you will need to make. They are as follows:

- Power Supply Connections (including ground and shield)
- LDT Input/Output Connections

#### Power Supply/Ground Connections

The 953D standard cable is a 6 Pin, 12mm, Euro Style cordset. It has 6 conductors of 24ga, with an aluminum/polyester/aluminum foil with drain wire plus an overall braid of tinned copper shield. Cable O.D.

is .270. To reduce electrical noise, the shield must be properly used. Connect the cable's shield to the controller system GND.

Always observe proper grounding techniques such as single point grounding and isolating high voltage (i.e. 120/240 VAC) from low voltage (7-30 VDC cables). Whenever possible, this cable should be run in conduit by itself. The power supply common, the cable shield and a good earth ground should be connected together at the location of the power supply common.



#### WARNING

Do not route the VMAX output cable near high voltage sources.

In order for the 953D to operate properly, the LDT's external power supply must provide a voltage between +7 to +30 VDC. The power supply must be rated at 150mA minimum if not using recirculation. The power supply should provide less than 1% ripple and 10% regulations. (The power supply should be dedicated to the LDT to prevent noise from external loads from affecting the position readings.)

Figure 3.5 Power Supply Wiring

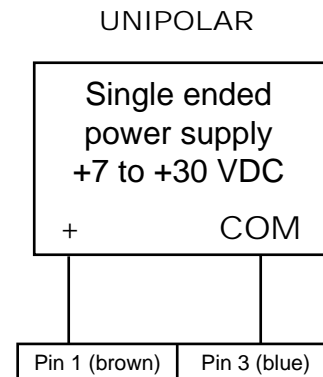
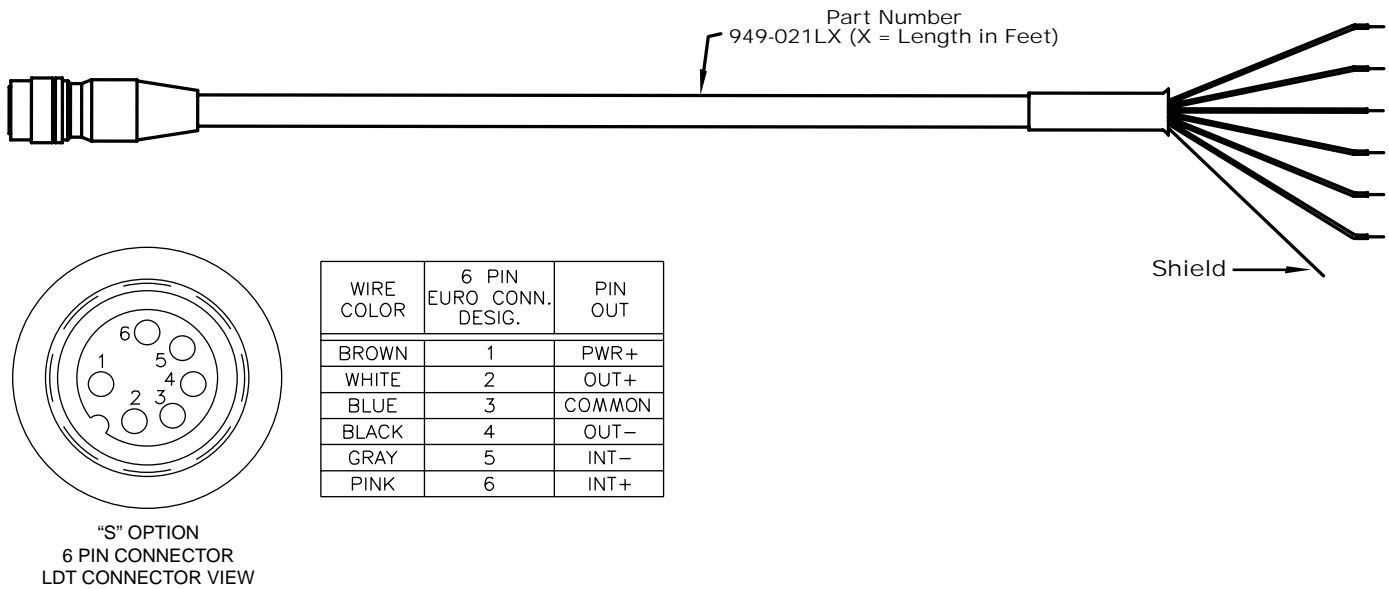



Figure 3.6 Wiring Diagram



### 3.5 Features

#### Automatic Gain Control

The Automatic Gain Control feature will automatically search and find the magnet on power up, if power is applied without a magnet on the LDT, the LED will turn RED indicating no magnet signal is detected. Turn power off and place magnet within the active stroke area. Re-apply power.

LED Colors	
<b>Green</b>	Magnet is present and within the active programmed range.
<b>Red</b>	Fault, the LDT has lost its signal from the magnet or the magnet has moved into the Null Zone or Dead Band.
<b>Yellow</b>	No external interrogation signal detected.

Accessories	
P/N	Description
949021L6	6 Foot, 6 Pin, Straight, 12mm Euro Cable
949022L6	6 Foot, 6 Pin, Right Angle, 12mm Euro Cable
SD0400800	Standard 4 Hole Magnet
Consult factory for complete accessory offerings.	

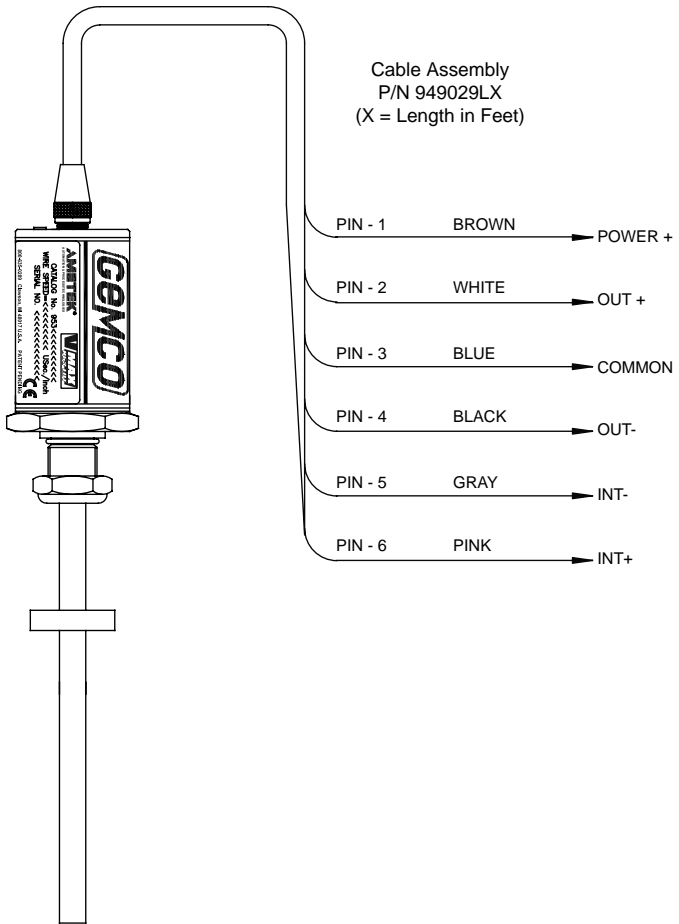

Figure 3-7: Wiring for Connector Option "S", Integral Cable Assembly

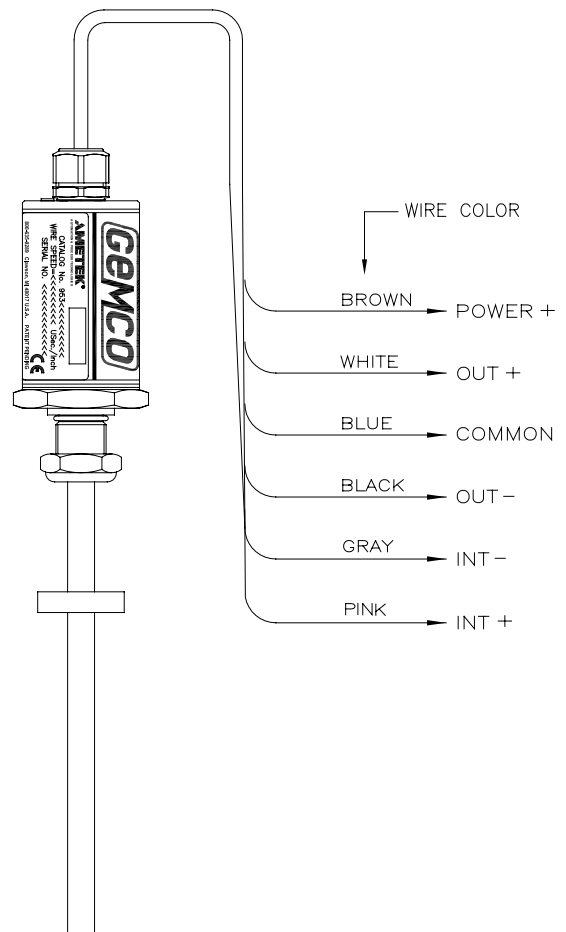

Figure 3-8: Wiring for Connector Option "C", Integral Cable Assembly

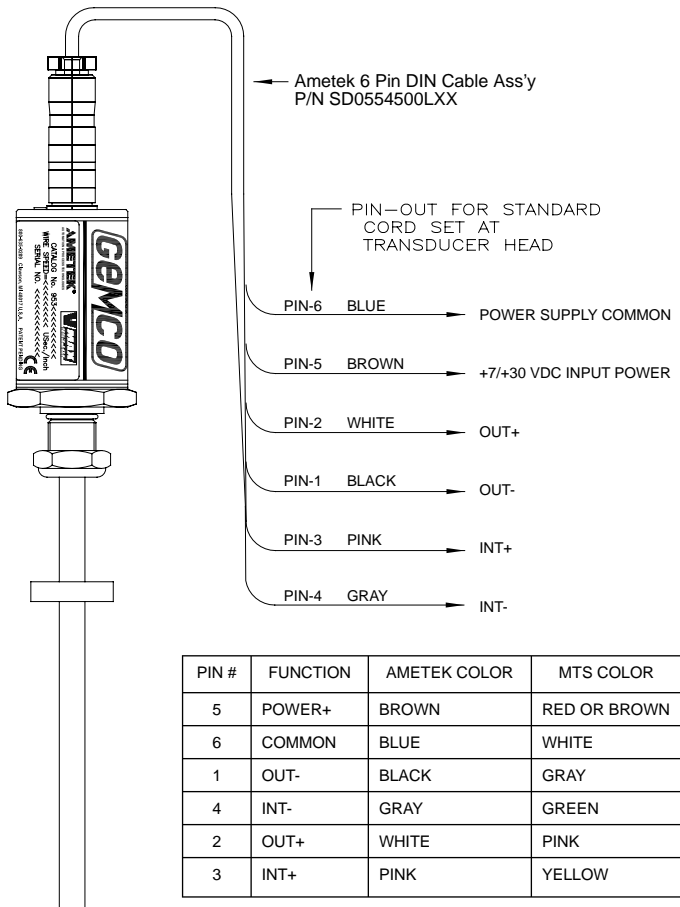

Figure 3-9: Wiring for Connector Option "M", 6 Pin DIN

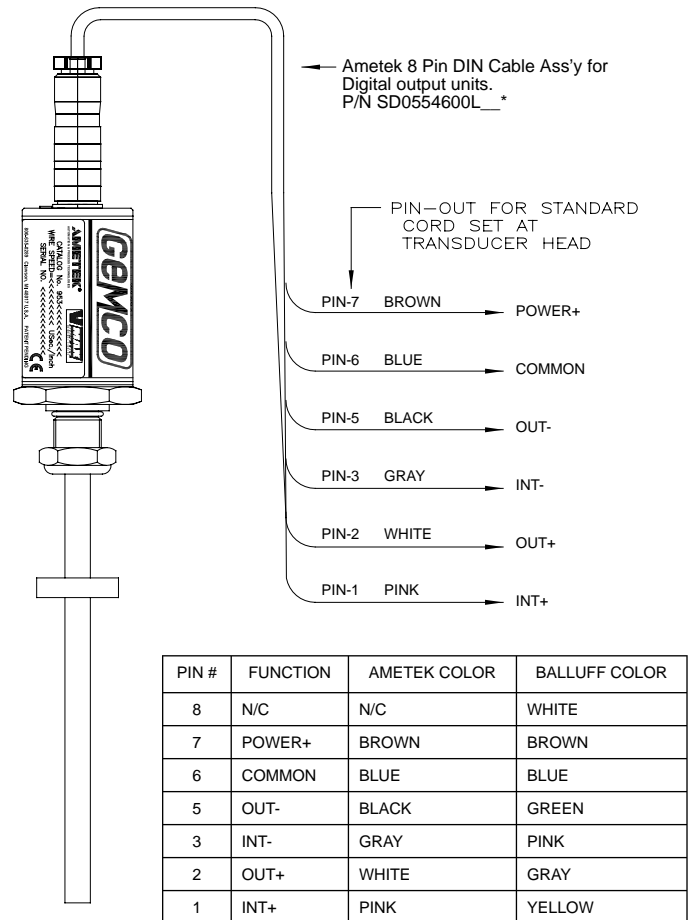

Figure 3-10: Wiring for Connector Option "B", 8 Pin DIN



### 3.6 Troubleshooting for 953D

Troubleshooting describes common problems that may occur when installing the LDT and offers possible solutions to these problems. If, after reading this appendix, you are unable to resolve a problem, contact our technical support department at 1-800-635-0289.

#### General Checks

Make sure that the magnet is located within the LDT's active stroke area. Magnet assemblies should be positioned so that they can move freely over the entire area of the active stroke without binding or pushing on the rod.

**NOTE:** Ferromagnetic material (material readily magnetized) should be located no closer than 0.25" from the sensing surface of the LDT. This includes mounting brackets, magnet spacers, magnet brackets, and mounting screws. Ferromagnetic material can distort the magnetic field, causing adverse operation or failure of the LDT.

Check all LDT wires for continuity and/or shorts. It is preferable that the cable between the LDT and the interface device be one continuous run. If you are using a junction box, it is highly recommended that the splice junction box be free of AC and/or DC transient-producing lines. The shield should be carried through the splice and terminated at the interface device end.

#### Power Supply Check

This will help you to determine if your power supply is adequate for the LDT to operate properly, or if the LDT's cable has a short or open.

In order for the 953D to operate properly, the external power supply must provide a level between 7 to 30 VDC. A power supply providing voltage above this specified range may damage the LDT. A power supply providing power below this specified range will not be sufficient to power the LDT. When powering more than one VMAX on a single power supply, remember that each VMAX typically requires 1 watt of power\*. The amount of current draw will vary based on the input voltage used. To calculate the current draw for a particular LDT, divide the LDT wattage by the input voltage. For example, 1 watt divided by 24 VDC equals 40mA.

If your LDT is not operating properly, the LDT's cable may have an open or short, or the power supply is not supplying sufficient power. To verify this, perform the following steps:

1. Turn the power supply off.
2. Remove the mating connector from the LDT.
3. Turn the power supply on.
4. Using a digital voltmeter, check from the Power Supply Common to the Power Supply + on the mating end of the cable for a level between +7 and +30 VDC.

If reading is between 7 and 30 VDC, turn power supply off and go to step 7. If reading is below 7 VDC, either your power supply is not providing enough power or the LDT's cable possibly has a short/open. Readings of no voltage or minimal voltage (less than 5 volts) may be due to short/open in the cable. If reading is **NOT** between 7 and 30 VDC, go to step 5. If reading is above 30 VDC, adjust power supply or replace.

5. Turn the power supply off.
6. Check the continuity of the individual wires of the cable between the power supply and the LDT. Check for continuity from one end of the cable to the other. Also verify that no shorts exist between pins.
7. Reconnect the mating connector to the LDT.
8. Turn power supply on.
9. Using a digital voltmeter, check the power supply's "+" and "-" terminals for a voltage between 7 and 30 VDC.

Low voltage readings may indicate a power supply with a wattage (current) rating that is too low. (Each LDT requires approximately 1 watt). If the cabling checks out in step 6 and your voltage is below 7 VDC, check your power supply current rating. If voltage is between 7 to 30 VDC and the LDT is still inoperative, contact factory.

\* See Appendix A: Specifications for more information on power consumption.



### 3.7 Part Numbering System

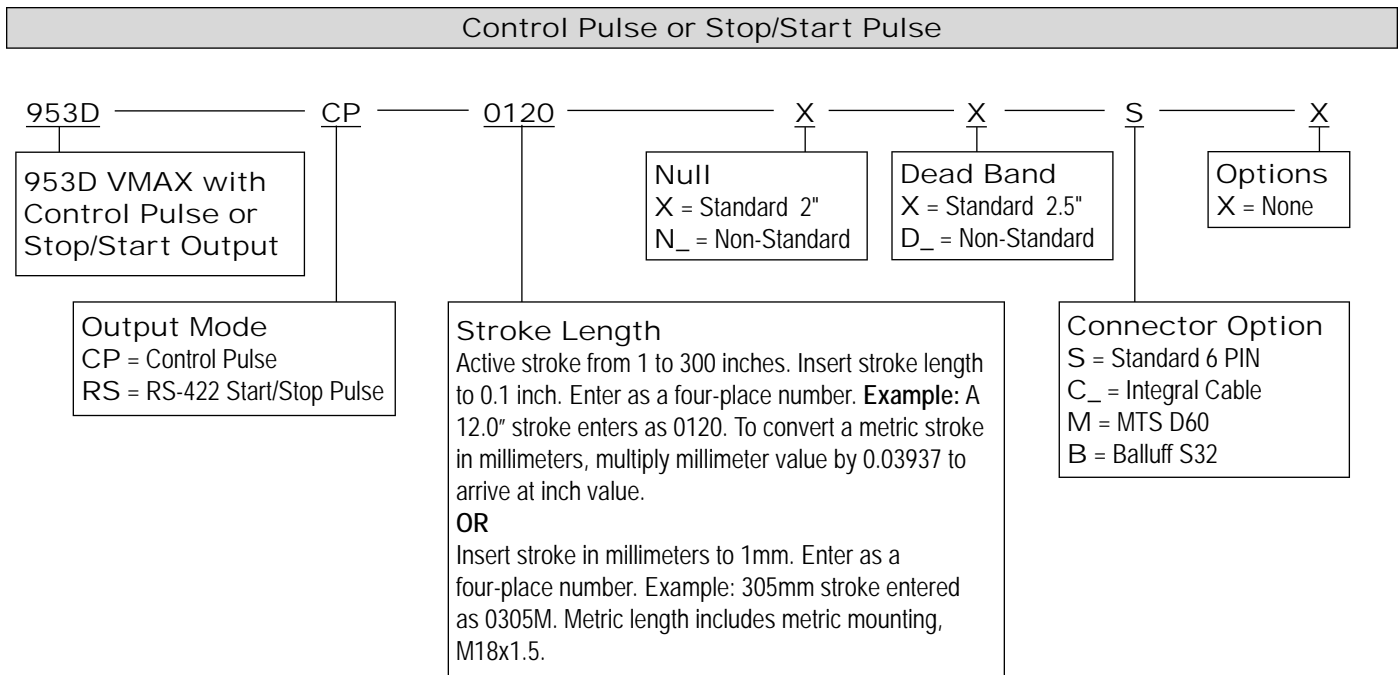
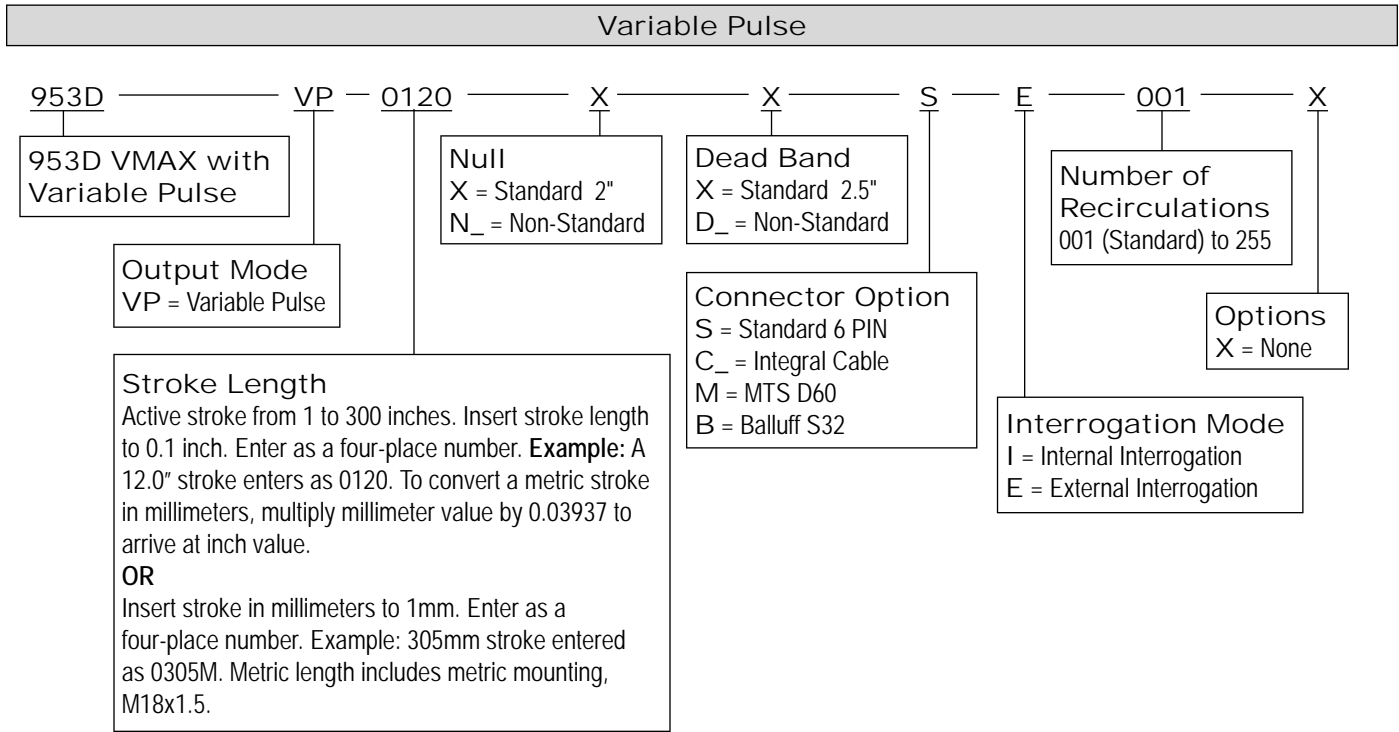

**NOTE:** Contact our Technical Support at 1-800-635-0289 for custom configurations.



## Appendix A: Specifications

General Specifications	
<b>Rod End</b>	316 Stainless Steel, 0.405" (10.29 mm) outer diameter
<b>Mounting Hex</b>	316 Stainless Steel, 1.75" (44.45 mm) across flats, IP68
<b>Mounting Threads</b>	3/4" (19.05 mm) x 16 x 1.00" (25.4 mm) with ESNA jam nut and O-ring seal optional
<b>Head Assembly</b>	Thick wall aluminum cover with Viton O-ring standard, gasket seal at the base and connector exit, IP68 IEC 600529, stainless steel cover optional
<b>Head Enclosure</b>	3.2" (81.3 mm) long with 1.75" (44.45 mm) diameter
<b>Connector</b>	6 pin 12mm Euro/Micro, standard; 6 Pin DIN and 8 Pin DIN optional
<b>Displacement</b>	Up to 300"
<b>Dead Band</b>	2.50" (63.5 mm) standard
<b>Null Zone</b>	2.00" (50.8 mm) standard
<b>Approvals</b>	CE (EMC)

Electrical Specifications	
<b>Input Voltage</b>	7-30 VDC
<b>Power Consumption</b>	One watt typical at 1ms interrogation time with no recirculations. Faster interrogation times and/or recirculations increase power consumption.
<b>Linearity</b>	Less than +/- 0.01% or +/- 0.005", whichever is greater.
<b>Resolution</b>	Controller Dependant
<b>Hysteresis</b>	0.001"
<b>Operating Temperature</b> Head (Electronics) Guide Tube	-40° to 185° F (-40° to 85° C) -40° to 221° F (-40° to 105° C)
<b>Storage Temperature</b>	-40° to 221° F (-40° to 105° C)
<b>Operating Pressure</b>	3,000 psi constant, 8,000 psi spike
<b>Guide Tube Pressure</b>	5,000 psi constant, 10,000 psi spike
<b>Shock &amp; Vibration</b> Shock Vibration	1,000Gs (lab tested) IEC 60068-2-27 30Gs (lab tested) IEC 60068-2-6
Specifications are subject to change and based on a typical 48" stroke length.	



Other Products		

Copyright 2007 by AMETEK Automation & Process Technologies. All Rights Reserved. Made in the USA.



1080 N. Crooks Road, Clawson, MI 48017-1097  
 Phone: 248.435.0700 Toll Free: 800.635.0289  
 Fax: 248.435.8120 [www.ametekapt.com](http://www.ametekapt.com)

953.MOR  
 6/07.Z274

