

AMETEK[®]

Series 2110
GEMCO[®]
Shut Height Monitor



Shut Height Monitor with Resolver/LDT Interface Installation and Programming Manual

Spec Tech Industrial 203 Vest Ave. Valley Park, MO 63088 Phone: 888 SPECTECH
Email: sales@spectechind.com www.spectechind.com



AUTOMATION & PROCESS TECHNOLOGIES

1080 North Crooks Road

Clawson, MI 48017-1097

Phone: (248) 435-0700

FAX: (248) 435-8120

Internet: www.ametekapt.com

www.ametek.com

Preface

This manual is divided into three parts. Part 1 provides an introduction and installation instructions for Series 2110 Shut Height Monitor. Part 2 contains instructions for the basic operation and programming of the monitor. Part 3 contains four appendixes: Error Messages, Function Summary Chart, Catalog Numbering System, and Specifications. A glossary and index are also provided at the back of this manual.

Disconnect power before servicing. The Gemco Series 2110 contains no servicable components other than the power supply fuse. Consult factory for repair or replacement.

Copyright 1997, 1998, 1999 by AMETEK, Inc.

All Rights Reserved - Made in the U.S.A.

Version 0.3

Ametek has checked the accuracy of this manual at the time it was printed. Any comments you may have for the improvement of this manual are welcomed.

Ametek reserves the right to revise and redistribute the entire contents or selected pages of this manual. All rights to the contents of this manual are reserved by Ametek.

Contents

Chapter 1: Theory of Operation	1
Chapter 2: Hardware Overview	
2.1: Standard Modules	2
Controller (FMMP01)	3
Relay Output (FMOR01)	3
Digital Output	3
Power Supply (FMPS01)	3
2.2 Input Module	4
Resolver (FMIR01)	4
Variable Pulse (FMIP01)	4
LDT Input (FMIP02)	4
2.3 Status LED's/Programming Keys	5
Chapter 3: Mounting and Wiring	7
Things to Consider	7
3.1: Mounting & Section	7
Controller	7
Resolver	8
LDT	8
Cabling V1 Option	8
3.2: Wiring.....	11
Controller Module (FMMP01)	11
Relay Output Module (FMMP01)	11
Power Supply Module (FMPS01).....	12
Resolver Module (FMIR01)	13
Variable Pulse LDT Module (FMIP01) Input Option V1.....	13
LDT Input (FMIP02) Input Option L1	14
Chapter 4: Programming.....	18
Before Getting Started	18
Programming Keys Defined	19
4.1: Resolver Configuration Functions	20
Scale Factor (300)	20
Turns Counting (301)	21
Position Offset (302)	21
Configuring the Resolver	21
Enter Scale Factor for the Configuration Process	22
Set Turns Counting to 1	22
Set the Position Offset to 0	23
Enter Newly Determined Scale Factor	23

Adjust the Turns Counting Factor	23
4.2: LDT Configuration Function	24
Wire Speed (300)	24
Count Direction (301)	26
Position Offset (302)	27
Zero Pulse Time (305)	27
Fault Pulse Time (306)	28
LDT Output Type (307)	28
4.3: Monitor Setup Functions	29
Unit of Measurement (14)	29
Decimal Location (13)	30
Position Hold (15)	30
Auxiliary LED (16)	31
4.4: Press Setup Functions	32
Move Detection Time-Out (12)	32
Bolster Offset (303)	33
Negative Over Travel Limit (304)	33
Upper End Limit (400)	34
Lower End Limit (401)	34
Relay State (402)	35
Relay Override (403)	35
4.5: Digital Outputs	36
Output Type (200)	36
Latch/Synchronize Handshake (201)	37
Logic Level (202)	37
Error Condition Output State (203)	38
4.6: Program and Supervisory Mode Functions	41
Program Mode Access (10)	41
Program Mode Time-Out (11)	42
Appendix A: Error Messages.....	43
Error Conditions (306)	48
Appendix B: Function Summary Chart	49
Appendix C: Catalog Numbering System	51
Appendix D: Specifications	52
Glossary	53
Index	55

Chapter 1: Theory of Operation

The Series 2110 shut height monitor accurately indicates shut height positions to quickly and accurately assist setup personnel in changing a die on a mechanical stamping press. Positions can be monitored within a thousandth of an inch. During a die change, the monitor displays the position of the press's shut height on a large LED display. If the shut height is moved beyond its programmed end limits, the monitor de-energizes a limit switch. (This will only occur if the optional relay module is installed.) This limit switch can work in conjunction with the safety interlock of the press. For example, when wired properly, power will be removed from the press's ram adjust motor(s).

The monitor can also stop updating the shut height during a press's stamping cycle while retaining the last shut height read. This is used to filter out press movement and deflection during the stamping cycles. When power is applied to the input, the monitor holds the displayed shut height on the read out. When this input is released, the monitor continuously updates the display with the current shut height position.

A built-in timer is also included which is used to detect a possible jam or drive component failure. The timer starts when power is applied to the ram adjust motor(s) and stops when the monitor senses motion from the input device. If the ram does not move within a programmed value, the monitor de-energizes limit switches and displays an error message. When properly wired to the safety interlock of the press, the limit switches de-energizing will take power away from the press's ram adjust motor(s).

Other features of the shut height monitor include the following:

- Measures in inches or millimeters.
- Program mode access code protects against unauthorized access.
- Separate bolster plate offset speeds setup.
- States of the limit switches can be changed for N.O. and N.C. operations.

Chapter 2: Hardware Overview

The shut height monitor contains a heavy-duty case which can hold up to five modules:

- Power Supply
- Controller (CPU)
- Digital Output (optional)
- Analog Output (optional)
- Resolver Input (optional)
- Linear Displacement Transducer L1 (optional)
- Linear Displacement Transducer V1 (optional)
- Relay Output (optional)

The shut height monitor's faceplate contains a 6-digit, seven-segment LED display and four programming keys. The LED display is used to indicate the shut height position as well as to enter parameters when programming. The programming keys are used to program the monitor. Ten small status LEDs are also provided. These LEDs are used to indicate the state of the monitor during machine operation.

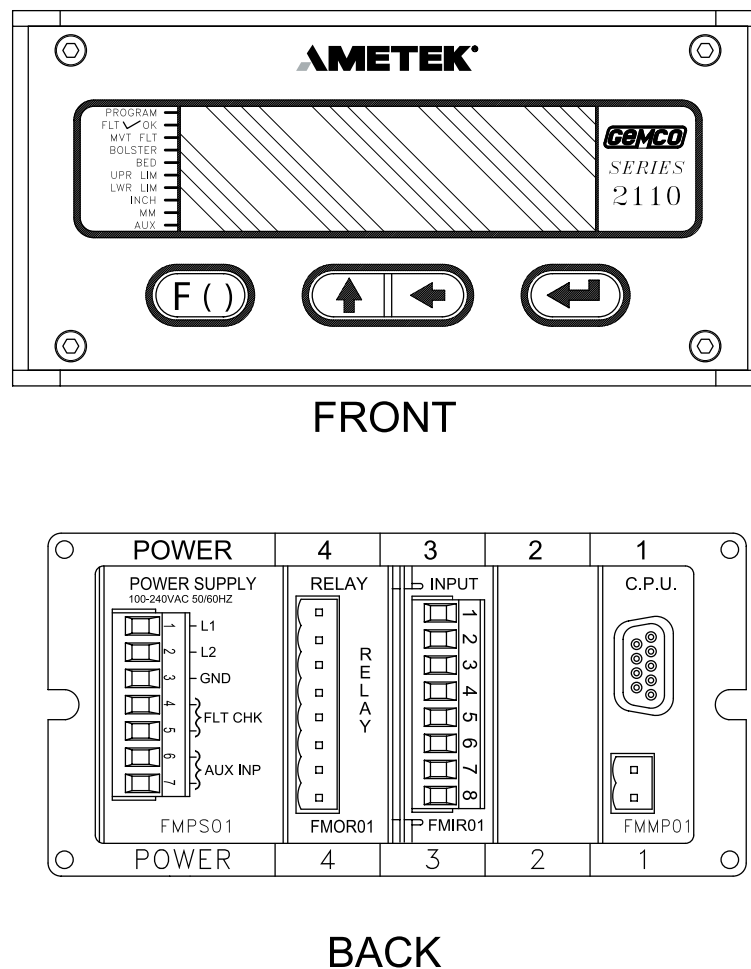

Figure 2-1 Shut Height Monitor

2.1: Standard Modules

This section provides descriptions of the shut height monitor's standard modules. See also Section 2.2: Input Modules. For wiring instructions, see Section 3.2: Mounting & Wiring.

Controller (FMMP01)

This module contains the Central Processing Unit (CPU) which is used to process data it receives from the resolver or LDT (depending on which input device is used). It then shows the position of the shut height on the monitor's display. The controller is also responsible for continuously monitoring all programmed setpoints and timing functions. To store programmed functions, including calibrated settings, the controller contains battery-backed memory. This battery requires no maintenance and is non-replaceable. The controller is located in slot 1 of the enclosure.

Relay Output (FMOR01)

This is an optional module. It contains an upper and lower limit relay. These relays can be programmed to either energize or de-energize when the press's shut height reaches either of the relay's programmed limits. When these relays are programmed to de-energize and are wired properly, power will be taken away from the press's ram adjust motor(s). For a listing of errors which will cause the upper and lower limit relays to de-energize, see Chart A-5 in Appendix A: Error Messages. The relay output module is located in slot 4 of the enclosure.

Power Supply (FMPS01)

This module supplies power to the shut height monitor. It also contains a fault check relay and an auxiliary input. The fault check relay is designed to take power away from the press's ram when a fault occurs during machine operation, or when power is taken away from the monitor. In order for this to work, the fault check relay must be properly wired to the press's safety interlock. For a listing of errors which will cause the fault check relay to open, see Chart A-4 in Appendix A: Error Messages. The auxiliary input is used with the press's ram adjust motor(s). When used with the Move Detection Time-out function, this input can detect a possible jam or drive component failure when power is applied from the motor(s) but no movement occurs. When used with the Position Hold function, this input can be used to stop the monitor from updating the shut height during a press's stamping cycle. The auxiliary input accepts 85-265 VAC. The power supply is located in slot 5 of the enclosure.

Digital Output (FMOD01) Output Option D1, D2 or D3

This module is used to transmit parallel digital output data to a PLC or personal computer. The digital output is field configurable for position or velocity data in a binary, BCD or grey code format. This data is updated every 50 microseconds for resolver input and 40 milliseconds for LDT input. The electrical characteristics of this output data can be current sinking, current sourcing or TTL, which must be specified in the module's part number.

This module also provides two input pins for use as a field configured latch or synchronized handshake input. The latch input freezes the digital output data while the PLC reads it. The data is updated when the input is released. When configured for synchronized handshake, the PLC must provide a clocked square wave input into these input pins. Digital data is updated on each transition of the square wave and the PLC is synchronized to read the updated position data after a 100 microsecond settling time.

This input accepts a 5 to 24 VDC source from the PLC to perform the latch or synchronized handshake function described above. For details on wiring to the digital output board, see pages 16 & 17.

Analog Output (FMOA01) Output Option A1

This module is used to transmit position or velocity data to a PLC in an analog format. The module provides two separate analog output channels that can be independently configured for position or velocity data.

These analog outputs can be field scaled over any range and configured for 0 - 10 VDC, 10 - 0 VDC, -10 VDC to +10 VDC, 4 - 20 mA, 20 - 4mA, 0 - 20 mA or 20 - 0 mA.

For applications that require remote indication it is recommended to use an aftermarket analog input display or a digital input display. When using one of these displays the optional analog or digital output board must be specified in the part number.

2.2: Input Modules

The shut height monitor can be used with a resolver or Linear Displacement Transducer (LDT). Both input devices' input modules are located in slot 3 of the enclosure. You can identify the module type by the name found on the back of the module.

Resolver (FMIR01) Input Option R1

This module is used with a Gemco resolver. The resolver assembly consists of a highly accurate and repeatable brushless resolver, housed in an industrial-grade enclosure. The shaft position is calculated from two analog signals that vary as a function of the angular rotation of the input shaft.

The brushless resolver works on the same principle as a rotary transformer to couple power into the rotor. The construction of the brushless resolver consists of a two-phase stator and a single-phase rotor. Each stator is positioned 90° apart from each other. The two stators continually provide two different output voltages. Using these two outputs, the module performs a ratiometric conversion and provides an absolute position. This results in a highly accurate and repeatable transducer having excellent reliability with an infinite resolution which can be converted by a resolver-to-digital converter into digital position data.

Variable Pulse (FMIP01) Input Option V1

This module is used with an LDT that provides its output in the form of a pulse width modulated RS-422 signal. The module only works with Gemco 951VP2110 LDT's.

LDT Input (FMIP02) Input Option L1

This module will accept an output from a controlled pulse, start stop pulse or variable pulse magnetostrictive LDT. This card accepts a wide range of LDT inputs and faster updates than the variable pulse described above.

It allows the shut height monitor to receive the signals from the LDT. The pulse width signal is converted to position data which the monitor displays and uses for shut height position. The module also provides +24 VDC to supply power to the LDT. The monitor was designed to work with the Gemco Series 951 or 952 LDT. However, other LDTs can be used with the shut height monitor. If you are using a different type of LDT, contact the factory for wiring and programming instructions.

2.3: Status LED's/Programming Keys

The shut height monitor has 10 status LEDs and four programming keys. The LEDs provide information on the monitor's state during machine operation. The programming keys are used to program functions and perform basic operations.

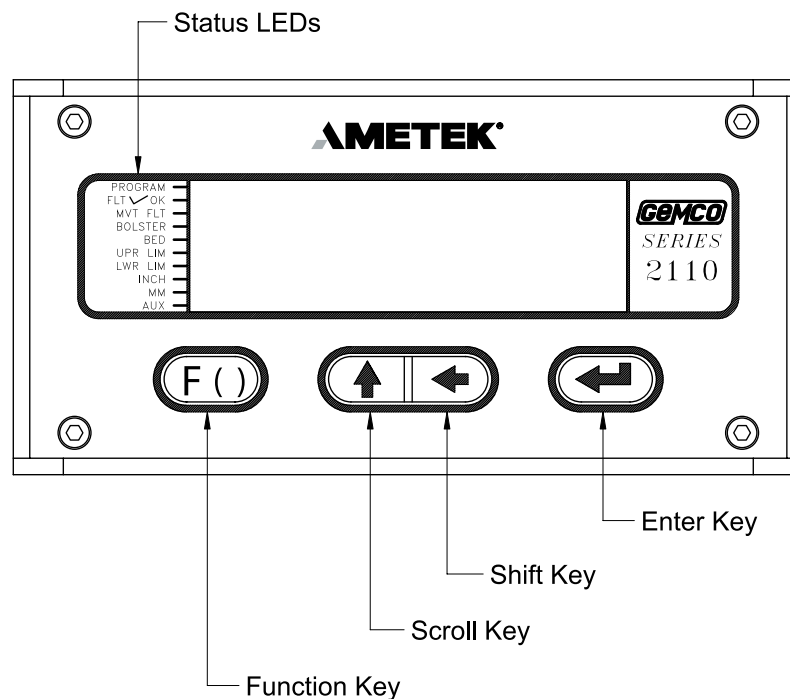

Figure 2-2: Monitor's Status LED's and Programming Keys

PROGRAM	The program LED turns on when the controller is in program mode and turns off when the controller is not in program mode. Functions cannot be programmed when this LED is off.
FAULT ✓ OK	The fault check OK LED turns on when the power supply's fault check relay is closed, indicating the system is OK. This LED will turn off when a fault is detected, indicating that the fault check relay is open.
MVT FLT	The movement fault LED turns on when a movement fault is detected. (For more information, see Move Detection Time-Out in Section 4.4: Press Setup Functions.)
BOLSTER	This LED indicates that the current shut height position is referenced from a bolster plate. The bolster LED turns on when a value is programmed into the Bolster Offset function. (For more information, see Bolster Offset in Section 4.4: Press Setup Functions.)
BED	This LED indicates that the shut height position displayed on the monitor is referenced from the press's bed. The bed LED turns on when the Bolster Offset function contains a 0 value. (For more information, see Bolster Offset in Section 4.4: Press Setup Functions.)
UPR LIM	The upper limit LED turns on when the press's shut height reaches the value programmed in the Upper End Limit function. (For more information, see Upper End Limit in Section 4.4: Press Setup Functions.)
LWR LIM	The lower limit LED turns on when the press's shut height reaches the value programmed in the Lower End Limit function. (For more information, see Lower End Limit in Section 4.4: Press Setup Functions.)
INCH	The inch LED turns on when the unit of measurement is in inches.
MM	The millimeter LED turns on when the unit of measurement is in millimeters.
AUX	The auxiliary LED is programmable and can be used with the Position Hold function. When enabled, this LED indicates when the shut height position is being held. (For more information, see Position Hold and Auxiliary LED in Section 4.3: Monitor Setup Functions.)



The function key is used to begin a process for programming a function. When this key is pressed, the monitor prepares itself for the entry of a specific function number.



The scroll key is used to scroll through the monitor's list of function numbers, as well as other lists. This key is also used to increment selected digits shown on the monitor's LED display.



The shift key is used to move to (select) a specific digit shown on the monitor's LED display from right to left.



The enter key is selected after a function number has been entered. This begins the programming process for the selected function. The enter key is also used to program a value in a function.

NOTE: For more information on how to use the programming keys, see Chapter 4: Programming.

Chapter 3: Mounting and Wiring

This chapter provides instructions for mounting and wiring the shut height monitor. These instructions have been divided into two sections: Section 3.1: Mounting and Section 3.2: Wiring.

Things to Consider

It is recommended that you consider the following before installing the shut height monitor:

- To minimize the effects of electromagnetic interference (EMI), the monitor should be mounted as far away as possible from motor starters and control relays.
- The monitor should be mounted in an area free of water spray, corrosive gases, flying chips, or any other foreign matter that could cause damage to the unit.
- If the monitor is mounted directly on the press, it should be installed in an area where shock and vibration will be minimized.
- The monitor should be located in an area that is within the temperature and humidity specifications. (See Appendix D: Specifications.)

3.1: Mounting

Controller

To assist you in mounting the shut height monitor, refer to Figure 3-1. Perform the following steps:

1. According to the dimensions as shown in Figure 3-1, cut out a section of the panel you wish to mount the monitor to.
2. Remove the mounting rails on the left and right side of the unit by removing the #6-32 UNC screws located on the rear of the unit.
3. Place the monitor in the newly cutout section of the panel.
4. From behind the panel, insert the two mounting rails into the monitor's side grooves. The feet of the rails must be inserted first. See Figure 3-1 for the location of the mounting rails.

The mounting rails secure the monitor by their feet being pressed against the back of the panel.

5. Insert each #6-32 UNC screw into each of the monitor's screw holes.
6. Using a 7/64" Allen wrench, secure the screws into position. This will secure the mounting rails. Eight to 10 inch pounds of torque is required.

Resolver

The resolver is mounted and coupled to the main ram adjust drive motor, or another shaft that rotates when the shut height is adjusted.

NOTE: Backlash and slop in the shaft will affect shut height accuracy.

LDT

The LDT is mounted on the upper pitman arm of the press with the sensing rod facing down and next to the upper ram. The magnet assembly is mounted off the upper ram per the drawing - see Figure 3-2. Universal mounting kit (SD0441300) will simplify mounting of LDT to the upper pitman arm. See Figure 3-2A for a typical mounting example.

Cabling

Since the LDT rides with the upper ram, a method must be found to control the cable during a press cycle.

AMETEK manufactures several cable termination kits which provide a junction box mounted to the crown of the press and a coiled cord set that protects the cable and its connection to the junction box and the LDT or resolver. (See Figure 3-2B for general mounting details).

Select the appropriate cable termination kit from the variations listed below.

- 1) Magnetostrictive LDT used with type **V1** input on series 2110 module.
Catalog No. SD0482700L25
- 2) Magnetostrictive LDT used with type **L1** input on series 2110 module.
Catalog No. SD0443800L25
- 3) Resolver used with type **R1** input on series 2110 module.
Catalog No. SD0439600L25

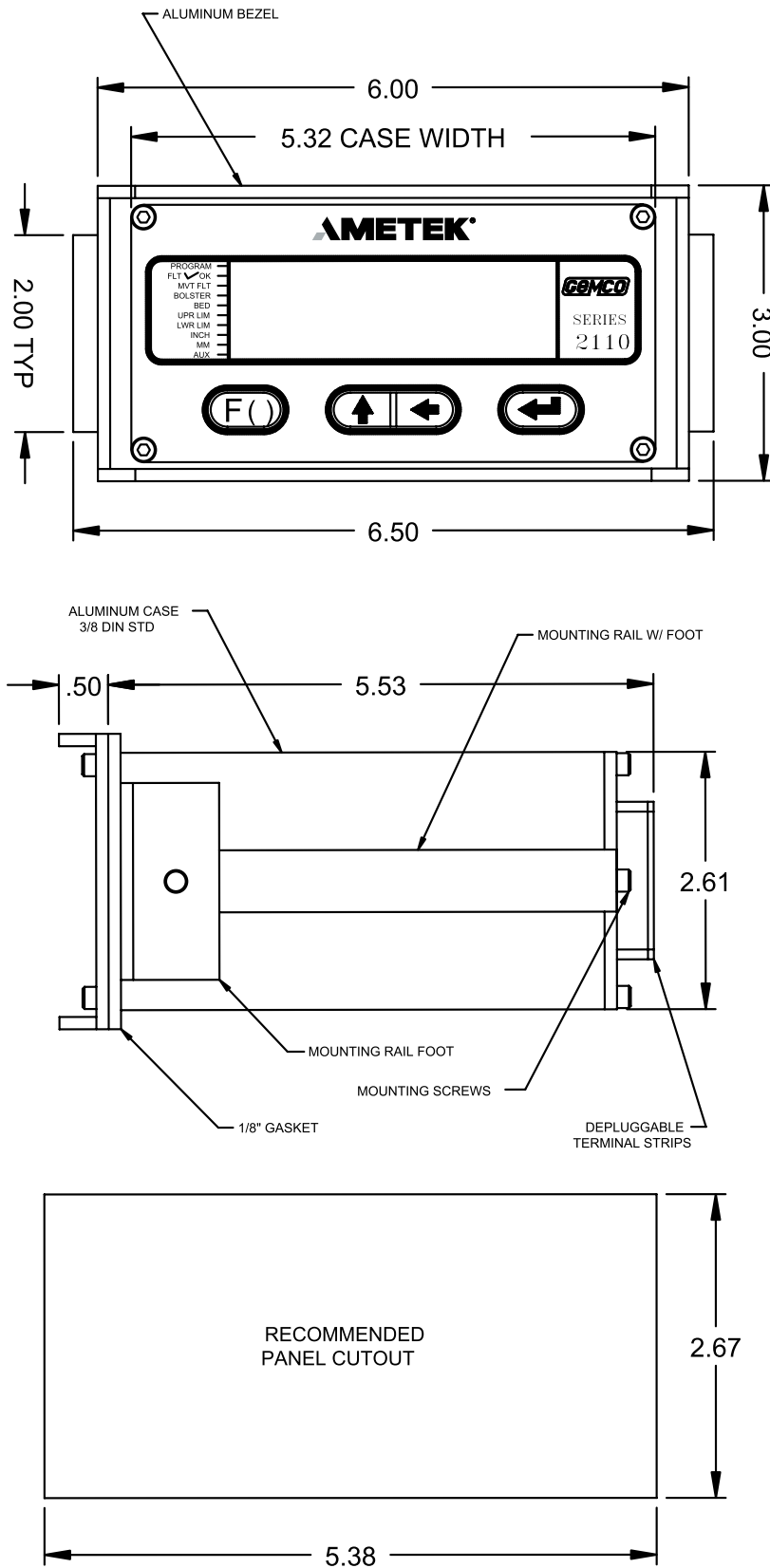

Figure 3-1 Dimensional Drawing

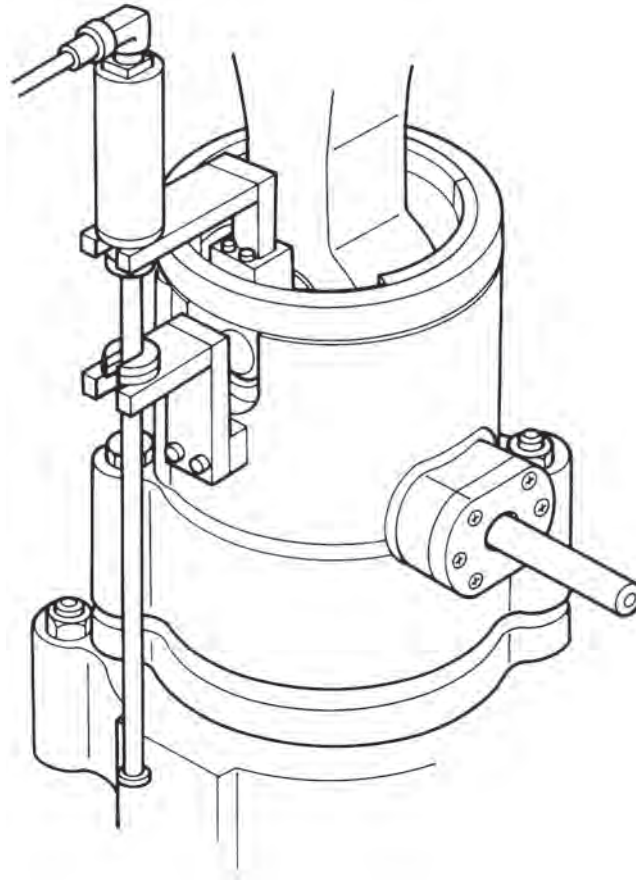

Figure 3-2 Transducer Mounting

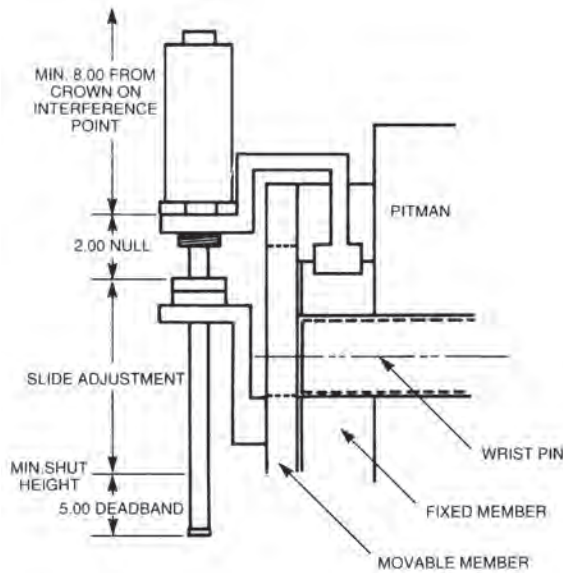

Figure 3-2A Universal Mounting Kit

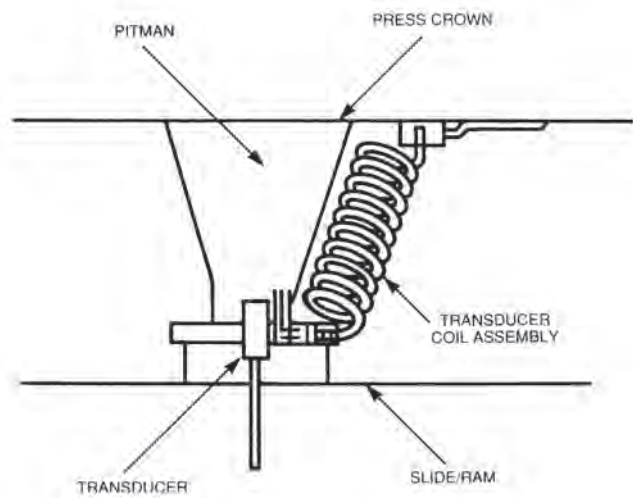

Figure 3-2B Termination Kit

3.2: Wiring

This section contains pinout diagrams for each module. System wiring diagrams follow.

Controller Module (FMMP01)

The controller has two connectors: a D9 connector (J1) for RS-232 and RS-485 serial communications, and a program lockout connector (J2) intended for a keyswitch. (See Figure 3-3). Making connections to both connectors is optional. However, the program lockout connector must be jumpered to allow the unit to enter program mode. J2's input rating is +5 VDC maximum dry contact or open collector (drain) only. Actuation voltage must be less than +1.0 VDC at 0.2 mA. The terminal wire size is No. 22-12 AWG.

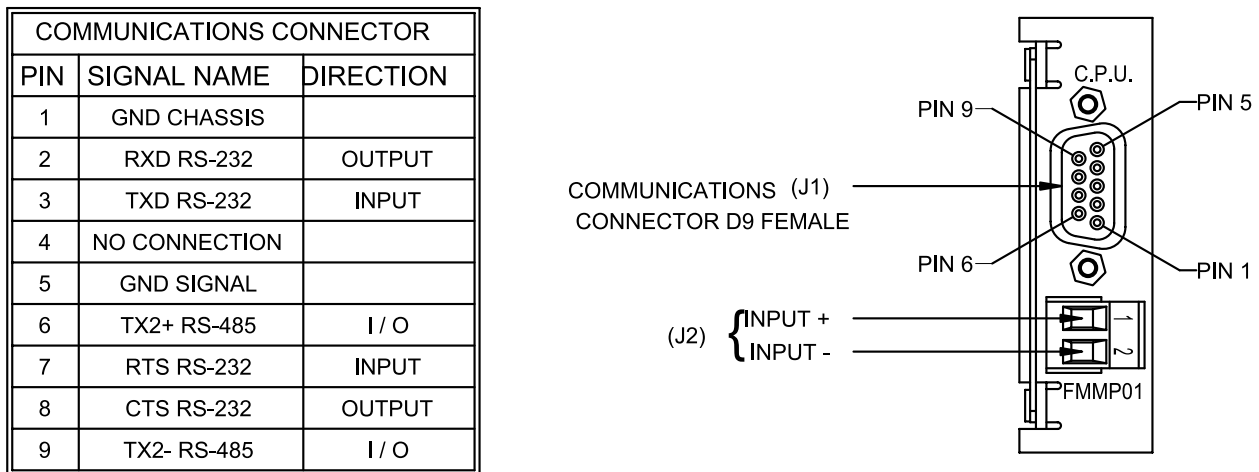

Figure 3-3 Controller Pinout Diagram

NOTE: (J2) program lockout connector.

NOTE: The controller's program lockout connector (J2) must be jumpered to allow the unit to enter program mode.

Relay Output Module (FMOR01)

The relay output module contains an upper and lower limit relay. Each relay contains a N.O. contact pair and a separate N.C. contact pair. (See Figure 3-4). Each relay contact rating is 8 amps, 250 VAC, 30 VDC, 1/4 HP 125, 250 VAC. It is recommended that you connect these relays to the ram adjust motor control circuit to prevent movement beyond the programmed upper and lower limits. The terminal wire size is No. 22-12 AWG.

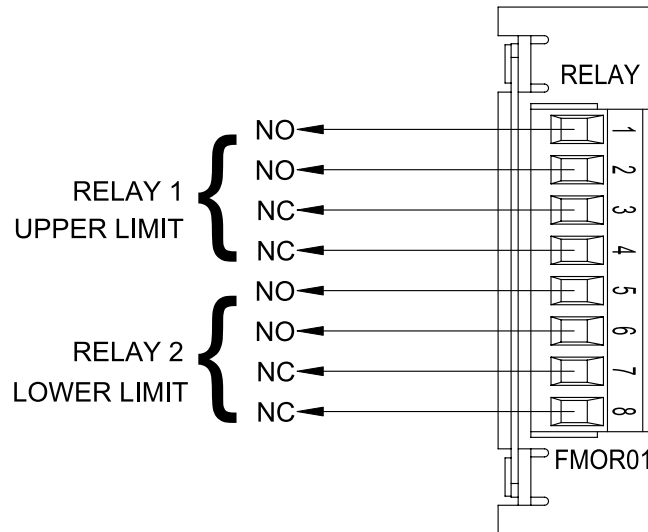

Figure 3-4 Relay Output Pinout Diagram

Power Supply Module (FMPS01)

The power supply module has a main power input, an auxiliary input, and a fault check output. (See Figure 3-5). Power input: 85-265 VAC at 450 mA maximum. Fault check output: 8 amps 250 VAC, 30 VDC, 1/4 HP 125, 250 VAC. It is recommended that the fault check contacts be connected to the required safety interlock for the press. Auxiliary input: 85-265 VAC at 12 mA maximum. The terminal wire size for all connectors is No. 22-12 AWG. See page 3, 35, 36 and 37 for use of this special purpose input, concerning position hold and move detection.

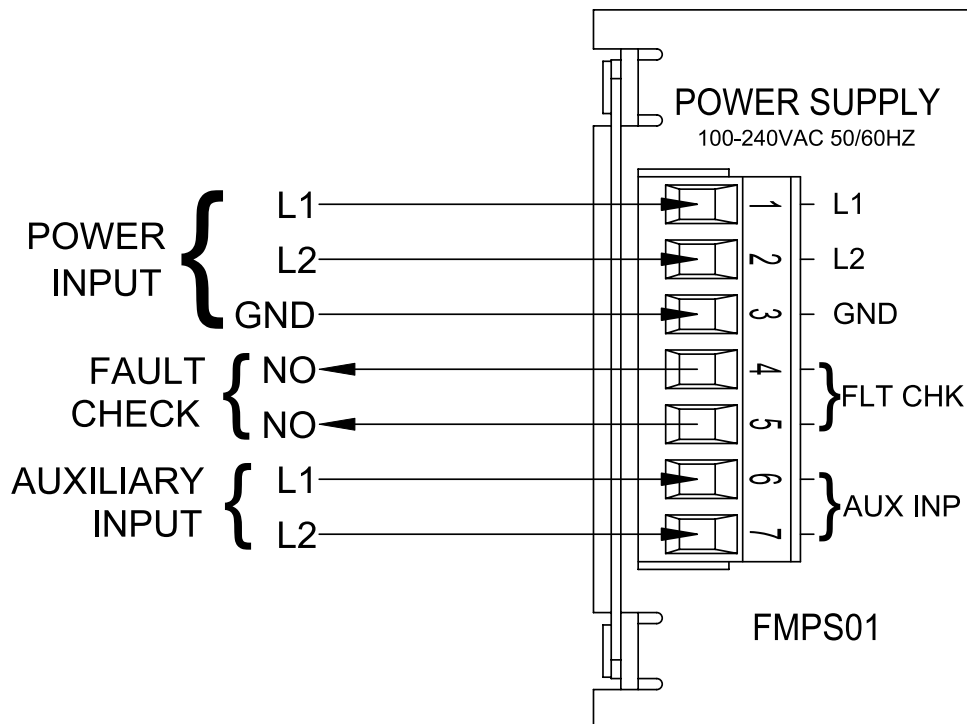

Figure 3-5 Power Supply Pinout Diagram

Resolver Module (FMIR01)

The resolver module has an eight-position connector. (See Figure 3-6). The terminal wire size for all positions is No. 22-12 AWG. Terminal 7 and 8 are not used.

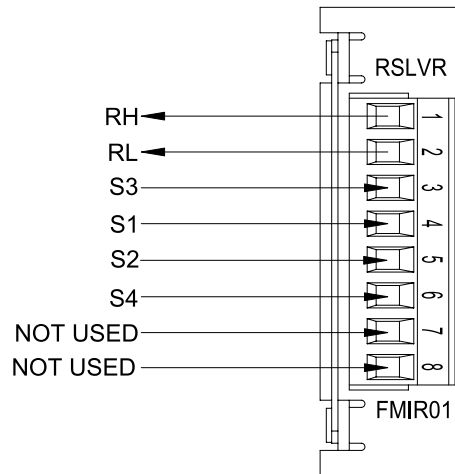

Figure 3-6 Resolver Pinout Diagram

Variable Pulse LDT Module (FMIP01) Input Option V1

The variable pulse LDT module has an eight-position connector. It is only necessary to connect your LDT to positions 1 through 4. (See Figure 3-7). Positions 1 and 2 provide +24 VDC to power the LDT. Positions 3 and 4 are used for the LDT's pulse-width output signals. These signals comprise an RS-422 differential input. Positions 5-8 are provided for future expansion. The terminal wire size for all positions is No. 22-12 AWG. This module should only be used with Gemco LDT model 951VP-2110 transducers.

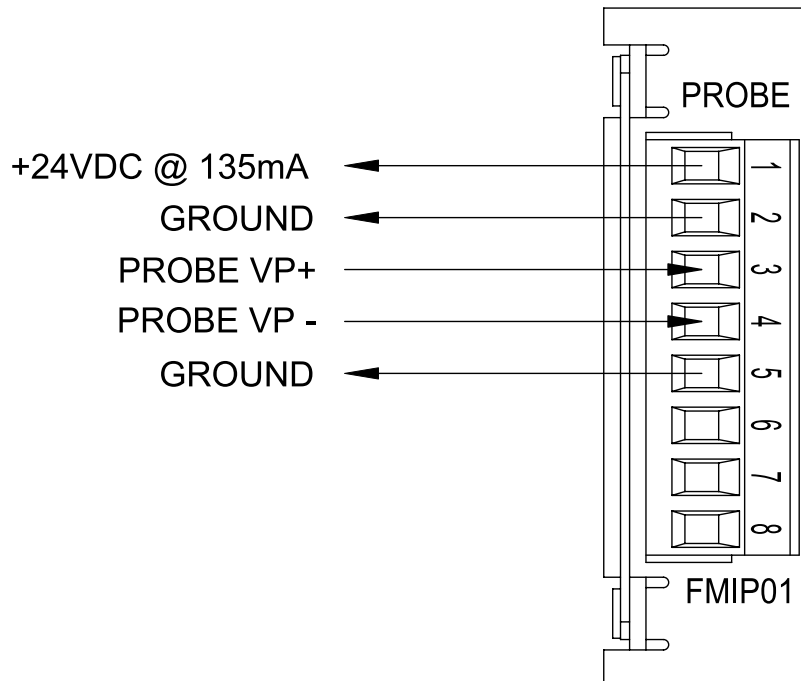

Figure 3-7 Variable Pulse LDT Pinout Diagram Input Option V1

LDT Input (FMIP02) Input Option L1

This module will accept an output from a controlled pulse, start stop pulse or variable pulse magnetostrictive LDT. (See Figure 3-7). This card accepts a wide range of LDT inputs and provides faster updates than the variable pulse module as described on page 14.

The pulse width signal is converted to position data which the monitor displays. The module also provides +24 VDC to supply power to the LDT. The monitor was designed to work with the Gemco 951 or 952CP & RS LDTs. However, other LDTs can be used with the PLC Interface Module. If you are using a different type of LDT, contact the factory for wiring and programming instructions. The terminal wire size for all positions is No. 22-12 AWG.

The reset-to-preset input is an edge sensitive input that resets position data to a preprogrammed value. A 5-24VDC source applied to these terminals activates the input. For programming of reset value, see Chapter 4: Programming.

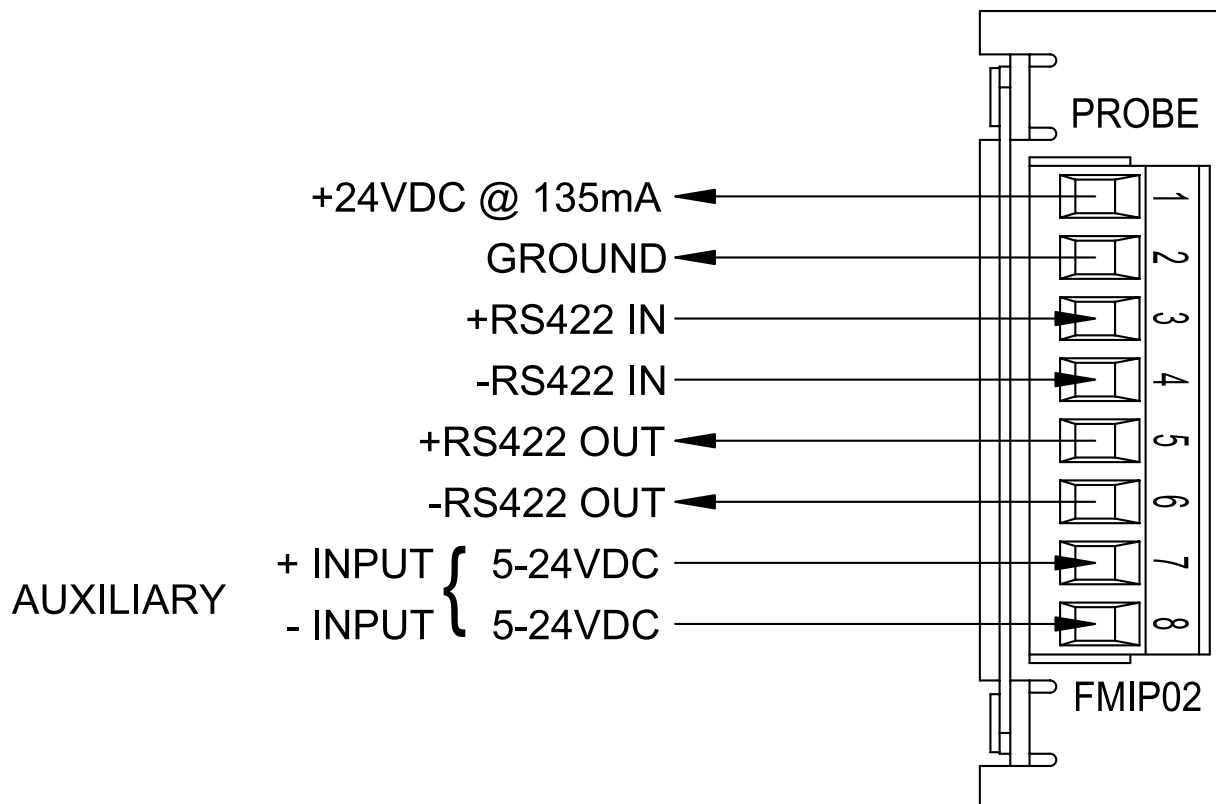
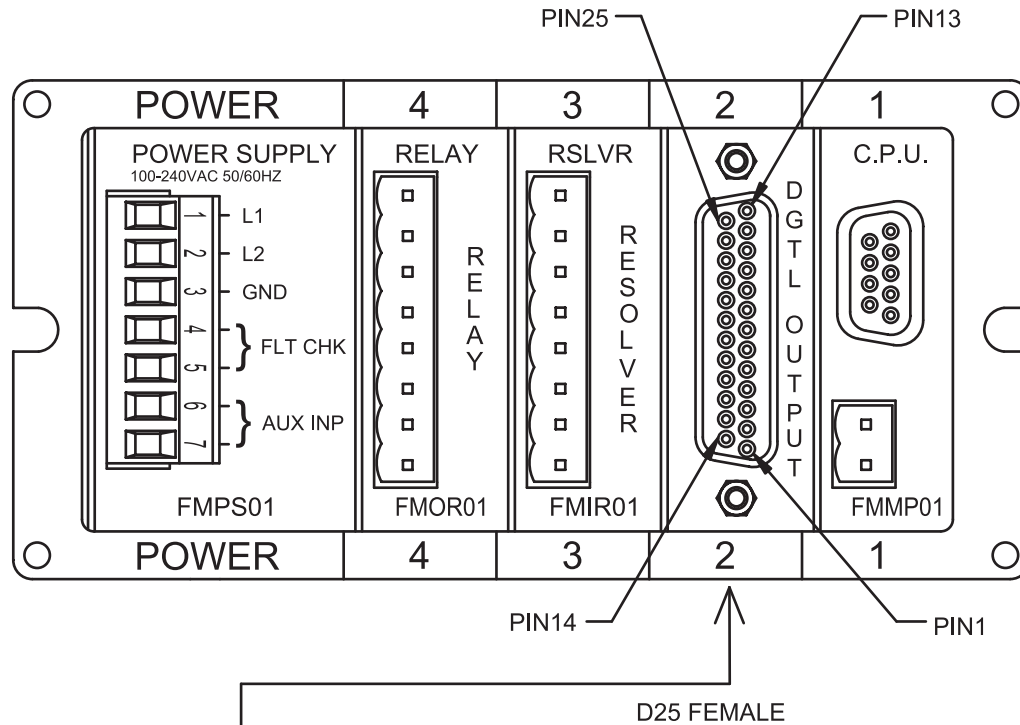

Figure 3-7 LDT Pinout Diagram Input Option L1

Digital Output (FMOD01) Output Option D1, D2 or D3

This module will output Binary, BCD, or Grey Code digital outputs in either current sinking, current sourcing, or TTL level outputs. See Fig. 3-13A & B and Fig. 3-14 for wiring details. It also contains a 5-24VDC source input for freezing the digital data while the PLC reads it. See page 42, Latch/Synchronize Handshake.



PIN	DIRECTION	DESCRIPTION
1	OUT	DATA OUT BIT 0
2	OUT	DATA OUT BIT 2
3	OUT	DATA OUT BIT 4
4	OUT	DATA OUT BIT 6
5	OUT	DATA OUT BIT 8
6	OUT	DATA OUT BIT 10
7	OUT	DATA OUT BIT 12
8	OUT	DATA OUT BIT 14
9	OUT	DATA OUT BIT 16
10	OUT	DATA OUT BIT 18
11	OUT	BUSY
12	IN	BUS ENABLE (Optional, Consult Factory)
13	COMMON	GND
14	OUT	DATA OUT BIT 1
15	OUT	DATA OUT BIT 3
16	OUT	DATA OUT BIT 5
17	OUT	DATA OUT BIT 7
18	OUT	DATA OUT BIT 9
19	OUT	DATA OUT BIT 11
20	OUT	DATA OUT BIT 13
21	OUT	DATA OUT BIT 15
22	OUT	DATA OUT BIT 17
23	OUT	DATA OUT BIT 19
24	IN	LATCH/SYNC HANDSHAKE
25	POWER	VSRC+

Figure 3-9 Digital Output Wiring Diagram
Drawing E0232200

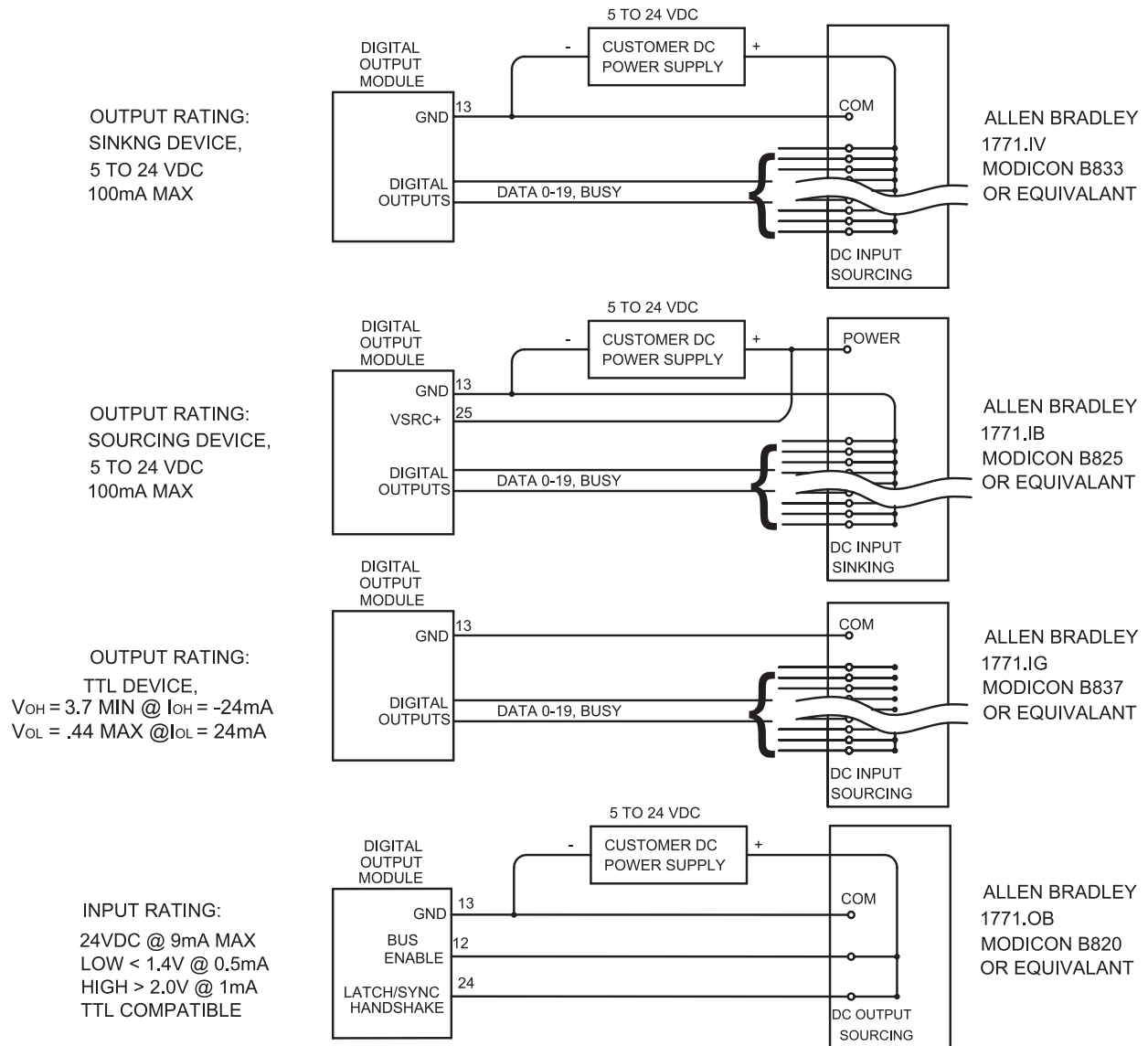
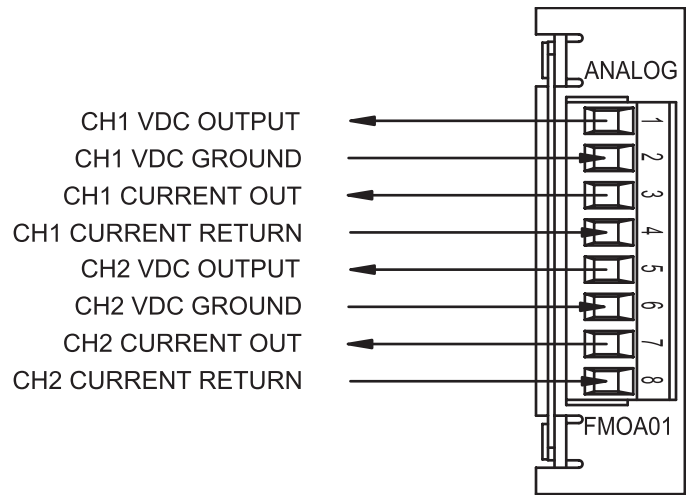

Figure 3-10 Digital Output Wiring Diagram
Drawing E0232200

Analog Output (FMOA01) Output Option A1

The Analog Output board provides two channels of analog output that can be independently configured and scaled. Each channel can be configured for an output based upon position or velocity. Velocity will be RPM if the sensor is a resolver or inches/mm per second if the input sensor is an LDT. The two channels of analog output allow you to configure one analog output to be based on position while the other channel provides a simultaneous indication of velocity.



Terminal Wire Size: No. 22-12 AWG

Figure 3-11 Pinout Diagram Analog Output
Drawing E8005099

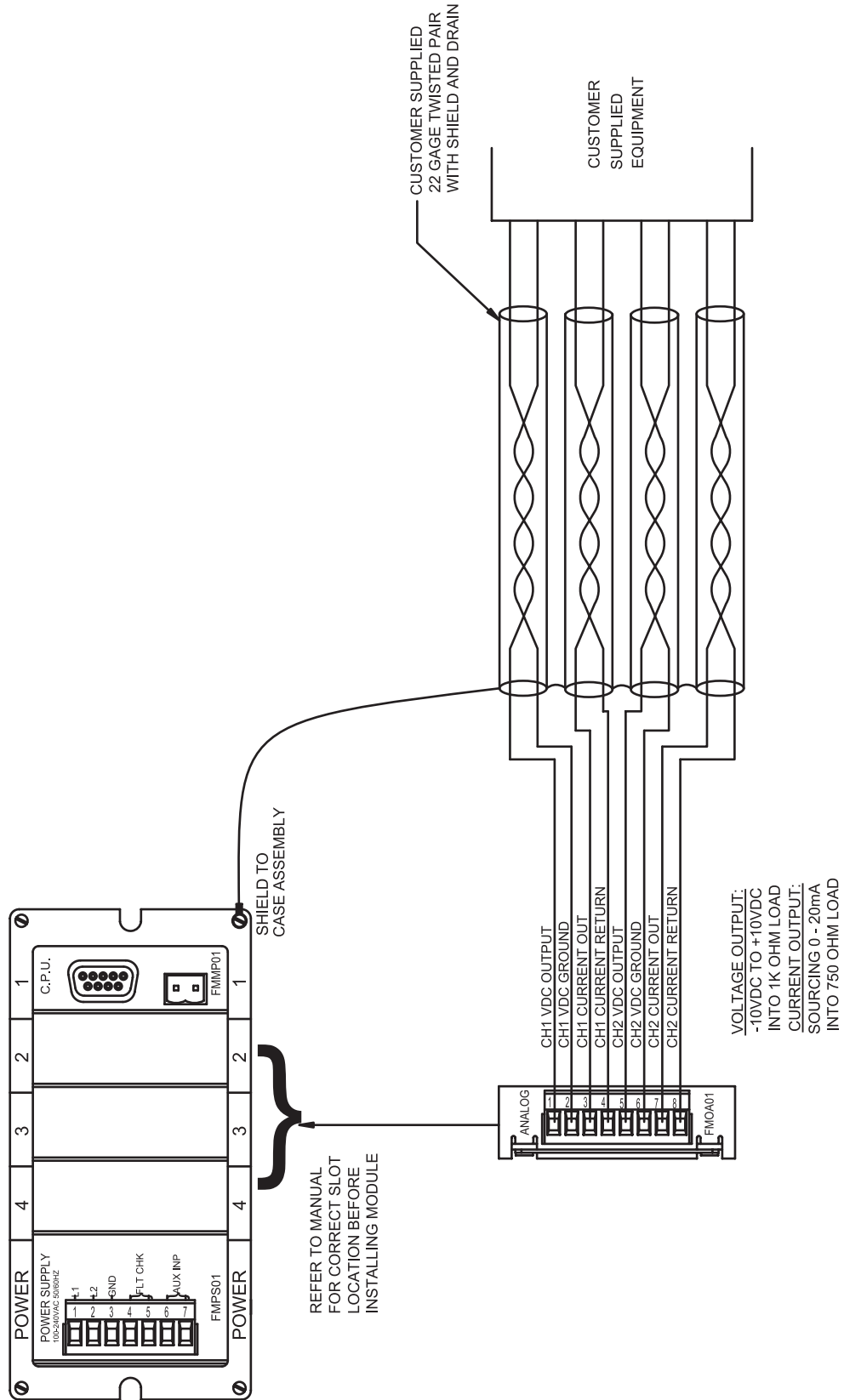

Fig 3-12 Wiring Diagram Analog Output
Drawing E8005090

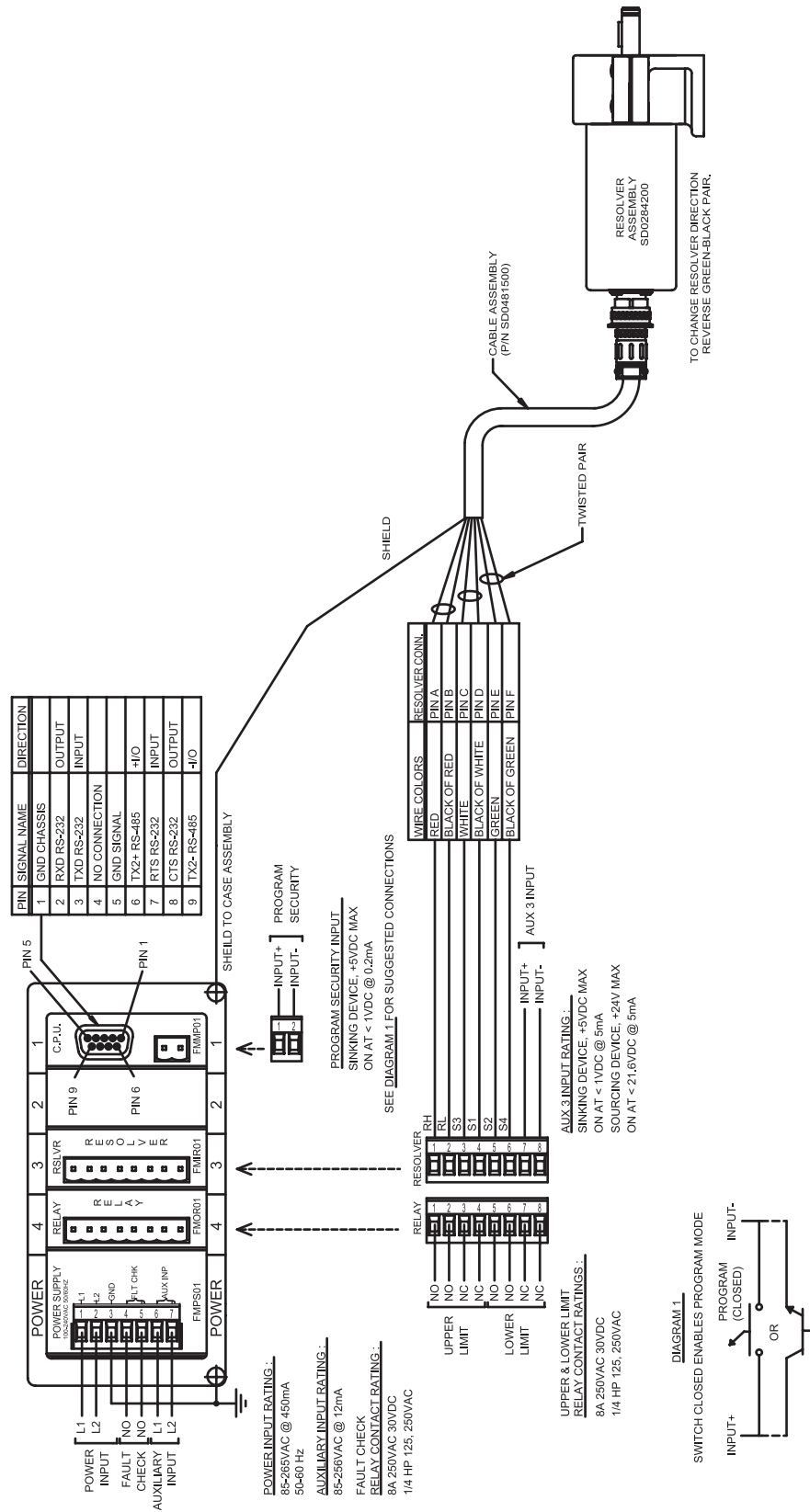

Fig 3-13 Resolver - Based System Wiring Diagram Drawing

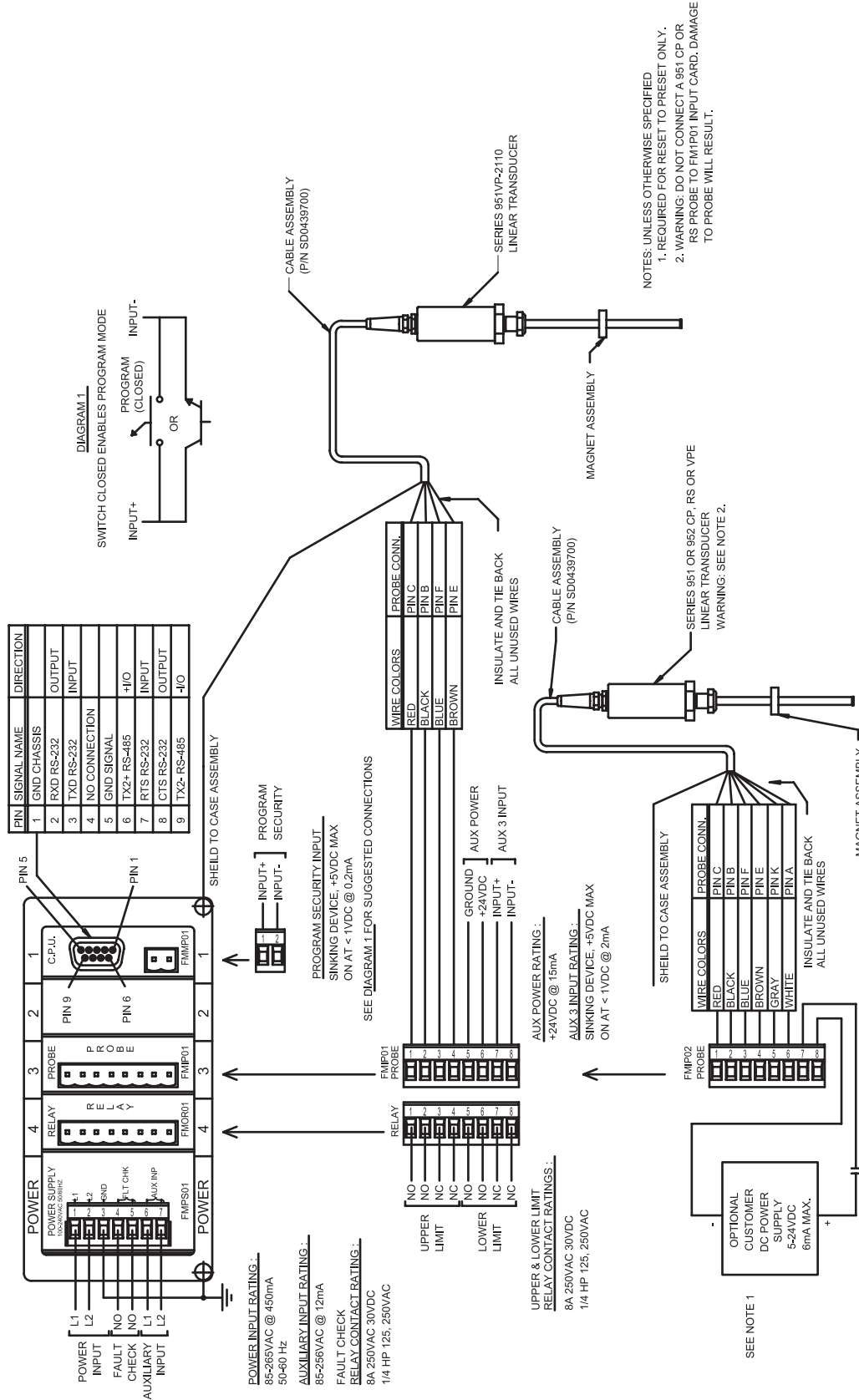

Fig 3-14 LDT - Based System Wiring Diagram
Drawing E0228700

NOTE 1: FOR FUTURE OPTION NOT REQUIRED ON THE 2110

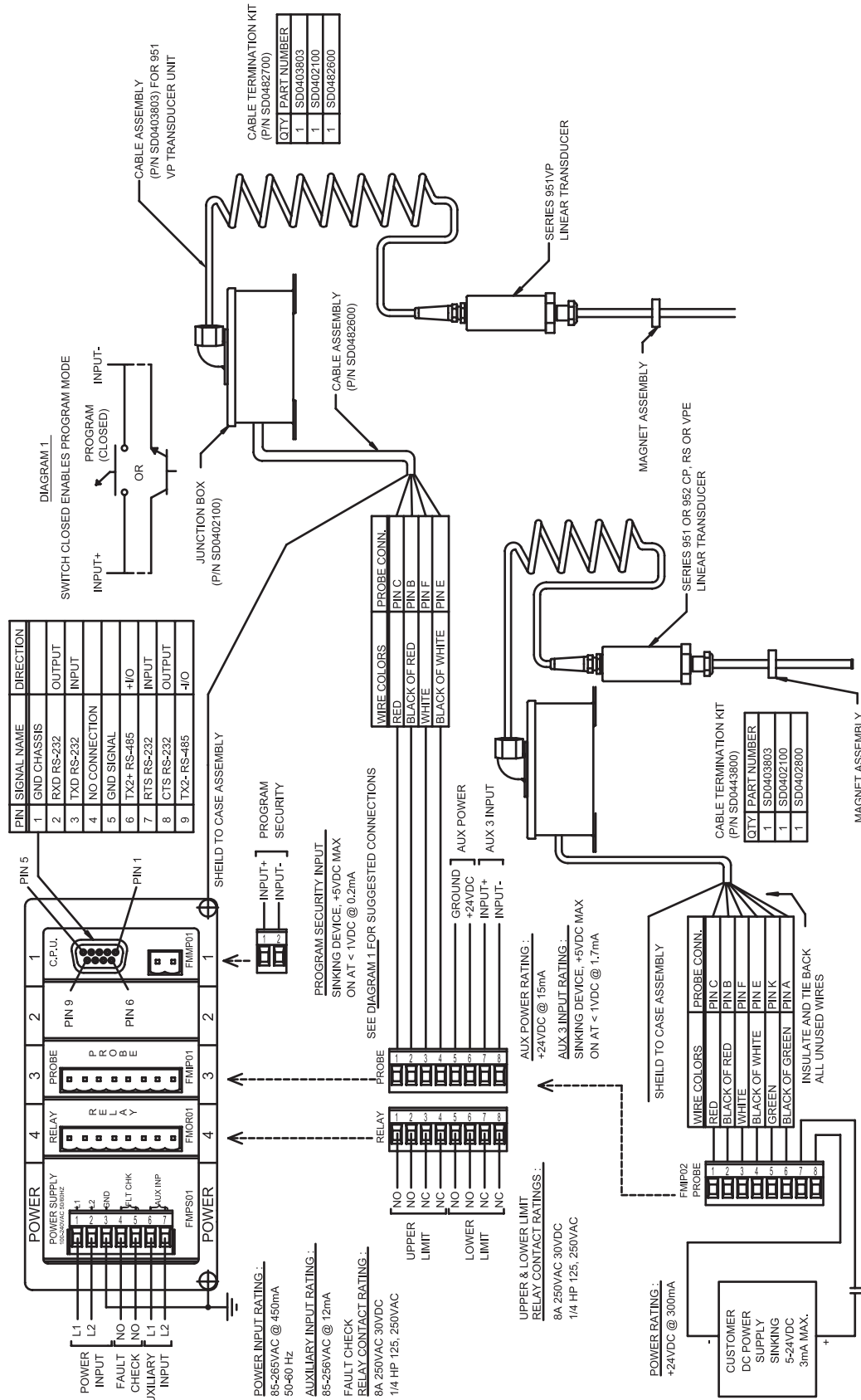

Fig 3-15 Wiring Monitor to Cable Termination Kit Drawing

Chapter 4: Programming

This chapter provides detailed descriptions and instructions for programming all shut height monitor's functions. A complete list of functions (with brief explanations) can be found in Appendix B: Function Summary Chart. This chapter divides the functions up into the following seven sections.

- 4.1 Resolver Configuration Functions
- 4.2 LDT Configuration Functions
- 4.3 Monitor Setup Functions
- 4.4 Press Setup Functions
- 4.5 Digital Outputs
- 4.6 Program and Supervisory Mode Functions
- 4.7 Analog Outputs

Resolver configuration functions are used to configure the resolver to the shut height monitor. (Refer to these functions only if you are using a resolver as an input device). LDT configuration functions are used to configure a Linear Displacement Transducer (LDT) to the shut height monitor. (Refer to these functions only if you are using an LDT as an input device.) Configuration functions should be programmed before any other functions. Monitor setup functions provide the means to customize the monitor's setup for a specific installation. Press setup functions provide the means to customize the press's setup for a specific installation. Program and supervisory mode functions are used to put the monitor in either program or supervisory mode, as well as program the length of programming time and change the program mode access code.

NOTE: Resolver or LDT configuration functions should be programmed first before any other type of programming is done. Refer only to your specific configuration section, depending on which input device you are using.

Before You Start

Before configuring or programming the shut height monitor, the following must be done in the following order:

- Jumper the monitor's program lockout connector (J2). To jumper this connector, see Section 3.2 Wiring.
- Put monitor in program mode. For instructions on putting the monitor in program mode, see Program Mode Access in Section 4.6: Program and Supervisory Mode Functions.

The program mode LED will turn on when the monitor is in program mode.

Figure 4-1 calls out the shut height monitor's programming keys. Following this figure are descriptions of these keys and how they work, as well as, a short tutorial on how to use the keys.

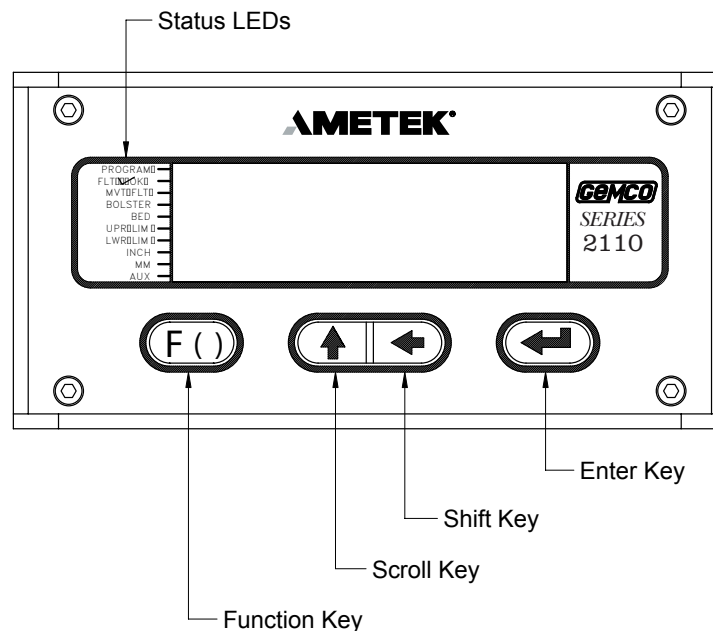

Figure 4-1 Programming Keys

Programming Keys Defined

The shut height monitor has four keys located on the front panel. These keys are used to program functions and perform basic operations.



The function key is used to begin a process for programming a function. When this key is pressed, the monitor prepares itself for the entry of a specific function number.



The scroll key is used to scroll through the monitor's list of function numbers, as well as other lists. To scroll to a particular function number, continue to select the scroll key (after selecting the function key) until the monitor displays the desired function number. The scroll key is also used to increment selected digits on the monitor's LED display. Incrementing digits can be done to either select a function number or a value for a function. To move to a specific digit on the display, use the shift key. A flashing digit indicates it is activated to be incremented. This key can also be used to get you quickly back to an incorrect parameter - rather than having to restart the function entry process. For example, if an invalid parameter was entered in the Upper End Limit function, you could select the scroll key. This would take the monitor back to displaying the current value, where you could re-enter a new value.



The shift key is used to move to a specific digit shown on the monitor's LED display. This can be done to either select a function number or a value for a function. To move to a specific digit on the display, select the function key and then the shift key. The right-most digit will then flash. This indicates that the digit is activated to be incremented. (To increment the digit, select the scroll key.) Continue to select the shift key until the desired digit is activated.



The enter key is used for several purposes. For example, it is selected after a function number is displayed. This begins the programming process for the selected function. The enter key is also used to program a value in a function. This is done by selecting the enter key after the desired value is displayed on the monitor's screen.

4.1: Resolver Configuration Functions

To customize the shut height monitor to your specific resolver and press installation, you must first make some configurations. These configurations are made through the use of resolver configuration functions, which are described in this section. Following the descriptions of these functions are instructions to configure your resolver. Perform these configuration procedures before entering other function values or attempting to use the monitor to indicate shut height.

- Scale Factor (300)
- Turns Counting (301)
- Position Offset (302)

NOTE: The unit of measurement is set in inches at the factory. If you want the unit of measurement to be set in millimeters, make this adjustment through the Unit of Measurement function before programming the Position Offset function. Instructions for programming the Unit of Measurement can be found in Section 4.3: Monitor Setup Functions.

Scale Factor (300)

The Scale Factor function is used to program the number of counts or the resolution that one revolution of the resolver results in. For example, when the function is programmed with a value of 100, the shut height monitor will count from 0 to 99 as the resolver completes a full revolution. The default value for this function is 4096. There is no maximum value that can be programmed for this function.

Turns Counting (301)

The Turns Counting function defines the number of revolutions the resolver must rotate before the scale factor is reached. For example, when this function is set at 2 and the scale factor is set at 100, the resolver will have to make two full revolutions before 100 counts is reached. The Turns Counting Function can be disabled by setting its value to 0. When disabled, the scale factor will cover its entire range in one revolution and roll over to 0 after one complete revolution. When the Turns Counting function is set to 1, the total count will increase by the scale factor for each revolution. For example, if the scale factor were set at 100 and turns counting at 1, after five revolutions, the monitor would display 500 counts. The default value for this function is 0.

Position Offset (302)

The Position Offset function is used to synchronize the resolver's position with the actual machine position. The default value for this function is 0. This function is used to adjust the shut height monitor's indicated position so that it truly reflects the press's shut height. There is no maximum value that can be programmed for this function.

Configure the Resolver

This subsection provides the necessary instructions to configure the shut height monitor to your resolver. Perform these steps before attempting to use the monitor to indicate shut height. Once these steps have been performed they will not have to be repeated.



1. Select the function key.

10

The monitor displays "F-----".



2. Enter function number 10. (This is the Program Mode Access function which allows you to put the monitor in program mode. Only when the monitor is in program mode can other functions be programmed.) Select the enter key.

The monitor displays "000000".

NOTE: If the shut height monitor displays only one zero (i.e. "0"), then the program lockout connector is not jumpered. For wiring instructions, see Section 3.2: Wiring.

Enter pro-
gram mode
access code



3. Enter either the program mode access code. The default code is 2100. Select the enter key.

The monitor is now in program mode. The program mode LED is turned on.

NOTE: The shut height monitor is defaulted to stay in program mode for 120 seconds. The monitor will drop out of program mode if a key is not pressed within this time. If this occurs, you will have to repeat steps 1-3. Further, the access code (2100) is provided initially. This code can be changed through the use of the New Access Code function. For security reasons, this function can only be implemented when the monitor is in supervisory mode. For more information on New Access Code, contact the factory.

Enter Scale Factor for the Configuration Process

NOTE: If you know the desired scale factor value, go to Step 17 on page 31.



300

4. Select the function key.

The monitor displays “F-----”.



Enter
001000

5. Select function number 300. (This is the Scale Factor function.) Select the enter key.

The monitor displays the function’s current value.



6. Enter 001000. (This value will change the scale factor to produce 1000 counts per resolver revolution.) Select the enter key.

Set Turns Counting to 1



301

7. Select the function key.

The monitor displays “F-----”.



Enter
000001

8. Select function number 301. (This is the Turns Counting function.) Select the enter key.

The monitor displays the function’s current value.



Follow
step 10

9. Enter 000001. (This value will cause the position to continue to increment after each revolution.) Select the enter key.

10. Using a dial indicator with a minimum of 1.000” of travel and a magnetic base, affix the indicator between the bolster plate and ram. Zero the dial indicator.

NOTE: The shut height monitor is defaulted to display position in inches. It can be changed to read position in millimeters, however. To make this change, see Unit of Measurement in Section 4.3: Monitor Setup Functions. Steps 11-13 will have to be repeated if the unit of measurement is changed.

Set the Position Offset to 0



11. Select the function key.

The monitor displays “F-----”.

302



12. Select function number 302. (This is the Position Offset function.) Select the enter key.

The monitor displays the function’s value.

Enter
000000



13. Enter 000000. (This value will set the indicated shut height position offset to 0 in comparison with the current position of the ram.) Select the enter key.

Follow steps
14-16

14. Move the slide adjust until the ram has moved 1.000” according to the dial indicator.

15. Divide 1.000 by the number the monitor is displaying. Include all digits (including the decimal point) in the calculation.

16. Multiply the result of step 15 by 1000.

Enter Newly Determined Scale Factor



17. Select the function key.

The monitor displays “F-----”.

300



18. Select function number 300 (Scale Factor function). Select the enter key.

The monitor displays “001000”.

Enter sum
of step 16



19. Enter the result of step 16, including digits up to a maximum of three spaces to the right of the decimal point. Select the enter key.

Adjust the Turns Counting Factor



20. Select the function key.

The monitor displays “F-----”.

301

21. Select function number 301 (Turns Counting function). Select the enter key.



Enter
001000

The monitor displays “001000”.

22. Enter 001000. Select the enter key.



23. Select the function key.

The monitor displays “F-----”.



24. Select function number 302 (Position Offset function). Select the enter key.

302

The monitor displays the current position of the shut height.



25. Enter the actual position of the shut height as measured from the bed to the ram. It is recommended that a set of inside micrometers be used to acquire this information.

Enter
000000

To verify that you have accurately calibrated the resolver, move the slide adjust 1.000”. After this has been done, the new position indicated should also have moved 1.000”.



After configuring the resolver to the shut height monitor, you can proceed to Section 4.3: Monitor Setup functions.

4.2: LDT Configuration Functions

There are two input cards available for use with LDTs.

1. Specified as option V1 in the part number and is labeled (FMIP01) on the card.
2. Specified as option L1 in the part number and is labeled (FMIP02) on the card.

The configuration of the module and this LDT is different depending on which module you have ordered. Determine which module you have and proceed to the section below for programming instructions.

Option V1 - This module can only be used with Gemco LDTs with a part number starting with 951VP1992 or 951VP2110.

Wire speed and recirculations for these LDTs have been configured at the factory for maximum resolution.

NOTE: Always refer to the LDT legend plate for programming wire speed (Function 300). The wire speed will always be between 500.000 and 600.000 micro sec./inch.

Option L1 - This module is designed to be used with any LDT with digital output. These include Series 951, 952 with VP, RS or CP outputs.

This module provides faster updates of position while using the LDT with standard wire speeds.

NOTE: Review the LDT legend plate for correct wire speed. Wire speed will always be between 8.000 and 10.000 micro sec./inch.

NOTE: If option L1 is used, the first step in configuration must be Function 307 (LDT Type) that tells the module which LDT is being used.

NOTE: Before an LDT configuration function can be programmed, the shut height monitor must be in program mode. To put the monitor in program mode, see Program Mode Access in Section 4.6: Program and Supervisory Mode Functions.

Wire Speed (300)

Programming of the wire speed synchronizes the performance of the module with the performance of the LDT. You will find the wire speed on the legend plate of your LDT.

To program wire speed, perform the following steps:



300



Enter new value



1. Select the function key.
The monitor displays “F-----”.
2. Select function number 300 . Select the enter key.
The monitor displays the function’s current value.
3. Enter the new wire speed value. Select the enter key. Count Direction (301)

Count Direction (301)

The Count Direction function is used to change the direction the shut height position will move as the LDT's magnet travels along the guide rail. A 0 value will cause the position to increment as the magnet moves away from the LDT head. A value of 1 will cause the position to increment as the magnet moves toward the LDT head. The default for this function is 1. For further explanations, see Figure 4-2. To change the value of the Count Direction function, perform the following steps:



1. Select the function key.

301

The monitor displays "F-----".



2. Select function number 301 . Select the enter key.

Enter either 0 or 1

The monitor displays the function's current value.



3. Enter either a 0 or 1. Select the enter key.

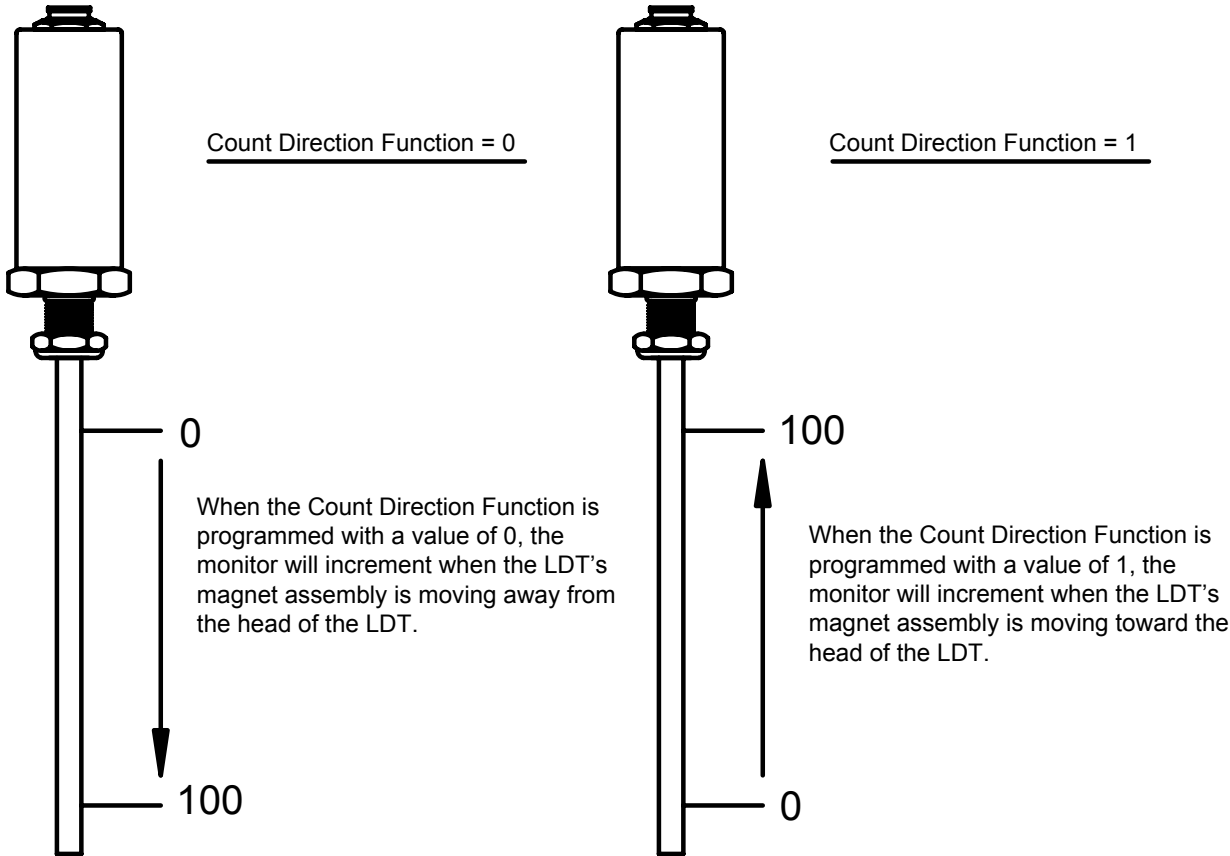

Figure 4-2 Count Direction Function

Position Offset (302)

NOTE: Make sure the unit of measurement function is selected to your desired units before entering the value for the Position Offset function. The unit of measurement is set in inches at the factory. For instructions on selecting the unit of measurement, see Unit of Measurement in Section 4.3: Monitor Setup Functions.

The Position Offset function is used to synchronize the monitors displayed value with actual shut height. This value can range from -99.999 to 999.999 inches. With the LDT installed on the press and functioning properly, physically measure the shut height. Enter the measured value in this function. To change the value of the Position Offset function, perform the following steps:



1. Select the function key.

302

The monitor displays “F-----”.



2. Select function number 302 . Select the enter key.

Enter current
Shut Height
Position

The monitor displays the current shut height position.

3. Enter the new position offset value. Select the enter key.



Zero Pulse Time (305)

The Zero Pulse Time function is used to enter the pulse time that the monitor will recognize as the absolute zero position on the LDT. The default for this function is 1.000 millisecond. This value matches the Zero Pulse Time of the 951VP-1992 and should not require an adjustment. The zero pulse time value can range from 1.000 to 99.999 milliseconds. To change the value of the Zero Pulse Time function, perform the following steps:



1. Select the function key.

305

The monitor displays “F-----”.



2. Select function number 305 . Select the enter key.

Enter new
zero pulse
time

The monitor displays the function’s current value.

3. Enter the new zero pulse time. Select the enter key.



Fault Pulse Time (306)

The Fault Pulse Time function is used to program the pulse time of the fault signal sent by the LDT when it detects an error. When the monitor receives a fault signal of this pulse time, it will indicate an error (see Appendix A: Error Messages). The default for this function is 10 microseconds. This value can range from 1 to 99 microseconds. A 0 is entered in this function to disable it. To change the value of the fault pulse time or disable this function, perform the following steps:

NOTE: Do not change the value unless using an LDT other than Gemco.



1. Select the function key.

The monitor displays “F-----”.

306



2. Select function number 306 . Select the enter key.

The monitor displays the function’s current value.



3. Enter a 0 to disable this function or enter a new fault pulse time. Select the enter key.

After configuring the LDT to the shut height monitor, you can proceed to Section 4.3: Monitor Setup Functions.

LDT Output Type (307)

This function is used to configure the L1 input board for use with a specific LDT output. Review legend plate of the LDT for output type, i.e. CP, RS or VP. Perform the following steps:



1. Select the function key.

The monitor displays “F-----”.

307



2. Select function number 307 . Select the enter key.

Enter either:

0 = CP

1 = RS

2 = VP (external interrogation) (See Note below)

3 = VP (internal interrogation)*

Enter New
Value

NOTE: The Variable Pulse with external interrogation mode is not compatible with the 952 probe. When using a 952 probe, select a different mode of operation.



3. Enter a 0 to disable this function or enter a new output type. Select the enter key.

*If used, program Function 308. Consult the factory for settings.

4.3: Monitor Setup Functions

This section provides descriptions and instructions for the shut height monitor setup functions. These functions provide the means to customize the monitor's setup for a specific installation. Before any of these functions can be programmed, the monitor must be in program mode. To put the monitor in program mode, see Program Mode Access in Section 4.6: Program and Supervisory Mode Functions. The following is a list of the monitor setup functions:

- Unit of Measurement (14)
- Decimal Location (13)
- Position Hold (15)
- Auxiliary LED (16)

Unit of Measurement (14)

The Unit of Measurement function is used to select the unit of measurement for the shut height and all position data. Measurements can be either in inches or millimeters. Enter a 0 to select inches or enter a 1 to select millimeters. The default for this function is 0. To change the unit of measurement, perform the following steps:



14

1. Select the function key.

The monitor displays "F-----"



2. Enter function number 14. Select the enter key.

Enter either 0
or 1

The monitor displays the function's current value.



3. Enter either 0 or 1. Select the enter key.

NOTE: If you change the unit of measurement, the decimal location shown on the monitor's LED display will change to the default position for the unit of measurement selected. If you select millimeters, position data will be displayed in hundredths; selecting inches will display data in thousandths. For more information, see Decimal Location.

NOTE: The Unit of Measurement should be programmed prior to the scale factor on systems using a resolver input.

Decimal Location (13)

The Decimal Location function is used to program the resolution of the shut height and all position data shown on the monitor's LED display. Resolution can be either displayed in whole units, tenths, hundredths, or thousandths. Resolution choices correspond to the following values: 0 = whole unit; 1 = tenths; 2 = hundredths; and 3 = thousandths. To change the resolution shown on the monitor's LED display, perform the following steps:



1. Select the function key.

13

The monitor displays "F-----"



2. Select function number 13. Select the enter key.

Enter either
0, 1, 2, or 3

The monitor displays the function's current value.



3. Enter either a 0, 1, 2, or 3. Select the enter key.

Position Hold (15)

The Position Hold function stops the monitor from displaying irrelevant fluctuations during a press's stamping cycle. When the monitor's auxiliary input is activated, this function will hold the last position read. Either a 0, 1, or 2 can be programmed in this function. Entering a 1 will cause the monitor to hold the last position read when power is applied to the auxiliary input. Entering a 2 will cause the monitor to hold the last position read when power is taken away from the auxiliary input. Entering a 0 disables this function. The default for this function is 0. Enabling this function disables the Move Detection Time-Out function. When the Position Hold function is enabled, the value for the Move Detection Time-Out is then used for the Position Hold dwell time. The position hold dwell time is the amount of time the monitor continues to hold the shut height position after the auxiliary input is released (or activated, depending on the input's programmed state). To enable or disable the Position Hold function, perform the following steps:



1. Select the function key.

15

The monitor displays "F-----"



2. Enter function number 15. Select the enter key.

Enter either
0, 1, or 2

The monitor displays the function's current value.



3. Enter either 0, 1, or 2. Select the enter key.

NOTE: The default time for the position hold dwell may be too long for your application. To change this value for your application, perform the following steps.



12

4. The default value for the Move Detection Time-Out function is 5.00 seconds. To change this value for the position hold dwell time, select the function key.

The monitor displays “F-----”



Enter new
dwell value

5. Enter function number 12. Select the enter key.

The monitor displays the current value for the position hold dwell time. This value is in seconds.



6. Select the new dwell time. Select the enter key.

NOTE: The Position Hold function only holds the position on the monitor’s LED display. Internally, the shut height position and the upper and lower limit relays are continually being updated. In addition, the auxiliary LED can be used to determine when a position hold occurs. However, this LED must be selected for this feature. To enable this LED, see Auxiliary LED.

Auxiliary LED (16)

The Auxiliary LED function is used to enable the monitor’s auxiliary LED. This LED is currently used only to indicate a position hold. (For more information, see Position Hold). Either a 0 or 1 can be programmed in this function. Entering a 0 will disable the LED. Entering a 1 will enable the LED to turn on when a position hold occurs. The default for this function is 0. To enable or disable the auxiliary LED, perform the following steps:



16

1. Select the function key.

The monitor displays “F-----”



Enter either 0
or 1

2. Select function number 16. Select the enter key.

The monitor displays the function’s current value.



3. Enter either 0 or 1. Select the enter key.

4.4: Press Setup Functions

This section provides descriptions and instructions for press setup functions. These functions provide the means to customize the press's setup for a specific installation. Before these functions can be programmed, the monitor must be in program mode. To put the monitor in program mode, see Program Mode Access in Section 4.6: Program and Supervisory Mode Functions. The following is a list of the press setup functions:

- Move Detection Time-Out (12)
- Bolster Offset (303)
- Negative Over Travel Limit (304)
- Upper End Limit (400)
- Lower End Limit (401)
- Relay State (402)
- Relay Override (403)

Move Detection Time-out (12)

The Move Detection Time-out function is used to program the time the press's shut height must move within when power is applied to the ram adjust motor(s). The default value for this function is 5.00 seconds. This value can range from 0 to 99.99 seconds. Entering a 0 disables this function. The purpose of this function is to detect a possible jam or drive component failure. When power is applied to the press's ram adjust motor(s), the monitor's auxiliary input receives an AC voltage. When this occurs, the monitor begins to look for shut height movement. If movement is not detected within the programmed time, the upper and lower limit relays will de-energize and the fault check relay will open. Also, the movement fault LED will turn on and the monitor will display an error message (see Appendix A: Error Messages). This error will have to be cleared before machine operation can resume. To change the move detection time-out value or disable the function, perform the following steps:

(F)

1. Select the function key.

12

The monitor displays "F-----"



2. Enter function number 12. Select the enter key.

Enter new
time-out
value

The monitor displays the function's current value.





3. Enter the new time-out value. Select the enter key.

NOTE: The power supply's auxiliary input must be wired properly in order for the Move Detection Time-Out function to work. For instructions on wiring the auxiliary input, see Section 3.2: Wiring.



Bolster Offset (303)

The Bolster Offset function is used to program the thickness of a bolster plate installed on the bed of the press. The value programmed in this function is internally subtracted from the programmed shut height. This function's value cannot exceed the maximum scaled position. The default for this function is 0.000 inches. This value can range from 0.000 to 999.999 inches. When this function contains a value of 0, the monitor's bolster LED will turn off, indicating no bolster plate is installed. Only when this function contains a value other than 0 will this LED turn on. To program a value in the bolster offset function, perform the following steps:

-  1. Select the function key.
The monitor displays "F-----"
- 303**
 2. Select function number 303. Select the enter key.
The monitor displays the function's current value.
- Enter bolster offset
 3. Enter the new bolster offset value. (This is the thickness of the bolster plate.)
Select the enter key.

Negative Over Travel Limit (304)

The Negative Over Travel Limit function is used to program the maximum allowable distance the shut height can travel below zero before the monitor will give an error. If the shut height moves beyond this position, the upper and lower limit relays will de-energize and the fault check relay will open. The monitor will also display an error (see Appendix A: Error Messages). This error must be cleared before machine operation can resume. The default for this function is 0.050 inches. This value can range from 0 to 999.999 inches. The value entered in this function is a positive number, however, the limit is negative because it is below zero. Typical shut height readings may never approach zero. However, for installations that do, this function limits the height adjustment when it goes below zero. To change the value of the Negative Over Travel Limit function, perform the following steps:

-  1. Select the function key.
The monitor displays "F-----"
- 304**
 2. Select function number 304. Select the enter key.
The monitor displays the function's current value.

Enter new
setting

3. Enter the new value. Select the enter key.



4.4: Relay Setup Functions - Option K1

If your system includes the optional relay module (K1), the following function numbers are used for setup. Before these functions can be programmed, the monitor must be in program mode. To put the monitor in program mode, see Program Mode Access in Section 4.7: Program and Supervisory Mode Functions. The following is a list of the press setup functions.

- Upper End Limit (400)
- Lower End Limit (401)
- Relay State (402)
- Relay Override (403)

Upper End Limit (400)

The Upper End Limit function is used to program the upper limit of the shut height opening. This can prevent the ram from accidentally exceeding its mechanical adjustment capabilities. If the shut height reaches or exceeds the value programmed in this function, the upper limit relay will de-energize and the upper limit LED will turn on. This can cause power to be taken away from the press's ram adjust motor(s) if the upper limit relay is properly wired. (For wiring instructions, see Section 3.2: Wiring.) The default for this function is 999.999 inches. This value can range from 0 to 999.999 inches. To program a value for the Upper End Limit function, perform the following steps:



1. Select the function key.

400

The monitor displays "F-----"



2. Enter function number 400. Select the enter key.

Enter upper
limit

The monitor displays the function's current value.



3. Enter the new value. Select the enter key.

NOTE: To temporarily regain lost power to the ram adjust motor(s) (close the upper end limit relay) if the shut height reaches or exceeds the upper end limit, see Relay Override.

Lower End Limit (401)

The Lower End Limit function is used to program the lower end limit of the shut height opening. This can prevent the ram from accidentally exceeding its mechanical adjustment capabilities. If the shut height reaches or goes below the value programmed in this function, the lower limit relay will de-energize and the lower limit LED will turn on. This can cause power to be taken away from the press's ram adjust motor(s) if the lower limit relay is properly wired. (For wiring instructions, see Section 3.2: Wiring.) The default for this function is 0.000 inches. This value can range from 0 to 999.999 inches. To program a value for the Lower End Limit function, perform the following steps:



1. Select the function key.

401

The monitor displays "F-----"



Enter lower
end limit

2. Enter function number 401. Select the enter key.

The monitor displays the function's current value.



3. Enter the new value. Select the enter key.

NOTE: To temporarily regain lost power to the ram adjust motor(s) (close the lower end limit relay) if the shut height reaches or goes below the lower end limit, see Relay Override.

Relay State (402)

The Relay State function is used to program the monitor's upper and lower limit relays to either energize or de-energize when the monitor is in normal machine operation. Either a 0 or 1 can be programmed in this function. Entering a 0 will cause the monitor to energize the relays during machine operation, and de-energize the relays when a limit is exceeded or when an error occurs. Entering a 1 will cause the monitor to de-energize the relays during machine operation, and energize the relays when a limit is exceeded or when an error occurs. The default for this function is 0. To change the state of these relays, perform the following steps:



1. Select the function key.

402

The monitor displays "F-----"



Enter either
0 or 1

2. Enter function number 402. Select the enter key.



The monitor displays the function's current value.



3. Enter either a 0 or 1. Select the enter key.

Relay Override (403)

The Relay Override function is used to temporarily allow the press operator to readjust the shut height once it has exceeded a programmed end limit. If the upper or lower limit relays are wired into the power interlock system, power may be lost when the shut height goes beyond the values programmed in the upper or lower limit functions. (For more information, see Upper End Limit and Lower End Limit.) To override either the upper or lower limit relays, perform the following steps:

- | | |
|---|---|
| 
403 | <ol style="list-style-type: none"> 1. Select the function key. <p style="margin-left: 20px;">The monitor displays “F-----”</p> |
| 
Enter 2110 | <ol style="list-style-type: none"> 2. Enter function number 403. Select the enter key. <p style="margin-left: 20px;">The monitor displays “000000”</p> |
|  | <ol style="list-style-type: none"> 3. Enter the override code 2110. Select the enter key. |



NOTE: After re-energizing either the upper or lower limit relays, the operator should move the shut height back into its range between its upper and lower limits. If the shut height is again moved in the wrong direction (towards the limits), the upper or lower limit relays will again de-energize, if the relays were programmed to do so. Step 1 - 3 will have to then be repeated.

4.5: Digital Outputs

If your system has been purchased with the optional digital output module, the following programming sequence will be used to configure the board for compatibility with the PLC input card.

Output Type (200)

This function will set up the D25 connector on the digital board to output the current position value in a Binary, BCD or Grey code format:

- | | |
|--|--|
| 
200 | <ol style="list-style-type: none"> 1. Select the function key. <p style="margin-left: 20px;">The monitor displays “F-----”</p> |
| 
Enter either
0, 1 or 2 | <ol style="list-style-type: none"> 2. Enter function 200. Select the enter key. <p style="margin-left: 20px;">The monitor displays the function’s current value.</p> |
|  | <ol style="list-style-type: none"> 3. Enter either 0, 1 or 2.
 0 = Binary (default)
 1 = BCD
 2 = Grey
 Select the enter key. |

Latch/Synchronize Handshake (201)

The function defines which of the two methods will be used to stabilize position data while the PLC reads. The two options are Latch or Synchronize Handshake. Synchronize Handshake tells the digital board to update on the transitional edge of a clocked square wave input (pin 24). Latch tells the digital board to update continuously until the latch input pin is activated by driving high, then the outputs will freeze.

NOTE: If set for Synchronize handshake, the position data will never update if a square wave input is not seen on pin 24.



1. Select the function key.

201

The monitor displays “F-----”



2. Enter function 201. Select the enter key.

Enter either
0 or 1

The monitor displays the function’s current value.



3. Enter either 0 or 1.
0 = Latch (default)
1 = Synchronize

Select the enter key.

Logic Level (202)

This function will set up selection of either high true or low true.



1. Select the function key.

202

The monitor displays “F-----”



2. Enter function 202. Select the enter key.

Enter either
0 or 1

The monitor displays the function’s current value.



3. Enter either 0 or 1.
0 = Low True
1 = High True (default)

Select the enter key.

Error Condition Output State (203)

This function allows you to select how the digital outputs will react to a failure in the encoder module, transducer and/or cable. The following three options describe what will happen on a failure.



1. Select the function key.

The monitor displays “F-----”

203



2. Enter function 203. Select the enter key.

The monitor displays the function’s current value.

0, 1 or 2
Enter either



3. Enter either 0, 1 or 2.
0 = All Outputs Off (default)
1 = All Outputs On
2 = Last Valid Position

Select the enter key.

4.6: Analog Outputs

The Analog Output board provides two channels of analog output that can be independently configured and scaled. Each channel can be configured for an output based upon position.

Each of the two analog output channels generate a simultaneous voltage and current output. You can use either the current or voltage output on one channel but not both.

The following programming sequences require that you specify your intent to use either the voltage or current output for each channel prior to programming the output scaling. You can configure one analog channel for use of its voltage output and configure the other channel for current.

The analog output board will be factory installed in slot 2 or slot 4 of the Series 2110 module's chassis. Look at the back of your Series 2110 module and verify which slot your analog output board has been installed in. The following programming function numbers are shown with an "X" as the first digit. The "X" must be replaced with the number 2 or 4 which corresponds to the slot in which your analog output board was installed at the factory.

NOTE: Boards cannot be changed from their factory supplied slot location in the field.

It is recommended that you configure and program the analog output in the following sequence. Perform all programming steps for one output channel before proceeding to the other output channel.

REPLACE "X" WITH SLOT LOCATION

Analog Output Channel 1

A) Select voltage or current output



1. Select the function key.

The monitor displays "F-----"

X04



2. Enter function number X04. Select the enter key.

The monitor displays the current function value.

Enter
0 or 1

0 = voltage output

1 = current output



3. Leave current value or change. Select enter key.

C) Scaling Analog Output

The analog output is scaled by programming a minimum position value followed by the analog output value required at that position. A maximum position value is then programmed followed by the analog output required at that position.

The analog output value specified can be any value within the following allowable range:

Voltage	-10 VDC to 10 VDC
Current	0mA to 20mA

The analog output will stop changing upon reaching the minimum and maximum values programmed. This allows selection of a nonstandard output like 2 to 8 VDC or 10 to 20 mA.

The position range over which the analog output develops can be any portion of the total change seen by the Interface Module.

Example: Program analog output channel 1 for 2 to 8 VDC over 500 to 2000 count change.

1. Select Voltage output as described earlier under step A
2. Select function key.

(F)

The monitor displays “F----”.

X02

3. Enter function number X02. Select enter key.

↵

The monitor displays current minimum position value.

Enter
000500

4. Enter 500. Select enter key. This sets minimum position value at 500 counts. The monitor displays 000500.

↵

5. Select function key.

(F)

The monitor displays “F----”.

X05

6. Enter function number X05. Select enter key.

↵

The monitor displays current voltage output value linked to minimum position value.

Enter
002000

7. Enter 2. Select enter key. This sets a minimum voltage output value of 2VDC for 500 counts or less.

↵

The monitor displays 002000.



8. Select function key.

X03

9. Enter function number X03. Select enter key.



The monitor displays current maximum positions value.

Enter
002000

10. Enter 2000. Select enter key. This sets maximum position value at 2000 counts.



The monitor displays 002000.



11. Select Function key.

The monitor displays “F-----”.

X06

12. Enter function number X06. Select enter key.



The monitor displays current voltage output value linked to maximum count value.

Enter
008000

14. Enter 8. Select enter key. This sets a maximum voltage output value of 8VDC at 2000 counts or more.



The monitor displays 008000.

Analog output channel 1 will now provide a 2 to 8 VDC output as position increases between 500 and 2000 counts. Position values below 500 will result in a 2 VDC analog output. Position values above 2000 will result in an 8 VDC output.

Analog output channel 2 is programmed using the same basic sequences except with the function numbers noted below. Remember that the X shown in the function number represents the slot in which the analog output board is installed in the Interface Module chassis.

Analog Output Channel 2 - Function numbers

A) Select voltage or current output

Function No. X10

B) Scaling analog output

- Select minimum position

Function No. X08

- Select analog output value to be linked to minimum position value

Function No. X11

- Select maximum position value
Function No. X09

- Select analog output value to be linked to maximum position value
Function No. X12

4.7: Program and Supervisory Mode Functions

This section provides descriptions and instructions for program and supervisory mode functions. These functions are used to put the shut height monitor in either program or supervisory mode, as well as program the length of programming time and change the program mode access code. Before a function can be programmed, the monitor must be in program mode. This is done through the Program Mode Access function, which is the first function described in this section. The monitor can also be put in supervisory mode. Putting the monitor in this mode allows supervisory functions. Instructions for putting the monitor in this mode are also described in Program Mode Access. The following is a list of the program and supervisory mode functions:

- Program Mode Access (10)
- Program Mode Time-Out (11)
- New Access Code (90)

NOTE: The controller's program lockout connector (J2) must be jumpered to allow the unit to enter program mode. For wiring instructions, see Section 3.2: Wiring.

Program Mode Access (10)

The Program Mode Access function is used to put the shut height monitor in either program or supervisory mode. Only when the monitor is in program mode can other functions be programmed. The monitor is defaulted to stay in program mode for 120 seconds (see Program Mode Time-Out). The monitor will drop out of program mode if a key is not pressed within this time. A program mode access code must be entered in this function in order to put the monitor in program mode. The monitor can also be put in supervisory mode. Only when the monitor is in supervisory mode can supervisory functions be programmed. A supervisory mode access code must be entered in order to put the monitor in supervisory mode. For security reasons, this code was not sent with this manual. Contact AMETEK to receive this code. To place the monitor in either program or supervisory mode, perform the following steps:

1. Select the function key.

The monitor displays "F-----"

2. Enter function number 10. Select the enter key.

The monitor displays "000000"

NOTE: If the shut height monitor displays only one zero (i.e. “0”), then the program lockout connector is not jumpered. For wiring instructions, see Section 3.2: Wiring.

Enter access code

3. Enter either the program or supervisory mode access code. The default program mode access code is 2100. Select the enter key.



The monitor is now in either program mode or supervisory mode. The program mode LED is turned on.

NOTE: The shut height monitor can be taken out of program or supervisory mode at any time by entering an invalid access code in the Program Mode Access function. Further, the access code (2100) is provided initially. However, this code can be changed through the use of the New Access Code function. For security reasons, this function can only be implemented when the monitor is in supervisory mode. For more information on New Access Code, contact the factory.

Program Mode Time-Out (11)

The Program Mode Time-out function is used to change the duration of time the monitor will stay in program mode once the Program Mode Access function is entered (see Program Mode Access). If a key is not pressed within the time programmed in this function, the monitor will drop out of program mode. Every time a key is pressed, the timer will restart. The default for this function is 120 seconds. This value can range from 10 to 1000 seconds. To change the program mode time-out value, perform the following steps:



1. Select the function key.

11

The monitor displays “F-----”



2. Select function number 11. Select the enter key.

Enter new time-out value

The monitor displays the function’s current value.



3. Enter the new time-out value. Select the enter key.

NOTE: The Program Mode Time-Out function serves two purposes. The first is that when the monitor is in program mode and a key is not pressed within the time-out delay, this function will take the monitor out of program mode. The second purpose is that when the monitor is displaying something other than the shut height, and is or is not in program mode, and a key is not pressed within the time-out delay, this function will force the monitor to display the current shut height position.

Appendix A: Error Messages

The shut height monitor displays an error message when an error occurs during machine operation. The format for errors appearing on the monitor's LED display is illustrated in Figure A-1. Descriptions and solutions for errors are provided in charts A-1 through A-3. Error messages are grouped into the following three categories:

System Error	This type of error is caused by one of the monitor's modules or input device. It typically indicates some form of a hardware failure or problem with the input device. For example, if the input device is disconnected from the input module, the monitor will display a system error.
Operating Error	This type of error is caused by problems with typical machine operation. For example, if the press's shut height does not move within the time programmed in the Move Detection Time-Out function, the monitor will display an operating error.
Entry Error	This type of error is caused by an invalid entry through the use of the monitor's keypad. For example, if an invalid function number is entered or a value for a function that is out of range is entered, the monitor will display an entry error.

NOTE: To clear errors, perform the solutions found in charts A-1, A-2, and A-3. After completing the solution, press the enter key.

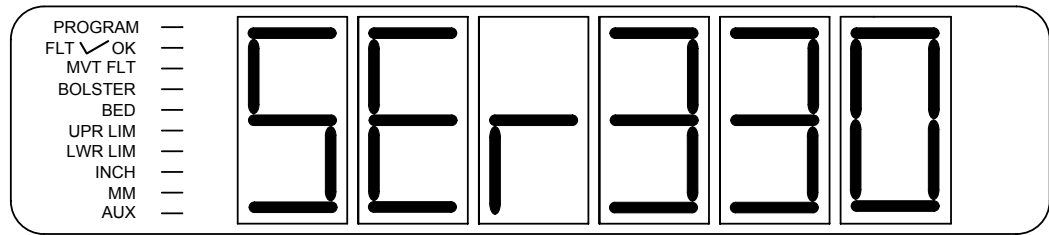

Describes the Type of Error

SEr = System Error

OEr = Operating Error

EEr = Entry Error

Indicates Slot that Relates to Error*

1 = Slot 1

2 = Slot 2

3 = Slot 3

4 = Slot 4

Indicates Module that Relates to Error *

0 = Controller

6 =

1 =

7 =

2 = Resolver

8 =

3 = LDT (VP)

9 =

4 = LDT (CP)

A =

5 = Relay Output

B =

Indicates Error

(refer to error chart for descriptions and solutions to errors)

* For entry errors, the three right-most digits represent the particular entry error number. See Chart A-3.

Figure A-1: Characteristics of an Error Message

The following charts contain descriptions and solutions for the three types of errors that can appear on the monitor's LED display. To clear errors, perform the solutions found in charts A-1, A-2, and A-3, followed by pressing either the scroll, shift, or enter.

Error Displayed	Error Description	Solution
SER101	A configuration error has occurred.	Contact GEMCO Tech. Support.
SER102	The monitor's function parameter memory has been corrupted.	Contact GEMCO Tech. Support.
SER103	The battery for the monitor's memory is low.	Contact GEMCO Tech. Support.
SER104	A software fault has occurred.	Contact GEMCO Tech. Support.
SER105	An error has occurred with the monitor's internal memory locations.	Clear the error and contact GEMCO Tech. Support.
SER106	A firmware CRC error has occurred.	Contact GEMCO Tech. Support.
SER320	This is a resolver-specific error. See Chart A-6.	
SER330	The input device is not connected to the monitor's input module.	Connect the input device to the input module and clear the error.
SER331	This is an LDT-specific error. See Chart A-7.	

Chart A-1 System Errors

Error Displayed	Error Description	Solution
OER101	The press's ram did not move within the time programmed in the Move Detection Time-Out function.	Review press operation and/or increase the value of the Move Detection Time-Out function.
OER330 or OER320	The press's shut height moved beyond the value programmed in the Negative Over Travel Limit Function.	Review press operation and/or increase the value of the negative Over Travel Limit function.

Chart A-2 Operating Errors

Error Displayed	Error Description	Solution
EEr 1	An invalid function number was entered.	Enter a valid function number.
EEr 2	An invalid system configuration was entered.	Enter a valid system configuration.
EEr 3	A value outside the function's acceptable range was entered.	Review function's range and re-enter value.
EEr 4	An incorrect parameter was entered.	Contact GEMCO Tech. Support.
EEr 5	A value was programmed into the Lower End Limit function that is greater than the value programmed in the Upper End Limit function.	Program a value that is less than the value programmed in the Upper End Limit function.
EEr 6	The value programmed into the Upper End Limit function is less than the value programmed in the Lower End Limit function.	Program a value that is greater than the value programmed in the Lower End Limit function.

Chart A-3: Entry Errors

The following chart contains errors that will cause the fault check relay to open:

Error Displayed	Error Description
SER101	A configuration error occurred.
SER106	Firmware CRC error occurred.
SER320	This is resolver-specific error. See Chart A-6.
SER330	The input device is not connected to the monitor's input module.
SER331	This is an LDT-Specific Error. See Chart A-7.
OEr101	The press's ram did not move within the time programmed in the Move Detection Time-out function.
OEr330 or OEr320	The press's shut height moved beyond the value programmed in the Negative Over Travel Limit function.

Chart A-4 Fault Check Relay Errors

The following errors will cause the upper and lower limit relays to de-energize:

Error Displayed	Error Description
SER320	This is a resolver-specific error. See Chart A-6.
SER330	The input device is not connected to the monitor's input module.
SER331	This is a LDT-specific error. See Chart A-7.
OEr101	The press's ram did not move within the time programmed in the Move Detection Time-Out function.
OEr330 or OEr320	The press's shut height moved beyond the value programmed in the Negative Over Travel Limit functions.

Chart A-5 Upper and Lower Limit Relay Errors

The following chart contains a resolver-specific error:

Error Displayed	Error Description	Solution
SER320	The cable may not be connected, an open or short may exist in the cable, or the resolver's primary may be open or shorted.	To determine the exact condition, enter the Error Conditions function (306). For instructions, see Error Conditions (306) following this chart.

Chart A-6 Resolver-Specific Error

Error Conditions (306)

If the monitor displays “SEr320” one of four error conditions relating to the resolver has occurred. These conditions include primary open, primary shorted, S1, and S4 open or shorted. To have the monitor display the error condition which has occurred, perform the following steps:



1. Select the function key.

306

The monitor displays “F-----”.



2. Select function number 306. Select the enter key.

The monitor will display the exact condition which has occurred. The following are the possible errors:

P OPEn	(Primary Open)
P Shrt	(Primary Shorted)
S4OPEn	(S4 Open)
S1OPEn	(S1 Open)

Error Displayed	Error Description	Solution
SEr331	An error has occurred on the input device. Fault pulse received from LDT.	Correct this error by placing the magnet assembly back into the active stroke area, and clear the error.

Chart A-7 LDT-Specific Error

GEMCO

AMETEK[®]

AUTOMATION & PROCESS TECHNOLOGIES

1080 N. Crooks Road • Clawson, MI 48017 • USA

800-635-0289 • 248-435-0700 • Fax 248-435-8120

www.ametekapt.com • www.ametek.com

1162
2110.M1R2
03/04.Z32
5C