

955 Series



INSTALLATION MANUAL

LINEAR DISPLACEMENT TRANSDUCERS

955DQ BRIK

GEN III WITH QUADRATURE OUTPUT



**Includes 955DQ
Programming & Maintenance
Instructions Plus Accessory Guide**

**ABSOLUTE PROCESS CONTROL
KNOW WHERE YOU ARE... REGARDLESS**



Preface

This manual is divided into three chapters. Chapter 1 provides the hardware overview for the 955DQ Linear Displacement Transducers (LDT). Chapter 2 provides instructions for installing the LDT to a mounting bracket. Chapter 3 provides an overview and wiring instructions. To further assist you, a glossary is provided at the back of the manual.



CAUTION
Disconnect Power Before Servicing. The Gemco 955DQ LDT Contains No Serviceable Components. Consult Factory for Repair or Replacement.

AMETEK Automation & Process Technologies has checked the accuracy of this manual at the time it was approved for printing. However, this manual may not provide all possible ways of installing and maintaining the LDT. Any errors found in this manual or additional possibilities to the installation and maintenance of the LDT will be added in subsequent editions. Any comments you may have for the improvement of this manual are welcomed.

AMETEK reserves the right to revise and redistribute the entire contents or selected pages of this manual. All rights to the contents of this manual are reserved by AMETEK. The BRIK is a registered trademark of AMETEK.



Table of Contents

Chapter 1 Hardware Overview	4
Chapter 2 Installing the LDT	6
2.1 Mounting Instructions	6
2.2 Mounting the Magnet Assembly	6
Chapter 3 Programming & Maintenance	7
3.1 Quadrature Output	7
3.2 Signal Connection Application Note	7
3.3 Quadrature Output Resolution & Speed.....	8
3.4 955DQ Wiring Connections	9
3.5 Features	16
3.6 955DQ	17
3.7 Troubleshooting for 955DQ	18
3.8 Catalog Numbering System	19
3.9 Specifications for 955DQ.....	20
3.10 Accessories	21
Glossary	22



Chapter 1 Hardware Overview

Overview

The Series 955DQ BRIK with Quadrature Output is an accurate, auto-tuning, non-contact, Linear Displacement Transducer in an economical, low profile package. The transducer utilizes our field proven magnetostrictive technology to give absolute position, repeatable to .006% of the sensing distance. The streamlined anodized aluminum extrusion houses the sensing element and electronics. The magnet moves over the sensing element that determines the position and converts it to incremental outputs.

Features

The 955DQ has a truly unique feature. This LDT has auto-tuning capability, the ability to sense a magnet other than the standard slide magnet and adjust its signal strength accordingly.

There is an indicator LED that is located at the connector end of the probe and provides visual status information regarding the operation of the probe. Green indicates proper or normal operation. Red indicates the loss of the magnetic signal or a probe failure. When the probe is in the normal mode of operation, the LED will remain illuminated continuously.

LED Colors	
Green	Magnet is present and within the active range.
Red	Fault, the LDT has lost its signal from the magnet or the magnet has moved into the Null Zone or Dead Band.
Yellow	Used when in the communication/program mode.

Note: The series number on your LDT is a record of all the specific characteristics that make up your unit. This includes what interface type it is, its output signal and range, the type of connector the unit uses, and stroke length. For a translation of the model number, see Section 3.8 Catalog Numbering System.

The 955DQ BRIK with Quadrature Output provides an A quad B digital output signal that is proportional to the position of the slide magnet assembly along the length of the probe. The quadrature output makes it possible to have a direct interface to virtually any incremental

encoder input or counter card, eliminating costly absolute encoder converters and special PLC interface modules.

This model can be ordered with 1 to 9999 cycles per inch of output resolution. The transducer features an input to re-zero the probe “on the fly”. Another unique feature is the “Burst” mode. An input on the transducer triggers a data transfer of all the incremental position data relative to the transducer’s absolute zero position. This is how the incremental output can provide absolute functionality. The “Burst” input can be used to achieve absolute position updates when power is restored to the system or anytime an update is needed to re-zero or home the machine without having to move the machine.

Figure 1.1 Dimension Drawing

Accessories	
Item	Part Number
Slide Magnet	SD0521800
Float Magnet	SD0522100
Mounting Foot	SD0522000
6 Ft. Cable (Option H)	SD0527700L6
12 Ft. Cable (Option H)	SD0527700L12
25 Ft. Cable (Option H)	SD0527700L25
6 Ft. 12 Pin (Option E Connector)	949023L6
12 Ft. 12 Pin (Option E Connector)	949023L12
Control Arm	955ARMXX (X = Inches)

A standard female swivel mounting arm is provided with the slide magnet assembly. For extensions and other options contact AMETEK at 800-635-0289.

Mounting Brackets (SD0522000) slide in the grooves on the side of the extruded housing. When tightened down with fastening hardware the mounting bracket clamps the unit into place. It is recommended to use one mounting bracket on each end and every three feet between.

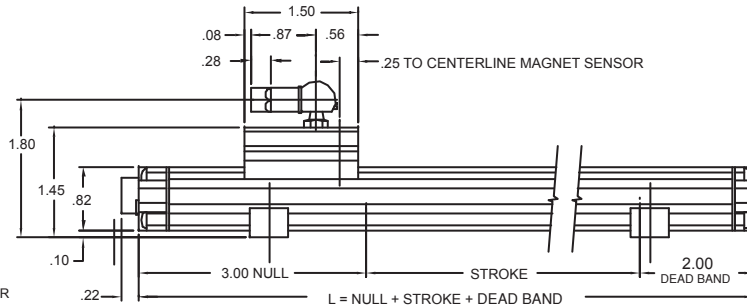
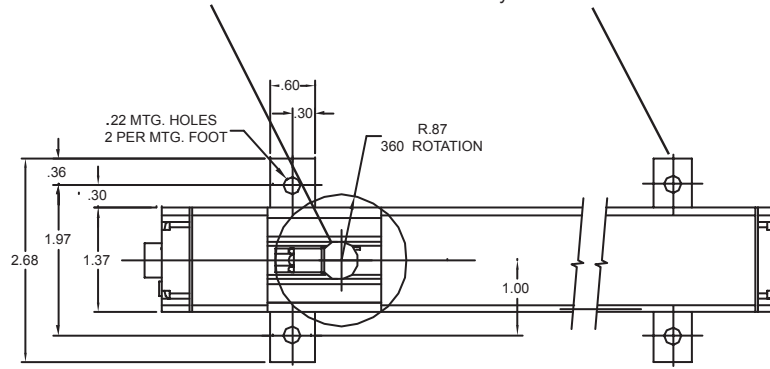
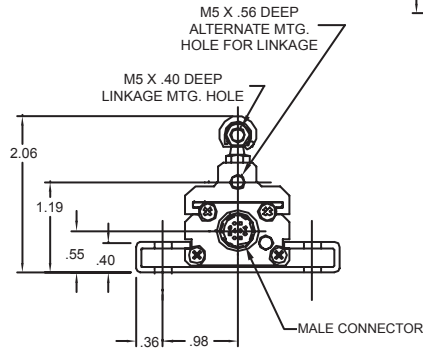

SLIDE MAGNET ASSEMBLY
P/N SD0521800

FLOATING MAGNET ASSEMBLY
P/N SD0522100

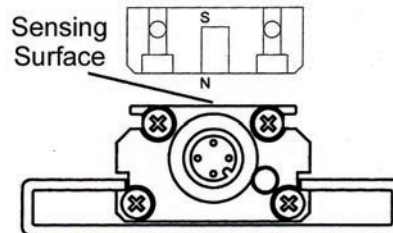
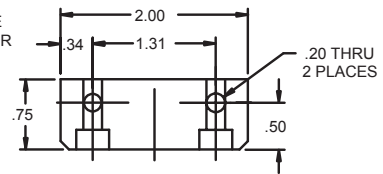
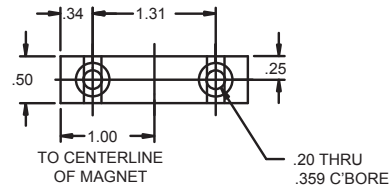
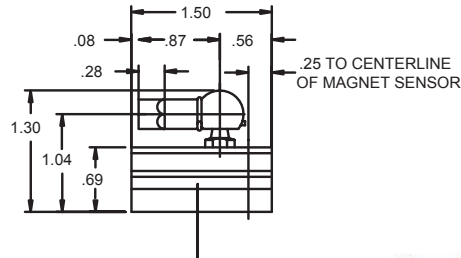
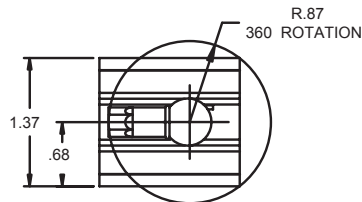
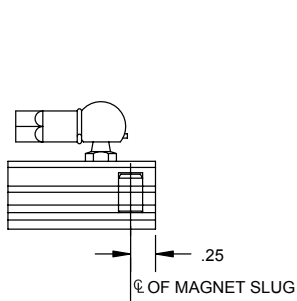

Note: The North Pole of the magnet should be pointed towards the probe.



Chapter 2 Installing the LDT

2.1 Mounting Instructions

The Series 955DQ can be mounted vertically or horizontally using SD0522000 mounting brackets. The mounting brackets slide in the grooves on the lower part of the extrusion and clamp down when tightened. It is recommended to use one mounting bracket on each end and every three feet in between.

Ferro-magnetic material, (material readily magnetized) should be placed no closer than .25" from the sensing surface of the LDT.

2.2 Mounting the Magnet Assembly

Before mounting the magnet assembly, you should consider the following

- Ferromagnetic material should not be placed closer than 0.25" from the LDT's sensing surface. Failure to do so could cause erratic operation. Non-ferrous materials, such as brass, copper, aluminum, nonmagnetic stainless steel or plastics, can be in direct contact with the magnet assembly and sensing surface without producing any adverse results.
- Make sure that the magnet is located within the LDT's active stroke area. Captive magnet assemblies should be positioned so that they can move freely over the entire area of the active stroke without binding or pushing on the extrusion. Non-captive magnet assemblies should be situated so that the magnet is no further than 3/8" from the sensing surface at any point in the floating magnet assembly's movement.
- When using the Floating Magnet assembly (SD0522100), the magnet should be installed within 3/8" of the sensing surface. The magnet assembly should also be installed in such a manner that it remains an even distance from the aluminum extrusion throughout the entire stroke. Improperly installed magnets can result in output signal non-linearity.



Chapter 3 Programming & Maintenance

3.1 Quadrature Output

A new method of interfacing magnetostrictive transducers offers customers an interface as common as analog with the speed and accuracy of pulsed type signaling. The GEMCO 955DQ LDT provides quadrature output directly from the transducer to the controller (see drawing below). The output from the transducer can be wired directly to any incremental encoder input card, without the need for a special converter module or PLC interface card designed specifically for use with a pulsed output magnetostrictive transducer.

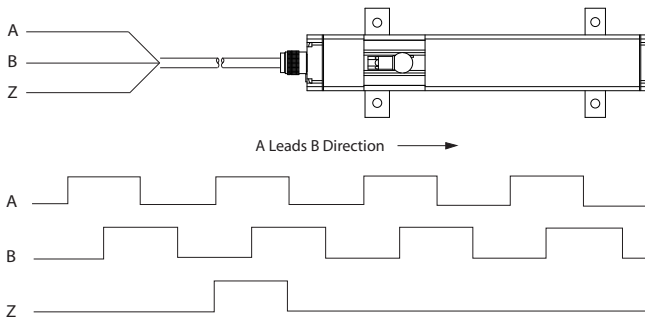

The quadrature output provides absolute position data in engineering units. This means that the need for the calibration constant (wire speed) programming has been removed, thereby eliminating the possibility of having an improperly calibrated system. The output signal wires are driven by differential line drivers, similar to the drivers used in most magnetostrictive pulsed type transducers, providing a high degree of noise immunity.

A unique feature of this transducer is a “burst” mode of operation. An input on the transducer triggers a data transfer of all the incremental position data relative to the transducer’s absolute zero position. This can be used to achieve absolute position updates when power is restored to the system or anytime an update is needed to re-zero or home the machine. Additionally, another input to the transducer can be used to establish a “zero” position for the transducer.

3.2 Signal Connection Application Note

Overview

This application note will clarify the input and output signals of the 955DQ quadrature probe.

Inputs

The quadrature probe has two inputs, the “zero” and “burst” inputs. These inputs are “single ended”. That is, the connection for each input consists of only one wire, the corresponding signal wire. For these (single ended) inputs, the signal is measured with reference to the power supply ground, which is sometimes referred to as “common”.

The quadrature probe is available with either +24 VDC level signal thresholds or TTL level thresholds. The signal voltage level required to activate the input for the +24 VDC level signal is proportional to the power supply voltage that the customer is supplying to the probe. This level is approximately 41% of the power supply voltage. For example, if the power supply voltage powering the probe is exactly 24 VDC, the threshold voltage would be approximately 9.84 volts. The TTL level threshold signals are activated when these inputs exceed the typical TTL level threshold, which is 2.0 VDC.

Additionally, for the 24 VDC level signals, the customer can specify either a “sourcing” or “sinking” type of input. A “sourcing” input type is pulled high internal to the probe. To activate a “sourcing” input, the customer must pull the signal lower than the threshold voltage to activate the input. A “sourcing” input is usually driven by a “sinking” output or a switch connected to ground. A “sinking” input type is pulled low internal to the probe. To activate a “sinking” input, the customer must pull the signal higher than the threshold voltage to activate the input. A “sinking” input is usually driven by a “sourcing” output or a switch connected to the power supply.

It is important that the customer drive the signal levels much greater or lower than the threshold voltages. Asserting a signal with a voltage level close to the threshold voltage could induce multiple activations of that input (or none at all) and therefore produce unexpected results or probe readings.



Outputs

The quadrature probe has three outputs, the “A”, “B” and “Z” outputs. These outputs are “differential” (also known as “balanced”). That is, the connection for each output consists of two signal wires. These are typically described as the “+” and “-” signals. For example, the “A” channel consists of “A+” and “A-”. The same applies to the B and Z channels. For these (differential) outputs, the signal is measured with reference to the other signal (i.e. the difference or differential). For example; if the “A+” signal voltage is greater than the “A-” signal, channel “A” is a logic “1”. Conversely, if the “A+” signal voltage is lower than the “A-” signal, channel “A” is a logic “0”. Again, this applies to the B and Z channels as well. Differential type signals are much less prone to interference caused by electrical noise or ground loops more often found in single ended signal connections.

The differential outputs of the A, B and Z channels are at RS-422 signal levels on option D (output drivers) units. RS-422 is a well known TIA/EIA standard and common interface type for incremental encoders. The RS-422 receiver channel (on the PLC or controller side of the connection) typically has what is referred to as a termination resistor connected across the “+” and “-” signal pins. The value of the termination resistor is (by RS-422 specifications) typically 100 ohms. However, some receivers will work with greater resistance values and some with no termination resistor at all. For proper signal integrity, especially at higher data rates (i.e. quadrature pulse frequency), a termination resistor of no greater than 1K ohm is recommended.

Driving Single Ended Inputs

A differential output can also be used to drive single ended inputs. Special consideration must be given to these types of applications. It should be noted the main signal requirements for an RS-422 signal is the differential voltage of the “+” relative to the “-” signals and not necessarily the voltage level of any one of these signals with respect to ground (or common). To meet the RS-422 specification, this differential voltage only needs to be +/- 0.2 volts. However, an RS-422 driver will typically drive either the “+” or “-” signal to around 3.8 volts with respect to ground. This voltage is more than sufficient to drive TTL level inputs as well as other low level inputs. The input voltage level specifications of the PLC or controller being used should be consulted for the actual level required.

When using PLS’s or controllers that are not TTL compatible output driver option “L” should be used. Option “L” uses a 0L7272 line driver I.C. The output from this driver will be 1 volt less than the LDT’s input power.

When physically connecting a differential output to a single ended input, only use the “+” signal, leaving the “-” signal unconnected. **Do NOT connect the “-” signals to ground.** The “A+”, “B+” and “Z+” signals should be connected to their corresponding inputs. Insulate and tie back the “-” signals. See figure 3-4 or 3-5, Single Ended Interface.

3.3 Quadrature Output Resolution & Speed

The internal resolution of the 955DQ Gemco LDT is 0.001”. This would be represented to the encoder input device by specifying an output resolution of 1,000 cycles per inch for the transducer. Although the typical resolution is 1,000 cycles per inch (CPI), the transducer can be ordered with virtually any CPI setting.

For a typical rotary type shaft encoder with incremental quadrature output, the output frequency of the pulses is governed by the resolution of the encoder (pulses per turn) and the rotational speed (RPM) of the encoder. The output pulses rate from the transducer is stretched out over the LDT internal update time. The output frequency must be specified so that it does not exceed the maximum pulse rate of the encoder input card the sensor is connected to. The output pulse frequency range can be ordered from 1KHz to 1MHz.



3.4 955DQ Wiring Connections

Once the LDT has been installed, wiring connections can be made. There are two groups of connections you will need to make. They are as follows:

- Power Supply Connections (including grounding and shielding)
- LDT Input/Output Connections

Power Supply/Ground Connections

The 955DQ is available with two different connector options, either Option H or Option E. Refer to the part number labeled on your unit to determine which connector you have. Always observe proper grounding techniques such as single point grounding and isolating high voltage (i.e. 120/240 VAC) from low voltage (10-30 VDC cables). Whenever possible, this cable should be run in conduit by itself.

The power supply common, the cable shield and a good earth ground should be connected together at the location of the power supply common.

WARNING

Do not route the BRIK with Quadrature Output cable near high voltage sources.

Option E: Uses a 12-Pin 12mm Euro Cordset with the shield tied to the coupling nut. The 12-pin connector has ten conductors of 24ga, with an aluminum/polyester/aluminum foil with drain wire plus an overall braid of tinned copper shield. Cable O.D. is .280. To reduce electrical noise, the shield must be properly used. Connect the cable's shield to the controller system GND. The connector shell on the probe is electrically connected to the probe housing.

Option H: Uses a 10-Pin HRS connector. The 955DQ BRIK with connector Option H uses a standard cable, a multi-conductor Alpha 6334. It has ten conductors of 24ga, with an aluminum/polyester/aluminum foil with drain wire plus an overall braid of tinned copper shield. Cable O.D. is .270. To reduce electrical noise the shield must be properly used. Connect the cable's shield to the controller system GND. The cable shield is not connected at the transducer end.

Figure 3.1 Power Supply Wiring

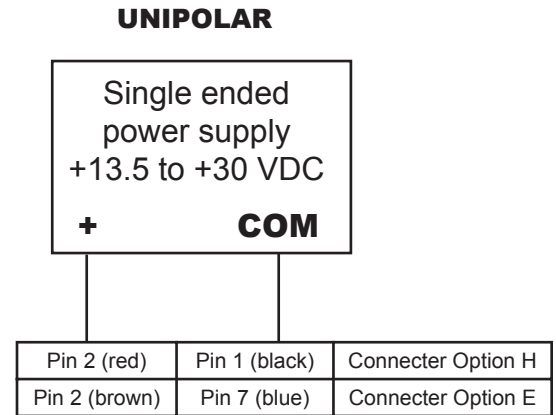
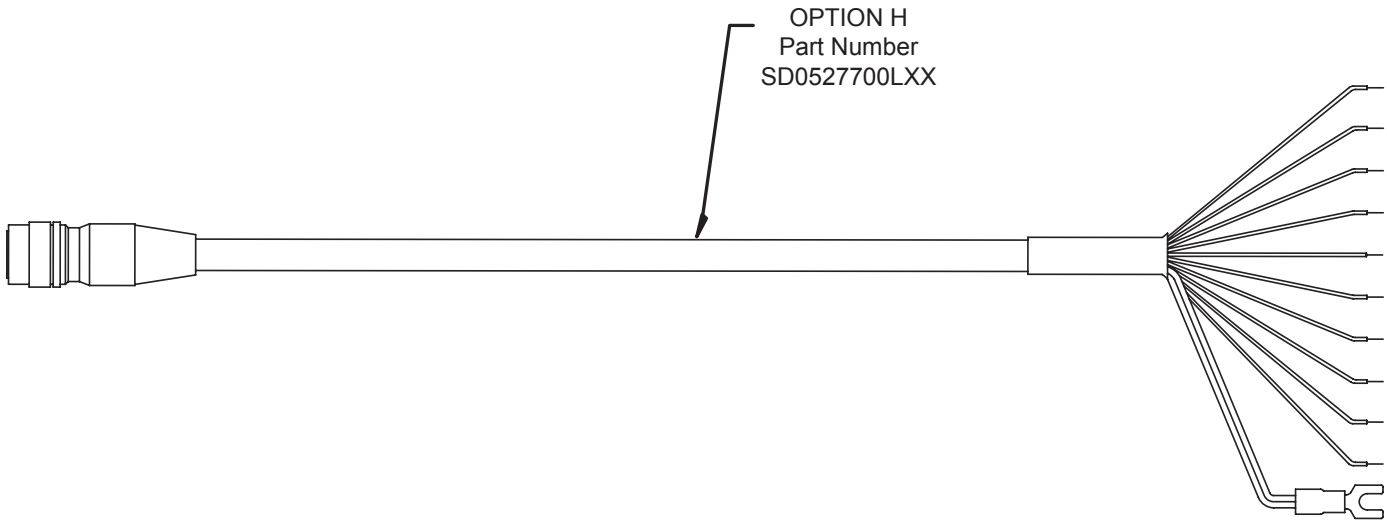
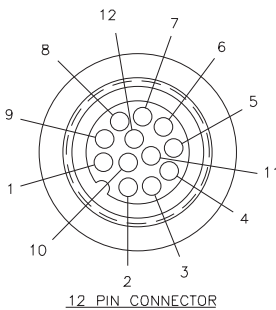

Figure 3.2 Power Supply Wiring



Wiring Diagram

Connector Option E



12 PIN CONNECTOR

Connector View

WIRE COLOR	12 PIN EURO CONN. DESIG.	PIN OUT
WHITE	1	B+
BROWN	2	PWR+
GREEN	3	Z+
YELLOW	4	Z-
GRAY	5	A+
PINK	6	A-
BLUE	7	GND
RED	8	BURST
ORANGE	9	ZERO
TAN	10	B-
NC	11	-
NC	12	-

12 Pin Micro 12mm Euro Straight Cable

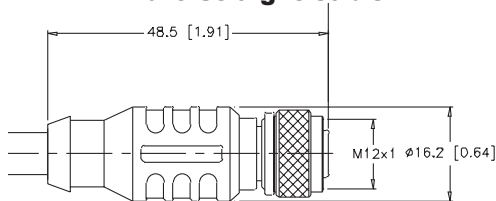

12 Pin Part Number: 949-023LXX
(X = Length in Feet)

Connector Option H

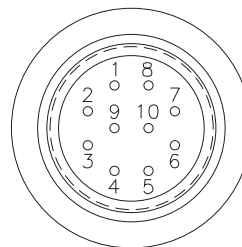

10 PIN HIROSE CONNECTOR

Connector View

WIRE COLOR	10 PIN CONN. DESIG.
BLACK	1
RED	2
GREEN	3
BROWN	4
BLUE	5
ORANGE	6
YELLOW	7
WHITE	8
VIOLET	9
GRAY	10

10 Pin Straight Cable

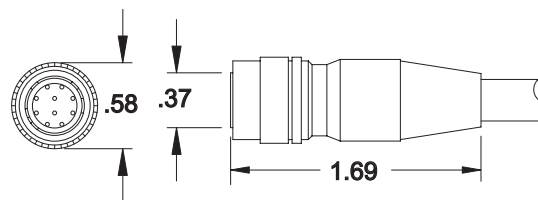

Part Number: SD0527700LXX
(X = Length in Feet)

Figure 3.3 Wiring Diagram

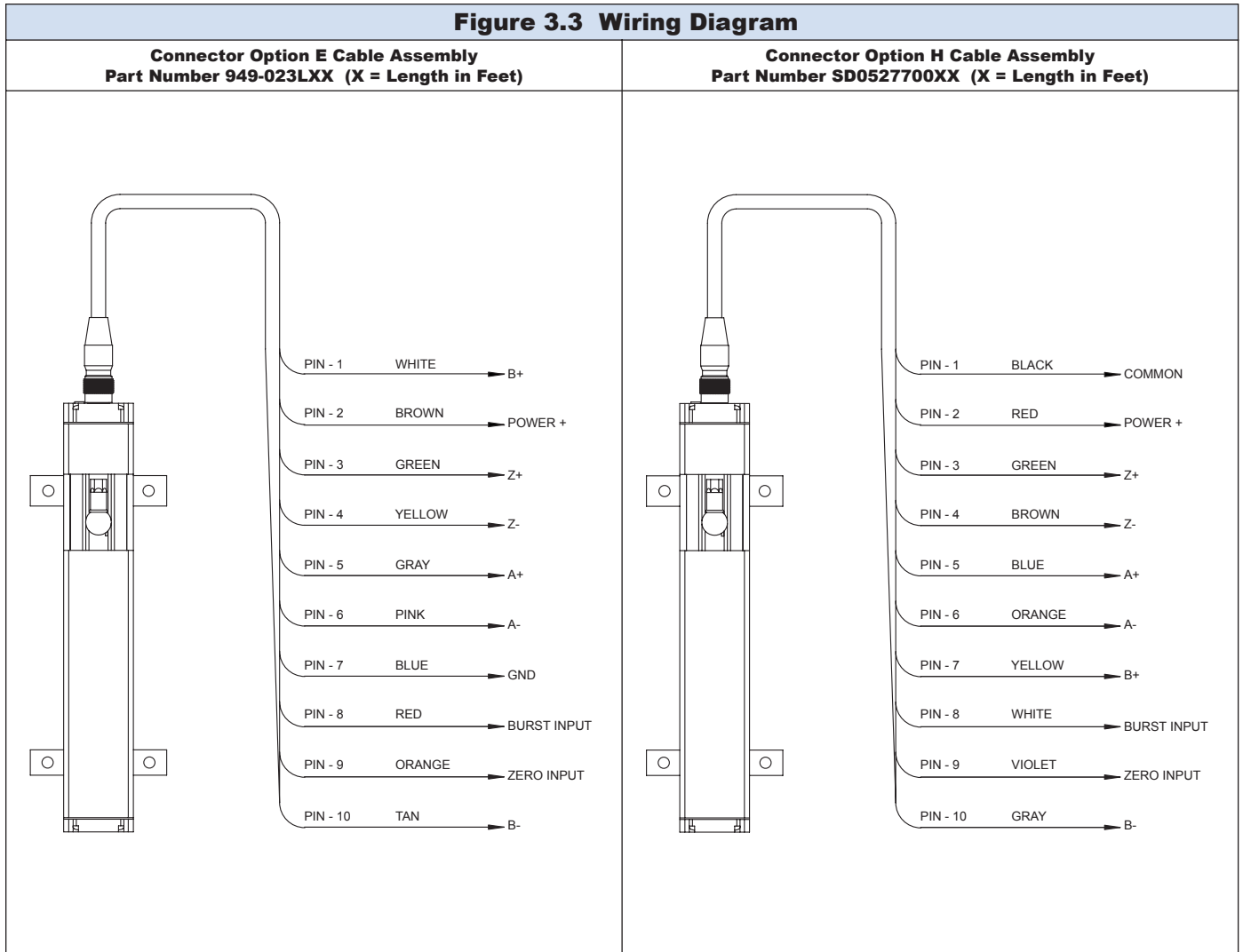

Figure 3.4a Option H Input Connections for Sinking Input

CABLE ASSY
Part Number SD0527700LXX
X = Length in Feet

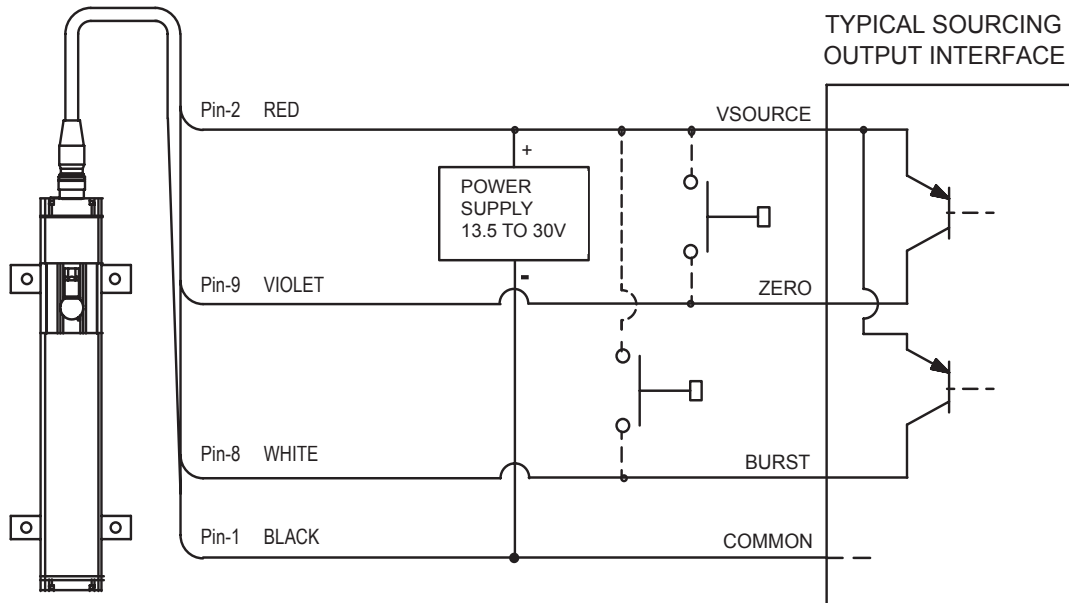

Figure 3.4b Option H Input Connections for Sourcing Input

CABLE ASSY
Part Number SD0527700LXX
X = Length in Feet

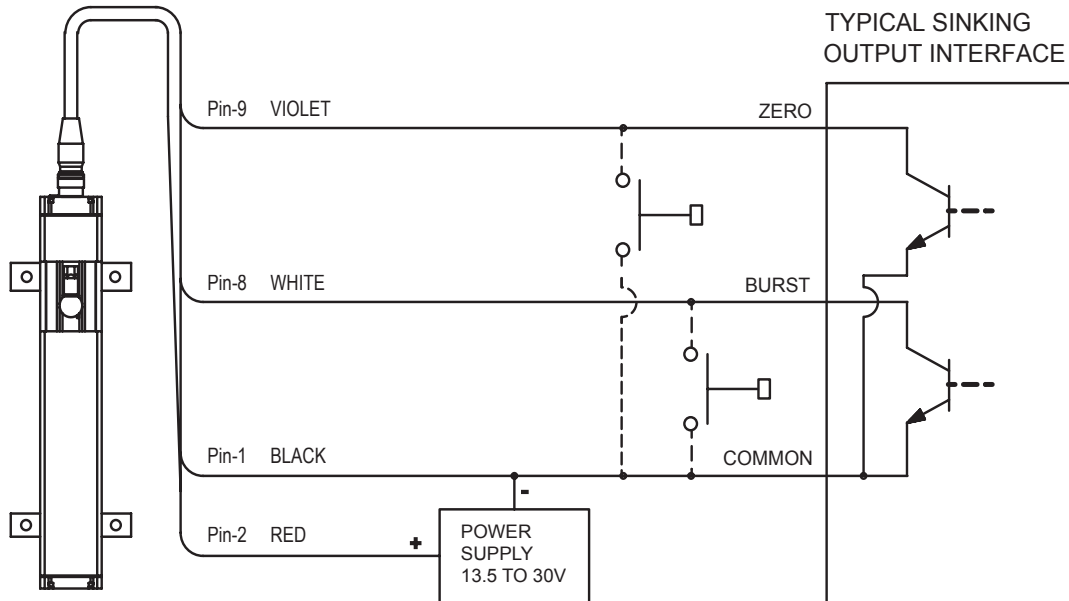

Figure 3.4c Option H Output Connections for Differential Interface

CABLE ASSY
Part Number SD0527700LXX
X = Length in Feet

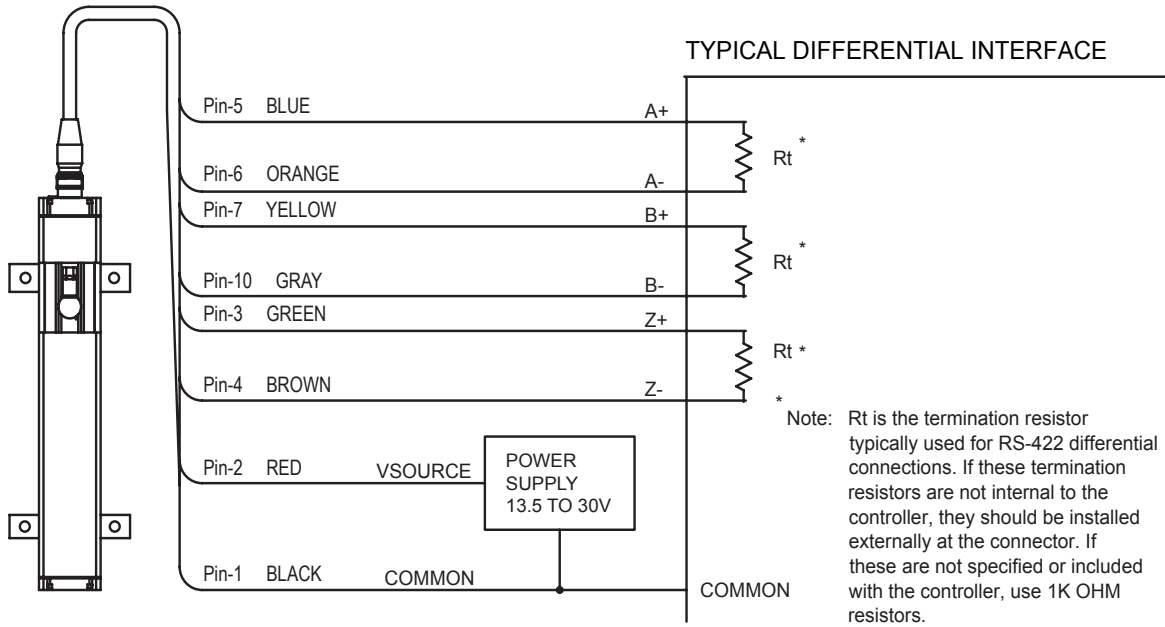

Figure 3.4d Option H Output Connections for Single Ended Interface

CABLE ASSY
Part Number SD0527700LXX
X = Length in Feet

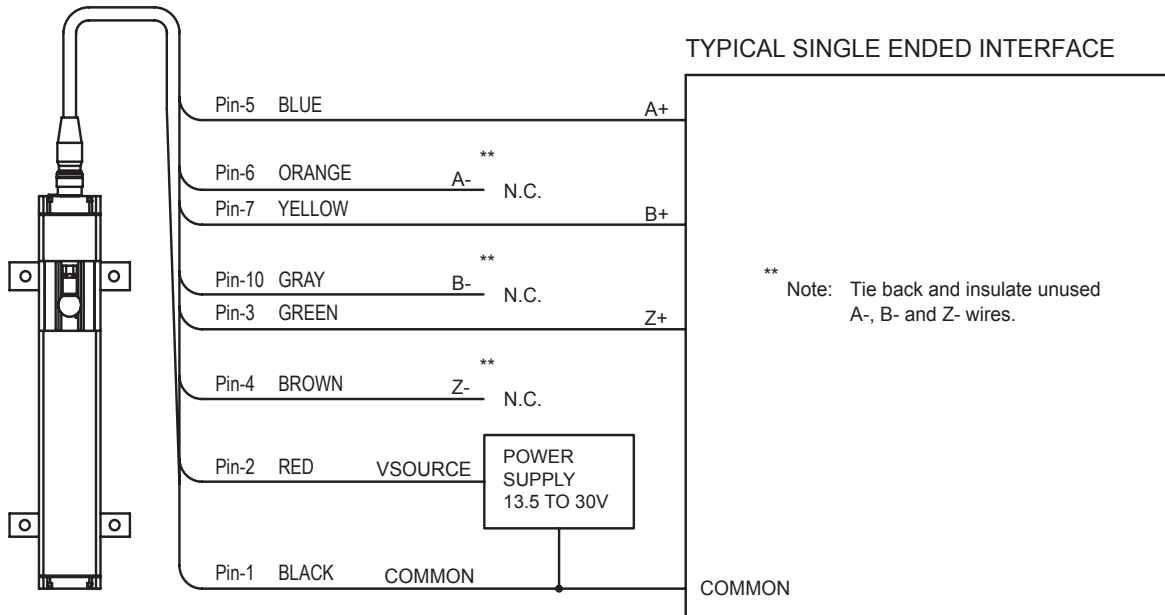

Figure 3.5a Option E Input Connections for Sinking Input

CABLE ASSY
Part Number 949-023LXX
X = Length in Feet

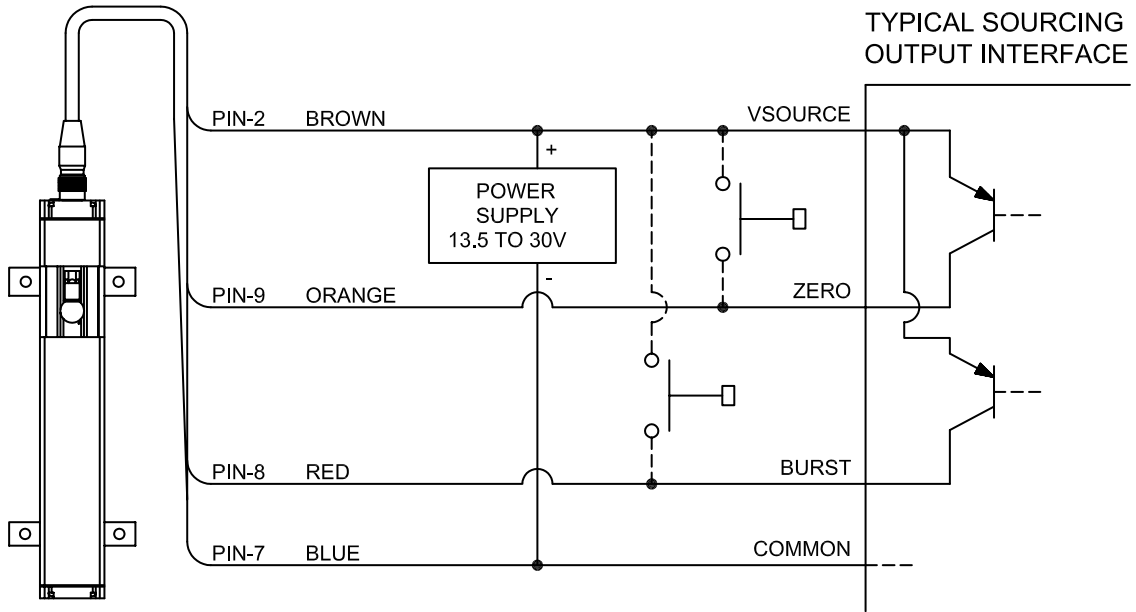

Figure 3.5b Option E Input Connections for Sourcing Input

CABLE ASSY
Part Number 949-023LXX
X = Length in Feet

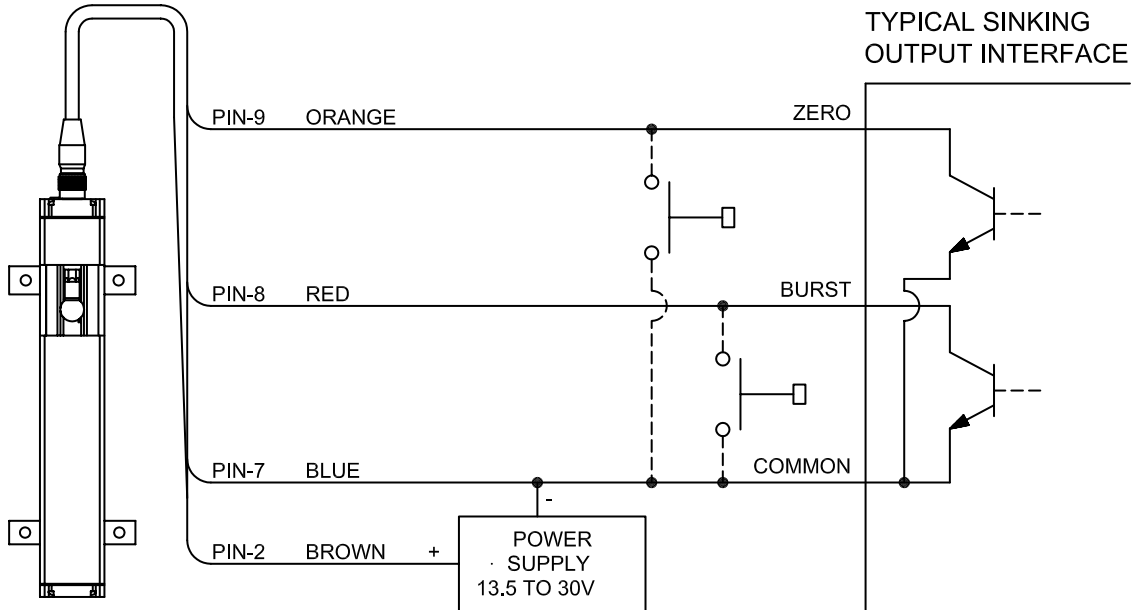

Figure 3.5c Option E Output Connections for Differential Interface

CABLE ASSY
Part Number 949-023LXX
X = Length in Feet

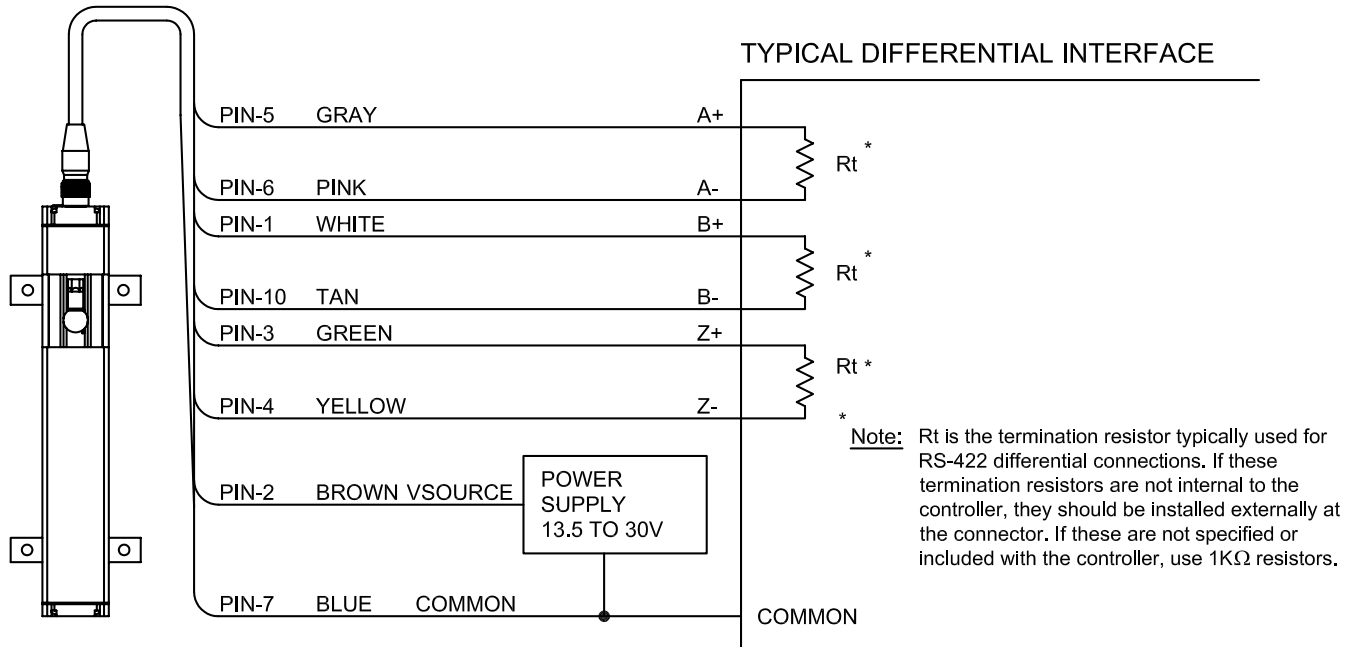
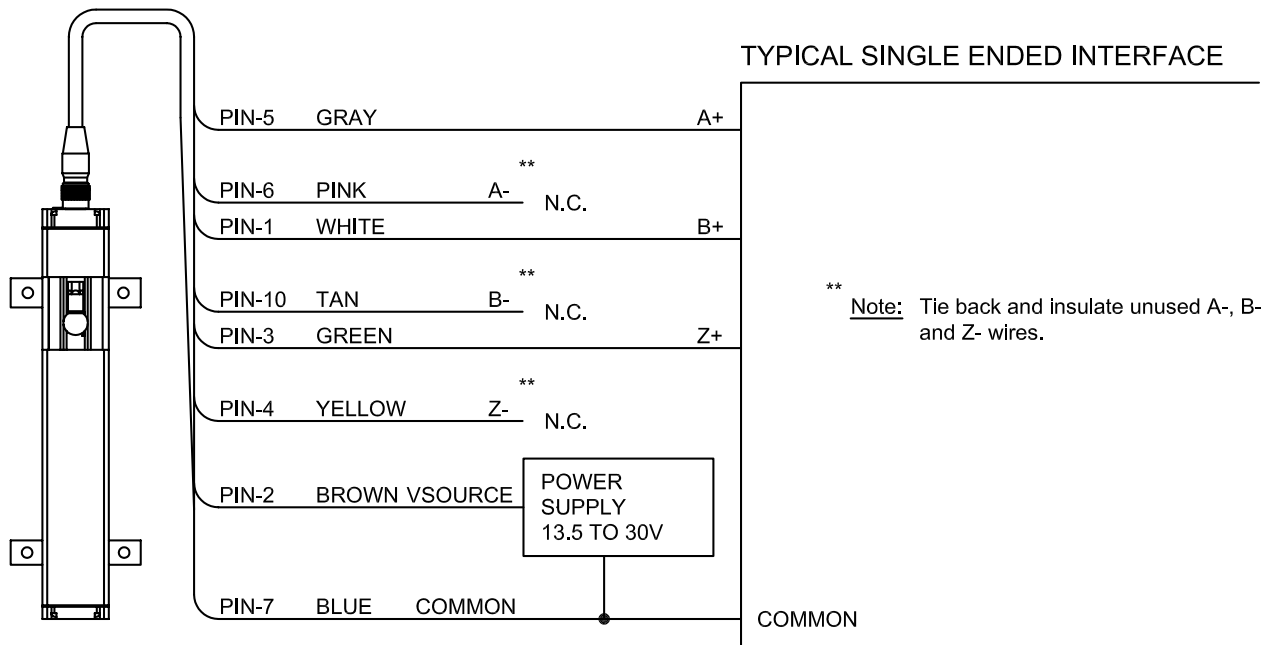

Figure 3.5d Option E Output Connections for Single Ended Interface

CABLE ASSY
Part Number 949-023LXX
X = Length in Feet





3.5 Features

Automatic Gain Control

The Automatic Gain Control feature will automatically search and find the magnet on power up, if power is applied without a magnet on the LDT, the LED will turn RED indicating no magnet signal is detected. Turn power off and place magnet within the active stroke area. Re-apply power.

When using the Floating Magnet assembly (SD0522100), the magnet should be installed within 3/8" of the sensing surface. The magnet assembly should also be installed

so that it remains an even distance from the aluminum extrusion throughout the entire stroke. Improperly installed magnets can result in output signal non-linearity.

LED Colors	
Green	Magnet is present and within the active programmed range.
Red	Fault, the LDT has lost its signal from the magnet or the magnet has moved into the Null Zone or Dead Band.
Yellow	Factory use only. Used to determine when the LDT is in the programming mode.

Burst Mode

This feature enables the system to be absolute even though data transfer is through an "incremental" method. In the event of power failure, the controller can be programmed to automatically send a signal to the probe,

which will then respond with the current position data. An input signal to the probe will cause a "burst" of data, representing the absolute position, to be fed back to the controller.

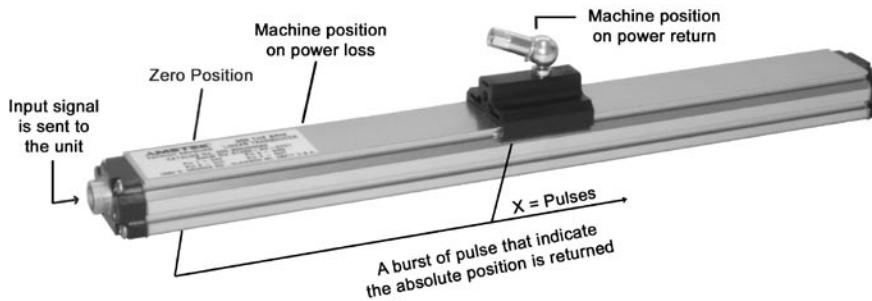

Zero Pulse

By sending a signal to the probe at any point in the stroke, a new zero point can be established. When using the burst input, the absolute position provided will be relative to the programmed zero position. In probes with volatile storage the zero point will be kept until a new

zero pulse is sent or until the probe loses power. Probes with nonvolatile storage will store the zero position even if you lose power. The nonvolatile zero can be set 100,000 times; the volatile zero can be set an infinite number of times.

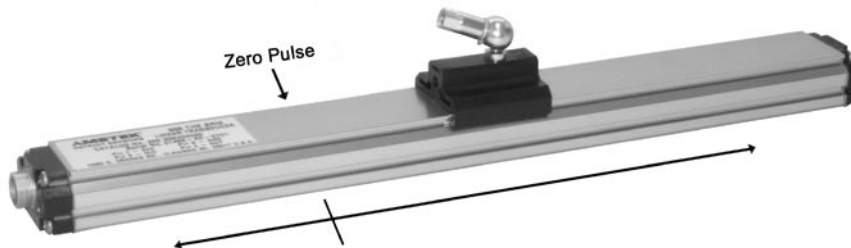

Signal Types Needed for Burst & Zero Inputs
E = Sinking (PLC Sourcing Outputs)
C = Sourcing (PLC Sinking Outputs)
T = TTL

See section 3.9 Specifications, for more information.



3.6 955DQ

Frequency or Pulse Rate

Selecting the proper frequency in the LDT's part number is very important. The 955DQ has an internal update time of 1 millisecond on LDT's less than 60" in length and approximately 2 milliseconds on the units greater than 60" in length. The LDT will stretch the amount of pulses travelled over the update rate. All incremental pulses must be transmitted before the LDT will interrogate itself again. The frequency or pulse rate of the 955DQ is factory set from 1KHz - 1.00MHz, consult part number for your model. The input for the PLC or display will determine the frequency needed.

Example: If your PLC High Speed counter card or display accepts a 1MHz encoder input, the choices are

- | | | |
|-----------|-------------|--------------|
| A1 = 1KHz | F1 = 10KHz | F6 = 150KHz |
| A2 = 2KHz | F2 = 25KHz | F7 = 250KHz |
| A3 = 5KHz | F3 = 50KHz | F8 = 500KHz |
| | F4 = 75KHz | F9 = 1.00MHz |
| | F5 = 100KHz | |

Note: If your controller's maximum input frequency falls between two available frequencies, choose the lower frequency.

Output Drivers

The 955DQ BRIK uses a 0L7272 line driver IC. Your LDT was configured at the factory for either a TTL level output or a 13.5 - 30 VDC level output. Refer to label on LDT for your output type.

D = Differential RS-422 line driver, TTL compatible

L = Differential line driver 13.5 - 30VDC
 $V_{out} = V_{in} (\text{LDT Power}) - 1 \text{ volt}$

Option D has a 5 volt TTL level output regardless of input power.

Option L has an output of 1 volt less than probe input power. This option is used when driving higher voltage input cards and is not TTL compatible.



3.7 Troubleshooting for 955DQ

Troubleshooting describes common problems that may occur when installing the LDT and offers possible solutions to these problems. If, after reading this appendix, you are unable to resolve a problem, contact our technical support department at 1-800-635-0289.

General Checks

Make sure that the magnet is located within the LDT's active stroke area. Captive magnet assemblies should be positioned so that they can move freely over the entire area of the active stroke without binding or pushing on the extrusion. Non-captive magnet assemblies should be situated so that the magnet is no further than 3/8" from the sensing surface at any point in the floating magnet assembly's movement.

Note: Ferromagnetic material (material readily magnetized) should be located no closer than 0.25" from the sensing surface of the LDT. This includes mounting brackets, magnet spacers, magnet brackets, and mounting screws. Ferromagnetic material can distort the magnetic field, causing adverse operation or failure of the LDT.

Check all LDT wires for continuity and/or shorts. It is preferable that the cable between the LDT and the interface device be one continuous run. If you are using a junction box, it is highly recommended that the splice junction box be free of AC and/or DC transient-producing lines. The shield should be carried through the splice and terminated at the interface device end.

Power Supply Check

This section will help you to determine if your power supply is adequate for the LDT to operate properly, or if the LDT's cable has a short or open.

In order for the 955DQ to operate properly, the external power supply must provide a level between 13.5 to 30 VDC. A power supply providing voltage above this specified range may damage the LDT. A power supply providing power below this specified range will not be sufficient to power the LDT. When powering more than one BRIK on a single power supply, remember that each BRIK requires three (2.5) watts of power maximum (2 watts typical). The amount of current draw will vary based on the input voltage used. To calculate the current

draw for a particular LDT, divide the LDT wattage by the input voltage. For example, 2 watts divided by 24 VDC equals 104mA.

If your LDT is not operating properly, the LDT's cable may have an open or short, or the power supply is not supplying sufficient power. To verify this, perform the following steps:

1. Turn the power supply off.
2. Remove the mating connector from the LDT.
3. Turn the power supply on.
4. Using a digital voltmeter, check from power supply common (GND) and Power Supply + (Vsource) from the mating end of the cable for a level between +13.5 and +30 VDC.

If reading is between 13.5 and 30 VDC, turn power supply off and go to step 7. If reading is below 13.5 VDC, either your power supply is not providing enough power or the LDT's cable possibly has a short/open. Readings of no voltage or minimal voltage (less than 5 volts) may be due to short/open in the cable. If reading is **not** between 13.5 and 30 VDC, go to step 5. If reading is above 30 VDC, adjust power supply or replace.

5. Turn the power supply off.
6. Check the continuity of the individual wires of the cable between the power supply and the LDT. Check for continuity from one end of the cable to the other. Also verify that no shorts exist between pins.
7. Reconnect the mating connector to the LDT.
8. Turn power supply on.
9. Using a digital voltmeter, check the power supply's "+" and "-" terminals for a voltage between 13.5 and 30 VDC.

Low voltage readings may indicate a power supply with a wattage (current) rating that is too low. (Each LDT requires 2.5 watts). If the cabling checks out in step 6 and your voltage is below 13.5 VDC, check your power supply current rating. If voltage is between 13.5 to 30 VDC and the LDT is still inoperative, contact factory.



3.8 Catalog Numbering System

Part Numbering

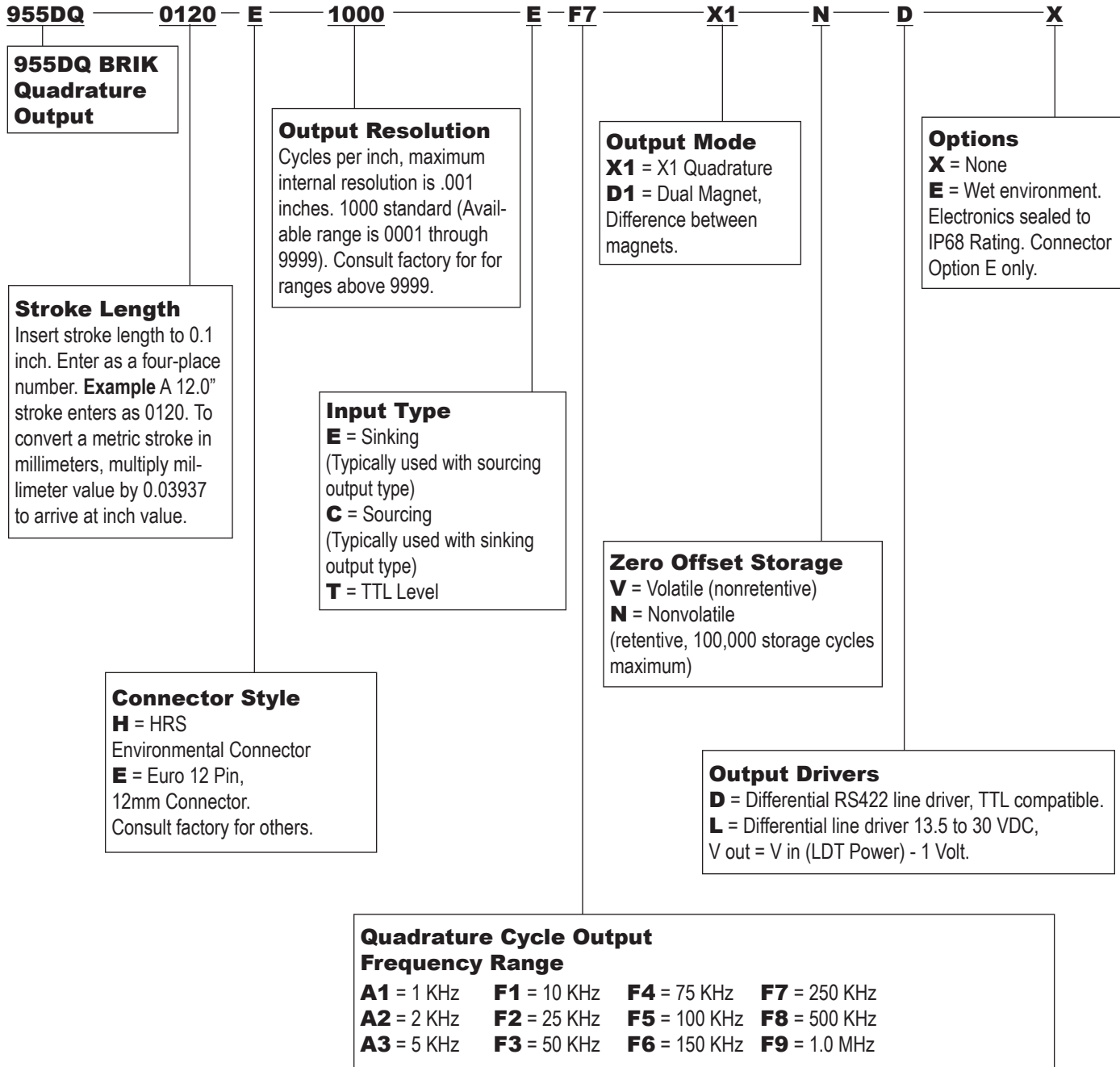

Note: Contact our Technical Support at 1-800-635-0289 for custom configurations.



3.9 Specifications for 955DQ

General Specifications	
Null Zone	3.00"
Dead Band	2.00"
Extrusion Assembly	Anodized Aluminum with gasket seals, IP 67, IP 68 Optional
Connector	Option H - HRS-Style Standard (quick connect/disconnect) Connector Option E - 12 Pin, 12mm Euro Style Connector
Sensor Length	5" to 180"
Agency Approval	CE
Shock & Vibration	Random Vibration MIL-STD 810E, 10Grms random, 20Hz - 2K Hz Shock Tested to 40G

Electrical Specifications	
Input Voltage	Unipolar 13.5 to 30 VDC
Current Draw	2.5 watts maximum
Nonlinearity	+/- 0.05% of full stroke
Repeatability	+/- 0.006% of full stroke
Hysteresis	+/- 0.02% of full stroke
Operating Temperature	-20° to 70° C
Storage Temperature	-40° to 85° C
Drivers	<p>Option D</p> <ol style="list-style-type: none"> Quadrature A RS-422 differential Quadrature B RS-422 differential Zero (index) position RS-422 differential <p>Maximum 5 volts, minimum 2 volts into a 50 ohm load (TTL compatible)</p> <p>Option L</p> <ol style="list-style-type: none"> Quadrature A differential line driver Quadrature B differential line driver Zero (index) position differential line driver <p>Maximum 30 VDC, min 13.5 VDC, driver 0L7272 V out = V in (LDT Power) - 1 volt</p>
Digital Input	<ol style="list-style-type: none"> Zero position set 5 - 30 volts Source or Sink Burst mode input 5 - 30 volts Source or Sink <p>Input impedance 5 K ohms</p> <p>Sink threshold Input < 0.41 * Power Supply Voltage i.e. 0.41 x 24 VDC Power Supply = < 9.84 VDC</p> <p>Source threshold Input > 0.41 * Power Supply Voltage i.e. 0.41 x 24 VDC Power Supply = > 9.84 VDC</p> <p>TTL threshold Input > 2.1 Volts</p>
Update Time	<p>50" or less 1ms (Stroke Lengths 5" to 50")</p> <p>51" to 100" 2ms (Stroke Lengths 51" to 100")</p> <p>101" to 150" 3ms (Stroke Lengths 101" to 150")</p> <p>151" to 180" 4ms (Stroke Lengths 151" to 180")</p>
Specifications are subject to change and are based on a typical 36" LDT.	

3.10 Accessories

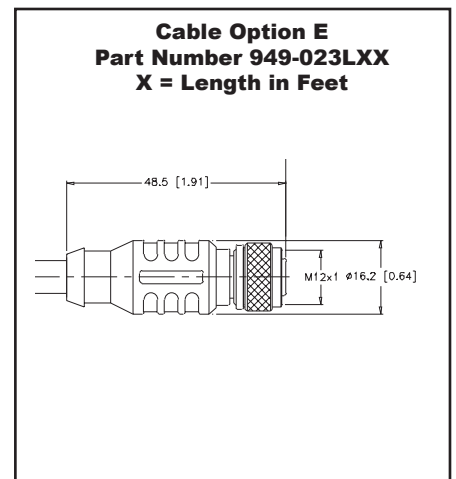
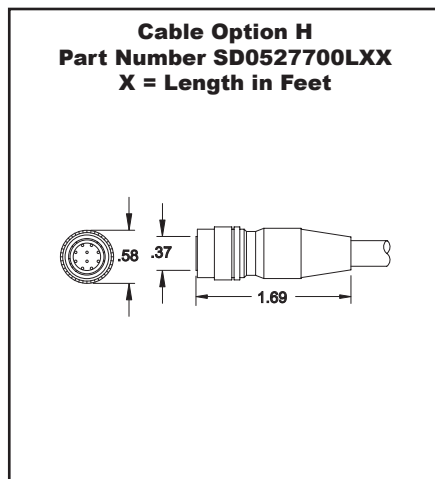
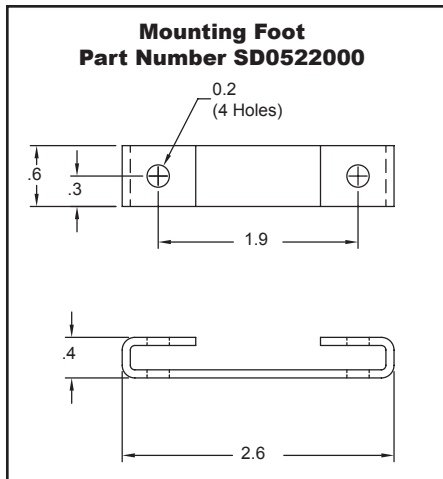
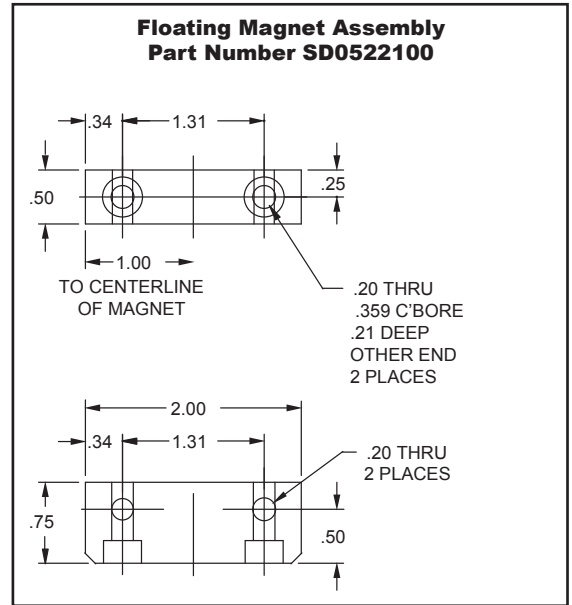
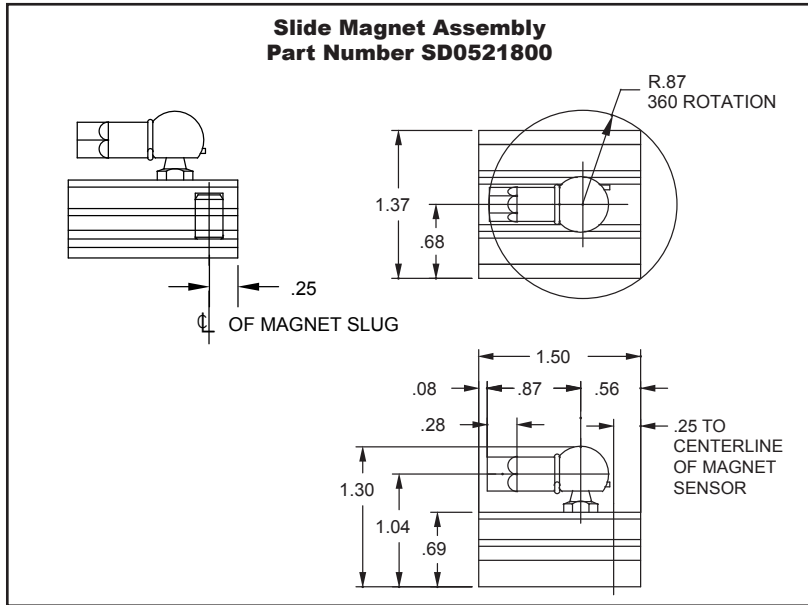



955DQ Glossary

Active Stroke Area	The area on the extrusion between the Null Zone and Dead Band on which the magnet assembly moves.
Burst Input	An input signal to the probe will cause a “burst” of data, representing the absolute position to be fed to the controller.
Dead Band	An area usually 2” from the end of the extrusion where sensing of the magnet is not possible.
Floating Magnet	A non-ferrous assembly that contains the magnet that moves across the LDT’s sensing surface in a non-contact manner.
Incremental	A relative position feedback device whose signal is always referenced to the zero position. The LDT produces a digital, square wave pulse train that is fed into an up/down counter chip or clock to derive position.
Input Type	Used to determine input type for “burst” and “zero” modes. i.e.; sinking, sourcing or TTL.
Non-volatile	Position is held in memory and will not be lost on power down.
Null Zone	An area usually covering 3.00” on the extrusion beginning at the connector end.
Output Driver	Used to determine output type of A, B and Z.
Output Resolution	Used to determine amount of pulses per inch.
Quadrature	Two output channels out of phase by 90 electrical degrees.
Quadrature Cycle Output Frequency	The maximum frequency at which the pulse rate is transmitted out of the probe.
RS-422 Differential	Differential line driver.
Slide Magnet Assembly	A non-ferrous assembly that moves across the LDT’s sensing surface.
Unipolar	A power supply that provides a single voltage.
Volatile	Position held in memory that is lost on power down.
Wire Speed	The average time it takes a pulse to travel one inch on the LDT’s wire.
Zero Pulse	By sending a signal to the probe at any time in the stroke a new zero point can be established.



Notes:



Other Products



- GEMCO**
- LINEAR DISPLACEMENT TRANSDUCERS
- PLC INTERFACE PRODUCTS
- ROTARY POSITION PRODUCTS
- PROGRAMMABLE LIMIT SWITCHES
- EXTREME DUTY CABLE REEL PRODUCTS
- ROTARY LIMIT SWITCHES
- RESOLVERS
- MILL DUTY ENCLOSURES
- ULTRA HIGH SPEED PLS
- SAFETY PRODUCTS



Copyright 2004 by AMETEK AUTOMATION & PROCESS TECHNOLOGIES.
All Rights Reserved. Made in the USA.



1080 N. Crooks Road, Clawson, MI 48017-1097
Phone 248-435-0700 Toll Free 800-635-0289
Fax 248-435-8120 www.AMETEKAPT.com

955DQ.M1RO
10/04.Z169
250

