



Replacement Parts

November 2003

58-GC5026

Cam Switch
Reversing - 2 Speed - 3 Phase
C5026

INTERNAL CONNECTIONS

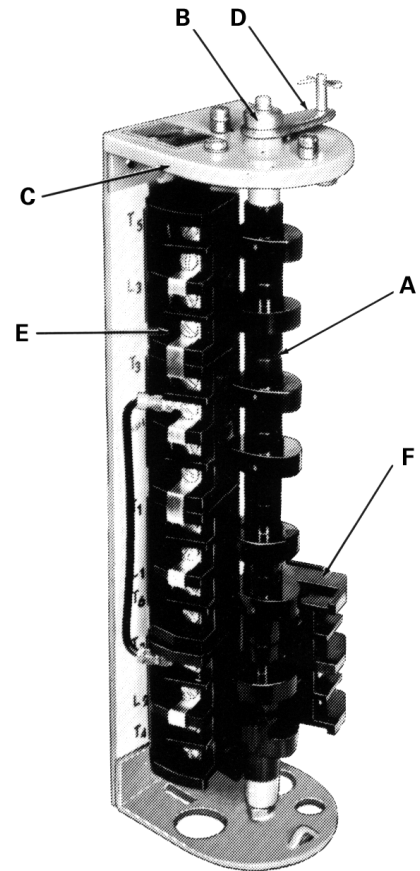
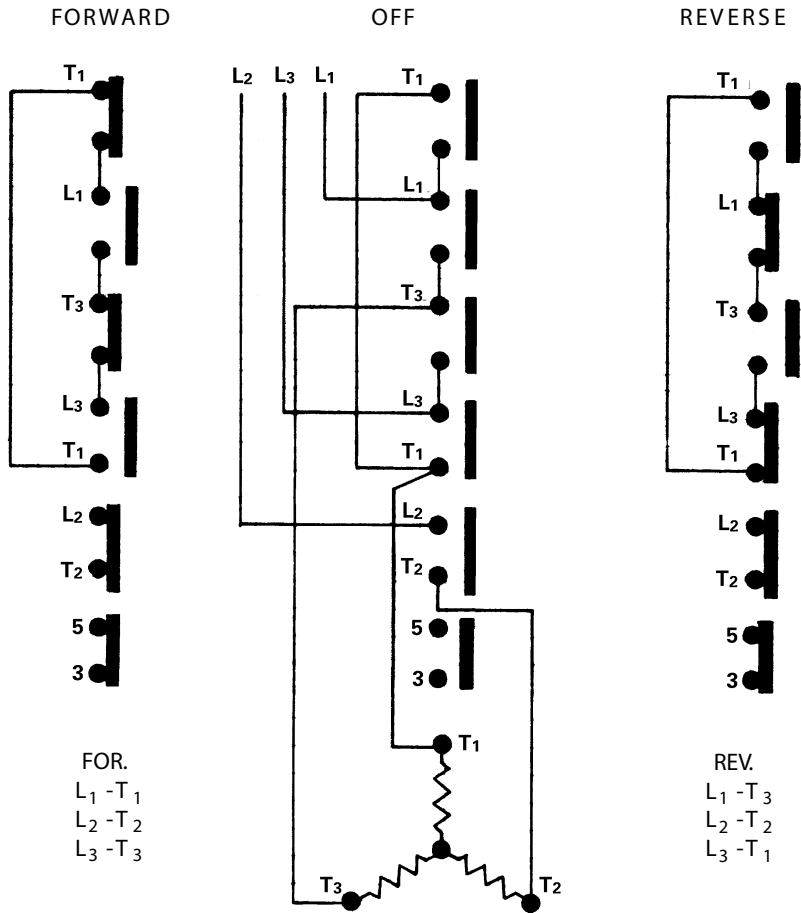

Item	Part Name	No. Req'd	Part Number
A	Rotor Assembly	1	D50078001
B	Roller Lever Assembly	1	D10288001
C	Index Spring	1	D06171002
D	Lever Assembly	1	D17811001
E	Contact Board - 2 Pole	3	D50542001

NOTE: When ordering replacement parts, give catalog number of control and part number.

(For Engineering Reference Only - Rev. B)