

Outline Drawings

Special Purpose – Type 710

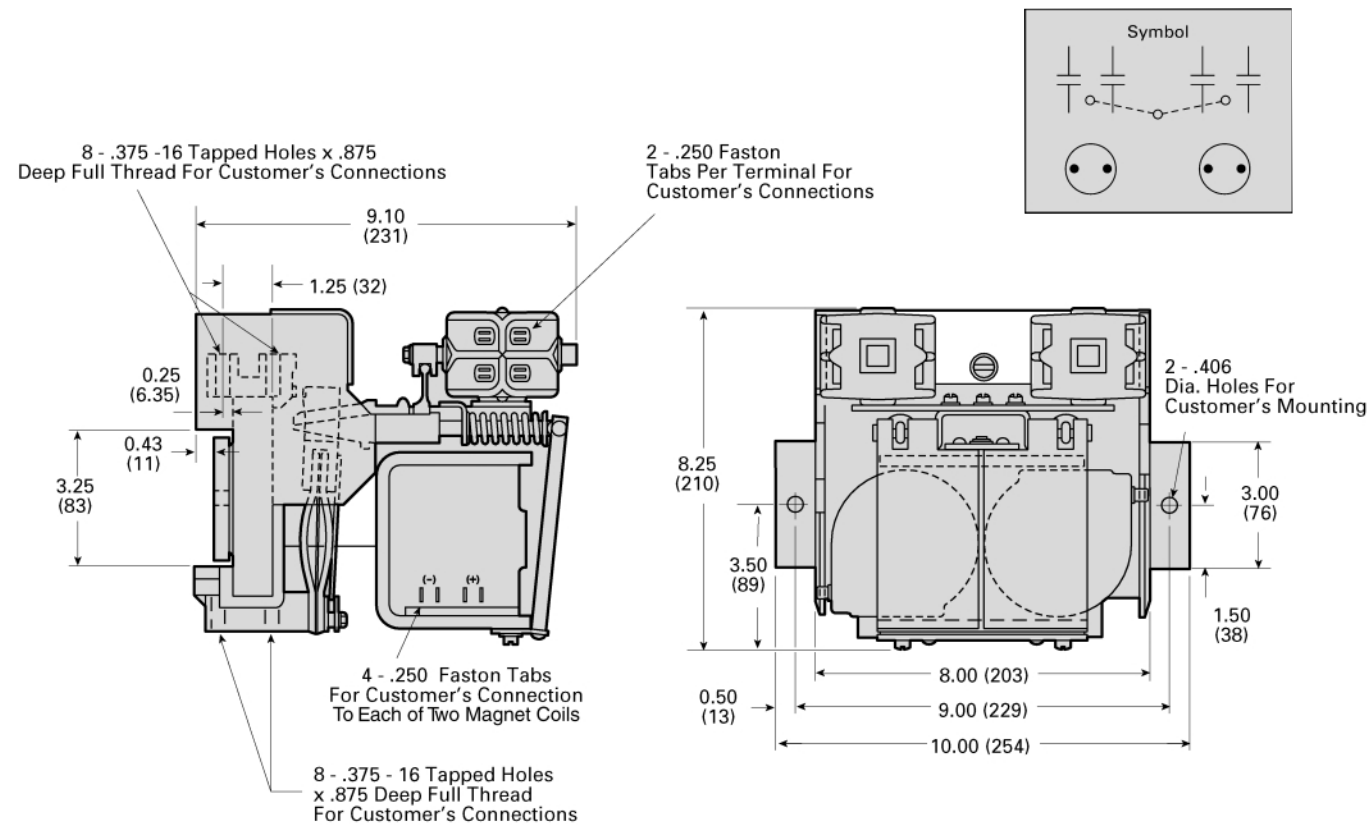

Hubbell Industrial Controls, Inc.

Type 710 700 Ampere 1500 Volt Dual Two Pole Switch

Catalog 42710 • September 2005

42710

Application/Model List

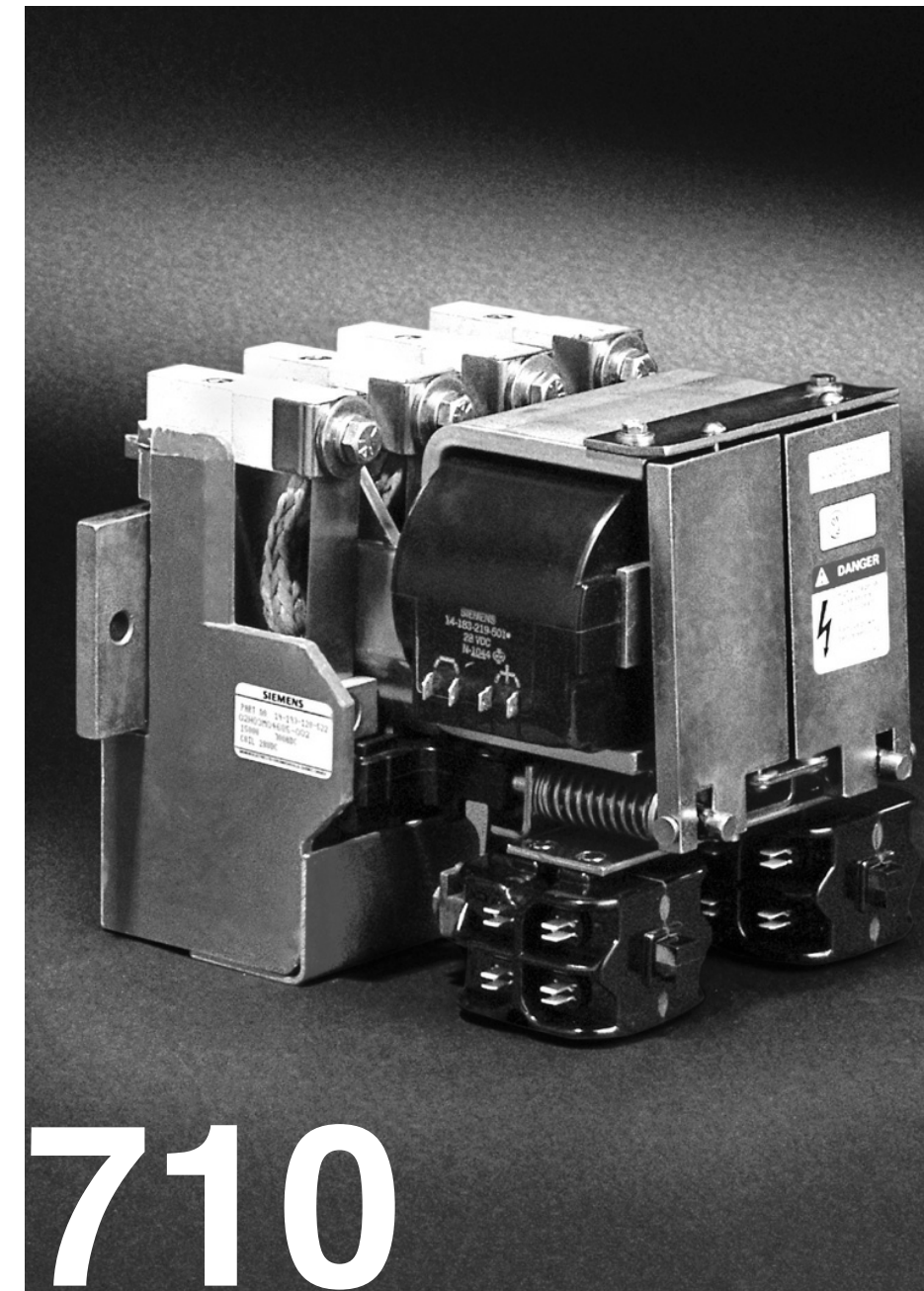

Highlights

- Mechanically interlocked
- Silver alloy main contacts
- Molded coils
- Silver-plated current-carrying connections
- High dielectric and mechanical strength
- Special ratings available – consult Factory

Compact in size, the Type 710 is ideally suited for DC systems in such applications as gas and oil well drilling equipment, transit and rail, adjustable speed drives, electric haul trucks, mining machinery, fuel cells, and crane controls. Typically, it is used in conjunction with compatibility sized power contactors (such as Hubbell Type 700 1250 Ampere 1000 VDC SPNO power contactor) for power circuit reversal. The Type 710 device is two double pole, single throw mechanically interlocked, non-interrupting switches in a single housing. Each switch is rated at 700 Ampere (special ratings available – consult factory) continuous per pole in dead air and carries a 1500 VDC rating.

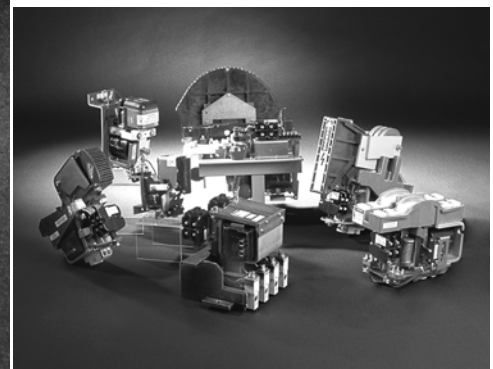

710

DUAL TWO POLE SWITCH

Spec Tech Industrial 203 Vest Ave. Valley Park, MO 63088 Phone: 888 SPECTECH
Email: sales@spectechind.com www.spectechind.com

Amazingly Reliable – Hubbell Industrial Controls Devices

The Hubbell ICD family of rugged, high-performance DC devices are in great demand by industries needing reliable, solid state, adjustable controls. Products include contactors, limit switches, crane controls, fire pump controls, transfer switches, motor controllers and resistors. Hubbell ICD has a device ideal for a wide range of applications. And if it's from Hubbell, you know you're getting amazingly reliable technology.

Spec Tech Industrial 203 Vest Ave. Valley Park, MO 63088 Phone: 888 SPECTECH
Email: sales@spectechind.com www.spectechind.com



hubbell industrial controls, inc.

This rugged, dependable device utilizes silver alloy main contact tips with wiping action to provide exceptionally high reliability, contact continuity, and low contact resistance. Power terminations and major current-carrying parts are silver plated for reliable corrosion-resistant electrical connections. Zinc-dichromate plated non-current-carrying steel parts offer excellent corrosion resistance, while non-tracking molded glass polyester parts provide high dielectric and mechanical strength.

Operating coils are of molded construction for protection from corrosion, foreign material and moisture contamination, and damaging physical abuse.

Each two-pole switch can be equipped with its own four-circuit pilot-duty auxiliary contact block, available in any combination

of normally open and normally closed circuits. Dual bifurcated, chisel-point moveable (H-bridge design) contacts of fine silver provide exceptionally high switching reliability and are suitable for low power signals.

The two individual two-pole switches are mechanically interlocked to allow only one switch to be energized at any given time.

Front accessibility to all wear parts eases inspection, maintenance, and repair functions.

Product Listing

Special Purpose – Type 710 Series

Ordering Information

> Catalogue Number as follows:

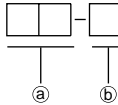
14-193-221- 

- Ⓐ Next two digits specify coil voltage per coil voltage suffix table.
- Ⓑ Last digit specifies auxiliary contact arrangement. For 710 switch, price two auxiliary contacts, (1) for forward and (1) for reverse.

Specifications

Type 710

Main Pole Configuration

Dual Two-Pole, Single Throw (i.e., two independent two-pole power circuits)

Switch Rating

Continuous Current 700 Amps @ 40°C Ambient
Non-Interrupting Switch
Thru Current Capability 15,000 Amps
Special ratings available. Consult factory.

Auxiliary Interlock Rating

Resistance Load
125 VDC or less, 10 Amps
250 VDC, 2.5 Amps

Auxiliary Contact Connections

Two ¼ in. (6.35mm) faston tabs per terminal

Mounting

Mounts on 3 in. (76.2 mm) wide channel support with two ¾ in. (M8) screws

Power Connections

Top and bottom of switch
Two ¾ in.—16 tapped holes per terminal

Coil Connections

Four ¼ in. faston tabs
Two tabs each side of line

Weight

38 lbs. (17.3 kg)

Coil Suffix Table

DC Volts Coil Voltage	Suffix
12	51
28	52
36	55
48	54
74	56
96	57
125	58
250	59

Auxiliary Contacts

Configuration	Code
1 NO & 3 NC	1
2 NO & 2 NC	2
3 NO & 1 NC	3
4 NO & 0 NC	4
0 NO & 4 NC	5
None	7

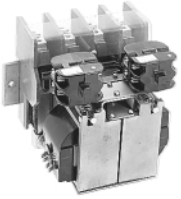
Illustration	Description	Configuration	Rated Voltage	Catalogue No.	Approx. Wt. Lbs (Kg)
<p>Type 710, 1250 Ampere</p>  <p>TYPE 710</p>	Switch (non-interrupting) with mechanical interlock without auxiliary contact	Dual two pole switch (non-interrupting)	1500 V	14-193-120-+-+	38 (17.3)

Operating Coils

Volts DC	Ohms (20°C)
12	4.9
28	20
36	32
48	45
74	125
96	177
110-125	294
250	1160

Coil voltage tolerance 80% to 110% of rated voltage.

Minimum pickup voltage is 60% of rated coil volts, with cold (20°) coil and 80% of rated coil volts with hot (140°) coil. Dropout is from 5% to 25% of rated coil volts. All temperatures in °C.

Outline Drawings

Special Purpose – Type 710

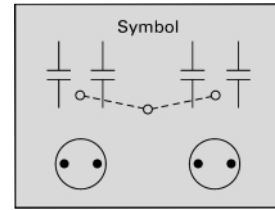

8 - .375 -16 Tapped Holes x .875 Deep Full Thread For Customer's Connections

2 - .250 Faston Tabs Per Terminal For Customer's Connections

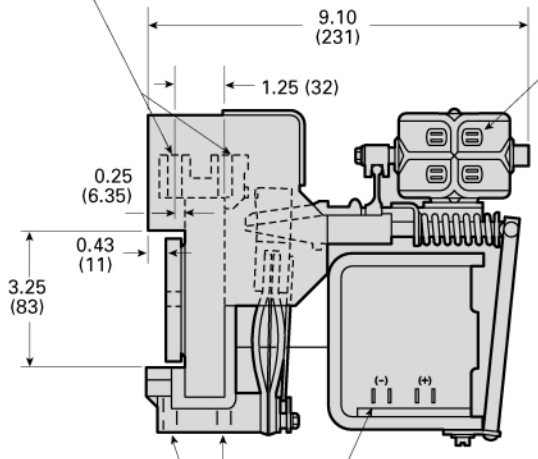

4 - .250 Faston Tabs For Customer's Connection To Each of Two Magnet Coils

8 - .375 - 16 Tapped Holes x .875 Deep Full Thread For Customer's Connections

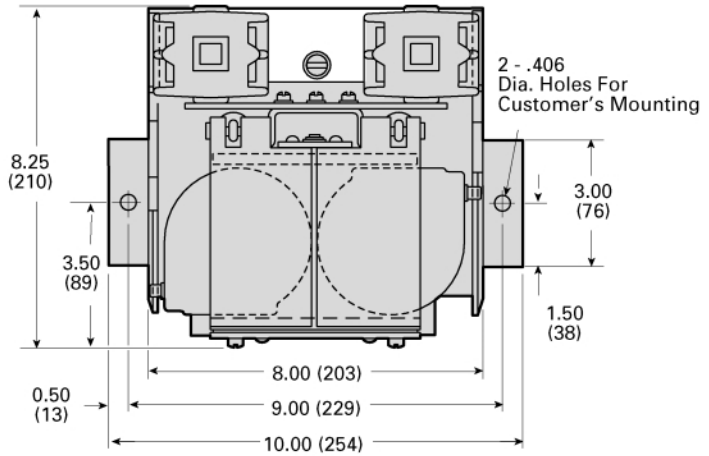

2 - .406 Dia. Holes For Customer's Mounting

All dimensions shown in inches. For reference purposes only. Not to be used for design or construction purposes.



Hubbell Industrial Controls, Inc.

A subsidiary of Hubbell Incorporated

4301 Cheyenne Dr., Archdale, NC 27262

Telephone (336) 434-2800 • Fax (336) 434-2803

<http://www.hubbell-icd.com>

Sales@hubbell-icd.com