



# Single Phase 120VAC & 240VAC Transient Voltage Filters



## Specifications

### Electrical

**Input Voltage:** Up to 240VAC, 1Ø, 50/60Hz.

**Capacitance:** 0.47 microfarads, ±10%

**Resistance:** 22 to 680 ohms, ±10%, 0.5 watt

### Varistors:

Voltage Code	Max. Allowable AC Voltage	Max. Clamping Voltage	Energy (Joules)
1	130VAC	340V @ 10A	10
2	130VAC	340V @ 10A	10
3	250VAC	650V @ 10A	17
7	150VAC	395V @ 25A	25

**Power Consumption:** 10VA @ 240VAC

### Physical

**Termination:** #18 Stranded Wire Leads or #20 Solid Wire Leads

**Packaging:** Epoxy Filled

**Weight:** 1 Oz.

### Ambient Temperatures

**Operating:** -40°C to 85°C

**Storage:** -40°C to 85°C



## Ordering Information

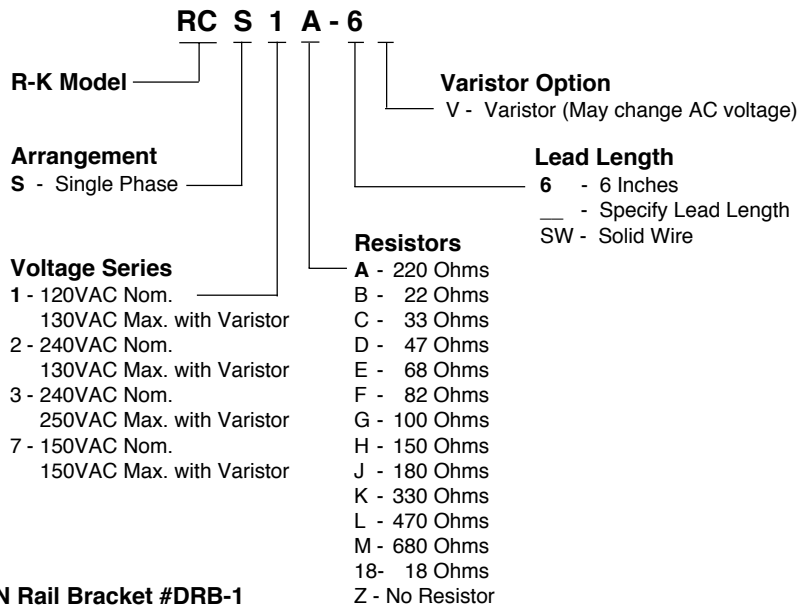

**DIN Rail Bracket #DRB-1**

## Connections

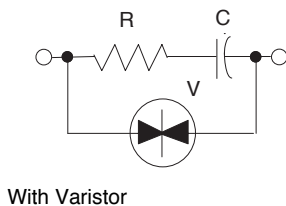
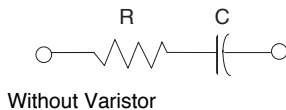

### Hook-Up Example

MS = Motor Starter SV = Solenoid Valve  
C1 = Contact C2 = Contact  
RCS = R-D Network

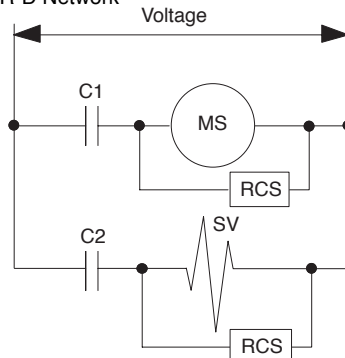

- 120 & 240 Volt Ratings
- Single Phase (1Ø) Applications
- Varistor Options
- Stranded Wire or Solid Wire Leads



## Operation

### Transient Voltage Filters

R-C networks (Resistance-Capacitance) are applied to circuits where transient electrical voltages can cause a malfunction or damage in solid state controls or control systems (PLCs, CNCs, NCs, Solid State Counters, etc.) The RCSs are typically applied in parallel with single phase inductive loads (motor starter coils, contactor coils, solenoid valves, etc.) to absorb the transients generated when the load is de-energized.

## Dimensions

