

FV3 Frequency to Voltage Converter

- Delivers 0 to +10 VDC or 4-20 mA outputs proportional to input pulse rate (frequency).
- Accepts variable pulse rate inputs from a variety of sensors.
- Linearity ±0.2% maximum.
- An FV3 and an encoder replace a DC Tachometer when precision feedback is required.



APPLICATION/INDUSTRY

Dynapar FV3 frequency-to-voltage converter, when used with a Dynapar encoder, converts the frequency output of the encoder to an analog signal for operating chart recorders, or for supplying velocity feedback in closed loop speed control systems.

DESCRIPTION

Dynapar FV3 frequency-to-voltage converter measures a pulse input frequency and converts it to an analog 0 to +10 VDC or 4-20 mA output proportional to machine or process speed. When used with a Dynapar encoder, it converts the frequency content of the encoder to an analog signal for operating chart recorders, or for supplying velocity feedback in closed loop speed control systems.

A wide range of digital pulse transducers, application speed ranges, and converter response times can be configured via jumpers. The FV3 also includes 12 VDC transducer supply power.

FEATURES AND BENEFITS

Electrical Features

- 0 to +10 VDC or 4-20 mA analog output.
- Linearity is typically ±0.1% of full scale.
- Switch selectable 115 or 230 VAC, 50/60 Hz power.
- Jumper selectable input frequency range.
- Built-in transducer power supply.
- Front-mounted terminal strips for field connections.
- Potentiometer adjustments (gain, offset, 20 mA set and 4 mA set).
- Jumper-selectable input circuit to accept signals from a variety of sensors (i.e. sensor outputs with open collector PNP or NPN, line driver, magnetic sinewave, switch contact, etc.)

SPECIFICATIONS

STANDARD OPERATING CHARACTERISTICS

Electrical

Input Power Requirements: 115/230 VAC ±10%, 50/60 Hz; 120 mA @ 115 VAC, 60 mA @ 230 VAC;
Externally fuse with Slo-Blo type 1/8 A for 115 VAC or 1/16 A for 230 VAC
Available Power for the Transducer: 12 VDC ±5%, 75 mA max.
Input Signal: (Field-Selectable) 2.5 to 15V single-ended; or magnetic 1.5 to 15V peak-to-peak
Input Frequency Range: (Adjustable) Unidirectional: 0.03 to 0.1 kHz; 0.1 to 0.3 kHz; 0.3 to 1 kHz; 1-3 kHz; 3-10 kHz; 10-30 kHz; 20-60 kHz
Analog Output: 0 to +10V unidirectional @ 25 mA
Voltage Output Linearity: ±0.1% of full scale
Current Range: 4-20 mA into load resistance range of 0-800 ohms
Current Linearity: ±0.2% max.
Output Overrange: 10% min. (volt. or current)
Output Offset: Adjustable
Speed Detector/Alarm Output (Optional)
This feature monitors transducer speed and can be adjusted—5% to 100%—from a front panel potentiometer to trip at a specific speed. The output is a relay contact, field selectable via an internal jumper as N.O. or N.C. Contact rating is 1.25 Amp AC/DC, 125 Volts.
Environmental
Operating Temperature: 0 to 60°C
Storage Temperature: -18° to +85°C
Relative Humidity: to 90% non-condensing

APPLICATION CONSIDERATIONS

Transducer Selection: The FV3 operates on the frequency content of a sinusoidal, triangular, or square waveform. Typical transducers include:

- 1) A magnetic pick-up detecting a passing keyway, gear teeth, etc.
- 2) A photo eye which scans alternating opaque and transparent slots.
- 3) A digital tachometer or encoder.

For fast response of FV3 outputs, it is important that the transducer be located toward the high speed end of the drive train. For slow shaft speeds, the transducer must be capable of delivering a high number of cycles or pulses per revolution. The transducer should also be capable of delivering a usable output for the entire speed range through maximum speed.

The following formula is convenient for relating machine speeds and sensor frequency output:

$$\text{FRQ (CPS or Hz)} = \frac{\text{RPM} \times \text{PPR}}{60}$$

Where:

RPM is the speed of the shaft where the sensor is located in revolutions per minute.

PPR is the number of pulses (or cycles) produced by the sensor for one shaft revolution.

FV3 Performance: The FV3 range adjustment allows the unit to deliver full-scale output for any input frequency within the limits of each range rating. It will provide a better combination of fast response and low ripple when input frequencies for full scale output are at least 3 kHz and above. The FV3 is provided with the capability for field-installed capacitance to optimize response time vs. ripple if required (see the technical manual).

Full-Scale Range Adjustment ¹		Response Time ²
Min.	Max.	
30 Hz	100 hz	5.1 sec.
100 Hz	300 hz	1.7 sec.
300 Hz	1 kHz	0.52 sec.
1 kHz	3 kHz	13 msec.
3 kHz	10 kHz	10 msec.
10 kHz	30 kHz	6 msec.
20 kHz	60 kHz	6 msec.

¹Field-selectable range adjustment via jumpers (refer to technical manual).

²Response time is time required for the output to reach 99% of final value when the input frequency instantly changes from 0 to full scale.

Typical Application

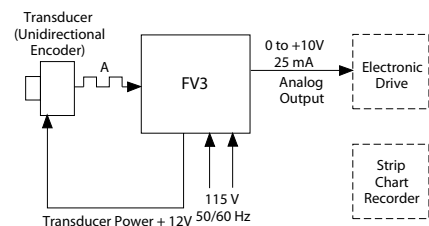

Unidirectional with 0 to +10V output

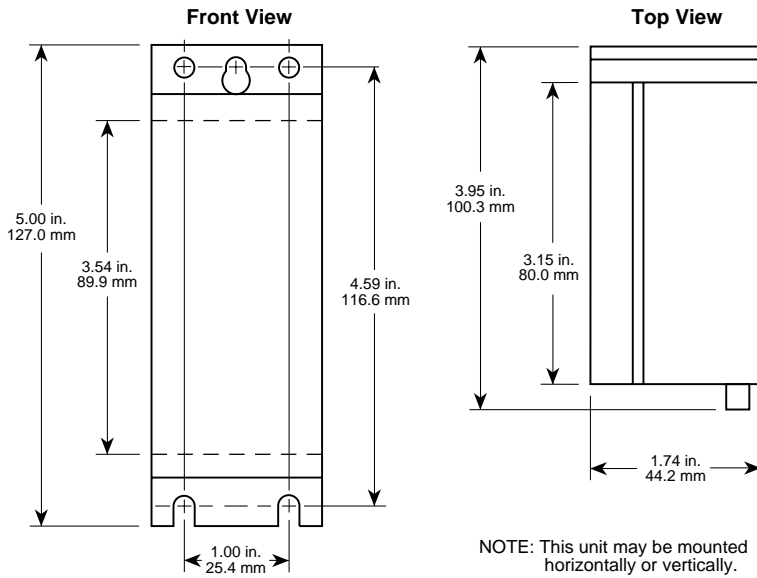

Mounting Dimensions (inches/mm)



Electrical Connections

FV3-0 Functions		Terminal
Power Input	115/230 VAC	L1
	115 Neutral/230 VAC	N/L2
	Case Ground	GND
Transducer Input & Supply	Encoder Supply V+	1
	Encoder Supply Common	2
	Signal A or Magnetic	3
Speed Detector Output (Optional)	 *	4
	 or 	5
Analog Outputs	4-20 mA	6
	Common	7
	+10V	8

*Circuit is field selectable as normally open or normally closed output, via internal jumper selection.

Ordering Information

Model No.	Description
FV3-0-S-00	Frequency-to-Voltage Converter
FV3-1-S-00	Frequency-to-Voltage Converter with Speed Detection Option
845-26*	Technical Manual

*A technical manual is automatically shipped with each FV3. Use this publication number to order extra copies.