



Product Selector

	• Index, table of contents, alphanumeric	0
Industrial controls	1. Contactors	1
	2. Overload relays	2
	3. Starters	3
	4. Miniature control	4
	5. Manual motor protectors	5
	6. Softstarters & electronic brakes	6
	7. Relays	7
	8. Pilot devices	8
	9. Limit switches	9
	10. Sensors	10
	11. Cam switches	11
	12. Transformers	12
	13. Cable management systems	13
Circuit Protective Devices	14. Modular DIN rail products	14
	15. Molded case circuit breakers	15
	16. Low voltage power breakers	16
	17. Disconnect switches	17
	18. Arc Guard Systems	18
LVNQ	19. LVNQ capacitors	19
Systems	20. MCCs, smissline	20

This catalog is published for information purposes only and is not all inclusive. For additional information on products or technical information, consult ABB Inc. The installation and use of ABB Inc. products should be in accordance with the provisions of the U.S. National Electrical Code and/or other local codes or industry standards that are pertinent to the particular end use. Installation or use not in accordance with these codes and standards could be hazardous to personnel and/or equipment.

Industrial controls

Contactors



1 - Contactors

Across the Line 1.1 – 1.96

Accessories for A/AE/AL/AF	1.25 - 1.30
Accessory combinations.....	1.18
Arc chutes for A/AE/AL/AF	1.29
Auxiliary contact blocks for A/AF/AL & AE.....	1.16
Auxiliary lead terminals	1.17
Capacitor switching for UA26 - UA110	1.15
Coils.....	1.26 - 1.27
Connection bars for A/AE/AF	1.30
Connection kits for A/AE/AL/AF	1.28
Contact kits for A/AE/AL/AF	1.25
Contactors	1.3 - 1.15
Contactors, mechanically interlocked.....	1.3 - 1.12
Contactors, NEMA rated.....	1.11 - 1.12
Contactors, reversing	1.3 - 1.12
Description, A9 - AF1650.....	1.1
Dimensions.....	1.83 - 1.86
Electronic timer for wye-delta starters	1.31 - 1.32
Four pole contactors.....	1.13 - 1.14
Identification markers, A/AE/AL/AF	1.25
Interface relays for A contactors	1.23 - 1.24
Interlocks, A9 - AF750	1.17
Lead terminals, auxiliary	1.17
Lug kits, terminal for A/AE/AL/AF	1.25
Mechanical latches for A/AE/AL/AF	1.25
Mechanically interlocked contactors.....	1.3 - 1.12
Motor data	1.82
NEMA rated contactors	1.11 - 1.12
Pneumatic timers for A/AF/AL & AE	1.17
Reversing contactors.....	1.3 - 1.12
Ring tongue terminated contactors	1.10
Shorting bars for A/AE/AF	1.30
Surge suppressors for A/AE/AL/EK	1.21 - 1.22
Technical data	1.36 - 1.82
Terminal blocks & access. for A/AE/AL/AF	1.29
Terminal lug kits for A/AE/AL/AF	1.25
Terminals, auxiliary lead	1.17
Timers, electronic, for wye delta starters.....	1.31 - 1.32
Timers, pneumatic for A/AF/AL & AE.....	1.17

Definite purpose contactors..... 1.97 – 1.104

Auxiliary contact blocks	1.98
Contactors, 30A - 60A	1.98
Description	1.97
Dimensions.....	1.100 - 1.103
Technical data	1.99

Drive contactors 1.105 – 1.114

Auxiliary contacts blocks	1.106
Coils for EHDB	1.107
Contact kits.....	1.110
Contactors, 2 & 3 pole.....	1.106 - 1.107
Contactors, mechanically interlocked.....	1.108
Description	1.105
Dimensions.....	1.113 - 1.114
Lug kits	1.110
N.C. DB kit only	1.110
Replacement parts	1.109 - 1.110
Technical data	1.111 - 1.112

Welding contactors 1.115 – 1.120

Connection bars	1.116
Contactors	1.116
Description	1.115
Dimensions.....	1.118 - 1.119
Technical data	1.117

AC Switching contactors 1.121 – 1.124

Contactors	1.122
Description	1.121
Surge suppressors	1.123
Technical data	1.124

DC Switching contactors 1.125 – 1.128

Contactors	1.126
Description	1.125
Dimensions.....	1.127

Bar contactors 1.129 – 1.130

Description	1.129
Specification checklist	1.130

Industrial controls

Overload relays

Starters

2 - Overload relays

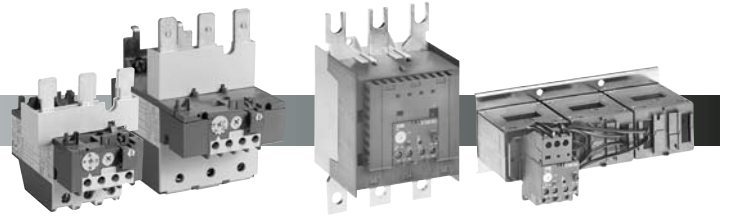

Thermal overload relays 2.1 – 2.18

Accessories	2.7 - 2.8
Description	2.1 - 2.3
Dimensions.....	2.15 - 2.17
Lug kits	2.7
Mounting kits	2.7
Overload relays, Type TA	2.6
Remote tripping coils	2.8
Selection guide	2.4 - 2.5
Technical data	2.9 - 2.14
Terminal blocks & accessories	2.7

Electronic overload relays..... 2.19 – 2.28

Accessories	2.22
Dimensions.....	2.27 - 2.28
General information.....	2.19 - 2.20
Lug kits	2.22
Mounting kits	2.22
Overload relays	2.21
Technical data	2.23 - 2.26
Terminal shrouds	2.22

3 - Starters



General information 3.1 – 3.10

Catalog number explanation	3.4
Electronic overload relays	3.7
Enclosures.....	3.8 - 3.9
Factory modification kits	3.3
Field modification kits	3.2
IP Environmental ratings	3.10
Motor data	3.5
Standard thermal overload relays	3.6

Across the line starters 3.11 – 3.46

Dimensions.....	3.25 - 3.26
General information.....	3.11
Non-reversing.....	3.14 - 3.17
Plastic enclosed, IP65	3.24
Reversing	3.18 - 3.19
Starter selection by HP	3.12 - 3.13
Two speed, one winding	3.20 - 3.21
Two speed, two winding	3.22 - 3.23

Combination starters 3.47 – 3.70

General information.....	3.47 - 3.48
Factory modifications	3.49
Non-fusible disconnect switch type	3.50 - 3.51
Fusible disconnect switch type	3.52 - 3.55
Circuit breaker type	3.56 - 3.62
Dimensions.....	3.64 - 3.70

Reduced voltage starters 3.71 – 3.91

General information.....	3.71 - 3.72
Factory modifications	3.73
Auto-transformer	3.74 - 3.75
Wye-delta	3.76 - 3.79
Part winding.....	3.80 - 3.81
Circuit diagrams	3.82 - 3.83
Dimensions.....	3.84 - 3.91

Industrial controls

Miniature controls

Manual motor protectors

4 - Miniature controls

General information	4.1
Miniature contactors	4.2 – 4.20
Accessories	4.11 - 4.12
Auxiliary contact blocks	4.11
Contactors	4.2
Contactors for connection to PLCs	4.5
Dimensions	4.19 - 4.20
Identification labels	4.11
Interface contactors	4.4
Mechanically interlocked contactors	4.3
Plunger	4.11
Protective cover	4.12
Reversing connection link	4.12
Soldering connection	4.11
Surge suppressors	4.12
Technical data	4.13 - 4.14
Miniature overload relays	4.6
Dimensions	4.19
Overload relays	4.6
Technical data	4.18



Miniature starters	4.7 - 4.8
Dimensions	4.19
Starters	4.7 - 4.8
Miniature relays	4.9 - 4.20
Control relays	4.9
Dimensions	4.20
Interface relays	4.10
Technical data	4.14 - 4.17

5 - Manual motor protectors

General information	5.1 - 5.2
MS116	5.3 - 5.9
Accessories	5.4 - 5.5
Auxiliary contact blocks	5.4
Bell alarm contacts	5.4
Busbars	5.5
Dimensions	5.8 - 5.9
Door mounting hardware	5.5
Enclosures	5.4
Locking devices	5.4
MS116 Manual motor protectors	5.3
Power feed terminals	5.5
Shunt trip	5.4
Technical data	5.6 - 5.7
Undervoltage trip	5.4
MS325	5.10 - 5.27
Accessories	5.11 - 5.12
Auxiliary contact blocks	5.11
Bell alarm contact blocks	5.11
Busbars	5.12
Close coupling adapters	5.12
Dimensions	5.25 - 5.27
DLA starters	5.13
Enclosures	5.12
MS325 manual motor protectors	5.10
Padlocking devices	5.11
Power feed terminal blocks	5.12
Remote control unit	5.11
Shunt trips	5.11
Supporting terminal	5.11
Technical data	5.19 - 5.22
Undervoltage trip	5.11
WLA starters	5.14



MS450 & MS497	5.15 - 5.28
Accessories	5.17 - 5.18
Auxiliary contacts	5.17
Auxiliary release	5.17
Close coupling adapters	5.17
Dimensions	5.28
FLA adjustment cover	5.18
MS450 - 497 Manual motor protectors	5.15 - 5.16
Power feed terminal block	5.17
Selector handles	5.18
Signalling contact	5.18
Technical data	5.23
Terminal	5.18
Terminal shrouds	5.18

6 - Softstarters



Type PSS Softstarters 6.1 - 6.20

Accessories 6.8
 Auxiliary contact blocks 6.8
 Auxiliary relays 6.8
 Circuit diagrams 6.11 - 6.15
 Control & current transformers 6.8
 Dimensions 6.16 - 6.19
 General information 6.1 - 6.2
 Lug kits 6.8
 Meters & metering 6.8
 PSS Softstarters, enclosed 6.5 - 6.7
 PSS Softstarters, open 6.3 - 6.4
 Softstarter accessories 6.8
 Technical data 6.9 - 6.10
 Terminal blocks 6.8
 Terminal covers 6.8

Type PST Softstarters 6.21 - 6.48

Accessories 6.31 - 6.34
 Auxiliary contact blocks 6.32
 Auxiliary relays 6.32
 Circuit diagrams 6.39 - 6.42
 Control transformers 6.31
 DeviceNet communication accessories 6.33
 Dimensions 6.43 - 6.48
 General information 6.21 - 6.24
 Lug kits 6.31
 Meters & metering 6.32

Profibus DP communication accessories 6.34
 PST Softstarters, enclosed 6.26 - 6.30
 PST Softstarters, open 6.25
 Softstarter accessories 6.32
 Technical data 6.35 - 6.38
 Terminals 6.31

Type SSM Softstarters 6.49 - 6.54

Dimensions 6.53
 General information 6.49 - 6.50
 SSM Softstarters 6.51
 Technical data 6.52

Type PEB Electronic brakes 6.55 - 6.62

Circuit diagrams 6.60 - 6.61
 Dimensions 6.60 - 6.61
 General information 6.55 - 6.56
 Power electronic brakes, enclosed 6.58
 Power electronic brakes, open 6.57
 Technical data 6.59

7 - Relays

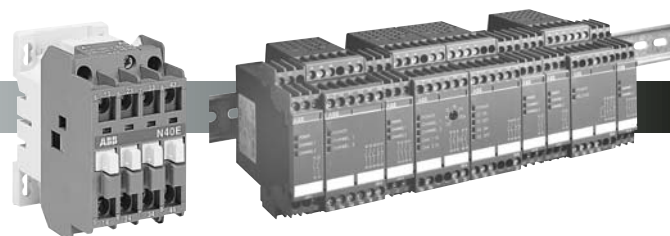

Control relays 7.1 - 7.18

Accessories 7.7 - 7.11
 Accessory mounting information 7.9
 Auxiliary contact blocks 7.7
 Coils 7.8
 Control relays, Type N & NL 7.5 - 7.6
 Dimensions 7.17 - 7.18
 General information 7.1 - 7.4
 Identification markers 7.7
 Interlocks 7.7
 Mechanical latches 7.7
 Pneumatic timers 7.7
 Possible accessory combinations 7.9
 Surge suppressors 7.8
 Technical data 7.11 - 7.16

Electronic safety relays 7.19 - 7.50

Accessories, C570-C579 7.3
 Application examples, C6700-C6702 7.34 - 7.37
 Application examples, C570-C579 7.41 - 7.48
 C565 - C6702 7.31 - 7.32
 C570 - C579 7.20 - 7.29
 Cover cap 7.3
 Dimensions 7.49
 General information 7.19
 Panel mounting bracket 7.3
 Personnel & machine protection 7.38 - 7.39
 Selection table 7.4
 Technical data 7.33

8 - Pilot devices

Compact pilot devices 8.1 - 8.8

Accessories	8.5 - 8.6
Adaptors, 30mm	8.6
Bulbs	8.5
Dimensions	8.8
General information	8.1
Lamp changing tool	8.6
Legend plates	8.6
Mounting tool	8.6
Non-illuminated	8.2 - 8.4
Pilot lights	8.4
Protective membrane	8.6
Pushbuttons	8.2
Selector switches	8.3
Technical data	8.7

Type CBK 22mm pilot devices 8.9 - 8.62

Non-illuminated	8.9 - 8.24
Buzzer	8.23
Emergency stop	8.17
General information	8.9 - 8.13
Illuminated	8.25 - 8.39
Key operated	8.19
Key operated selector switch	8.24
Mushrooms	8.16
Non-illuminated	8.9 - 8.24
Potentiometer	8.23
Pushbuttons	8.14 - 8.15
Reset actuator	8.23
Selector switches	8.21 - 8.22
Toggle switches	8.20
Two button	8.18
Illuminated	8.25 - 8.39
Emergency stop	8.31 - 8.32
Mushrooms	8.29 - 8.30
Pilot lights	8.39
Press to test	8.35
Pushbuttons	8.25 - 8.28
Selector switches	8.36 - 8.38
Two button pushbuttons	8.33 - 8.34
Components	8.40 - 8.53
Accessories	8.50 - 8.51
Adaptor rings	8.49
Bezel, square	8.50
Boots, flush & extended	8.50
Button guard	8.50
Buttons	8.48
Components	8.40 - 8.53
Contact blocks	8.4 - 8.5
DIN rail mounting kit	8.51
Diode block	8.42
Enclosures, plastic	8.52 - 8.53
Front cap	8.51
Gasket, spare	8.50
Grounding screw	8.51
Hole plug, 22mm	8.50
Key, extra	8.50
Lamp modules	8.42
Lamp removal tool	8.50
Lens inserts	8.43 - 8.44
Lenses	8.48
Mounting rings	8.49

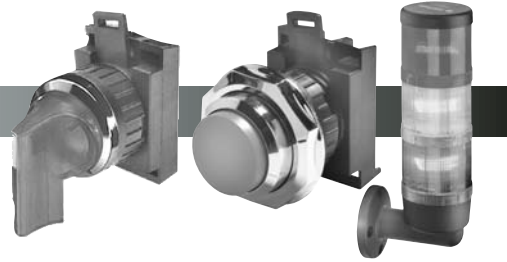

Mounting tool	8.50
Mushroom guard	8.50
Nameplates	8.45 - 8.47
Padlock attachment	8.50
Protective cover	8.50
Selector switch guard	8.50
Selector switch lock	8.50
Snap connector	8.51
Transformers	8.42
Technical data	8.54 - 8.56
Dimensions	8.57 - 8.62

Type CBG 30mm pilot devices 8.63 - 8.100

Non-illuminated	8.64 - 8.73
Emergency stop	8.67
General information	8.63
Key operated	8.68
Mushrooms	8.66
Potentiometers	8.73
Pushbuttons	8.64 - 8.65
Reset actuator	8.73
Selector switches	8.70 - 8.72
Toggle switches	8.69
Illuminated	8.74 - 8.87
Emergency stop	8.78 - 8.81
Mushrooms	8.76 - 8.77
Pilot lights	8.86 - 8.87
Press to test	8.85
Pushbuttons	8.74 - 8.75
Selector switches	8.82 - 8.84
Components	8.88 - 8.93
Contact blocks	8.88
Diode block	8.89
Enclosure standards comparison	8.94
Lamp modules	8.89
Lens inserts	8.90 - 8.91
Nameplates	8.92 - 8.93
Transformers	8.89
Technical data	8.95 - 8.96
Dimensions	8.97 - 8.99

Stacklights & signal beacons 8.101 - 8.110

Accessories, stacklights	8.103
Audible modules	8.103
Dimensions	8.108 - 8.109
General information	8.101
Parts	8.103
Signal beacons	8.104
Stacklights	8.102
Technical data	8.105 - 8.107
Terminal elements	8.103

Industrial controls

Limit switches, Sensors

Cam switches

9 - Limit switches

Plastic casing limit switches	9.1 - 9.30
Assembled, 30mm	9.6 - 9.9
Assembled, 40mm	9.14 - 9.18
Components, 30mm	9.10 - 9.13
Components, 40mm	9.19 - 9.24
General information	9.1
General information	9.4 - 9.5
Selection guide	9.2 - 9.3
Technical data	9.25 - 9.30
Metal casing limit switches	9.31 - 9.60
Assembled, 40mm	9.36 - 9.41
Assembled, 60mm	9.48 - 9.53
Components, 40mm	9.42 - 9.47
Components, 60mm	9.54 - 9.59
Description	9.34 - 9.35
General information	9.31
Selection guide	9.32 - 9.33
Technical data	9.60



Safety limit switches	9.61 - 9.100
General information	9.61
Latch & manual reset	9.89 - 9.100
Latch key	9.67 - 9.76
Rotative axis	9.77 - 9.88
Selection guide	9.62 - 9.65
Foot switches	9.101 - 9.108
Components	9.105
Dimensions	9.107 - 9.108
Foot switches	9.103 - 9.104
General information	9.101 - 9.102
Technical data	9.106 - 9.108

10 - Sensors

General information	10.1 - 10.8
General information	10.1
Selection guide, Photoelectric	10.6 - 10.7
Selection guide, Proximity	10.2 - 10.5
Selection guide, Ultrasonic	10.8
Proximity sensors	10.9 - 10.82
Capacitive	10.81 - 10.82
General information	10.9 - 10.10
Inductive	10.11 - 10.80
Photoelectric sensors	10.83 - 10.110
Diffused	10.89 - 10.93
General information	10.83 - 10.88
Retro-reflective	10.94 - 10.97



Ultrasonic sensors	10.111 - 10.120
Analog output	10.117 - 10.118
Discrete output	10.114 - 10.116
General information	10.111 - 10.113
Technical data	10.119 - 10.120

11 - Cam switches

Cam switches	11.1 - 11.24
2 position	11.2 - 11.3
3 position	11.4 - 11.5
4 position	11.6
5 position	11.7
6 position	11.8
7 position	11.9
Accessories	11.10
Circuit diagrams	11.14 - 11.20
Contact plans	11.21 - 11.23
Dimensions	11.13
General information	11.1
Technical data	11.11 - 11.12



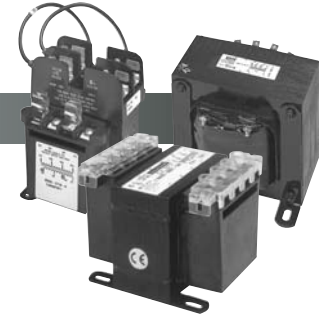

12 - Transformers

Transformers	12.1 - 12.12
General information	12.1 - 12.4
Technical data	12.10 - 12.11
Transformers	12.3 - 12.6
Transformers with CE Mark	12.7 - 12.9

13 - Cable management systems

General information	13.1 - 13.2
Wiring duct & spiral wrap	13.1 - 13.2
General information	13.3
Wiring duct	13.4 - 13.6
Spiral wrap	13.6
Tools & accessories	13.7 - 13.9
Rivets	13.7
Wire stops	13.7
Rapid clip for DIN rail	13.7
Hand cutting tool	13.7
Rivet gun	13.7
Adhesive tape	13.7
Wiring duct covers	13.7
Wiring duct cutter	13.8 - 13.9
Technical data	13.10 - 13.13
Dimensions	13.14

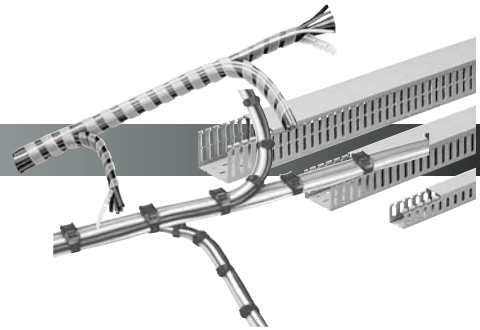

Cable ties	13.15 - 13.20
Accessories	13.17
Cable tie cutter	13.17
Cable ties	13.16
Dimensions	13.18 - 13.20
General information	13.15
Outer cable tie cutter	13.17
Push in base	13.17
Screw mounted base	13.17
Self adhesive tape	13.17
Technical data	13.18 - 13.19

Circuit protective devices

Pro M Modular DIN rail products

Molded case circuit breakers

14 - Pro M Modular DIN rail products

S260 - S290 Miniature circuit breakers..... 14.1 - 14.32

Accessories	14.15 - 14.20
Auxiliary contacts	14.18
Bell alarm	14.18
Blanking plates	14.19
Busbars, S260-S280	14.15 - 14.17
Connection terminals.....	14.20
Cross reference	14.31
Dimensions.....	14.28 - 14.30
Enclosure, IP55	14.19
Front mounting bracket	14.19
Front mounting clip	14.19
Front mounting kit.....	14.19
General information.....	14.4 - 14.5
Hand operated neutral disconnect	14.18
Handle mechanism.....	14.19
Labeling accessory.....	14.19
Locking device.....	14.19
Mounting rail.....	14.19
Posidrive tools	14.20
S260 - S290	14.6 - 14.14
Shunt trip	14.18
Technical data	14.21 - 14.27
Terminal cover enclosure, IP40	14.19
Undervoltage release	14.18

S280U Molded case circuit breakers 14.33 - 14.36

Dimensions.....	14.36
General information.....	14.33
S280U MCCBs	14.34
Technical data	14.35

15 - Molded case circuit breakers

Isomax MCCBs 15.1 - 15.128

Accessories	15.54 - 15.64
Auxiliary contacts, S1 - S7	15.56
Cable lug kits, S3 - S7	15.58
Cable termination kits, S1 - S7	15.63
Circuit diagrams	15.72 - 15.82
Dimensions.....	15.83 - 15.128
DIN rail mounting kits, S1 - S7	15.62
Door interlock bracket, S1 - S7	15.62
Draw-out crank, S1 - S7	15.63
Enclosures.....	15.65 - 15.70
Flange handle operators, S1 - S7	15.60 - 15.61
Front locking device, S1 - S7	15.62
General information.....	15.1 - 15.12
Hand-held test kit, S1 - S7	15.63
Key locks, S1 - S7	15.62
Mechanical interlock plates, S1 - S7	15.62
Motor operators, S3 - S7	15.57
Protective releases	15.13 - 15.28
Rear connected stud kits, S1 - S7	15.63
Rotary handle mechs., S1 - S7	15.59
S1 - S8 Isomax MCCBs	15.29 - 15.53

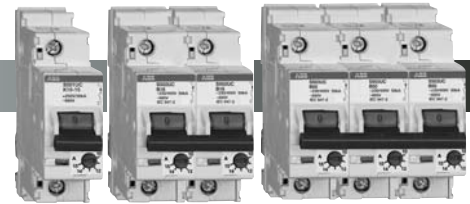

S500 Miniature circuit breakers 14.37 - 14.44

Accessories	14.42
Auxiliary contacts	14.42
Bell alarm	14.42
Busbars	14.42
Dimensions.....	14.44
Front mounting kit.....	14.42
General information.....	14.37
Handle mechanism.....	14.42
Power feed terminal	14.42
S500	14.38 - 14.41
Shunt trip	14.42
Technical data	14.43
Undervoltage release	14.42

F370, F670 Residual current devices 14.45 - 14.48

Circuit diagrams	14.47
Dimensions.....	14.47
F370-F674 RCDs	14.46
General information.....	14.45

E220 - E270 Modular DIN rail components 14.49 - 14.54

Dimensions.....	14.54
Disconnect switches, E241 - E274.....	14.51
General information	14.49
Pilot devices, E225 - E229	14.52
Switches, E221 & E222.....	14.50
Technical data	14.53

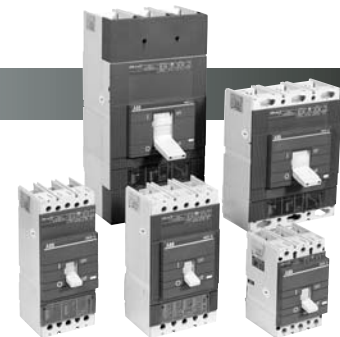

Shunt trips, S1	15.54
Shunt trips, S3 - S7	15.55
Technical data	15.71
Terminal covers, S1 - S7	15.62
Undervoltage releases, S1	15.54
Undervoltage releases, S3 - S7	15.55
Variable depth rotary handles, S1 - S7.....	15.59

Circuit protective devices

Molded case circuit breakers, Power breakers

Disconnect switches

15 - Molded case circuit breakers, cont.

Tmax MCCBs	15.129 - 15.146
Accessories	15.138 - 15.140
Auxiliary contacts	15.138
Dimensions	15.145 - 15.146
DIN rail mounting kits	15.140
General information	15.129 - 15.131
Locking device	15.139
Lugs	15.139
Motor operators	15.138
Plug in kits, T2 & T3	15.140
Rear terminals	15.139
Rotary operator handles	15.139
Shunt trips	15.138
Sliding bar interlock	15.140
T1 - T3, Tmax	15.132 - 15.137
Technical data	15.141 - 15.144
Terminal covers	15.140
Undervoltage releases	15.138

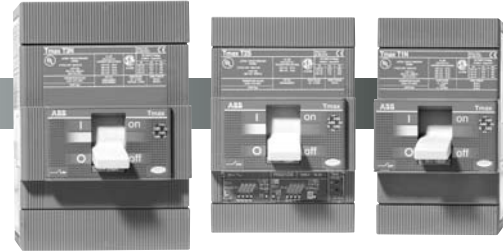

16 - Power breakers

Emax power breakers	16.1 - 16.64
Accessories	16.29 - 16.31
Air circuit breakers	16.26 - 16.28
Current transformers	16.29
Electronic time delay	16.31
Emax breakers, IEC	16.18 - 16.25
Emax breakers, UL	16.6 - 16.13
General information, IEC	16.14 - 16.17
General information, UL	16.1 - 16.5
Mechanical interlocks	16.30
Spare parts	16.31
Test kits	16.31
Transparent front cover	16.31



17 - Disconnect switches

Non-fusible disconnect switches	17.1 - 17.74
Dimensions	17.54 - 17.74
General information	17.1 - 17.7
Kits	17.8 - 17.9
Maintenance bypass switches	17.37 - 17.38
Motor operators	17.39
Other configurations	17.35 - 17.36
Technical data	17.40 - 17.53
Type OETL, 200A - 3150A	17.23 - 17.34
Type OT, 16A - 125A	17.10 - 17.22
Fusible disconnect switches	17.75 - 17.124
Dimensions	17.115 - 17.124
Fuse monitors	17.104
General information	17.75 - 17.81
Kits	17.82
Motor operators	17.105
Other configurations	17.96 - 17.103
Technical data	17.107 - 17.114
Type OESA, 200A - 800A	17.91 - 17.95
Type OS, 30A - 100A	17.83 - 17.90

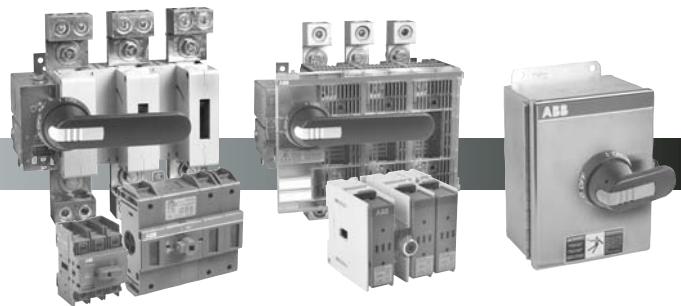

Enclosed disconnect switches	17.125 - 17.152
Dimensions, fusible	17.150 - 17.151
Dimensions, non-fusible	17.141 - 17.142
Enclosed, fusible	17.140 - 17.145
Enclosed, non-fusible	17.130 - 17.142
General information	17.125 - 17.129
Technical data, fusible	17.149
Technical data, non-fusible	17.140

Circuit protective devices

Arc Guard Systems

18 - Arc Guard Systems



Arc Guard Systems	18.1 - 18.12
Arc monitor	18.2
Circuit diagrams	18.5 - 18.10
Current sensing unit	18.2
Detectors	18.2
Dimensions	18.11
Flush mounting set	18.2
General description	18.3 - 18.5
General information	18.1
Mounting bracket	18.2
Optical fiber cable	18.2
Technical data	18.6 - 18.7

Low Voltage Network Quality

19 - Low Voltage Network Quality

General information 19.1 - 19.6

General information	19.2 - 19.4
Options for correcting power factor	19.4
Sizing capacitors	19.5 - 19.6

Individual units & fixed capacitor banks..... 19.7 - 19.26

Dimensions, fixed capacitor banks	19.25 - 19.26
Dimensions, individual capacitors	19.18 - 19.20
Fixed capacitor banks	19.21 - 19.24
General description	19.7 - 19.8
Individual capacitors	19.9 - 19.17

AutoBank 300 & 1200..... 19.27 - 19.34

AutoBank 1200	19.30
AutoBank 300	19.29
Dimensions	19.31 - 19.33
Factory modifications	19.31
General description	19.27 - 19.28

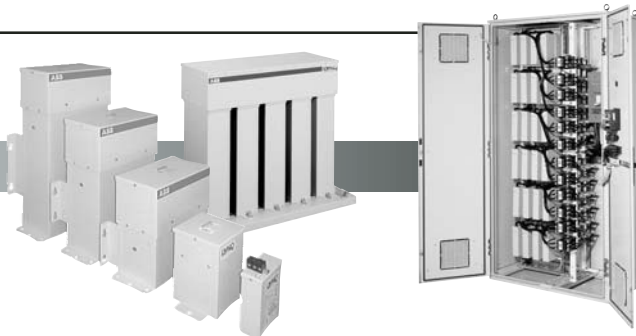

20 - Systems

Panels, MCCs, Distribution systems 20.1 - 20.2

General information 20.1 - 20.2

smisline modular bus system 20.3 - 20.14

Applications with other ABB products 20.9 - 20.12

Bus bar 20.5

Bus covers 20.7

Bus divider 20.7

Bus stab adaptor 20.5 - 20.6

Components 20.4 - 20.9

Dimensions 20.13 - 20.14

End stops 20.5

General information 20.3

Ground terminals 20.8

Labels 20.8

Neutral and ground bus covers 20.8

Neutral and ground sockets 20.8

Neutral terminals 20.8

Sockets 20.5

Starter kits 20.4

Technical data 20.13

Terminals 20.5

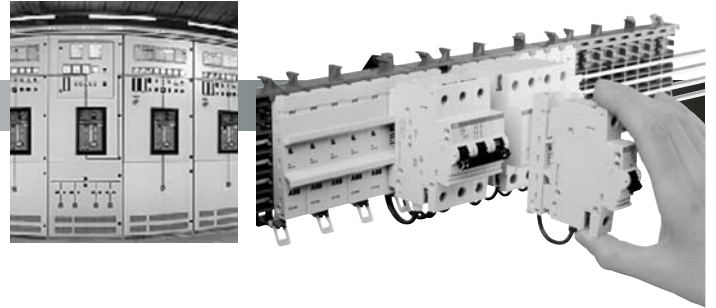

0A1G01 – 1SL5187A00

Catalog number	List price	Discount schedule	Page number	Catalog number	List price	Discount schedule	Page number	Catalog number	List price	Discount schedule	Page number
0A1G01	\$ 20.00	H6	17.12	18251	\$ 18.00	G2	13.17	1SAR533241R0002	\$ 675.00	AR	7.24
0A1G10	\$ 20.00	H6	17.12	18252	\$ 14.00	G2	13.17	1SAR533241R0003	\$ 675.00	AR	7.24
0A2G11	\$ 40.00	H6	17.12	18253	\$ 14.00	G2	13.17	1SAR533241R0004	\$ 675.00	AR	7.24
0A3G01	\$ 20.00	H6	17.12	18270	\$ 150.00	G2	13.17	1SAR533241R0005	\$ 675.00	AR	7.24
0A7G10	\$ 20.00	H6	17.12	18280	\$ 13.00	G2	13.17	1SAR543320R0003	-	AR	7.32
12402	\$ 32.00	CB8	14.19	18282	\$ 20.00	G2	13.17	1SDA038092R1	\$ 122.00	EX	16.31
12404	\$ 45.00	CB8	14.19	18290	\$ 80.00	G2	13.17	1SDA038093R1	\$ 224.00	EX	16.31
12406	\$ 56.00	CB8	14.19	18370	\$ 60.00	G	13.6	1SDA038096R1	\$ 153.00	EX	16.31
12408	\$ 66.00	CB8	14.19	18372	\$ 40.75	G	13.6	1SDA038328R1	\$ 946.00	EX	16.31
12644	\$ 84.00	CB8	5.4	18374	\$ 56.50	G	13.6	1SDA038339R1	\$ 244.00	EX	16.31
12646	\$ 98.00	CB8	5.4	18376	\$ 92.00	G	13.6	1SDA038342R1	\$ 722.00	EX	16.31
12650	\$ 126.00	CB8	14.19	18380	\$ 70.00	G	13.6	1SDA038362R1	\$ 793.00	EX	16.31
12652	\$ 210.00	CB8	14.19	18382	\$ 52.50	G	13.6	1SDA045724R1	\$ 61.00	EX	16.31
18010	\$ 6.50	G2	13.16	18384	\$ 84.00	G	13.6	1SL5019A00	\$ 345.00	G	13.5
18011	\$ 7.00	G2	13.16	18386	\$ 117.25	G	13.6	1SL5033A00	\$ 565.50	G	13.5
18012	\$ 8.00	G2	13.16	1SAR330030R0000	\$ 129.00	AR	7.31	1SL5035A00	\$ 500.00	G	13.5
18013	\$ 8.00	G2	13.16	1SAR390000R1000	\$ 30.00	AR	7.31	1SL5037A00	\$ 734.50	G	13.5
18014	\$ 9.00	G2	13.16	1SAR390000R2000	\$ 22.00	AR	7.31	1SL5043A00	\$ 570.00	G	13.5
18015	\$ 10.25	G2	13.16	1SAR390000R4000	\$ 42.00	AR	7.31	1SL5045A00	\$ 397.50	G	13.5
18017	\$ 12.00	G2	13.16	1SAR501020R0001	\$ 280.00	AR	7.21	1SL5047A00	\$ 590.00	G	13.5
18018	\$ 19.00	G2	13.16	1SAR501020R0003	\$ 280.00	AR	7.21	1SL5049A00	\$ 604.00	G	13.5
18020	\$ 23.00	G2	13.16	1SAR501020R0004	\$ 280.00	AR	7.21	1SL5051A00	\$ 474.00	G	13.5
18024	\$ 22.00	G2	13.16	1SAR501020R0005	\$ 280.00	AR	7.21	1SL5053A00	\$ 432.50	G	13.5
18026	\$ 28.00	G2	13.16	1SAR501031R0001	\$ 340.00	AR	7.23	1SL5063A00	\$ 442.00	G	13.5
18028	\$ 34.00	G2	13.16	1SAR501032R0002	\$ 520.00	AR	7.22	1SL5065A00	\$ 319.00	G	13.5
18034	\$ 46.00	G2	13.16	1SAR501032R0003	\$ 520.00	AR	7.22	1SL5067A00	\$ 488.00	G	13.5
18036	\$ 55.00	G2	13.16	1SAR501032R0004	\$ 520.00	AR	7.22	1SL5069A00	\$ 468.00	G	13.5
18038	\$ 75.00	G2	13.16	1SAR501032R0005	\$ 520.00	AR	7.22	1SL5071A00	\$ 430.00	G	13.5
18060	\$ 55.00	G2	13.16	1SAR501042R0002	\$ 870.00	AR	7.20	1SL5073A00	\$ 343.00	G	13.5
18061	\$ 60.00	G2	13.16	1SAR501042R0003	\$ 870.00	AR	7.20	1SL5083A00	\$ 451.50	G	13.5
18062	\$ 70.00	G2	13.16	1SAR501042R0004	\$ 870.00	AR	7.20	1SL5085A00	\$ 634.50	G	13.5
18063	\$ 70.00	G2	13.16	1SAR501042R0005	\$ 870.00	AR	7.20	1SL5087A00	\$ 456.00	G	13.5
18064	\$ 80.00	G2	13.16	1SAR501120R0001	\$ 350.00	AR	7.26	1SL5089A00	\$ 364.00	G	13.5
18110	\$ 6.75	G2	13.16	1SAR501220R0001	\$ 350.00	AR	7.27	1SL5091A00	\$ 394.00	G	13.5
18111	\$ 7.25	G2	13.16	1SAR502040R0001	\$ 390.00	AR	7.29	1SL5093A00	\$ 336.00	G	13.5
18112	\$ 8.25	G2	13.16	1SAR502040R0003	\$ 390.00	AR	7.29	1SL5094A00	\$ 377.50	G	13.5
18113	\$ 8.50	G2	13.16	1SAR502040R0004	\$ 390.00	AR	7.29	1SL5095A00	\$ 567.00	G	13.5
18114	\$ 9.50	G2	13.16	1SAR503041R0002	\$ 675.00	AR	7.24	1SL5096A00	\$ 432.50	G	13.5
18115	\$ 10.75	G2	13.16	1SAR503041R0003	\$ 675.00	AR	7.24	1SL5097A00	\$ 371.00	G	13.5
18117	\$ 13.00	G2	13.16	1SAR503041R0004	\$ 675.00	AR	7.24	1SL5098A00	\$ 236.00	G	13.5
18118	\$ 20.50	G2	13.16	1SAR503041R0005	\$ 675.00	AR	7.24	1SL5099A00	\$ 372.00	G	13.5
18120	\$ 25.00	G2	13.16	1SAR503141R0002	\$ 675.00	AR	7.24	1SL5119A00	\$ 345.00	G	13.5
18124	\$ 24.00	G2	13.16	1SAR503141R0003	\$ 675.00	AR	7.24	1SL5133A00	\$ 565.50	G	13.5
18126	\$ 31.00	G2	13.16	1SAR503141R0004	\$ 675.00	AR	7.24	1SL5135A00	\$ 500.00	G	13.5
18128	\$ 37.00	G2	13.16	1SAR503141R0005	\$ 675.00	AR	7.24	1SL5137A00	\$ 734.50	G	13.5
18134	\$ 48.00	G2	13.16	1SAR504022R0002	\$ 780.00	AR	7.25	1SL5143A00	\$ 570.00	G	13.5
18136	\$ 57.00	G2	13.16	1SAR504022R0003	\$ 780.00	AR	7.25	1SL5145A00	\$ 397.50	G	13.5
18138	\$ 77.00	G2	13.16	1SAR504022R0004	\$ 780.00	AR	7.25	1SL5147A00	\$ 590.00	G	13.5
18160	\$ 57.00	G2	13.16	1SAR504022R0005	\$ 780.00	AR	7.25	1SL5149A00	\$ 604.00	G	13.5
18161	\$ 63.00	G2	13.16	1SAR505031R0002	\$ 910.00	AR	7.28	1SL5151A00	\$ 474.00	G	13.5
18162	\$ 77.00	G2	13.16	1SAR505031R0003	\$ 910.00	AR	7.28	1SL5153A00	\$ 432.50	G	13.5
18163	\$ 77.00	G2	13.16	1SAR505031R0004	\$ 910.00	AR	7.28	1SL5163A00	\$ 442.00	G	13.5
18164	\$ 85.00	G2	13.16	1SAR505031R0005	\$ 910.00	AR	7.28	1SL5165A00	\$ 319.00	G	13.5
18210	\$ 21.00	G2	13.16	1SAR510210R0003	-	AR	7.32	1SL5167A00	\$ 488.00	G	13.5
18212	\$ 24.00	G2	13.16	1SAR511320R0003	-	AR	7.32	1SL5169A00	\$ 468.00	G	13.5
18218	\$ 32.00	G2	13.16	1SAR513320R0003	-	AR	7.32	1SL5171A00	\$ 430.00	G	13.5
18220	\$ 36.00	G2	13.16	1SAR533141R0002	\$ 675.00	AR	7.24	1SL5173A00	\$ 343.00	G	13.5
18222	\$ 42.00	G2	13.16	1SAR533141R0003	\$ 675.00	AR	7.24	1SL5183A00	\$ 451.50	G	13.5
18224	\$ 55.00	G2	13.16	1SAR533141R0004	\$ 675.00	AR	7.24	1SL5185A00	\$ 634.50	G	13.5
18250	\$ 18.00	G2	13.17	1SAR533141R0005	\$ 675.00	AR	7.24	1SL5187A00	\$ 456.00	G	13.5

1SL5189A00 – A110SS3-84*

Alphanumeric

0

Catalog number	List price	Discount schedule	Page number	Catalog number	List price	Discount schedule	Page number	Catalog number	List price	Discount schedule	Page number
1SL5189A00	\$ 364.00	G	13.5	5173	\$ 343.00	G	13.4	A110SA1-84*	\$ 10,694.00	RVAE	3.74
1SL5191A00	\$ 394.00	G	13.5	5183	\$ 451.50	G	13.4	A110SA2-84*	\$ 12,323.00	RVAE	3.75
1SL5193A00	\$ 336.00	G	13.5	5185	\$ 634.50	G	13.4	A110SA3-84*	\$ 12,323.00	RVAE	3.75
1SL5194A00	\$ 377.50	G	13.5	5187	\$ 456.00	G	13.4	A110SA4-84*	\$ 13,388.00	RVAE	3.75
1SL5195A00	\$ 567.00	G	13.5	5189	\$ 364.00	G	13.4	A110SAX-84*	\$ 14,700.00	RVAE	3.75
1SL5196A00	\$ 432.50	G	13.5	5191	\$ 394.00	G	13.4	A110SF1-84-6D	\$ 2,925.00	ACE	3.52
1SL5197A00	\$ 371.00	G	13.5	5193	\$ 336.00	G	13.4	A110SF2-84*6D	\$ 3,818.00	ACE	3.53
1SL5198A00	\$ 236.00	G	13.5	5194	\$ 377.50	G	13.4	A110SF3-84*6D	\$ 3,818.00	ACE	3.52
1SL5199A00	\$ 372.00	G	13.5	5195	\$ 567.00	G	13.4	A110SF4-84*6D	\$ 4,275.00	ACE	3.53
1SL5300A00	\$ 400.00	G	13.7	5196	\$ 432.50	G	13.4	A110SFP-84*6D	\$ 3,550.00	ACE	3.53
1SL5302A00	\$ 144.00	G	13.7	5197	\$ 371.00	G	13.4	A110SFX-84*6D	\$ 5,850.00	ACE	3.53
1SL5304A00	\$ 170.00	G	13.7	5198	\$ 236.00	G	13.4	A110SG-84**	\$ 8,834.00	WDA	3.76
1SL5306A00	\$ 159.00	G	13.7	5199	\$ 372.00	G	13.4	A110SG1-84**	\$ 6,222.00	WDAE	3.76
1SL5308A00	\$ 164.00	G	13.7	5210	\$ 150.00	G	13.7	A110SG2-84**	\$ 10,508.00	WDAE	3.77
1SL5310A00	\$ 576.00	G	13.7	5214	\$ 30.00	G	13.7	A110SG3-84**	\$ 10,508.00	WDAE	3.77
1SL5312A00	\$ 621.00	G	13.7	5216	\$ 36.00	G	13.7	A110SG4-84**	\$ 10,950.00	WDAE	3.77
1SL5314A00	\$ 637.00	G	13.7	5224	\$ 100.00	G	13.7	A110SGX-84**	\$ 13,125.00	WDAE	3.77
5019	\$ 345.00	G	13.4	5226	\$ 125.00	G	13.7	A110SH-84**	\$ 7,142.00	PWA	3.80
5033	\$ 565.50	G	13.4	5228	\$ 150.00	G	13.7	A110SH1-84**	\$ 7,395.00	PWAE	3.80
5035	\$ 500.00	G	13.4	5230	\$ 200.00	G	13.7	A110SH2-84**	\$ 8,745.00	PWAE	3.81
5037	\$ 734.50	G	13.4	5240	\$ 240.00	G	13.7	A110SH3-84**	\$ 8,745.00	PWAE	3.81
5043	\$ 570.00	G	13.4	5250	\$ 100.00	G	13.7	A110SH4-84**	\$ 9,150.00	PWAE	3.81
5045	\$ 397.50	G	13.4	5252	\$ 80.00	G	13.7	A110SHX-84**	\$ 9,900.00	PWAE	3.81
5047	\$ 590.00	G	13.4	5254	\$ 90.00	G	13.7	A110SM1-84***	\$ 2,970.00	ACE	3.56
5049	\$ 604.00	G	13.4	5256	\$ 100.00	G	13.7	A110SM2-84***	\$ 3,870.00	ACE	3.57
5051	\$ 474.00	G	13.4	5258	\$ 105.00	G	13.7	A110SM3-84***	\$ 3,870.00	ACE	3.56
5053	\$ 432.50	G	13.4	5260	\$ 110.00	G	13.7	A110SM4-84***	\$ 4,200.00	ACE	3.57
5063	\$ 442.00	G	13.4	5262	\$ 115.00	G	13.7	A110SM7-84***	\$ 11,370.00	AXE	3.57
5065	\$ 319.00	G	13.4	5265	\$ 150.00	G	13.7	A110SMP-84***	\$ 3,700.00	ACE	3.57
5067	\$ 488.00	G	13.4	5266	\$ 200.00	G	13.7	A110SMX-84***	\$ 6,050.00	ACE	3.57
5069	\$ 468.00	G	13.4	5300	\$ 400.00	G	13.7	A110SN1-84*	\$ 2,865.00	ACE	3.50
5071	\$ 430.00	G	13.4	5302	\$ 144.00	G	13.7	A110SN2-84*	\$ 3,765.00	ACE	3.51
5073	\$ 343.00	G	13.4	5304	\$ 170.00	G	13.7	A110SN3-84*	\$ 3,765.00	ACE	3.50
5083	\$ 451.50	G	13.4	5306	\$ 159.00	G	13.7	A110SN4-84*	\$ 4,163.00	ACE	3.51
5085	\$ 634.50	G	13.4	5308	\$ 164.00	G	13.7	A110SNP-84*	\$ 3,225.00	ACE	3.51
5087	\$ 456.00	G	13.4	5310	\$ 576.00	G	13.7	A110SNX-84*	\$ 5,530.00	ACE	3.51
5089	\$ 364.00	G	13.4	5312	\$ 621.00	G	13.7	A110SP-84*	\$ 1,440.00	AAE	3.15
5091	\$ 394.00	G	13.4	5314	\$ 637.00	G	13.7	A110SR-84*	\$ 1,800.00	AA	3.18
5093	\$ 336.00	G	13.4	5330	\$ 738.00	G	13.6	A110SR1-84*	\$ 2,970.00	AAE	3.18
5094	\$ 377.50	G	13.4	5331	\$ 450.00	G	13.6	A110SR2-84*	\$ 3,630.00	AAE	3.19
5095	\$ 567.00	G	13.4	5400	\$ 1,344.00	G	13.6	A110SR3-84*	\$ 3,630.00	AAE	3.19
5096	\$ 432.50	G	13.4	5402	\$ 1,134.00	G	13.6	A110SR4-84*	\$ 3,900.00	AAE	3.19
5097	\$ 371.00	G	13.4	5405	\$ 1,820.00	G	13.6	A110SRF1-84*6D	\$ 4,290.00	ACE	3.54
5098	\$ 236.00	G	13.4	5410	\$ 1,260.00	G	13.6	A110SRF2-84*6D	\$ 5,183.00	ACE	3.55
5099	\$ 372.00	G	13.4	5415	\$ 1,075.00	G	13.6	A110SRF3-84*6D	\$ 5,183.00	ACE	3.54
5119	\$ 345.00	G	13.4	5420	\$ 1,375.00	G	13.6	A110SRF4-84*6D	\$ 5,550.00	ACE	3.55
5133	\$ 565.50	G	13.4	5425	\$ 1,064.00	G	13.6	A110SRFP-84*6D	\$ 4,600.00	ACE	3.55
5135	\$ 500.00	G	13.4	5930	\$ 65.00	G	13.7	A110SRFX-84*6D	\$ 7,115.00	ACE	3.55
5137	\$ 734.50	G	13.4	5932	\$ 95.00	G	13.7	A110SRM1-84***	\$ 4,200.00	ACE	3.60
5143	\$ 570.00	G	13.4	A110-30-11-84	\$ 480.00	AA	1.3	A110SRM2-84***	\$ 5,235.00	ACE	3.61
5145	\$ 397.50	G	13.4	A1103000RT-84	\$ 543.00	AA	1.10	A110SRM3-84***	\$ 5,235.00	ACE	3.60
5147	\$ 590.00	G	13.4	A110M-30-11-84	\$ 1,365.00	AA	1.3	A110SRM4-84***	\$ 5,663.00	ACE	3.61
5149	\$ 604.00	G	13.4	A110R-30-11-84	\$ 1,628.00	AA	1.3	A110SRMP-84***	\$ 4,700.00	ACE	3.61
5151	\$ 474.00	G	13.4	A110S-84*	\$ 765.00	AA	3.14	A110SRMX-84***	\$ 7,415.00	ACE	3.61
5153	\$ 432.50	G	13.4	A110S1-84*	\$ 1,170.00	AAE	3.14	A110SRP-84*	\$ 3,230.00	AAE	3.19
5163	\$ 442.00	G	13.4	A110S2-84*	\$ 1,515.00	AAE	3.15	A110SRX-84*	\$ 4,479.00	AAE	3.19
5165	\$ 319.00	G	13.4	A110S3-84*	\$ 1,515.00	AAE	3.14	A110SS-84*	\$ 765.00	AA	3.16
5167	\$ 488.00	G	13.4	A110S4-84*	\$ 2,100.00	AAE	3.15	A110SS1-84*	\$ 1,170.00	AAE	3.16
5169	\$ 468.00	G	13.4	A110S7-84*	\$ 5,550.00	AXE	3.15	A110SS2-84*	\$ 1,515.00	AAE	3.17
5171	\$ 430.00	G	13.4	A110SA-84*	\$ 9,972.00	RVA	3.74	A110SS3-84*	\$ 1,515.00	AAE	3.17

A110SS4-84* – A145NST2-84*1*

Catalog number	List price	Discount schedule	Page number	Catalog number	List price	Discount schedule	Page number	Catalog number	List price	Discount schedule	Page number
A110SS4-84*	\$ 2,100.00	AAE	3.17	A12SNX-84*	\$ 1,630.00	ACE	3.51	A145NS2-84*	\$ 2,130.00	AEAE	3.15
A110SSP-84*	\$ 1,440.00	AAE	3.17	A12SP-84*	\$ 345.00	AAE	3.15	A145NS3-84*	\$ 2,130.00	AAE	3.14
A110SSX-84*	\$ 2,813.00	AAE	3.17	A12SR-84*	\$ 387.00	AA	3.18	A145NS4-84*	\$ 2,700.00	AEAE	3.15
A110ST-84*1*	\$ 2,681.00	AA	3.20	A12SR1-84*	\$ 585.00	AAE	3.18	A145NS7-84*	\$ 5,040.00	AXE	3.15
A110ST-84*2*	\$ 1,872.00	AA	3.22	A12SR2-84*	\$ 705.00	AAE	3.19	A145NSA1-84*	\$ 11,853.00	RVAE	3.74
A110ST1-84*1*	\$ 3,851.00	AAE	3.20	A12SR3-84*	\$ 705.00	AAE	3.19	A145NSA2-84*	\$ 14,013.00	RVAE	3.75
A110ST1-84*2*	\$ 3,042.00	AAE	3.22	A12SR4-84*	\$ 915.00	AAE	3.19	A145NSA3-84*	\$ 14,013.00	RVAE	3.75
A110ST2-84*1*	\$ 4,511.00	AAE	3.21	A12SRF1-84*6A	\$ 1,230.00	ACE	3.54	A145NSA4-84*	\$ 16,983.00	RVAE	3.75
A110ST2-84*2*	\$ 3,702.00	AAE	3.23	A12SRF2-84*6A	\$ 1,410.00	ACE	3.55	A145NSAX-84*	\$ 18,300.00	RVAE	3.75
A110ST3-84*1*	\$ 4,511.00	AAE	3.21	A12SRF3-84*6A	\$ 1,410.00	ACE	3.54	A145NSF1-84*6E	\$ 3,735.00	ACE	3.52
A110ST3-84*2*	\$ 3,702.00	AAE	3.23	A12SRF4-84*6A	\$ 1,515.00	ACE	3.55	A145NSF2-84*6E	\$ 5,183.00	ACE	3.53
A110ST4-84*1*	\$ 4,800.00	AAE	3.21	A12SRFP-84*6A	\$ 1,365.00	ACE	3.55	A145NSF3-84*6E	\$ 5,183.00	ACE	3.52
A110ST4-84*2*	\$ 3,863.00	AAE	3.23	A12SRFX-84*6A	\$ 2,045.00	ACE	3.55	A145NSF4-84*6E	\$ 5,685.00	ACE	3.53
A110STP-84*1*	\$ 4,300.00	AAE	3.21	A12SRM1-84***	\$ 1,275.00	ACE	3.60	A145NSFP-84*6E	\$ 4,880.00	ACE	3.53
A110STP-84*2*	\$ 3,300.00	AAE	3.23	A12SRM2-84***	\$ 1,455.00	ACE	3.61	A145NSFX-84*6E	\$ 7,455.00	ACE	3.53
A110STX-84*1*	\$ 5,358.00	AAE	3.21	A12SRM3-84***	\$ 1,455.00	ACE	3.60	A145NSG1-84**	\$ 11,333.00	WDAE	3.76
A110STX-84*2*	\$ 4,550.00	AAE	3.23	A12SRM4-84***	\$ 1,605.00	ACE	3.61	A145NSG2-84**	\$ 12,902.00	WDAE	3.77
A110SX-84*	\$ 2,813.00	AAE	3.15	A12SRMP-84***	\$ 1,410.00	ACE	3.61	A145NSG3-84**	\$ 12,902.00	WDAE	3.77
A110SY-84**	\$ 13,108.00	WDA	3.78	A12SRMX-84***	\$ 2,180.00	ACE	3.61	A145NSG4-84**	\$ 13,865.00	WDAE	3.77
A110SY1-84**	\$ 14,107.00	WDAE	3.78	A12SRP-84*	\$ 683.00	AAE	3.19	A145NSGX-84**	\$ 16,238.00	WDAE	3.77
A110SY2-84**	\$ 15,907.00	WDAE	3.79	A12SRX-84*	\$ 1,230.00	AAE	3.19	A145NSH1-84**	\$ 8,469.00	PWAE	3.80
A110SY3-84**	\$ 15,907.00	WDAE	3.79	A12SS-84*	\$ 171.00	AA	3.16	A145NSH2-84**	\$ 10,269.00	PWAE	3.81
A110SY4-84**	\$ 16,870.00	WDAE	3.79	A12SS1-84*	\$ 285.00	AAE	3.16	A145NSH3-84**	\$ 10,269.00	PWAE	3.81
A110SYX-84**	\$ 18,350.00	WDAE	3.79	A12SS2-84*	\$ 360.00	AAE	3.17	A145NSH4-84**	\$ 11,232.00	PWAE	3.81
A110W-30-11-84	\$ 480.00	AEA	1.116	A12SS3-84*	\$ 360.00	AAE	3.17	A145NSHX-84**	\$ 12,225.00	PWAE	3.81
A12-30-01-84	\$ 84.00	AA	1.3	A12SS4-84*	\$ 540.00	AAE	3.17	A145NSM1-84***	\$ 4,020.00	ACE	3.58
A12-30-10-84	\$ 84.00	AA	1.3	A12SSD-84*	\$ 248.00	AAE	3.24	A145NSM2-84***	\$ 5,235.00	ACE	3.59
A123001RT-84	\$ 87.00	AA	1.10	A12SSD-84*A	\$ 293.00	AAE	3.24	A145NSM3-84***	\$ 5,235.00	ACE	3.58
A123010RT-84	\$ 87.00	AA	1.10	A12SSD-84*R	\$ 255.00	AAE	3.24	A145NSM4-84***	\$ 5,588.00	ACE	3.59
A12M-30-01-84	\$ 315.00	AA	1.3	A12SSP-84*	\$ 345.00	AAE	3.17	A145NSM7-84***	\$ 13,595.00	AXE	3.59
A12M-30-10-84	\$ 315.00	AA	1.3	A12SSX-84*	\$ 713.00	AAE	3.17	A145NSMP-84***	\$ 5,400.00	ACE	3.59
A12R-30-01-84	\$ 375.00	AA	1.3	A12ST-84*1*	\$ 525.00	AA	3.20	A145NSMX-84***	\$ 7,650.00	ACE	3.59
A12R-30-10-84	\$ 375.00	AA	1.3	A12ST-84*12*	\$ 426.00	AA	3.22	A145NSN1-84*	\$ 3,675.00	ACE	3.50
A12S-84*	\$ 171.00	AA	3.14	A12ST1-84*1*	\$ 771.00	AAE	3.20	A145NSN2-84*	\$ 4,890.00	ACE	3.51
A12S1-84*	\$ 285.00	AAE	3.14	A12ST1-84*2*	\$ 657.00	AAE	3.22	A145NSN3-84*	\$ 4,890.00	ACE	3.50
A12S2-84*	\$ 360.00	AAE	3.15	A12ST2-84*1*	\$ 891.00	AAE	3.21	A145NSN4-84*	\$ 5,175.00	ACE	3.51
A12S3-84*	\$ 360.00	AAE	3.14	A12ST2-84*2*	\$ 777.00	AAE	3.23	A145NSNP-84*	\$ 4,360.00	ACE	3.51
A12S4-84*	\$ 540.00	AAE	3.15	A12ST3-84*1*	\$ 891.00	AAE	3.21	A145NSNX-84*	\$ 6,450.00	ACE	3.51
A12S7-84*	\$ 1,560.00	AXE	3.15	A12ST3-84*2*	\$ 777.00	AAE	3.23	A145NSP-84*	\$ 1,950.00	AEAE	3.15
A12SD-84*	\$ 248.00	AAE	3.24	A12ST4-84*1*	\$ 1,095.00	AAE	3.21	A145NSR1-84*	\$ 3,570.00	AEAE	3.18
A12SD-84*A	\$ 293.00	AAE	3.24	A12ST4-84*2*	\$ 990.00	AAE	3.23	A145NSR2-84*	\$ 4,275.00	AEAE	3.19
A12SD-84*R	\$ 255.00	AAE	3.24	A12STP-84*1*	\$ 869.00	AAE	3.21	A145NSR3-84*	\$ 4,275.00	AEAE	3.19
A12SF1-84*6A	\$ 915.00	ACE	3.52	A12STP-84*2*	\$ 755.00	AAE	3.23	A145NSR4-84*	\$ 4,650.00	AEAE	3.19
A12SF2-84*6A	\$ 1,095.00	ACE	3.53	A12STX-84*1*	\$ 1,416.00	AAE	3.21	A145NSRF1-84*6E	\$ 5,970.00	ACE	3.54
A12SF3-84*6A	\$ 1,095.00	ACE	3.52	A12STX-84*2*	\$ 1,302.00	AAE	3.23	A145NSRF2-84*6E	\$ 7,418.00	ACE	3.55
A12SF4-84*6A	\$ 1,380.00	ACE	3.53	A12SX-84*	\$ 713.00	AAE	3.15	A145NSRF3-84*6E	\$ 7,418.00	ACE	3.54
A12SFP-84*6A	\$ 1,035.00	ACE	3.53	A145-30-11-84	\$ 825.00	AEA	1.3	A145NSRF4-84*6E	\$ 7,800.00	ACE	3.55
A12SFX-84*6A	\$ 1,830.00	ACE	3.53	A145M-30-11-84	\$ 2,235.00	AEA	1.3	A145NSRFP-84*6E	\$ 7,600.00	ACE	3.55
A12SM1-84***	\$ 960.00	ACE	3.56	A145N4-30-11-84	\$ 825.00	AEA	1.11	A145NSRFX-84*6E	\$ 9,690.00	ACE	3.55
A12SM2-84***	\$ 1,140.00	ACE	3.57	A145N4M-11-84	\$ 2,235.00	AEA	1.11	A145NSRM1-84***	\$ 6,285.00	ACE	3.62
A12SM3-84***	\$ 1,140.00	ACE	3.56	A145N4R-11-84	\$ 2,250.00	AEA	1.11	A145NSRM2-84***	\$ 7,470.00	ACE	3.63
A12SM4-84***	\$ 1,290.00	ACE	3.57	A145N4S-84*	\$ 1,315.00	AEA	3.14	A145NSRM3-84***	\$ 7,470.00	ACE	3.62
A12SM7-84***	\$ 2,850.00	AXE	3.57	A145N4SA-84*	\$ 10,863.00	RVA	3.74	A145NSRM4-84***	\$ 7,950.00	ACE	3.63
A12SMP-84***	\$ 1,080.00	ACE	3.57	A145N4SG-84**	\$ 10,103.00	WDA	3.76	A145NSRMP-84***	\$ 7,620.00	ACE	3.63
A12SMX-84***	\$ 1,865.00	ACE	3.57	A145N4SH-84**	\$ 8,001.00	PWA	3.80	A145NSRMX-84***	\$ 9,885.00	ACE	3.63
A12SN1-84*	\$ 855.00	ACE	3.50	A145N4SR-84*	\$ 2,297.00	AEA	3.18	A145NSRP-84*	\$ 3,804.00	AEAE	3.19
A12SN2-84*	\$ 1,035.00	ACE	3.51	A145N4ST-84*1*	\$ 4,506.00	AEA	3.20	A145NSRX-84*	\$ 5,665.00	AEAE	3.19
A12SN3-84*	\$ 1,035.00	ACE	3.50	A145N4ST-84*2*	\$ 3,069.00	AEA	3.22	A145NST1-84*1*	\$ 5,079.00	AEAE	3.20
A12SN4-84*	\$ 1,320.00	ACE	3.51	A145N4SY-84**	\$ 14,324.00	WDA	3.78	A145NST1-84*2*	\$ 3,642.00	AEAE	3.22
A12SNP-84*	\$ 975.00	ACE	3.51	A145NS1-84*	\$ 1,765.00	AAE	3.14	A145NST2-84*1*	\$ 5,784.00	AEAE	3.21

A145NST2-84*2* – A16NSRP-84*

Alphanumeric

0

Catalog number	List price	Discount schedule	Page number	Catalog number	List price	Discount schedule	Page number	Catalog number	List price	Discount schedule	Page number
A145NST2-84*2*	\$ 4,347.00	AEAE	3.23	A145SR-84*	\$ 2,997.00	AEA	3.18	A16N0R-10-84	\$ 413.00	AA	1.11
A145NST3-84*1*	\$ 5,784.00	AEAE	3.21	A145SR1-84*	\$ 3,570.00	AEAE	3.18	A16N0S-84*	\$ 200.00	AA	3.14
A145NST3-84*2*	\$ 4,347.00	AEAE	3.23	A145SR2-84*	\$ 4,275.00	AEAE	3.19	A16N0SA-84*	\$ 3,987.00	RVA	3.74
A145NST4-84*1*	\$ 6,265.00	AEAE	3.21	A145SR3-84*	\$ 4,275.00	AEAE	3.19	A16N0SP-84*	\$ 360.00	AAE	3.17
A145NST4-84*2*	\$ 4,650.00	AEAE	3.23	A145SR4-84*	\$ 4,650.00	AEAE	3.19	A16N0SR-84*	\$ 443.00	AA	3.18
A145NSTP-84*1*	\$ 5,513.00	AEAE	3.21	A145SRF1-84*6E	\$ 5,970.00	ACE	3.54	A16N0SS-84*	\$ 200.00	AA	3.16
A145NSTP-84*2*	\$ 3,919.00	AEAE	3.23	A145SRF2-84*6E	\$ 7,418.00	ACE	3.55	A16N0SS1-84*	\$ 300.00	AAE	3.16
A145NSTX-84*1*	\$ 7,175.00	AEAE	3.21	A145SRF3-84*6E	\$ 7,418.00	ACE	3.54	A16N0SS2-84*	\$ 383.00	AAE	3.17
A145NSTX-84*2*	\$ 5,735.00	AEAE	3.23	A145SRF4-84*6E	\$ 7,800.00	ACE	3.55	A16N0SS3-84*	\$ 383.00	AAE	3.17
A145NSX-84*	\$ 3,375.00	AEAE	3.15	A145SRFP-84*6E	\$ 7,600.00	ACE	3.55	A16N0SS4-84*	\$ 570.00	AAE	3.17
A145NSY1-84**	\$ 15,323.00	WDAE	3.78	A145SRFX-84*6E	\$ 9,690.00	ACE	3.55	A16N0ST-84*1*	\$ 581.00	AA	3.20
A145NSY2-84**	\$ 17,023.00	WDAE	3.79	A145SRM1-84***	\$ 4,335.00	ACE	3.60	A16N0ST-84*2*	\$ 476.00	AA	3.22
A145NSY3-84**	\$ 17,123.00	WDAE	3.79	A145SRM2-84***	\$ 7,470.00	ACE	3.61	A16N0SX-84*	\$ 743.00	AAE	3.17
A145NSY4-84**	\$ 18,086.00	WDAE	3.79	A145SRM3-84***	\$ 7,470.00	ACE	3.60	A16NS1-84*	\$ 300.00	AAE	3.14
A145NSYX-84**	\$ 19,950.00	WDAE	3.79	A145SRM4-84***	\$ 7,950.00	ACE	3.61	A16NS2-84*	\$ 383.00	AAE	3.15
A145R-30-11-84	\$ 2,250.00	AEA	1.3	A145SRMP-84***	\$ 7,620.00	ACE	3.61	A16NS3-84*	\$ 383.00	AAE	3.14
A145S-84*	\$ 1,315.00	AEA	3.14	A145SRMX-84***	\$ 9,885.00	ACE	3.61	A16NS4-84*	\$ 570.00	AAE	3.15
A145S1-84*	\$ 1,765.00	AAE	3.14	A145SRP-84*	\$ 3,804.00	AEAE	3.19	A16NS7-84*	\$ 1,278.00	AXE	3.15
A145S2-84*	\$ 2,130.00	AEAE	3.15	A145SRX-84*	\$ 5,665.00	AEAE	3.19	A16NSA1-84*	\$ 5,103.00	RVAE	3.74
A145S3-84*	\$ 2,130.00	AAE	3.14	A145SS-84*	\$ 1,315.00	AEA	3.16	A16NSA2-84*	\$ 5,823.00	RVAE	3.75
A145S4-84*	\$ 2,700.00	AEAE	3.15	A145SS1-84*	\$ 1,765.00	AEA	3.16	A16NSA3-84*	\$ 5,823.00	RVAE	3.75
A145S7-84*	\$ 6,040.00	AXE	3.15	A145SS2-84*	\$ 2,130.00	AEAE	3.17	A16NSA4-84*	\$ 6,993.00	RVAE	3.75
A145SA-84*	\$ 10,863.00	RVA	3.74	A145SS3-84*	\$ 2,130.00	AEAE	3.17	A16NSAX-84*	\$ 8,550.00	RVAE	3.75
A145SA1-84*	\$ 11,853.00	RVAE	3.74	A145SS4-84*	\$ 2,700.00	AEAE	3.17	A16NSF1-84*6A	\$ 945.00	ACE	3.52
A145SA2-84*	\$ 14,013.00	RVAE	3.75	A145SSP-84*	\$ 1,950.00	AEAE	3.17	A16NSF2-84*6A	\$ 1,125.00	ACE	3.53
A145SA3-84*	\$ 14,013.00	RVAE	3.75	A145SSX-84*	\$ 3,375.00	AEAE	3.17	A16NSF3-84*6A	\$ 1,125.00	ACE	3.52
A145SA4-84*	\$ 16,983.00	RVAE	3.75	A145ST-84*1*	\$ 4,506.00	AEA	3.20	A16NSF4-84*6A	\$ 1,425.00	ACE	3.53
A145SAX-84*	\$ 18,300.00	RVAE	3.75	A145ST-84*2*	\$ 3,069.00	AEA	3.22	A16NSFP-84*6A	\$ 1,065.00	ACE	3.53
A145SF1-84*6E	\$ 3,735.00	ACE	3.52	A145ST1-84*1*	\$ 5,079.00	AEAE	3.20	A16NSFX-84*6A	\$ 1,860.00	ACE	3.53
A145SF2-84*6E	\$ 5,183.00	ACE	3.53	A145ST1-84*2*	\$ 3,642.00	AEAE	3.22	A16NSM1-84***	\$ 990.00	ACE	3.58
A145SF3-84*6E	\$ 5,183.00	ACE	3.52	A145ST2-84*1*	\$ 5,784.00	AEAE	3.21	A16NSM2-84***	\$ 1,170.00	ACE	3.59
A145SF4-84*6E	\$ 5,685.00	ACE	3.53	A145ST2-84*2*	\$ 4,347.00	AEAE	3.23	A16NSM3-84***	\$ 1,170.00	ACE	3.58
A145SFP-84*6E	\$ 4,880.00	ACE	3.53	A145ST3-84*1*	\$ 5,784.00	AEAE	3.21	A16NSM4-84***	\$ 1,320.00	ACE	3.59
A145SFX-84*6E	\$ 7,455.00	ACE	3.53	A145ST3-84*2*	\$ 4,347.00	AEAE	3.23	A16NSMP-84***	\$ 3,030.00	AXE	3.59
A145SG-84**	\$ 10,103.00	WDA	3.76	A145ST4-84*1*	\$ 6,265.00	AEAE	3.21	A16NSMR-84***	\$ 1,050.00	ACE	3.59
A145SG1-84**	\$ 11,333.00	WDAE	3.76	A145ST4-84*2*	\$ 4,650.00	AEAE	3.23	A16NSMX-84***	\$ 1,895.00	ACE	3.59
A145SG2-84**	\$ 12,902.00	WDAE	3.77	A145STP-84*1*	\$ 5,513.00	AEAE	3.21	A16NSN1-84*	\$ 885.00	ACE	3.50
A145SG3-84**	\$ 12,902.00	WDAE	3.77	A145STP-84*2*	\$ 3,919.00	AEAE	3.23	A16NSN2-84*	\$ 1,065.00	ACE	3.51
A145SG4-84**	\$ 13,865.00	WDAE	3.77	A145STX-84*1*	\$ 7,175.00	AEAE	3.21	A16NSN3-84*	\$ 1,065.00	ACE	3.50
A145SGX-84**	\$ 16,238.00	WDAE	3.77	A145STX-84*2*	\$ 5,735.00	AEAE	3.23	A16NSN4-84*	\$ 1,365.00	ACE	3.51
A145SH-84**	\$ 8,001.00	PWA	3.80	A145SX-84*	\$ 3,375.00	AEAE	3.15	A16NSNP-84*	\$ 1,005.00	ACE	3.51
A145SH1-84**	\$ 8,469.00	PWAE	3.80	A145SY-84**	\$ 14,324.00	WDA	3.78	A16NSNX-84*	\$ 1,675.00	ACE	3.51
A145SH2-84**	\$ 10,269.00	PWAE	3.81	A145SY1-84**	\$ 15,323.00	WDAE	3.78	A16NSP-84*	\$ 360.00	AAE	3.15
A145SH3-84**	\$ 10,269.00	PWAE	3.81	A145SY2-84**	\$ 17,023.00	WDAE	3.79	A16NSR1-84*	\$ 630.00	AAE	3.18
A145SH4-84**	\$ 11,232.00	PWAE	3.81	A145SY3-84**	\$ 17,123.00	WDAE	3.79	A16NSR2-84*	\$ 750.00	AAE	3.19
A145SHX-84**	\$ 12,225.00	PWAE	3.81	A145SY4-84**	\$ 18,086.00	WDAE	3.79	A16NSR3-84*	\$ 750.00	AAE	3.19
A145SM1-84***	\$ 4,020.00	ACE	3.56	A145SYX-84**	\$ 19,950.00	WDAE	3.79	A16NSR4-84*	\$ 990.00	AAE	3.19
A145SM2-84***	\$ 5,235.00	ACE	3.57	A145W-20-11-84	\$ 750.00	AEA	1.116	A16NSRF1-84*6A	\$ 1,290.00	ACE	3.54
A145SM3-84***	\$ 5,235.00	ACE	3.56	A145W-30-11-84	\$ 825.00	AEA	1.116	A16NSRF2-84*6A	\$ 1,470.00	ACE	3.55
A145SM4-84***	\$ 5,588.00	ACE	3.57	A16-04-00-84	\$ 165.00	AA	1.13	A16NSRF3-84*6A	\$ 1,470.00	ACE	3.54
A145SM7-84***	\$ 13,595.00	AXE	3.57	A16-22-00-84	\$ 165.00	AA	1.13	A16NSRF4-84*6A	\$ 1,575.00	ACE	3.55
A145SMP-84***	\$ 5,400.00	ACE	3.57	A16-30-01-84	\$ 102.00	AA	1.3	A16NSRFP-84*6A	\$ 1,425.00	ACE	3.55
A145SMX-84***	\$ 7,650.00	ACE	3.57	A16-30-10-84	\$ 102.00	AA	1.3	A16NSRFX-84*6A	\$ 2,105.00	ACE	3.55
A145SN1-84*	\$ 3,675.00	ACE	3.50	A16-40-00-84	\$ 165.00	AA	1.13	A16NSRM1-84***	\$ 1,335.00	ACE	3.62
A145SN2-84*	\$ 4,890.00	ACE	3.51	A163001RT-84	\$ 106.00	AA	1.10	A16NSRM2-84***	\$ 1,515.00	ACE	3.63
A145SN3-84*	\$ 4,890.00	ACE	3.50	A163010RT-84	\$ 106.00	AA	1.10	A16NSRM3-84***	\$ 1,515.00	ACE	3.62
A145SN4-84*	\$ 5,175.00	ACE	3.51	A16M-30-01-84	\$ 345.00	AA	1.3	A16NSRM4-84***	\$ 1,688.00	ACE	3.63
A145SNP-84*	\$ 4,360.00	ACE	3.51	A16M-30-10-84	\$ 345.00	AA	1.3	A16NSRMP-84***	\$ 1,470.00	ACE	3.63
A145SNX-84*	\$ 6,450.00	ACE	3.51	A16N0-30-10-84	\$ 102.00	AA	1.11	A16NSRMX-84***	\$ 2,240.00	ACE	3.63
A145SP-84*	\$ 1,950.00	AEAE	3.15	A16N0M-10-84	\$ 345.00	AA	1.11	A16NSRP-84*	\$ 765.00	AAE	3.19

A16NSRX-84* – A185STP-84*2*

Catalog number	List price	Discount schedule	Page number	Catalog number	List price	Discount schedule	Page number	Catalog number	List price	Discount schedule	Page number
A16NSRX-84*	\$ 1,313.00	AAE	3.19	A16SRFP-84*6A	\$ 1,425.00	ACE	3.55	A185SG4-84**	\$ 15,150.00	WDAE	3.77
A16NST1-84*1*	\$ 837.00	AAE	3.20	A16SRFX-84*6A	\$ 2,105.00	ACE	3.55	A185SGX-84**	\$ 18,150.00	WDAE	3.77
A16NST1-84*2*	\$ 702.00	AAE	3.22	A16SRM1-84***	\$ 1,335.00	ACE	3.60	A185SH-84**	\$ 10,098.00	PWA	3.80
A16NST2-84*1*	\$ 957.00	AAE	3.21	A16SRM2-84***	\$ 1,515.00	ACE	3.61	A185SH1-84**	\$ 10,569.00	PWAE	3.80
A16NST2-84*2*	\$ 822.00	AAE	3.23	A16SRM3-84***	\$ 1,515.00	ACE	3.60	A185SH2-84**	\$ 12,369.00	PWAE	3.81
A16NST3-84*1*	\$ 957.00	AAE	3.21	A16SRM4-84***	\$ 1,688.00	ACE	3.61	A185SH3-84**	\$ 12,369.00	PWAE	3.81
A16NST3-84*2*	\$ 822.00	AAE	3.23	A16SRMP-84***	\$ 1,470.00	ACE	3.61	A185SH4-84**	\$ 13,332.00	PWAE	3.81
A16NST4-84*1*	\$ 1,215.00	AAE	3.21	A16SRMX-84***	\$ 2,240.00	ACE	3.61	A185SHX-84**	\$ 14,813.00	PWAE	3.81
A16NST4-84*2*	\$ 1,065.00	AAE	3.23	A16SRP-84*	\$ 765.00	AAE	3.19	A185SM1-84***	\$ 4,950.00	ACE	3.56
A16NSTP-84*1*	\$ 972.00	AAE	3.21	A16SRX-84*	\$ 1,313.00	AAE	3.19	A185SM2-84***	\$ 5,610.00	ACE	3.57
A16NSTP-84*2*	\$ 837.00	AAE	3.23	A16SS-84*	\$ 200.00	AA	3.16	A185SM3-84***	\$ 5,610.00	ACE	3.56
A16NSTX-84*1*	\$ 1,520.00	AAE	3.21	A16SS1-84*	\$ 300.00	AAE	3.16	A185SM4-84***	\$ 6,300.00	ACE	3.57
A16NSTX-84*2*	\$ 1,385.00	AAE	3.23	A16SS2-84*	\$ 383.00	AAE	3.17	A185SM7-84***	\$ 14,475.00	AXE	3.57
A16NSX-84*	\$ 743.00	AAE	3.15	A16SS3-84*	\$ 383.00	AAE	3.17	A185SMP-84***	\$ 6,150.00	ACE	3.57
A16R-30-01-84	\$ 413.00	AA	1.3	A16SS4-84*	\$ 570.00	AAE	3.17	A185SMX-84***	\$ 9,150.00	ACE	3.57
A16R-30-10-84	\$ 413.00	AA	1.3	A16SSD-84*	\$ 278.00	AAE	3.24	A185SN1-84*	\$ 4,050.00	ACE	3.50
A16S-84*	\$ 200.00	AA	3.14	A16SSD-84*A	\$ 330.00	AAE	3.24	A185SN2-84*	\$ 5,250.00	ACE	3.51
A16S1-84*	\$ 300.00	AAE	3.14	A16SSD-84*R	\$ 293.00	AAE	3.24	A185SN3-84*	\$ 5,250.00	ACE	3.50
A16S2-84*	\$ 383.00	AAE	3.15	A16SSP-84*	\$ 360.00	AAE	3.17	A185SN4-84*	\$ 5,775.00	ACE	3.51
A16S3-84*	\$ 383.00	AAE	3.14	A16SSX-84*	\$ 743.00	AAE	3.17	A185SNP-84*	\$ 5,100.00	ACE	3.51
A16S4-84*	\$ 570.00	AAE	3.15	A16ST-84*1*	\$ 581.00	AA	3.20	A185SNX-84*	\$ 7,650.00	ACE	3.51
A16S7-84*	\$ 1,590.00	AXE	3.15	A16ST-84*2*	\$ 476.00	AA	3.22	A185SP-84*	\$ 2,440.00	AEAE	3.15
A16SA-84*	\$ 3,987.00	RVA	3.74	A16ST1-84*1*	\$ 837.00	AAE	3.20	A185SR-84*	\$ 3,996.00	AEA	3.18
A16SA1-84*	\$ 5,103.00	RVAE	3.74	A16ST1-84*2*	\$ 702.00	AAE	3.22	A185SR1-84*	\$ 4,755.00	AEAE	3.18
A16SA2-84*	\$ 5,823.00	RVAE	3.75	A16ST2-84*1*	\$ 957.00	AAE	3.21	A185SR2-84*	\$ 5,215.00	AEAE	3.19
A16SA3-84*	\$ 5,823.00	RVAE	3.75	A16ST2-84*2*	\$ 822.00	AAE	3.23	A185SR3-84*	\$ 5,215.00	AEAE	3.19
A16SA4-84*	\$ 6,993.00	RVAE	3.75	A16ST3-84*1*	\$ 957.00	AAE	3.21	A185SR4-84*	\$ 5,550.00	AEAE	3.19
A16SAX-84*	\$ 8,550.00	RVAE	3.75	A16ST3-84*2*	\$ 822.00	AAE	3.23	A185SRF1-84*6E	\$ 8,010.00	ACE	3.54
A16SD-84*	\$ 278.00	AAE	3.24	A16ST4-84*1*	\$ 1,215.00	AAE	3.21	A185SRF2-84*6E	\$ 8,760.00	ACE	3.55
A16SD-84*A	\$ 330.00	AAE	3.24	A16ST4-84*2*	\$ 1,065.00	AAE	3.23	A185SRF3-84*6E	\$ 8,760.00	ACE	3.54
A16SD-84*R	\$ 293.00	AAE	3.24	A16STP-84*1*	\$ 972.00	AAE	3.21	A185SRF4-84*6E	\$ 9,225.00	ACE	3.55
A16SF1-84*6A	\$ 945.00	ACE	3.52	A16STP-84*2*	\$ 837.00	AAE	3.23	A185SRFP-84*6E	\$ 9,000.00	ACE	3.55
A16SF2-84*6A	\$ 1,125.00	ACE	3.53	A16STX-84*1*	\$ 1,520.00	AAE	3.21	A185SRFX-84*6E	\$ 12,225.00	ACE	3.55
A16SF3-84*6A	\$ 1,125.00	ACE	3.52	A16STX-84*2*	\$ 1,385.00	AAE	3.23	A185SRM1-84***	\$ 6,285.00	ACE	3.60
A16SF4-84*6A	\$ 1,425.00	ACE	3.53	A16SX-84*	\$ 743.00	AAE	3.15	A185SRM2-84***	\$ 8,970.00	ACE	3.61
A16SFP-84*6A	\$ 1,065.00	ACE	3.53	A185-30-11-84	\$ 1,290.00	AEA	1.3	A185SRM3-84***	\$ 8,970.00	ACE	3.60
A16SFX-84*6A	\$ 1,860.00	ACE	3.53	A185M-30-11-84	\$ 3,360.00	AEA	1.3	A185SRM4-84***	\$ 9,638.00	ACE	3.61
A16SM1-84***	\$ 990.00	ACE	3.56	A185R-30-11-84	\$ 3,375.00	AEA	1.3	A185SRMP-84***	\$ 9,250.00	ACE	3.61
A16SM2-84***	\$ 1,170.00	ACE	3.57	A185S-84*	\$ 1,730.00	AEA	3.14	A185SRMX-84***	\$ 12,510.00	ACE	3.61
A16SM3-84***	\$ 1,170.00	ACE	3.56	A185S1-84*	\$ 2,400.00	AAE	3.14	A185SRP-84*	\$ 4,640.00	AEAE	3.19
A16SM4-84***	\$ 1,320.00	ACE	3.57	A185S2-84*	\$ 2,805.00	AEAE	3.15	A185SRX-84*	\$ 6,555.00	AEAE	3.19
A16SM7-84***	\$ 3,030.00	AXE	3.57	A185S3-84*	\$ 2,805.00	AAE	3.14	A185SS-84*	\$ 1,728.00	AEA	3.16
A16SMP-84***	\$ 1,110.00	ACE	3.57	A185S4-84*	\$ 3,340.00	AEAE	3.15	A185SS1-84*	\$ 2,400.00	AEA	3.16
A16SMX-84***	\$ 1,865.00	ACE	3.57	A185S7-84*	\$ 8,100.00	AXE	3.15	A185SS2-84*	\$ 2,805.00	AEAE	3.17
A16SN1-84*	\$ 885.00	ACE	3.50	A185SA-84*	\$ 14,334.00	RVA	3.74	A185SS3-84*	\$ 2,805.00	AEAE	3.17
A16SN2-84*	\$ 1,065.00	ACE	3.51	A185SA1-84*	\$ 16,880.00	RVAE	3.74	A185SS4-84*	\$ 3,340.00	AEAE	3.17
A16SN3-84*	\$ 1,065.00	ACE	3.50	A185SA2-84*	\$ 18,972.00	RVAE	3.75	A185SSP-84*	\$ 2,440.00	AEAE	3.17
A16SN4-84*	\$ 1,365.00	ACE	3.51	A185SA3-84*	\$ 18,972.00	RVAE	3.75	A185SSX-84*	\$ 3,900.00	AEAE	3.17
A16SNP-84*	\$ 1,005.00	ACE	3.51	A185SF4-84*6E	\$ 21,951.00	RVAE	3.75	A185ST-84*1*	\$ 5,845.00	AEA	3.20
A16SNX-84*	\$ 1,675.00	ACE	3.51	A185SAX-84*	\$ 24,450.00	RVAE	3.75	A185ST-84*2*	\$ 4,068.00	AEA	3.22
A16SP-84*	\$ 360.00	AAE	3.15	A185SF1-84*6E	\$ 4,650.00	ACE	3.52	A185ST1-84*1*	\$ 6,605.00	AEAE	3.20
A16SR-84*	\$ 443.00	AA	3.18	A185SF2-84*6E	\$ 5,400.00	ACE	3.53	A185ST1-84*2*	\$ 4,827.00	AEAE	3.22
A16SR1-84*	\$ 630.00	AAE	3.18	A185SF3-84*6E	\$ 5,400.00	ACE	3.52	A185ST2-84*1*	\$ 7,059.00	AEAE	3.21
A16SR2-84*	\$ 750.00	AAE	3.19	A185SF4-84*6E	\$ 6,200.00	ACE	3.53	A185ST2-84*2*	\$ 5,285.00	AEAE	3.23
A16SR3-84*	\$ 750.00	AAE	3.19	A185SFP-84*6E	\$ 5,400.00	ACE	3.53	A185ST3-84*1*	\$ 7,059.00	AEAE	3.21
A16SR4-84*	\$ 990.00	AAE	3.19	A185SFX-84*6E	\$ 8,865.00	ACE	3.53	A185ST3-84*2*	\$ 5,285.00	AEAE	3.23
A16SRF1-84*6A	\$ 1,290.00	ACE	3.54	A185SG-84**	\$ 13,133.00	WDA	3.76	A185ST4-84*1*	\$ 7,440.00	AEAE	3.21
A16SRF2-84*6A	\$ 1,470.00	ACE	3.55	A185SG1-84**	\$ 14,120.00	WDAE	3.76	A185ST4-84*2*	\$ 5,740.00	AEAE	3.23
A16SRF3-84*6A	\$ 1,470.00	ACE	3.54	A185SG2-84**	\$ 14,385.00	WDAE	3.77	A185STP-84*1*	\$ 6,729.00	AEAE	3.21
A16SRF4-84*6A	\$ 1,575.00	ACE	3.55	A185SG3-84**	\$ 14,385.00	WDAE	3.77	A185STP-84*2*	\$ 4,857.00	AEAE	3.23

A185STX-84*1* – A260NST2-84*2*

Alphanumeric

0

Catalog number	List price	Discount schedule	Page number	Catalog number	List price	Discount schedule	Page number	Catalog number	List price	Discount schedule	Page number
A185STX-84*1*	\$ 8,400.00	AEAE	3.21	A210SR1-84*	\$ 5,580.00	AEAE	3.18	A260NASX-84*	\$ 29,400.00	RVAE	3.75
A185STX-84*2*	\$ 6,627.00	AEAE	3.23	A210SR2-84*	\$ 6,255.00	AEAE	3.19	A260NS1-84*	\$ 3,825.00	AAE	3.14
A185SX-84*	\$ 3,900.00	AEAE	3.15	A210SR3-84*	\$ 6,255.00	AEAE	3.19	A260NS2-84*	\$ 4,650.00	AEAE	3.15
A185SY-84**	\$ 20,174.00	WDA	3.78	A210SR4-84*	\$ 6,640.00	AEAE	3.19	A260NS3-84*	\$ 4,650.00	AAE	3.14
A185SY1-84**	\$ 21,173.00	WDAE	3.78	A210SRF1-84*6E	\$ 10,905.00	ACE	3.54	A260NS4-84*	\$ 5,175.00	AEAE	3.15
A185SY2-84**	\$ 22,973.00	WDAE	3.79	A210SRF2-84*6E	\$ 12,885.00	ACE	3.55	A260NS7-84*	\$ 11,740.00	AXE	3.15
A185SY3-84**	\$ 22,973.00	WDAE	3.79	A210SRF3-84*6E	\$ 12,885.00	ACE	3.54	A260NSA1-84*	\$ 21,668.00	RVAE	3.74
A185SY4-84**	\$ 28,436.00	WDAE	3.79	A210SRF4-84*6E	\$ 13,238.00	ACE	3.55	A260NSA2-84*	\$ 24,098.00	RVAE	3.75
A185SYX-84**	\$ 30,225.00	WDAE	3.79	A210SRFP-84*6E	\$ 13,000.00	ACE	3.55	A260NSA3-84*	\$ 24,098.00	RVAE	3.75
A185W-20-11-84	\$ 1,180.00	AEA	1.116	A210SRFX-84*6E	\$ 16,410.00	ACE	3.55	A260NSF1-84*6E	\$ 7,680.00	ACE	3.52
A185W-30-11-84	\$ 1,290.00	AEA	1.116	A210SRM1-84***	\$ 8,310.00	ACE	3.60	A260NSF2-84*6E	\$ 9,930.00	ACE	3.53
A206SH4-84**	\$ 22,869.00	PWAE	3.81	A210SRM2-84***	\$ 13,080.00	ACE	3.61	A260NSF3-84*6E	\$ 9,930.00	ACE	3.52
A210-30-11-84	\$ 1,635.00	AEA	1.3	A210SRM3-84***	\$ 13,080.00	ACE	3.60	A260NSF4-84*6E	\$ 10,950.00	ACE	3.53
A210M-30-11-84	\$ 4,035.00	AEA	1.3	A210SRM4-84***	\$ 13,650.00	ACE	3.61	A260NSFP-84*6E	\$ 10,100.00	ACE	3.53
A210R-30-11-84	\$ 4,050.00	AEA	1.3	A210SRMP-84***	\$ 1,330.00	ACE	3.61	A260NSFX-84*6E	\$ 16,800.00	ACE	3.53
A210S-84*	\$ 2,135.00	AEA	3.14	A210SRMX-84***	\$ 16,545.00	ACE	3.61	A260NSG1-84**	\$ 19,958.00	WDAE	3.76
A210S1-84*	\$ 2,650.00	AAE	3.14	A210SRP-84*	\$ 5,566.00	AEAE	3.19	A260NSG2-84**	\$ 22,388.00	WDAE	3.77
A210S2-84*	\$ 3,375.00	AEAE	3.15	A210SRX-84*	\$ 7,680.00	AEAE	3.19	A260NSG3-84**	\$ 22,388.00	WDAE	3.77
A210S3-84*	\$ 3,375.00	AAE	3.14	A210ST-84*1*	\$ 6,895.00	AEA	3.20	A260NSG4-84**	\$ 25,088.00	WDAE	3.77
A210S4-84*	\$ 3,900.00	AEAE	3.15	A210ST-84*2*	\$ 4,722.00	AEA	3.22	A260NSGX-84**	\$ 27,338.00	WDAE	3.77
A210S7-84*	\$ 9,600.00	AXE	3.15	A210ST1-84*1*	\$ 7,825.00	AEAE	3.20	A260NSH1-84**	\$ 17,739.00	PWAE	3.80
A210SA-84*	\$ 17,196.00	RVA	3.74	A210ST1-84*2*	\$ 5,652.00	AEAE	3.22	A260NSH2-84**	\$ 20,169.00	PWAE	3.81
A210SA1-84*	\$ 19,781.00	RVAE	3.74	A210ST2-84*1*	\$ 8,500.00	AEAE	3.21	A260NSH3-84**	\$ 20,169.00	PWAE	3.81
A210SA2-84*	\$ 21,842.00	RVAE	3.75	A210ST2-84*2*	\$ 6,327.00	AEAE	3.23	A260NSH4-84**	\$ 22,869.00	PWAE	3.81
A210SA3-84*	\$ 21,842.00	RVAE	3.75	A210ST3-84*1*	\$ 8,500.00	AEAE	3.21	A260NSHX-84**	\$ 26,100.00	PWAE	3.81
A210SA4-84*	\$ 24,812.00	RVAE	3.75	A210ST3-84*2*	\$ 6,327.00	AEAE	3.23	A260NSM1-84***	\$ 8,160.00	ACE	3.58
A210SAX-84*	\$ 27,600.00	RVAE	3.75	A210ST4-84*1*	\$ 8,890.00	AEAE	3.21	A260NSM2-84***	\$ 10,155.00	ACE	3.59
A210SF1-84*6E	\$ 6,870.00	ACE	3.52	A210ST4-84*2*	\$ 6,510.00	AEAE	3.23	A260NSM3-84***	\$ 10,155.00	ACE	3.58
A210SF2-84*6E	\$ 8,850.00	ACE	3.53	A210STP-84*1*	\$ 8,103.00	AEAE	3.21	A260NSM4-84***	\$ 10,950.00	ACE	3.59
A210SF3-84*6E	\$ 8,850.00	ACE	3.52	A210STP-84*2*	\$ 5,899.00	AEAE	3.23	A260NSMP-84***	\$ 18,650.00	ACE	3.59
A210SF4-84*6E	\$ 9,600.00	ACE	3.53	A210STX-84*1*	\$ 9,925.00	AEAE	3.21	A260NSMX-84***	\$ 17,250.00	ACE	3.59
A210SFP-84*6E	\$ 8,800.00	ACE	3.53	A210STX-84*2*	\$ 7,752.00	AEAE	3.23	A260NSN1-84*	\$ 6,090.00	ACE	3.50
A210SFX-84*6E	\$ 12,375.00	ACE	3.53	A210SX-84*	\$ 4,785.00	AEAE	3.15	A260NSN2-84*	\$ 8,085.00	ACE	3.51
A210SG-84**	\$ 15,498.00	WDA	3.76	A210SY-84**	\$ 23,054.00	WDA	3.78	A260NSN3-84*	\$ 8,085.00	ACE	3.50
A210SG1-84**	\$ 16,500.00	WDAE	3.76	A210SY1-84**	\$ 25,052.00	WDAE	3.78	A260NSN4-84*	\$ 9,600.00	ACE	3.51
A210SG2-84**	\$ 18,215.00	WDAE	3.77	A210SY2-84**	\$ 27,482.00	WDAE	3.79	A260NSNP-84*	\$ 8,750.00	ACE	3.51
A210SG3-84**	\$ 18,215.00	WDAE	3.77	A210SY3-84**	\$ 27,482.00	WDAE	3.79	A260NSNX-84*	\$ 16,500.00	ACE	3.51
A210SG4-84**	\$ 19,035.00	WDAE	3.77	A210SY4-84**	\$ 30,182.00	WDAE	3.79	A260NSP-84*	\$ 4,200.00	AEAE	3.15
A210SGX-84**	\$ 21,450.00	WDAE	3.77	A210SYX-84**	\$ 32,400.00	WDAE	3.79	A260NSR1-84*	\$ 7,615.00	AEAE	3.18
A210SH-84**	\$ 14,310.00	PWA	3.80	A210W-20-11-84	\$ 1,500.00	AEA	1.116	A260NSR2-84*	\$ 8,355.00	AEAE	3.19
A210SH1-84**	\$ 14,769.00	PWAE	3.80	A210W-30-11-84	\$ 1,635.00	AEA	1.116	A260NSR3-84*	\$ 8,355.00	AEAE	3.19
A210SH2-84**	\$ 16,569.00	PWAE	3.81	A25SY1-84**	\$ 4,721.00	WDAE	3.78	A260NSR4-84*	\$ 9,340.00	AEAE	3.19
A210SH3-84**	\$ 16,569.00	PWAE	3.81	A26-22-00-84	\$ 228.00	AA	1.13	A260NSRF1-84*6E	\$ 12,165.00	ACE	3.54
A210SH4-84**	\$ 17,532.00	PWAE	3.81	A26-30-01-84	\$ 183.00	AA	1.3	A260NSRF2-84*6E	\$ 14,415.00	ACE	3.55
A210SHX-84**	\$ 19,050.00	PWAE	3.81	A26-30-10-84	\$ 183.00	AA	1.3	A260NSRF3-84*6E	\$ 14,415.00	ACE	3.54
A210SM1-84***	\$ 7,080.00	ACE	3.56	A26-40-00-84	\$ 228.00	AA	1.13	A260NSRF4-84*6E	\$ 15,150.00	ACE	3.55
A210SM2-84***	\$ 9,045.00	ACE	3.57	A260-30-11-84	\$ 1,815.00	AEA	1.3	A260NSRFP-84*6E	\$ 14,885.00	ACE	3.55
A210SM3-84***	\$ 9,045.00	ACE	3.56	A260M-30-11-84	\$ 4,485.00	AEA	1.3	A260NSRFX-84*6E	\$ 21,285.00	ACE	3.55
A210SM4-84***	\$ 9,713.00	ACE	3.57	A260N5-30-11-84	\$ 1,815.00	AEA	1.11	A260NSRM1-84***	\$ 12,645.00	ACE	3.62
A210SM7-84***	\$ 17,775.00	AXE	3.57	A260N5M-11-84	\$ 4,485.00	AEA	1.11	A260NSRM2-84***	\$ 14,640.00	ACE	3.63
A210SMP-84***	\$ 9,500.00	ACE	3.57	A260N5R-11-84	\$ 4,500.00	AEA	1.11	A260NSRM3-84***	\$ 14,640.00	ACE	3.62
A210SMX-84***	\$ 12,510.00	ACE	3.57	A260N5S-84*	\$ 2,740.00	AEA	3.14	A260NSRM4-84***	\$ 15,450.00	ACE	3.63
A210SN1-84*	\$ 5,685.00	ACE	3.50	A260N5SA-84*	\$ 19,670.00	RVA	3.74	A260NSRMP-84***	\$ 15,000.00	ACE	3.63
A210SN2-84*	\$ 7,650.00	ACE	3.51	A260N5SG-84**	\$ 17,960.00	WDA	3.76	A260NSRMX-84***	\$ 21,735.00	ACE	3.63
A210SN3-84*	\$ 7,650.00	ACE	3.50	A260N5SH-84**	\$ 16,749.00	PWA	3.80	A260NSRP-84*	\$ 7,434.00	AEAE	3.19
A210SN4-84*	\$ 9,150.00	ACE	3.51	A260N5SR-84*	\$ 5,436.00	AEA	3.18	A260NSRX-84*	\$ 11,995.00	AEAE	3.19
A210SNP-84*	\$ 8,300.00	ACE	3.51	A260N5ST-84*1*	\$ 8,535.00	AEA	3.20	A260NST1-84*1*	\$ 10,710.00	AEAE	3.20
A210SNX-84*	\$ 12,000.00	ACE	3.51	A260N5ST-84*2*	\$ 5,508.00	AEA	3.22	A260NST1-84*2*	\$ 7,685.00	AEAE	3.22
A210SP-84*	\$ 3,000.00	AEAE	3.15	A260N5SY-84**	\$ 24,413.00	WDA	3.78	A260NST2-84*1*	\$ 11,455.00	AEAE	3.21
A210SR-84*	\$ 4,650.00	AEA	3.18	A260NAS4-84*	\$ 26,798.00	RVAE	3.75	A260NST2-84*2*	\$ 8,427.00	AEAE	3.23

A260NST3-84*1* – A26NSRF3-84*6A

Catalog number	List price	Discount schedule	Page number	Catalog number	List price	Discount schedule	Page number	Catalog number	List price	Discount schedule	Page number
A260NST3-84*1*	\$ 11,455.00	AEAE	3.21	A260SR3-84*	\$ 8,355.00	AEAE	3.19	A26N1SS4-84*	\$ 630.00	AAE	3.17
A260NST3-84*2*	\$ 8,427.00	AEAE	3.23	A260SR4-84*	\$ 9,340.00	AEAE	3.19	A26N1ST-84*1*	\$ 752.00	AA	3.20
A260NST4-84*1*	\$ 12,940.00	AEAE	3.21	A260SRF1-84*6E	\$ 12,165.00	ACE	3.54	A26N1ST-84*2*	\$ 552.00	AA	3.22
A260NST4-84*2*	\$ 9,150.00	AEAE	3.23	A260SRF2-84*6E	\$ 14,415.00	ACE	3.55	A26N1SX-84*	\$ 831.00	AAE	3.17
A260NSTP-84*1*	\$ 10,919.00	AEAE	3.21	A260SRF3-84*6E	\$ 14,415.00	ACE	3.54	A26N1SY-84**	\$ 4,667.00	WDA	3.78
A260NSTP-84*2*	\$ 7,512.00	AEAE	3.23	A260SRF4-84*6E	\$ 15,150.00	ACE	3.55	A26NS1-84*	\$ 405.00	AAE	3.14
A260NSTX-84*1*	\$ 15,090.00	AEAE	3.21	A260SRFP-84*6E	\$ 14,885.00	ACE	3.55	A26NS2-84*	\$ 465.00	AAE	3.15
A260NSTX-84*2*	\$ 12,065.00	AEAE	3.23	A260SRFX-84*6E	\$ 21,285.00	ACE	3.55	A26NS3-84*	\$ 465.00	AAE	3.14
A260NSX-84*	\$ 5,815.00	AEAE	3.15	A260SRM1-84***	\$ 8,160.00	ACE	3.60	A26NS4-84*	\$ 630.00	AAE	3.15
A260NSY1-84**	\$ 26,411.00	WDAE	3.78	A260SRM2-84***	\$ 14,640.00	ACE	3.61	A26NS7-84*	\$ 1,347.00	AXE	3.15
A260NSY2-84**	\$ 28,841.00	WDAE	3.79	A260SRM3-84***	\$ 14,640.00	ACE	3.60	A26NSA1-84*	\$ 5,457.00	RVAE	3.74
A260NSY3-84**	\$ 28,841.00	WDAE	3.79	A260SRM4-84***	\$ 15,450.00	ACE	3.61	A26NSA2-84*	\$ 6,117.00	RVAE	3.75
A260NSY4-84**	\$ 31,541.00	WDAE	3.79	A260SRMP-84***	\$ 15,000.00	ACE	3.61	A26NSA3-84*	\$ 6,117.00	RVAE	3.75
A260NSYX-84**	\$ 33,450.00	WDAE	3.79	A260SRMX-84***	\$ 21,735.00	ACE	3.61	A26NSA4-84*	\$ 7,347.00	RVAE	3.75
A260R-30-11-84	\$ 4,500.00	AEA	1.3	A260SRP-84*	\$ 7,434.00	AEAE	3.19	A26NSAX-84*	\$ 8,888.00	RVAE	3.75
A260S-84*	\$ 2,740.00	AEA	3.14	A260SRX-84*	\$ 11,995.00	AEAE	3.19	A26NSF1-84*6A	\$ 1,020.00	ACE	3.52
A260S1-84*	\$ 3,825.00	AAE	3.14	A260ST-84*1*	\$ 8,535.00	AEA	3.20	A26NSF1-84*6B	\$ 1,020.00	ACE	3.52
A260S2-84*	\$ 4,650.00	AEAE	3.15	A260ST-84*2*	\$ 5,500.00	AEA	3.22	A26NSF2-84*6A	\$ 1,230.00	ACE	3.53
A260S3-84*	\$ 4,650.00	AAE	3.14	A260ST1-84*1*	\$ 10,710.00	AEAE	3.20	A26NSF2-84*6B	\$ 1,230.00	ACE	3.53
A260S4-84*	\$ 5,175.00	AEAE	3.15	A260ST1-84*2*	\$ 7,685.00	AEAE	3.22	A26NSF3-84*6A	\$ 1,230.00	ACE	3.52
A260S7-84*	\$ 11,740.00	AXE	3.15	A260ST2-84*1*	\$ 11,455.00	AEAE	3.21	A26NSF3-84*6B	\$ 1,230.00	ACE	3.52
A260SA-84*	\$ 19,670.00	RVA	3.74	A260ST2-84*2*	\$ 8,427.00	AEAE	3.23	A26NSF4-84*6A	\$ 1,530.00	ACE	3.53
A260SA1-84*	\$ 21,668.00	RVAE	3.74	A260ST3-84*1*	\$ 11,455.00	AEAE	3.21	A26NSF4-84*6B	\$ 1,530.00	ACE	3.53
A260SA2-84*	\$ 24,098.00	RVAE	3.75	A260ST3-84*2*	\$ 8,427.00	AEAE	3.23	A26NSFP-84*6A	\$ 1,148.00	ACE	3.53
A260SA3-84*	\$ 24,098.00	RVAE	3.75	A260ST4-84*1*	\$ 12,940.00	AEAE	3.21	A26NSFP-84*6B	\$ 1,148.00	ACE	3.53
A260SA4-84*	\$ 26,798.00	RVAE	3.75	A260ST4-84*2*	\$ 9,150.00	AEAE	3.23	A26NSFX-84*6A	\$ 1,965.00	ACE	3.53
A260SAX-84*	\$ 29,400.00	RVAE	3.75	A260STP-84*1*	\$ 10,919.00	AEAE	3.21	A26NSFX-84*6B	\$ 1,965.00	ACE	3.53
A260SF1-84*6E	\$ 7,680.00	ACE	3.52	A260STP-84*2*	\$ 7,512.00	AEAE	3.23	A26NSG1-84**	\$ 3,092.00	WDAE	3.76
A260SF2-84*6E	\$ 9,930.00	ACE	3.53	A260STX-84*1*	\$ 15,090.00	AEAE	3.21	A26NSG2-84**	\$ 3,992.00	WDAE	3.77
A260SF3-84*6E	\$ 9,930.00	ACE	3.52	A260STX-84*2*	\$ 12,065.00	AEAE	3.23	A26NSG3-84**	\$ 3,992.00	WDAE	3.77
A260SF4-84*6E	\$ 10,950.00	ACE	3.53	A260SX-84*	\$ 5,815.00	AEAE	3.15	A26NSG4-84**	\$ 4,172.00	WDAE	3.77
A260SFP-84*6E	\$ 10,100.00	ACE	3.53	A260SY-84**	\$ 24,413.00	WDA	3.78	A26NSGX-84**	\$ 4,800.00	WDAE	3.77
A260SFX-84*6E	\$ 16,800.00	ACE	3.53	A260SY1-84**	\$ 26,411.00	WDAE	3.78	A26NSH1-84**	\$ 1,971.00	PWAE	3.80
A260SG-84**	\$ 17,960.00	WDA	3.76	A260SY2-84**	\$ 28,841.00	WDAE	3.79	A26NSH2-84**	\$ 2,871.00	PWAE	3.81
A260SG1-84**	\$ 19,958.00	WDAE	3.76	A260SY3-84**	\$ 28,841.00	WDAE	3.79	A26NSH3-84**	\$ 2,871.00	PWAE	3.81
A260SG2-84**	\$ 22,388.00	WDAE	3.77	A260SY4-84**	\$ 31,541.00	WDAE	3.79	A26NSH4-84**	\$ 3,051.00	PWAE	3.81
A260SG3-84**	\$ 22,388.00	WDAE	3.77	A260SYX-84**	\$ 33,450.00	WDAE	3.79	A26NSHX-84**	\$ 3,638.00	PWAE	3.81
A260SG4-84**	\$ 25,088.00	WDAE	3.77	A260W-20-11-84	\$ 1,675.00	AEA	1.116	A26NSM1-84***	\$ 1,073.00	ACE	3.58
A260SGX-84**	\$ 27,338.00	WDAE	3.77	A260W-30-11-84	\$ 1,815.00	AEA	1.116	A26NSM2-84***	\$ 1,253.00	ACE	3.59
A260SH-84**	\$ 16,749.00	PWA	3.80	A263001RT-84	\$ 189.00	AA	1.10	A26NSM3-84***	\$ 1,253.00	ACE	3.58
A260SH1-84**	\$ 17,739.00	PWAE	3.80	A263010RT-84	\$ 189.00	AA	1.10	A26NSM4-84***	\$ 1,410.00	ACE	3.59
A260SH2-84**	\$ 20,169.00	PWAE	3.81	A26H2-84**	\$ 2,871.00	PWAE	3.81	A26NSM7-84***	\$ 3,105.00	AXE	3.59
A260SH3-84**	\$ 20,169.00	PWAE	3.81	A26H3-84**	\$ 2,871.00	PWAE	3.81	A26NSMP-84***	\$ 1,193.00	ACE	3.59
A260SHX-84**	\$ 26,100.00	PWAE	3.81	A26H4-84**	\$ 3,051.00	PWAE	3.81	A26NSMX-84***	\$ 2,000.00	ACE	3.59
A260SM1-84***	\$ 8,160.00	ACE	3.56	A26HX-84**	\$ 3,638.00	PWAE	3.81	A26NSN1-84*	\$ 968.00	ACE	3.50
A260SM2-84***	\$ 10,155.00	ACE	3.57	A26M-30-01-84	\$ 405.00	AA	1.3	A26NSN2-84*	\$ 1,148.00	ACE	3.51
A260SM3-84***	\$ 10,155.00	ACE	3.56	A26M-30-10-84	\$ 405.00	AA	1.3	A26NSN3-84*	\$ 1,148.00	ACE	3.50
A260SM4-84***	\$ 10,950.00	ACE	3.57	A26N1-30-10-84	\$ 183.00	AA	1.11	A26NSN4-84*	\$ 1,448.00	ACE	3.51
A260SMP-84***	\$ 10,650.00	ACE	3.57	A26N1M-10-84	\$ 405.00	AA	1.11	A26NSNP-84*	\$ 1,088.00	ACE	3.51
A260SMX-84***	\$ 17,250.00	ACE	3.57	A26N1R-10-84	\$ 480.00	AA	1.11	A26NSNX-84*	\$ 1,780.00	ACE	3.51
A260SN1-84*	\$ 6,090.00	ACE	3.50	A26N1S-84*	\$ 294.00	AA	3.14	A26NSP-84*	\$ 443.00	AAE	3.15
A260SN2-84*	\$ 8,085.00	ACE	3.51	A26N1SA-84*	\$ 4,341.00	RVA	3.74	A26NSR1-84*	\$ 810.00	AAE	3.18
A260SN3-84*	\$ 8,085.00	ACE	3.50	A26N1SG-84**	\$ 3,038.00	WDA	3.76	A26NSR2-84*	\$ 900.00	AAE	3.19
A260SN4-84*	\$ 9,600.00	ACE	3.51	A26N1SH-84**	\$ 1,917.00	PWA	3.80	A26NSR3-84*	\$ 900.00	AAE	3.19
A260SNP-84*	\$ 8,750.00	ACE	3.51	A26N1SP-84*	\$ 443.00	AAE	3.17	A26NSR4-84*	\$ 1,125.00	AAE	3.19
A260SNX-84*	\$ 16,500.00	ACE	3.51	A26N1SR-84*	\$ 503.00	AA	3.18	A26NSRF1-84*6A	\$ 1,425.00	ACE	3.54
A260SP-84*	\$ 4,200.00	AEAE	3.15	A26N1SS-84*	\$ 294.00	AA	3.16	A26NSRF1-84*6B	\$ 1,425.00	ACE	3.54
A260SR-84*	\$ 5,436.00	AEA	3.18	A26N1SS1-84*	\$ 405.00	AAE	3.16	A26NSRF2-84*6A	\$ 1,635.00	ACE	3.55
A260SR1-84*	\$ 7,615.00	AEAE	3.18	A26N1SS2-84*	\$ 465.00	AAE	3.17	A26NSRF2-84*6B	\$ 1,635.00	ACE	3.55
A260SR2-84*	\$ 8,355.00	AEAE	3.19	A26N1SS3-84*	\$ 465.00	AAE	3.17	A26NSRF3-84*6A	\$ 1,635.00	ACE	3.54

A26NSRF3-84*6B – A300SRFX-84*6E

Alphanumeric

0

Catalog number	List price	Discount schedule	Page number	Catalog number	List price	Discount schedule	Page number	Catalog number	List price	Discount schedule	Page number
A26NSRF3-84*6B	\$ 1,635.00	ACE	3.54	A26SH1-84**	\$ 1,971.00	PWAE	3.80	A26SYX-84**	\$ 6,450.00	WDAE	3.79
A26NSRF4-84*6A	\$ 1,763.00	ACE	3.55	A26SM1-84***	\$ 1,073.00	ACE	3.56	A30-30-01-84	\$ 252.00	AA	1.3
A26NSRF4-84-6B	\$ 1,763.00	ACE	3.55	A26SM2-84***	\$ 1,253.00	ACE	3.57	A30-30-10-84	\$ 252.00	AA	1.3
A26NSRFP-84*6A	\$ 1,560.00	ACE	3.55	A26SM3-84***	\$ 1,253.00	ACE	3.56	A300-30-11-84	\$ 1,875.00	AEA	1.3
A26NSRFP-84*6B	\$ 1,560.00	ACE	3.55	A26SM4-84***	\$ 1,410.00	ACE	3.57	A300M-30-AA-84	\$ 5,460.00	AEA	1.3
A26NSRFX-84*6A	\$ 2,270.00	ACE	3.55	A26SM7-84***	\$ 3,105.00	AXE	3.57	A300R-30-11-84	\$ 5,475.00	AEA	1.3
A26NSRFX-84*6B	\$ 2,270.00	ACE	3.55	A26SMP-84***	\$ 1,193.00	ACE	3.57	A300S-84*	\$ 2,890.00	AEA	3.14
A26NSRM1-84***	\$ 1,478.00	ACE	3.62	A26SMX-84***	\$ 2,000.00	ACE	3.57	A300S1-84*	\$ 4,125.00	AAE	3.14
A26NSRM2-84***	\$ 1,658.00	ACE	3.63	A26SN1-84*	\$ 968.00	ACE	3.50	A300S2-84*	\$ 4,875.00	AEAE	3.15
A26NSRM3-84***	\$ 1,658.00	ACE	3.62	A26SN2-84*	\$ 1,148.00	ACE	3.51	A300S3-84*	\$ 4,875.00	AAE	3.14
A26NSRM4-84***	\$ 1,800.00	ACE	3.63	A26SN3-84*	\$ 1,148.00	ACE	3.50	A300S4-84*	\$ 5,400.00	AEAE	3.15
A26NSRMP-84***	\$ 1,703.00	ACE	3.63	A26SN4-84*	\$ 1,448.00	ACE	3.51	A300S7-84*	\$ 11,965.00	AXE	3.15
A26NSRMX-84***	\$ 2,405.00	ACE	3.63	A26SNP-84*	\$ 1,088.00	ACE	3.51	A300SA-84*	\$ 24,042.00	RVA	3.74
A26NSRP-84*	\$ 960.00	AAE	3.19	A26SNX-84*	\$ 1,790.00	ACE	3.51	A300SA1-84*	\$ 26,034.00	RVAE	3.74
A26NSRX-84*	\$ 1,725.00	AAE	3.19	A26SP-84*	\$ 443.00	AAE	3.15	A300SA2-84*	\$ 28,391.00	RVAE	3.75
A26NST1-84*1*	\$ 1,097.00	AAE	3.20	A26SR-84*	\$ 503.00	AA	3.18	A300SA3-84*	\$ 28,391.00	RVAE	3.75
A26NST1-84*2*	\$ 882.00	AAE	3.22	A26SR1-84*	\$ 810.00	AAE	3.18	A300SA4-84*	\$ 31,184.00	RVAE	3.75
A26NST2-84*1*	\$ 1,187.00	AAE	3.21	A26SR2-84*	\$ 900.00	AAE	3.19	A300SAX-84*	\$ 33,000.00	RVAE	3.75
A26NST2-84*2*	\$ 972.00	AAE	3.23	A26SR3-84*	\$ 900.00	AAE	3.19	A300SF1-84*6E	\$ 8,100.00	ACE	3.52
A26NST3-84*1*	\$ 1,187.00	AAE	3.21	A26SR4-84*	\$ 1,125.00	AAE	3.19	A300SF2-84*6E	\$ 10,350.00	ACE	3.53
A26NST3-84*2*	\$ 972.00	AAE	3.23	A26SRF1-84*6B	\$ 1,425.00	ACE	3.54	A300SF3-84*6E	\$ 10,350.00	ACE	3.52
A26NST4-84*1*	\$ 1,515.00	AAE	3.21	A26SRF2-84*6B	\$ 1,635.00	ACE	3.55	A300SF4-84*6E	\$ 12,000.00	ACE	3.53
A26NST4-84*2*	\$ 1,200.00	AAE	3.23	A26SRF3-84*6B	\$ 1,635.00	ACE	3.54	A300SFP-84*6E	\$ 11,200.00	ACE	3.53
A26NSTP-84*1*	\$ 1,247.00	AAE	3.21	A26SRF4-84*6B	\$ 1,763.00	ACE	3.55	A300SFX-84*6E	\$ 22,350.00	ACE	3.53
A26NSTP-84*2*	\$ 1,032.00	AAE	3.23	A26SRFP-84*6B	\$ 1,560.00	ACE	3.55	A300SG-84**	\$ 25,950.00	WDA	3.76
A26NSTX-84*1*	\$ 2,012.00	AAE	3.21	A26SRFX-84*6B	\$ 2,270.00	ACE	3.55	A300SG1-84**	\$ 27,900.00	WDAE	3.76
A26NSTX-84*2*	\$ 1,797.00	AAE	3.23	A26SRM1-84***	\$ 1,478.00	ACE	3.60	A300SG2-84**	\$ 30,383.00	WDAE	3.77
A26NSX-84*	\$ 831.00	AAE	3.15	A26SRM2-84***	\$ 1,658.00	ACE	3.61	A300SG3-84**	\$ 30,383.00	WDAE	3.77
A26NSY1-84**	\$ 4,721.00	WDAE	3.78	A26SRM3-84***	\$ 1,658.00	ACE	3.60	A300SG4-84**	\$ 31,538.00	WDAE	3.77
A26NSY2-84**	\$ 5,621.00	WDAE	3.79	A26SRM4-84***	\$ 1,800.00	ACE	3.61	A300SGX-84**	\$ 35,475.00	WDAE	3.77
A26NSY3-84**	\$ 5,621.00	WDAE	3.79	A26SRMP-84***	\$ 1,703.00	ACE	3.61	A300SH-84**	\$ 30,591.00	PWA	3.80
A26NSY4-84**	\$ 5,801.00	WDAE	3.79	A26SRMX-84***	\$ 2,405.00	ACE	3.61	A300SH1-84**	\$ 31,590.00	PWAE	3.80
A26NSYX-84**	\$ 6,450.00	WDAE	3.79	A26SRP-84*	\$ 960.00	AAE	3.19	A300SH2-84**	\$ 34,020.00	PWAE	3.81
A26R-30-01-84	\$ 480.00	AA	1.3	A26SRX-84*	\$ 1,725.00	AAE	3.19	A300SH3-84**	\$ 34,020.00	PWAE	3.81
A26R-30-10-84	\$ 480.00	AA	1.3	A26SS-84*	\$ 294.00	AA	3.16	A300SH4-84**	\$ 36,720.00	PWAE	3.81
A26S-84*	\$ 294.00	AA	3.14	A26SS1-84*	\$ 405.00	AAE	3.16	A300SHX-84**	\$ 38,225.00	PWAE	3.81
A26S1-84*	\$ 405.00	AAE	3.14	A26SS2-84*	\$ 465.00	AAE	3.17	A300SM1-84***	\$ 8,850.00	ACE	3.56
A26S2-84*	\$ 465.00	AAE	3.15	A26SS3-84*	\$ 465.00	AAE	3.17	A300SM2-84***	\$ 10,650.00	ACE	3.57
A26S3-84*	\$ 465.00	AAE	3.14	A26SS4-84*	\$ 630.00	AAE	3.17	A300SM3-84***	\$ 10,650.00	ACE	3.56
A26S4-84*	\$ 630.00	AAE	3.15	A26SSP-84*	\$ 443.00	AAE	3.17	A300SM4-84***	\$ 12,000.00	ACE	3.57
A26S7-84*	\$ 1,680.00	AXE	3.15	A26SSX-84*	\$ 831.00	AAE	3.17	A300SMP-84***	\$ 11,500.00	ACE	3.57
A26SA-84*	\$ 4,341.00	RVA	3.74	A26ST-84*1*	\$ 752.00	AA	3.20	A300SMX-84***	\$ 22,800.00	ACE	3.57
A26SA1-84*	\$ 5,457.00	RVAE	3.74	A26ST-84*2*	\$ 552.00	AA	3.22	A300SN1-84*	\$ 7,080.00	ACE	3.50
A26SA2-84*	\$ 6,177.00	RVAE	3.75	A26ST1-84*1*	\$ 1,097.00	AAE	3.20	A300SN2-84*	\$ 8,850.00	ACE	3.51
A26SA3-84*	\$ 6,177.00	RVAE	3.75	A26ST1-84*2*	\$ 882.00	AAE	3.22	A300SN3-84*	\$ 8,850.00	ACE	3.50
A26SA4-84*	\$ 7,347.00	RVAE	3.75	A26ST2-84*1*	\$ 1,187.00	AAE	3.21	A300SN4-84*	\$ 10,350.00	ACE	3.51
A26SAX-84*	\$ 8,888.00	RVAE	3.75	A26ST2-84*2*	\$ 972.00	AAE	3.23	A300SNP-84*	\$ 9,750.00	ACE	3.51
A26SF1-84*6B	\$ 1,020.00	ACE	3.52	A26ST3-84*1*	\$ 1,187.00	AAE	3.21	A300SNX-84*	\$ 21,000.00	ACE	3.51
A26SF2-84*6B	\$ 1,230.00	ACE	3.53	A26ST3-84*2*	\$ 972.00	AAE	3.23	A300SP-84*	\$ 4,425.00	AEAE	3.15
A26SF3-84*6B	\$ 1,230.00	ACE	3.52	A26ST4-84*1*	\$ 1,515.00	AAE	3.21	A300SR-84*	\$ 6,190.00	AEA	3.18
A26SF4-84*6B	\$ 1,530.00	ACE	3.53	A26ST4-84*2*	\$ 1,200.00	AAE	3.23	A300SR1-84*	\$ 8,070.00	AEAE	3.18
A26SFP-84*6B	\$ 1,148.00	ACE	3.53	A26STP-84*1*	\$ 1,247.00	AAE	3.21	A300SR2-84*	\$ 8,835.00	AEAE	3.19
A26SFX-84*6B	\$ 1,965.00	ACE	3.53	A26STP-84*2*	\$ 1,032.00	AAE	3.23	A300SR3-84*	\$ 8,835.00	AEAE	3.19
A26SG-84**	\$ 3,038.00	WDA	3.76	A26STX-84*1*	\$ 2,012.00	AAE	3.21	A300SR4-84*	\$ 10,015.00	AEAE	3.19
A26SG1-84**	\$ 3,092.00	WDAE	3.76	A26STX-84*2*	\$ 1,797.00	AAE	3.23	A300SRF1-84*6E	\$ 13,560.00	ACE	3.54
A26SG2-84**	\$ 3,992.00	WDAE	3.77	A26SX-84*	\$ 831.00	AAE	3.15	A300SRF2-84*6E	\$ 15,810.00	ACE	3.55
A26SG3-84**	\$ 3,992.00	WDAE	3.77	A26SY-84**	\$ 4,667.00	WDA	3.78	A300SRF3-84*6E	\$ 15,810.00	ACE	3.54
A26SG4-84**	\$ 4,172.00	WDAE	3.77	A26SY2-84**	\$ 5,621.00	WDAE	3.79	A300SRF4-84*6E	\$ 16,530.00	ACE	3.55
A26SGX-84**	\$ 4,800.00	WDAE	3.77	A26SY3-84**	\$ 5,621.00	WDAE	3.79	A300SRFP-84*6E	\$ 16,200.00	ACE	3.55
A26SH-84**	\$ 1,917.00	PWA	3.80	A26SY4-84**	\$ 5,801.00	WDAE	3.79	A300SRFX-84*6E	\$ 27,810.00	ACE	3.55

A300SRM1-84*** – A400ST1-70*1*

Catalog number	List price	Discount schedule	Page number	Catalog number	List price	Discount schedule	Page number	Catalog number	List price	Discount schedule	Page number
A300SRM1-84***	\$ 11,115.00	ACE	3.60	A30SM2-84***	\$ 1,335.00	ACE	3.57	A40-30-01-84	\$ 297.00	AA	1.3
A300SRM2-84***	\$ 16,110.00	ACE	3.61	A30SM3-84***	\$ 1,335.00	ACE	3.56	A40-30-10-84	\$ 297.00	AA	1.3
A300SRM3-84***	\$ 16,110.00	ACE	3.60	A30SM4-84***	\$ 1,500.00	ACE	3.57	A400S-70*	\$ 4,125.00	AEA	3.14
A300SRM4-84***	\$ 18,150.00	ACE	3.61	A30SM7-84***	\$ 3,480.00	AXE	3.57	A400S1-70*	\$ 7,857.00	AEE	3.14
A300SRMP-84***	\$ 17,600.00	ACE	3.61	A30SMP-84***	\$ 1,275.00	ACE	3.57	A400S2-70*	\$ 8,625.00	AEAE	3.15
A300SRMX-84***	\$ 28,260.00	ACE	3.61	A30SMX-84***	\$ 2,330.00	ACE	3.57	A400S3-70*	\$ 8,625.00	AEE	3.14
A300SRP-84*	\$ 7,861.00	AEAE	3.19	A30SN1-84*	\$ 1,050.00	ACE	3.50	A400S4-70*	\$ 9,000.00	AEAE	3.15
A300SRX-84*	\$ 12,055.00	AEAE	3.19	A30SN2-84*	\$ 1,230.00	ACE	3.51	A400SA-70*	\$ 30,996.00	RVA	3.74
A300ST-84*1*	\$ 9,171.00	AEA	3.20	A30SN3-84*	\$ 1,230.00	ACE	3.50	A400SA1-70*	\$ 32,981.00	RVAE	3.74
A300ST-84*2*	\$ 6,340.00	AEA	3.22	A30SN4-84*	\$ 1,613.00	ACE	3.51	A400SA2-70*	\$ 35,247.00	RVAE	3.75
A300ST1-84*1*	\$ 11,391.00	AEAE	3.20	A30SNP-84*	\$ 1,170.00	ACE	3.51	A400SA3-70*	\$ 35,247.00	RVAE	3.75
A300ST1-84*2*	\$ 8,142.00	AEAE	3.22	A30SNX-84*	\$ 2,110.00	ACE	3.51	A400SA4-70*	\$ 38,807.00	RVAE	3.75
A300ST2-84*1*	\$ 12,155.00	AEAE	3.21	A30SP-84*	\$ 510.00	AEE	3.15	A400SAX-70*	\$ 41,175.00	RVAE	3.75
A300ST2-84*2*	\$ 8,905.00	AEAE	3.23	A30SR-84*	\$ 675.00	AA	3.18	A400SF1-70*6F	\$ 11,895.00	ACE	3.52
A300ST3-84*1*	\$ 12,155.00	AEAE	3.21	A30SR1-84*	\$ 953.00	AEE	3.18	A400SF2-70*6F	\$ 12,600.00	ACE	3.53
A300ST3-84*2*	\$ 8,905.00	AEAE	3.23	A30SR2-84*	\$ 1,043.00	AAE	3.19	A400SF3-70*6F	\$ 12,600.00	ACE	3.52
A300ST4-84*1*	\$ 13,425.00	AEAE	3.21	A30SR3-84*	\$ 1,043.00	AAE	3.19	A400SF4-70*6F	\$ 14,663.00	ACE	3.53
A300ST4-84*2*	\$ 9,750.00	AEAE	3.23	A30SR4-84*	\$ 1,313.00	AAE	3.19	A400SFX-70*6F	\$ 26,400.00	ACE	3.53
A300STP-84*1*	\$ 11,586.00	AEAE	3.21	A30SRF1-84*6B	\$ 1,643.00	ACE	3.54	A400SG-70**	\$ 36,000.00	WDA	3.76
A300STP-84*2*	\$ 7,990.00	AEAE	3.23	A30SRF2-84*6B	\$ 1,860.00	ACE	3.55	A400SG1-70**	\$ 38,916.00	WDAE	3.76
A300STX-84*1*	\$ 16,275.00	AEAE	3.21	A30SRF3-84*6B	\$ 1,860.00	ACE	3.54	A400SG2-70**	\$ 41,150.00	WDAE	3.77
A300STX-84*2*	\$ 13,025.00	AEAE	3.23	A30SRF4-84*6B	\$ 1,988.00	ACE	3.55	A400SG3-70**	\$ 41,150.00	WDAE	3.77
A300SX-84*	\$ 6,040.00	AEAE	3.15	A30SRFP-84*6B	\$ 1,778.00	ACE	3.55	A400SG4-70**	\$ 42,816.00	WDAE	3.77
A300SY-84**	\$ 32,063.00	WDA	3.78	A30SRFX-84*6B	\$ 2,745.00	ACE	3.55	A400SGX-70**	\$ 46,575.00	WDAE	3.77
A300SY1-84**	\$ 37,061.00	WDAE	3.78	A30SRM1-84***	\$ 1,703.00	ACE	3.60	A400SH-70**	\$ 36,000.00	PWA	3.80
A300SY2-84**	\$ 34,991.00	WDAE	3.79	A30SRM2-84***	\$ 1,883.00	ACE	3.61	A400SH1-70**	\$ 37,089.00	PWAE	3.80
A300SY3-84**	\$ 34,991.00	WDAE	3.79	A30SRM3-84***	\$ 1,883.00	ACE	3.60	A400SH2-70**	\$ 41,589.00	PWAE	3.81
A300SY4-84**	\$ 37,691.00	WDAE	3.79	A30SRM4-84***	\$ 2,100.00	ACE	3.61	A400SH3-70**	\$ 41,589.00	PWAE	3.81
A300SYX-84**	\$ 40,688.00	WDAE	3.79	A30SRMP-84***	\$ 1,853.00	ACE	3.61	A400SH4-70**	\$ 42,552.00	PWAE	3.81
A300W-20-11-84	\$ 1,750.00	AEA	1.116	A30SRMX-84***	\$ 2,878.00	ACE	3.61	A400SHX-70**	\$ 45,263.00	PWAE	3.81
A300W-30-11-84	\$ 1,875.00	AEA	1.116	A30SRP-84*	\$ 1,103.00	AAE	3.19	A400SM1-70***	\$ 12,450.00	ACE	3.56
A30M-30-01-84	\$ 548.00	AA	1.3	A30SRX-84*	\$ 1,868.00	AAE	3.19	A400SM2-70***	\$ 12,990.00	ACE	3.57
A30M-30-10-84	\$ 548.00	AA	1.3	A30SS-84*	\$ 372.00	AA	3.16	A400SM3-70***	\$ 12,990.00	ACE	3.56
A30R-30-01-84	\$ 623.00	AA	1.3	A30SS1-84*	\$ 473.00	AAE	3.16	A400SM4-70***	\$ 13,800.00	ACE	3.57
A30R-30-10-84	\$ 623.00	AA	1.3	A30SS2-84*	\$ 533.00	AAE	3.17	A400SMX-70***	\$ 26,850.00	ACE	3.57
A30S-84*	\$ 365.00	AA	3.14	A30SS3-84*	\$ 533.00	AAE	3.17	A400SN1-70*	\$ 11,250.00	ACE	3.50
A30S1-84*	\$ 473.00	AAE	3.14	A30SS4-84*	\$ 690.00	AAE	3.17	A400SN2-70*	\$ 12,285.00	ACE	3.51
A30S2-84*	\$ 533.00	AAE	3.15	A30SSP-84*	\$ 510.00	AAE	3.17	A400SN3-70*	\$ 12,285.00	ACE	3.50
A30S3-84*	\$ 533.00	AAE	3.14	A30SSX-84*	\$ 885.00	AAE	3.17	A400SN4-70*	\$ 13,800.00	ACE	3.51
A30S4-84*	\$ 690.00	AAE	3.15	A30ST-84*1*	\$ 1,038.00	AA	3.20	A400SNX-70*	\$ 25,800.00	ACE	3.51
A30S7-84*	\$ 2,040.00	AXE	3.15	A30ST-84*2*	\$ 747.00	AA	3.22	A400SR-70*	\$ 7,980.00	AEA	3.18
A30SF1-84*6B	\$ 1,095.00	ACE	3.52	A30ST1-84*1*	\$ 1,316.00	AAE	3.20	A400SR1-70*	\$ 15,450.00	AEAE	3.18
A30SF2-84*6B	\$ 1,313.00	ACE	3.53	A30ST1-84*2*	\$ 1,025.00	AAE	3.22	A400SR2-70*	\$ 16,125.00	AEAE	3.19
A30SF3-84*6B	\$ 1,313.00	ACE	3.52	A30ST2-84*1*	\$ 1,406.00	AAE	3.21	A400SR3-70*	\$ 16,125.00	AEAE	3.19
A30SF4-84*6B	\$ 1,688.00	ACE	3.53	A30ST2-84*2*	\$ 1,115.00	AAE	3.23	A400SR4-70*	\$ 17,100.00	AEAE	3.19
A30SFP-84*6B	\$ 1,230.00	ACE	3.53	A30ST3-84*1*	\$ 1,406.00	AAE	3.21	A400SRF1-70*6F	\$ 17,880.00	ACE	3.54
A30SFX-84*6B	\$ 2,295.00	ACE	3.53	A30ST3-84*2*	\$ 1,115.00	AAE	3.23	A400SRF2-70*6F	\$ 18,585.00	ACE	3.55
A30SG-84**	\$ 3,347.00	WDA	3.76	A30ST4-84*1*	\$ 1,688.00	AAE	3.21	A400SRF3-70*6F	\$ 18,585.00	ACE	3.54
A30SG1-84**	\$ 3,392.00	WDAE	3.76	A30ST4-84*2*	\$ 1,388.00	AAE	3.23	A400SRF4-70*6F	\$ 20,625.00	ACE	3.55
A30SG2-84**	\$ 4,335.00	WDAE	3.77	A30STP-84*1*	\$ 1,466.00	AAE	3.21	A400SRFP-70*6F	\$ 20,000.00	ACE	3.55
A30SG3-84**	\$ 4,335.00	WDAE	3.77	A30STP-84*2*	\$ 1,175.00	AAE	3.23	A400SRFX-70*6F	\$ 32,385.00	ACE	3.55
A30SG4-84**	\$ 4,485.00	WDAE	3.77	A30STX-84*1*	\$ 2,231.00	AAE	3.21	A400SRM1-70***	\$ 18,435.00	ACE	3.60
A30SGX-84**	\$ 5,138.00	WDAE	3.77	A30STX-84*2*	\$ 1,940.00	AAE	3.23	A400SRM2-70***	\$ 18,975.00	ACE	3.61
A30SH-84**	\$ 2,097.00	PWA	3.80	A30SX-84*	\$ 885.00	AAE	3.15	A400SRM3-70***	\$ 18,975.00	ACE	3.60
A30SH1-84**	\$ 2,151.00	PWAE	3.80	A30SY-84**	\$ 4,967.00	WDA	3.78	A400SRM4-70***	\$ 21,000.00	ACE	3.61
A30SH2-84**	\$ 3,075.00	PWAE	3.81	A30SY1-84**	\$ 5,021.00	WDAE	3.78	A400SRMX-70***	\$ 32,835.00	ACE	3.61
A30SH3-84**	\$ 3,075.00	PWAE	3.81	A30SY2-84**	\$ 5,921.00	WDAE	3.79	A400SRX-70*	\$ 20,690.00	AEAE	3.19
A30SH4-84**	\$ 3,233.00	PWAE	3.81	A30SY3-84**	\$ 5,921.00	WDAE	3.79	A400ST-70*1*	\$ 10,100.00	AEA	3.20
A30SHX-84**	\$ 3,825.00	PWAE	3.81	A30SY4-84**	\$ 6,101.00	WDAE	3.79	A400ST-70*2*	\$ 6,855.00	AEA	3.22
A30SM1-84***	\$ 1,155.00	ACE	3.56	A30SYX-84**	\$ 6,788.00	WDAE	3.79	A400ST1-70*1*	\$ 19,460.00	AEAE	3.20

A400ST1-70*2* – A460NSRX-70*

Alphanumeric

Catalog number	List price	Discount schedule	Page number	Catalog number	List price	Discount schedule	Page number	Catalog number	List price	Discount schedule	Page number
A400ST1-70*2*	\$ 15,522.00	AEAE	3.22	A40SN4-84*	\$ 1,800.00	ACE	3.51	A460N6SY-70**	\$ 50,522.00	WDA	3.78
A400ST2-70*1*	\$ 20,135.00	AEAE	3.21	A40SNP-84*	\$ 1,275.00	ACE	3.51	A460NS1-70*	\$ 9,375.00	AAE	3.14
A400ST2-70*2*	\$ 16,197.00	AEAE	3.23	A40SNX-84*	\$ 2,500.00	ACE	3.51	A460NS2-70*	\$ 10,380.00	AEAE	3.15
A400ST3-70*1*	\$ 20,135.00	AEAE	3.21	A40SP-84*	\$ 555.00	AAE	3.15	A460NS3-70*	\$ 9,435.00	AAE	3.14
A400ST3-70*2*	\$ 16,197.00	AEAE	3.23	A40SR-84*	\$ 765.00	AA	3.18	A460NS4-70*	\$ 10,800.00	AEAE	3.15
A400ST4-70*1*	\$ 21,600.00	AEAE	3.21	A40SR1-84*	\$ 1,080.00	AAE	3.18	A460NSA1-70*	\$ 39,182.00	RVAE	3.74
A400ST4-70*2*	\$ 17,100.00	AEAE	3.23	A40SR2-84*	\$ 1,305.00	AAE	3.19	A460NSA2-70*	\$ 42,557.00	RVAE	3.75
A400STX-70*1*	\$ 24,700.00	AEAE	3.21	A40SR3-84*	\$ 1,305.00	AAE	3.19	A460NSA3-70*	\$ 42,557.00	RVAE	3.75
A400STX-70*2*	\$ 20,760.00	AEAE	3.23	A40SR4-84*	\$ 1,500.00	AAE	3.19	A460NSA4-70*	\$ 45,932.00	RVAE	3.75
A400SX-70*	\$ 9,855.00	AEAE	3.15	A40SRF1-84*6B	\$ 1,860.00	ACE	3.54	A460NSAX-70*	\$ 50,700.00	RVAE	3.75
A400SY-70**	\$ 39,863.00	WDA	3.78	A40SRF2-84*6B	\$ 2,093.00	ACE	3.55	A460NSF1-70*6F	\$ 16,890.00	ACE	3.52
A400SY1-70**	\$ 43,350.00	WDAE	3.78	A40SRF3-84*6B	\$ 2,093.00	ACE	3.54	A460NSF1-70*6G	\$ 18,750.00	ACE	3.52
A400SY2-70**	\$ 41,250.00	WDAE	3.79	A40SRF4-84*6B	\$ 2,213.00	ACE	3.55	A460NSF2-70*6F	\$ 19,560.00	ACE	3.53
A400SY3-70**	\$ 41,250.00	WDAE	3.79	A40SRFP-84*6B	\$ 1,995.00	ACE	3.55	A460NSF2-70*6G	\$ 21,600.00	ACE	3.53
A400SY4-70**	\$ 45,330.00	WDAE	3.79	A40SRFX-84*6B	\$ 3,260.00	ACE	3.55	A460NSF3-70*6F	\$ 19,560.00	ACE	3.52
A400SYX-70**	\$ 48,675.00	WDAE	3.79	A40SRM1-84***	\$ 1,935.00	ACE	3.60	A460NSF3-70*6G	\$ 21,600.00	ACE	3.52
A40M-30-01-84	\$ 639.00	AA	1.3	A40SRM2-84***	\$ 2,115.00	ACE	3.61	A460NSF4-70*6F	\$ 21,360.00	ACE	3.53
A40M-30-10-84	\$ 639.00	AA	1.3	A40SRM3-84***	\$ 2,115.00	ACE	3.60	A460NSF4-70*6G	\$ 23,400.00	ACE	3.53
A40R-30-01-84	\$ 750.00	AA	1.3	A40SRM4-84***	\$ 2,438.00	ACE	3.61	A460NSFX-70*6F	\$ 26,955.00	ACE	3.53
A40R-30-10-84	\$ 750.00	AA	1.3	A40SRMP-84***	\$ 2,085.00	ACE	3.61	A460NSFX-70*6G	\$ 28,995.00	ACE	3.53
A40S-84*	\$ 423.00	AA	3.14	A40SRMX-84***	\$ 3,395.00	ACE	3.61	A460NSG1-70**	\$ 42,710.00	WDAE	3.76
A40S1-84*	\$ 525.00	AAE	3.14	A40SRP-84*	\$ 1,230.00	AAE	3.19	A460NSG2-70**	\$ 46,085.00	WDAE	3.77
A40S2-84*	\$ 578.00	AAE	3.15	A40SRX-84*	\$ 2,010.00	AAE	3.19	A460NSG3-70**	\$ 46,085.00	WDAE	3.77
A40S3-84*	\$ 578.00	AAE	3.14	A40SS-84*	\$ 423.00	AA	3.16	A460NSG4-70**	\$ 49,460.00	WDAE	3.77
A40S4-84*	\$ 1,050.00	AAE	3.15	A40SS1-84*	\$ 525.00	AAE	3.16	A460NSGX-70**	\$ 51,900.00	WDAE	3.77
A40S7-84*	\$ 2,410.00	AXE	3.15	A40SS2-84*	\$ 578.00	AAE	3.17	A460NSH1-70**	\$ 42,938.00	PWAE	3.80
A40SA-84*	\$ 4,698.00	RVA	3.74	A40SS3-84*	\$ 578.00	AAE	3.17	A460NSH2-70**	\$ 47,438.00	PWAE	3.81
A40SA1-84*	\$ 5,814.00	RVAE	3.74	A40SS4-84*	\$ 1,050.00	AAE	3.17	A460NSH3-70**	\$ 47,438.00	PWAE	3.81
A40SA2-84*	\$ 6,549.00	RVAE	3.75	A40SSP-84*	\$ 555.00	AAE	3.17	A460NSH4-70**	\$ 48,401.00	PWAE	3.81
A40SA3-84*	\$ 6,549.00	RVAE	3.75	A40SSX-84*	\$ 1,275.00	AAE	3.17	A460NSHX-70**	\$ 49,919.00	PWAE	3.81
A40SA4-84*	\$ 7,719.00	RVAE	3.75	A40ST-84*1*	\$ 1,259.00	AA	3.20	A460NSM1-70***	\$ 19,350.00	ACE	3.58
A40SAX-84*	\$ 9,375.00	RVAE	3.75	A40ST-84*2*	\$ 834.00	AA	3.22	A460NSM2-70***	\$ 21,150.00	ACE	3.59
A40SF1-84*6B	\$ 1,185.00	ACE	3.52	A40ST1-84*1*	\$ 1,577.00	AAE	3.20	A460NSM3-70***	\$ 21,150.00	ACE	3.58
A40SF2-84*6B	\$ 1,418.00	ACE	3.53	A40ST1-84*2*	\$ 1,152.00	AAE	3.22	A460NSM4-70***	\$ 22,500.00	ACE	3.59
A40SF3-84*6B	\$ 1,418.00	ACE	3.52	A40ST2-84*1*	\$ 1,802.00	AAE	3.21	A460NSMX-70***	\$ 28,995.00	ACE	3.59
A40SF4-84*6B	\$ 1,898.00	ACE	3.53	A40ST2-84*2*	\$ 1,377.00	AAE	3.23	A460NSN1-70*	\$ 17,100.00	ACE	3.50
A40SFP-84*6B	\$ 1,335.00	ACE	3.53	A40ST3-84*1*	\$ 1,802.00	AAE	3.21	A460NSN2-70*	\$ 18,900.00	ACE	3.51
A40SFX-84*6B	\$ 2,685.00	ACE	3.53	A40ST3-84*2*	\$ 1,377.00	AAE	3.23	A460NSN3-70*	\$ 18,900.00	ACE	3.50
A40SG-84**	\$ 3,450.00	WDA	3.76	A40ST4-84*1*	\$ 2,100.00	AAE	3.21	A460NSN4-70*	\$ 20,700.00	ACE	3.51
A40SG1-84**	\$ 3,494.00	WDAE	3.76	A40ST4-84*2*	\$ 1,545.00	AAE	3.23	A460NSNX-70*	\$ 27,900.00	ACE	3.51
A40SG2-84**	\$ 4,425.00	WDAE	3.77	A40STP-84*1*	\$ 1,727.00	AAE	3.21	A460NSR1-70*	\$ 22,482.00	AEAE	3.18
A40SG3-84**	\$ 4,425.00	WDAE	3.77	A40STP-84*2*	\$ 1,302.00	AAE	3.23	A460NSR2-70*	\$ 23,230.00	AEAE	3.19
A40SG4-84**	\$ 4,575.00	WDAE	3.77	A40STX-84*1*	\$ 2,507.00	AAE	3.21	A460NSR3-70*	\$ 23,230.00	AEAE	3.19
A40SGX-84**	\$ 5,400.00	WDAE	3.77	A40STX-84*2*	\$ 2,082.00	AAE	3.23	A460NSR4-70*	\$ 23,625.00	AEAE	3.19
A40SH-84**	\$ 2,586.00	PWA	3.80	A40SX-84*	\$ 1,275.00	AAE	3.15	A460NSRF1-70*6F	\$ 29,175.00	ACE	3.54
A40SH1-84**	\$ 2,643.00	PWAE	3.80	A40SY-84**	\$ 5,198.00	WDA	3.78	A460NSRF1-70*6G	\$ 31,035.00	ACE	3.54
A40SH2-84**	\$ 3,543.00	PWAE	3.81	A40SY1-84**	\$ 5,342.00	WDAE	3.78	A460NSRF2-70*6F	\$ 32,025.00	ACE	3.55
A40SH3-84**	\$ 3,543.00	PWAE	3.81	A40SY2-84**	\$ 6,467.00	WDAE	3.79	A460NSRF2-70*6G	\$ 33,885.00	ACE	3.55
A40SH4-84**	\$ 3,723.00	PWAE	3.81	A40SY3-84**	\$ 6,467.00	WDAE	3.79	A460NSRF3-70*6F	\$ 32,025.00	ACE	3.54
A40SHX-84**	\$ 4,313.00	PWAE	3.81	A40SY4-84**	\$ 6,557.00	WDAE	3.79	A460NSRF3-70*6G	\$ 33,885.00	ACE	3.54
A40SM1-84***	\$ 1,260.00	ACE	3.56	A40SYX-84**	\$ 7,275.00	WDAE	3.79	A460NSRF4-70*6F	\$ 33,540.00	ACE	3.55
A40SM2-84***	\$ 1,440.00	ACE	3.57	A45-22-00-84	\$ 360.00	AA	1.13	A460NSRF4-70*6G	\$ 35,400.00	ACE	3.55
A40SM3-84***	\$ 1,440.00	ACE	3.56	A45-40-00-84	\$ 360.00	AA	1.13	A460NSRFX-70*6F	\$ 39,420.00	ACE	3.55
A40SM4-84***	\$ 1,635.00	ACE	3.57	A460N6S-70*	\$ 5,700.00	AEA	3.14	A460NSRFX-70*6G	\$ 41,280.00	ACE	3.55
A40SM7-84***	\$ 3,860.00	AXE	3.57	A460N6SA-70*	\$ 35,978.00	RVA	3.74	A460NSRM1-70***	\$ 31,635.00	ACE	3.62
A40SMP-84***	\$ 1,380.00	ACE	3.57	A460N6SG-70**	\$ 39,506.00	WDA	3.76	A460NSRM2-70***	\$ 33,435.00	ACE	3.63
A40SMX-84***	\$ 2,720.00	ACE	3.57	A460N6SH-70**	\$ 39,885.00	PWA	3.80	A460NSRM3-70***	\$ 33,435.00	ACE	3.62
A40SN1-84*	\$ 1,155.00	ACE	3.50	A460N6SR-70*	\$ 14,550.00	AEA	3.18	A460NSRM4-70***	\$ 35,850.00	ACE	3.63
A40SN2-84*	\$ 1,335.00	ACE	3.51	A460N6ST-70*1*	\$ 17,995.00	AEA	3.20	A460NSRMX-70***	\$ 41,280.00	ACE	3.63
A40SN3-84*	\$ 1,335.00	ACE	3.50	A460N6ST-70*2*	\$ 13,560.00	AEA	3.22	A460NSRX-70*	\$ 24,250.00	AEAE	3.19

A460NST1-70*1* – A50N2ST-84*1*

Catalog number	List price	Discount schedule	Page number	Catalog number	List price	Discount schedule	Page number	Catalog number	List price	Discount schedule	Page number
A460NST1-70*1*	\$ 28,910.00	AEAE	3.20	A460SR1-70*	\$ 22,482.00	AEAE	3.18	A4G100B2A	-	F3	19.30
A460NST1-70*2*	\$ 22,554.00	AEAE	3.22	A460SR2-70*	\$ 23,230.00	AEAE	3.19	A4G1100B11A	-	F3	19.30
A460NST2-70*1*	\$ 29,652.00	AEAE	3.21	A460SR3-70*	\$ 23,230.00	AEAE	3.19	A4G1200B12A	-	F3	19.30
A460NST2-70*2*	\$ 23,300.00	AEAE	3.23	A460SR4-70*	\$ 23,625.00	AEAE	3.19	A4G125B3B	-	F3	19.30
A460NST3-70*1*	\$ 29,652.00	AEAE	3.21	A460SRF1-70*6F	\$ 29,175.00	ACE	3.54	A4G150B3A	-	F3	19.30
A460NST3-70*2*	\$ 23,300.00	AEAE	3.23	A460SRF1-70*6G	\$ 31,035.00	ACE	3.54	A4G175B4B	-	F3	19.30
A460NST4-70*1*	\$ 30,000.00	AEAE	3.21	A460SRF2-70*6F	\$ 32,025.00	ACE	3.55	A4G200B4A	-	F3	19.30
A460NST4-70*2*	\$ 23,700.00	AEAE	3.23	A460SRF2-70*6G	\$ 33,885.00	ACE	3.55	A4G225B5B	-	F3	19.30
A460NSTX-70*1*	\$ 30,675.00	AEAE	3.21	A460SRF3-70*6G	\$ 32,025.00	ACE	3.54	A4G250B5A	-	F3	19.30
A460NSTX-70*2*	\$ 24,320.00	AEAE	3.23	A460SRF4-70*6F	\$ 33,540.00	ACE	3.55	A4G300B6A	-	F3	19.30
A460NSX-70*	\$ 11,700.00	AEAE	3.15	A460SRF4-70*6G	\$ 35,400.00	ACE	3.55	A4G350B7A	-	F3	19.30
A460NSY1-70**	\$ 53,726.00	WDAE	3.78	A460SRFX-70*6F	\$ 39,420.00	ACE	3.55	A4G400B8A	-	F3	19.30
A460NSY2-70**	\$ 57,101.00	WDAE	3.79	A460SRFX-70*6G	\$ 41,280.00	ACE	3.55	A4G450B9A	-	F3	19.30
A460NSY3-70**	\$ 57,101.00	WDAE	3.79	A460SRM1-70***	\$ 31,635.00	ACE	3.60	A4G500B10A	-	F3	19.30
A460NSY4-70**	\$ 60,476.00	WDAE	3.79	A460SRM2-70***	\$ 33,435.00	ACE	3.61	A4G550B11A	-	F3	19.30
A460NSYX-70**	\$ 66,900.00	WDAE	3.79	A460SRM3-70***	\$ 33,435.00	ACE	3.60	A4G600B12A	-	F3	19.30
A460S-70*	\$ 5,700.00	AEA	3.14	A460SRM4-70***	\$ 35,850.00	ACE	3.61	A4G650B7B	-	F3	19.30
A460S1-70*	\$ 9,375.00	AAE	3.14	A460SRMX-70***	\$ 41,280.00	ACE	3.61	A4G700B7A	-	F3	19.30
A460S2-70*	\$ 10,380.00	AEAE	3.15	A460SRX-70*	\$ 24,250.00	AEAE	3.19	A4G800B8A	-	F3	19.30
A460S3-70*	\$ 9,435.00	AAE	3.14	A460ST-70*1*	\$ 17,995.00	AEA	3.20	A4G900B9A	-	F3	19.30
A460S4-70*	\$ 10,800.00	AEAE	3.15	A460ST-70*2*	\$ 13,560.00	AEA	3.22	A4R1000B10A	-	F3	19.30
A460SA-70*	\$ 35,978.00	RVA	3.74	A460ST1-70*1*	\$ 28,910.00	AEAE	3.20	A4R100B2A	-	F3	19.30
A460SA1-70*	\$ 39,182.00	RVAE	3.74	A460ST1-70*2*	\$ 22,554.00	AEAE	3.22	A4R1100B11A	-	F3	19.30
A460SA2-70*	\$ 42,557.00	RVAE	3.75	A460ST2-70*1*	\$ 29,652.00	AEAE	3.21	A4R1200B12A	-	F3	19.30
A460SA3-70*	\$ 42,557.00	RVAE	3.75	A460ST2-70*2*	\$ 23,300.00	AEAE	3.23	A4R125B3B	-	F3	19.30
A460SA4-70*	\$ 45,932.00	RVAE	3.75	A460ST3-70*1*	\$ 29,652.00	AEAE	3.21	A4R145B4B	-	F3	19.30
A460SAX-70*	\$ 50,700.00	RVAE	3.75	A460ST3-70*2*	\$ 23,300.00	AEAE	3.23	A4R150B3A	-	F3	19.30
A460SF1-70*6F	\$ 16,890.00	ACE	3.52	A460ST4-70*1*	\$ 30,000.00	AEAE	3.21	A4R200B4A	-	F3	19.30
A460SF1-70*6G	\$ 18,750.00	ACE	3.52	A460ST4-70*2*	\$ 23,700.00	AEAE	3.23	A4R225B5B	-	F3	19.30
A460SF2-70*6F	\$ 19,560.00	ACE	3.53	A460STX-70*1*	\$ 30,675.00	AEAE	3.21	A4R250B5A	-	F3	19.30
A460SF2-70*6G	\$ 21,600.00	ACE	3.53	A460STX-70*2*	\$ 24,320.00	AEAE	3.23	A4R300B6A	-	F3	19.30
A460SF3-70*6F	\$ 19,560.00	ACE	3.52	A460SX-70*	\$ 11,700.00	AEAE	3.15	A4R350B7A	-	F3	19.30
A460SF3-70*6G	\$ 21,600.00	ACE	3.52	A460SY-70**	\$ 50,522.00	WDA	3.78	A4R400B8A	-	F3	19.30
A460SF4-70*6F	\$ 21,360.00	ACE	3.53	A460SY1-70**	\$ 53,726.00	WDAE	3.78	A4R450B9A	-	F3	19.30
A460SF4-70*6G	\$ 23,400.00	ACE	3.53	A460SY2-70**	\$ 57,101.00	WDAE	3.79	A4R500B10A	-	F3	19.30
A460SFX-70*6F	\$ 26,955.00	ACE	3.53	A460SY3-70**	\$ 57,101.00	WDAE	3.79	A4R550B11A	-	F3	19.30
A460SFX-70*6G	\$ 28,995.00	ACE	3.53	A460SY4-70**	\$ 60,476.00	WDAE	3.79	A4R600B12A	-	F3	19.30
A460SG-70**	\$ 38,506.00	WDA	3.76	A460SYX-70**	\$ 66,900.00	WDAE	3.79	A4R650B7B	-	F3	19.30
A460SG1-70**	\$ 42,710.00	WDAE	3.76	A4D1000B10A	-	F3	19.30	A4R700B7A	-	F3	19.30
A460SG2-70**	\$ 46,085.00	WDAE	3.77	A4D100B2A	-	F3	19.30	A4R800B8A	-	F3	19.30
A460SG3-70**	\$ 46,085.00	WDAE	3.77	A4D1100B11A	-	F3	19.30	A4R900B9A	-	F3	19.30
A460SG4-70**	\$ 49,460.00	WDAE	3.77	A4D1200B12A	-	F3	19.30	A50-30-11-84	\$ 330.00	AA	1.3
A460SGX-70**	\$ 51,900.00	WDAE	3.77	A4D125B3B	-	F3	19.30	A50-40-00-84	\$ 413.00	AA	1.13
A460SH-70**	\$ 39,885.00	PWA	3.80	A4D150B3A	-	F3	19.30	A503000RT-84	\$ 311.00	AA	1.10
A460SH1-70**	\$ 42,938.00	PWAE	3.80	A4D175B4B	-	F3	19.30	A50M-30-11-84	\$ 713.00	AA	1.3
A460SH2-70**	\$ 47,438.00	PWAE	3.81	A4D200B4A	-	F3	19.30	A50N2-30-11-84	\$ 330.00	AA	1.11
A460SH3-70**	\$ 47,438.00	PWAE	3.81	A4D225B5B	-	F3	19.30	A50N2M-11-84	\$ 713.00	AA	1.11
A460SH4-70**	\$ 48,401.00	PWAE	3.81	A4D250B5A	-	F3	19.30	A50N2R-11-84	\$ 810.00	AA	1.11
A460SHX-70**	\$ 49,913.00	PWAE	3.81	A4D300B6A	-	F3	19.30	A50N2S-84*	\$ 458.00	AA	3.14
A460SM1-70***	\$ 19,350.00	ACE	3.56	A4D350B7A	-	F3	19.30	A50N2SA-84	\$ 4,887.00	RVA	3.74
A460SM2-70***	\$ 21,150.00	ACE	3.57	A4D400B8A	-	F3	19.30	A50N2SG-84**	\$ 3,515.00	WDA	3.76
A460SM3-70***	\$ 21,150.00	ACE	3.56	A4D450B9A	-	F3	19.30	A50N2SH-84**	\$ 2,664.00	PWA	3.80
A460SM4-70***	\$ 22,500.00	ACE	3.57	A4D500B10A	-	F3	19.30	A50N2SP-84*	\$ 698.00	AAE	3.17
A460SMX-70***	\$ 28,995.00	ACE	3.57	A4D550B11A	-	F3	19.30	A50N2SR-84*	\$ 1,152.00	AA	3.18
A460SN1-70*	\$ 17,100.00	ACE	3.50	A4D600B12A	-	F3	19.30	A50N2SS-84*	\$ 458.00	AA	3.16
A460SN2-70*	\$ 18,900.00	ACE	3.51	A4D650B7B	-	F3	19.30	A50N2SS1-84*	\$ 600.00	AAE	3.16
A460SN3-70*	\$ 18,900.00	ACE	3.50	A4D700B7A	-	F3	19.30	A50N2SS2-84*	\$ 719.00	AAE	3.17
A460SN4-70*	\$ 20,700.00	ACE	3.51	A4D800B8A	-	F3	19.30	A50N2SS3-84*	\$ 719.00	AAE	3.17
A460SNX-70*	\$ 27,900.00	ACE	3.51	A4D900B9A	-	F3	19.30	A50N2SS4-84*	\$ 1,103.00	AAE	3.17
A460SR-70*	\$ 14,550.00	AEA	3.18	A4G1000B10A	-	F3	19.30	A50N2ST-84*1*	\$ 1,697.00	AA	3.20

A50N2ST-84*2* – A580SA4-70*

Alphanumeric

0

Catalog number	List price	Discount schedule	Page number	Catalog number	List price	Discount schedule	Page number	Catalog number	List price	Discount schedule	Page number
A50N2ST-84*2*	\$ 1,224.00	AA	3.22	A50NST1-84*1*	\$ 1,940.00	AAE	3.20	A50SNP-84*	\$ 1,770.00	ACE	3.51
A50N2SX-84*	\$ 1,328.00	AAE	3.17	A50NST1-84*2*	\$ 1,467.00	AAE	3.22	A50SNX-84*	\$ 3,100.00	ACE	3.51
A50N2SY-84**	\$ 5,396.00	WDA	3.78	A50NST2-84*1*	\$ 2,307.00	AAE	3.21	A50SP-84*	\$ 698.00	AAE	3.15
A50NS1-84*	\$ 600.00	AAE	3.14	A50NST2-84*2*	\$ 1,835.00	AAE	3.23	A50SR-84*	\$ 1,152.00	AA	3.18
A50NS2-84*	\$ 719.00	AAE	3.15	A50NST3-84*1*	\$ 2,307.00	AAE	3.21	A50SR1-84*	\$ 1,395.00	AAE	3.18
A50NS3-84*	\$ 719.00	AAE	3.14	A50NST3-84*2*	\$ 1,835.00	AAE	3.23	A50SR2-84*	\$ 1,763.00	AAE	3.19
A50NS4-84*	\$ 1,103.00	AAE	3.15	A50NST4-84*1*	\$ 2,528.00	AAE	3.21	A50SR3-84*	\$ 1,763.00	AAE	3.19
A50NS7-84*	\$ 2,079.00	AXE	3.15	A50NST4-84*2*	\$ 1,988.00	AAE	3.23	A50SR4-84*	\$ 1,875.00	AAE	3.19
A50NSA1-84*	\$ 6,003.00	RVAE	3.74	A50NSTP-84*1*	\$ 2,075.00	AAE	3.21	A50SRF1-84*6C	\$ 2,438.00	ACE	3.54
A50NSA2-84*	\$ 6,723.00	RVAE	3.75	A50NSTP-84*2*	\$ 1,602.00	AAE	3.23	A50SRF2-84*6C	\$ 2,625.00	ACE	3.55
A50NSA3-84*	\$ 6,723.00	RVAE	3.75	A50NSTX-84*1*	\$ 2,757.00	AAE	3.21	A50SRF3-84*6C	\$ 2,625.00	ACE	3.54
A50NSA4-84*	\$ 7,893.00	RVAE	3.75	A50NSTX-84*2*	\$ 2,285.00	AAE	3.23	A50SRF4-84*6C	\$ 2,850.00	ACE	3.55
A50NSAX-84*	\$ 9,600.00	RVAE	3.75	A50NSX-84*	\$ 1,328.00	AAE	3.15	A50SRFP-84*6C	\$ 2,573.00	ACE	3.55
A50NSF1-84*6B	\$ 1,725.00	ACE	3.52	A50NSY1-84**	\$ 5,540.00	WDAE	3.78	A50SRFX-84*6C	\$ 3,855.00	ACE	3.55
A50NSF2-84*6B	\$ 1,913.00	ACE	3.53	A50NSY2-84**	\$ 6,665.00	WDAE	3.79	A50SRM1-84***	\$ 2,468.00	ACE	3.60
A50NSF3-84*6B	\$ 1,913.00	ACE	3.52	A50NSY3-84**	\$ 6,665.00	WDAE	3.79	A50SRM2-84***	\$ 2,648.00	ACE	3.61
A50NSF4-84*6B	\$ 2,400.00	ACE	3.53	A50NSY4-84**	\$ 6,755.00	WDAE	3.79	A50SRM3-84***	\$ 2,648.00	ACE	3.60
A50NSFX-84*6B	\$ 1,830.00	ACE	3.53	A50NSYX-84**	\$ 7,650.00	WDAE	3.79	A50SRM4-84***	\$ 2,963.00	ACE	3.61
A50NSFX-84*6B	\$ 3,240.00	ACE	3.53	A50R-30-11-84	\$ 810.00	AA	1.3	A50SRMP-84***	\$ 2,618.00	ACE	3.61
A50NSG1-84*	\$ 3,659.00	WDAE	3.76	A50S-84*	\$ 458.00	AA	3.14	A50SRMX-84***	\$ 3,988.00	ACE	3.61
A50NSG2-84**	\$ 4,784.00	WDAE	3.77	A50S1-84*	\$ 600.00	AAE	3.14	A50SRP-84*	\$ 1,530.00	AAE	3.19
A50NSG3-84**	\$ 4,784.00	WDAE	3.77	A50S2-84*	\$ 719.00	AAE	3.15	A50SRX-84*	\$ 2,213.00	AAE	3.19
A50NSG4-84**	\$ 4,874.00	WDAE	3.77	A50S3-84*	\$ 719.00	AAE	3.14	A50SS-84*	\$ 458.00	AA	3.16
A50NSGX-84**	\$ 5,738.00	WDAE	3.77	A50S4-84*	\$ 1,103.00	AAE	3.15	A50SS1-84*	\$ 600.00	AAE	3.16
A50NSH1-84**	\$ 2,808.00	PWAE	3.80	A50S7-84*	\$ 2,600.00	AXE	3.15	A50SS2-84*	\$ 719.00	AAE	3.17
A50NSH3-84**	\$ 3,933.00	PWAE	3.81	A50SA-84*	\$ 4,887.00	RVA	3.74	A50SS3-84*	\$ 719.00	AAE	3.17
A50NSH4-84**	\$ 4,023.00	PWAE	3.81	A50SA1-84*	\$ 6,003.00	RVAE	3.74	A50SS4-84*	\$ 1,103.00	AAE	3.17
A50NSHX-84**	\$ 4,500.00	PWAE	3.81	A50SA2-84*	\$ 6,723.00	RVAE	3.75	A50SSP-84*	\$ 698.00	AAE	3.17
A50NSM1-84***	\$ 1,755.00	ACE	3.58	A50SA3-84*	\$ 6,723.00	RVAE	3.75	A50SSX-84*	\$ 1,328.00	AAE	3.17
A50NSM2-84***	\$ 1,935.00	ACE	3.59	A50SA4-84*	\$ 7,893.00	RVAE	3.75	A50ST-84*1*	\$ 1,697.00	AA	3.20
A50NSM3-84****	\$ 1,935.00	ACE	3.58	A50SAX-84*	\$ 9,600.00	RVAE	3.75	A50ST-84*2*	\$ 1,224.00	AA	3.22
A50NSM4-84****	\$ 2,115.00	ACE	3.59	A50SF1-84*6C	\$ 1,725.00	ACE	3.52	A50ST1-84*1*	\$ 1,940.00	AAE	3.20
A50NSM7-84****	\$ 4,150.00	AXE	3.59	A50SF2-84*6C	\$ 1,913.00	ACE	3.53	A50ST1-84*2*	\$ 1,467.00	AAE	3.22
A50NSMP-84****	\$ 1,875.00	ACE	3.59	A50SF3-84*6C	\$ 1,913.00	ACE	3.52	A50ST2-84*1*	\$ 2,307.00	AAE	3.21
A50NSMX-84****	\$ 3,275.00	ACE	3.59	A50SF4-84*6C	\$ 2,400.00	ACE	3.53	A50ST2-84*2*	\$ 1,835.00	AAE	3.23
A50NSN1-84*	\$ 1,650.00	ACE	3.50	A50SFP-84*6C	\$ 1,830.00	ACE	3.53	A50ST3-84*1*	\$ 2,307.00	AAE	3.21
A50NSN2-84*	\$ 1,830.00	ACE	3.51	A50SFX-84*6C	\$ 3,340.00	ACE	3.53	A50ST3-84*2*	\$ 1,835.00	AAE	3.23
A50NSN3-84*	\$ 1,830.00	ACE	3.50	A50SG-84**	\$ 3,515.00	WDA	3.76	A50ST4-84*1*	\$ 2,528.00	AAE	3.21
A50NSN4-84*	\$ 2,190.00	ACE	3.51	A50SG1-84**	\$ 3,659.00	WDAE	3.76	A50ST4-84*2*	\$ 1,988.00	AAE	3.23
A50NSNP-84*	\$ 1,770.00	ACE	3.51	A50SG2-84**	\$ 4,784.00	WDAE	3.77	A50STP-84*1*	\$ 2,075.00	AAE	3.21
A50NSNX-84*	\$ 3,100.00	ACE	3.51	A50SG3-84**	\$ 4,784.00	WDAE	3.77	A50STP-84*2*	\$ 1,602.00	AAE	3.23
A50NSP-84*	\$ 698.00	AAE	3.15	A50SG4-84**	\$ 4,874.00	WDAE	3.77	A50STX-84*1*	\$ 2,757.00	AAE	3.21
A50NSR1-84*	\$ 1,395.00	AAE	3.18	A50SGX-84**	\$ 5,738.00	WDAE	3.77	A50STX-84*2*	\$ 2,285.00	AAE	3.23
A50NSR2-84*	\$ 1,763.00	AAE	3.19	A50SH-84**	\$ 2,664.00	PWA	3.80	A50SX-84*	\$ 1,328.00	AAE	3.15
A50NSR3-84*	\$ 1,763.00	AAE	3.19	A50SH1-84**	\$ 2,808.00	PWAE	3.80	A50SY-84**	\$ 5,396.00	WDA	3.78
A50NSR4-84*	\$ 1,875.00	AAE	3.19	A50SH2-84**	\$ 3,933.00	PWAE	3.81	A50SY1-84**	\$ 5,540.00	WDAE	3.78
A50NSRF1-84*6B	\$ 2,438.00	ACE	3.54	A50SH3-84**	\$ 3,933.00	PWAE	3.81	A50SY2-84**	\$ 6,665.00	WDAE	3.79
A50NSRF2-84*6B	\$ 2,625.00	ACE	3.55	A50SH4-84**	\$ 4,023.00	PWAE	3.81	A50SY3-84**	\$ 6,665.00	WDAE	3.79
A50NSRF3-84*6B	\$ 2,625.00	ACE	3.54	A50SHX-84**	\$ 4,500.00	PWAE	3.81	A50SY4-84**	\$ 6,755.00	WDAE	3.79
A50NSRF4-84*6B	\$ 2,850.00	ACE	3.55	A50SM1-84***	\$ 1,755.00	ACE	3.56	A50SYX-84**	\$ 7,650.00	WDAE	3.79
A50NSRFP-84*6B	\$ 2,573.00	ACE	3.55	A50SM2-84***	\$ 1,935.00	ACE	3.57	A580S-70*	\$ 8,346.00	AEA	3.14
A50NSRFX-84*6B	\$ 3,855.00	ACE	3.55	A50SM3-84***	\$ 1,935.00	ACE	3.56	A580S1-70*	\$ 12,400.00	AAE	3.14
A50NSRM1-84***	\$ 2,468.00	ACE	3.62	A50SM4-84***	\$ 2,115.00	ACE	3.57	A580S2-70*	\$ 13,465.00	AEAE	3.15
A50NSRM2-84***	\$ 2,648.00	ACE	3.63	A50SM7-84***	\$ 4,150.00	AXE	3.57	A580S3-70*	\$ 13,465.00	AAE	3.14
A50NSRM3-84***	\$ 2,648.00	ACE	3.62	A50SMP-84***	\$ 1,875.00	ACE	3.57	A580S4-70*	\$ 14,250.00	AEAE	3.15
A50NSRM4-84***	\$ 2,963.00	ACE	3.63	A50SMX-84***	\$ 3,275.00	ACE	3.57	A580SA-70*	\$ 52,562.00	RVA	3.74
A50NSRMP-84***	\$ 2,618.00	ACE	3.63	A50SN1-84*	\$ 1,650.00	ACE	3.50	A580SA1-70*	\$ 55,898.00	RVAE	3.74
A50NSRMX-84***	\$ 3,988.00	ACE	3.63	A50SN2-84*	\$ 1,830.00	ACE	3.51	A580SA2-70*	\$ 59,997.00	RVAE	3.75
A50NSRP-84*	\$ 1,530.00	AAE	3.19	A50SN3-84*	\$ 1,830.00	ACE	3.50	A580SA3-70*	\$ 59,997.00	RVAE	3.75
A50NSRX-84*	\$ 2,213.00	AAE	3.19	A50SN4-84*	\$ 2,190.00	ACE	3.51	A580SA4-70*	\$ 62,324.00	RVAE	3.75

A580SAX-70* – A6G1000B10A

Catalog number	List price	Discount schedule	Page number	Catalog number	List price	Discount schedule	Page number	Catalog number	List price	Discount schedule	Page number
A580SAX-70*	\$ 68,700.00	RVAE	3.75	A580SY3-70**	\$ 72,749.00	WDAE	3.79	A63SRFP-84*6C	\$ 2,985.00	ACE	3.55
A580SF1-70*6H	\$ 22,050.00	ACE	3.52	A580SY4-70**	\$ 75,633.00	WDAE	3.79	A63SRFX-84*6C	\$ 4,370.00	ACE	3.55
A580SF2-70*6H	\$ 25,050.00	ACE	3.53	A580SYX-70**	\$ 83,625.00	WDAE	3.79	A63SRM1-84***	\$ 2,070.00	ACE	3.60
A580SF3-70*6H	\$ 25,050.00	ACE	3.52	A63-30-11-84	\$ 372.00	AA	1.3	A63SRM2-84***	\$ 3,030.00	ACE	3.61
A580SF4-70*6H	\$ 27,000.00	ACE	3.53	A633000RT-84	\$ 354.00	AA	1.10	A63SRM3-84***	\$ 3,030.00	ACE	3.60
A580SFX-70*6H	\$ 37,350.00	ACE	3.53	A63M-30-11-84	\$ 870.00	AA	1.3	A63SRM4-84***	\$ 3,338.00	ACE	3.61
A580SG-70**	\$ 49,409.00	WDA	3.76	A63R-30-11-84	\$ 1,013.00	AA	1.3	A63SRMP-84***	\$ 3,090.00	ACE	3.61
A580SG1-70**	\$ 51,018.00	WDAE	3.76	A63S-84*	\$ 522.00	AA	3.14	A63SRMX-84***	\$ 4,505.00	ACE	3.61
A580SG2-70**	\$ 54,576.00	WDAE	3.77	A63S1-84*	\$ 713.00	AAE	3.14	A63SRP-84*	\$ 1,695.00	AAE	3.19
A580SG3-70**	\$ 54,576.00	WDAE	3.77	A63S2-84*	\$ 795.00	AAE	3.15	A63SRX-84*	\$ 3,143.00	AAE	3.19
A580SG4-70**	\$ 57,783.00	WDAE	3.77	A63S3-84*	\$ 795.00	AAE	3.14	A63SS-84*	\$ 522.00	AA	3.16
A580SGX-70**	\$ 61,425.00	WDAE	3.77	A63S4-84*	\$ 1,170.00	AAE	3.15	A63SS1-84*	\$ 713.00	AAE	3.16
A580SH-70**	\$ 42,158.00	PWA	3.80	A63S7-84*	\$ 3,350.00	AXE	3.15	A63SS2-84*	\$ 795.00	AAE	3.17
A580SH1-70**	\$ 51,471.00	PWAE	3.80	A63SA-84*	\$ 5,130.00	RVA	3.74	A63SS3-84*	\$ 795.00	AAE	3.17
A580SH2-70**	\$ 55,971.00	PWAE	3.81	A63SA1-84*	\$ 6,246.00	RVAE	3.74	A63SS4-84*	\$ 1,170.00	AAE	3.17
A580SH3-70**	\$ 55,971.00	PWAE	3.81	A63SA2-84*	\$ 7,694.00	RVAE	3.75	A63SSP-84*	\$ 773.00	AAE	3.17
A580SH4-70**	\$ 56,934.00	PWAE	3.81	A63SA3-84*	\$ 7,694.00	RVAE	3.75	A63SSX-84*	\$ 1,410.00	AAE	3.17
A580SHX-70**	\$ 59,400.00	PWAE	3.81	A63SA4-84*	\$ 9,014.00	RVAE	3.75	A63ST-84*1*	\$ 2,150.00	AA	3.20
A580SM1-70***	\$ 22,650.00	ACE	3.56	A63SAX-84*	\$ 10,725.00	RVAE	3.75	A63ST-84*2*	\$ 1,587.00	AA	3.22
A580SM2-70***	\$ 24,450.00	ACE	3.57	A63SF1-84*6C	\$ 1,980.00	ACE	3.52	A63ST1-84*1*	\$ 2,195.00	AAE	3.20
A580SM3-70***	\$ 24,450.00	ACE	3.56	A63SF2-84*6C	\$ 2,138.00	ACE	3.53	A63ST1-84*2*	\$ 1,632.00	AAE	3.22
A580SM4-70***	\$ 26,850.00	ACE	3.57	A63SF3-84*6C	\$ 2,138.00	ACE	3.52	A63ST2-84*1*	\$ 2,945.00	AAE	3.21
A580SMX-70***	\$ 36,000.00	ACE	3.57	A63SF4-84*6C	\$ 2,640.00	ACE	3.53	A63ST2-84*2*	\$ 2,382.00	AAE	3.23
A580SN1-70*	\$ 20,490.00	ACE	3.50	A63SFP-84*6C	\$ 2,055.00	ACE	3.53	A63ST3-84*1*	\$ 2,945.00	AAE	3.21
A580SN2-70*	\$ 22,290.00	ACE	3.51	A63SFX-84*6C	\$ 3,600.00	ACE	3.53	A63ST3-84*2*	\$ 2,382.00	AAE	3.23
A580SN3-70*	\$ 22,290.00	ACE	3.50	A63SG-84**	\$ 3,615.00	WDA	3.76	A63ST4-84*1*	\$ 3,285.00	AAE	3.21
A580SN4-70*	\$ 24,750.00	ACE	3.51	A63SG1-84**	\$ 4,704.00	WDAE	3.76	A63ST4-84*2*	\$ 2,513.00	AAE	3.23
A580SNX-70*	\$ 32,550.00	ACE	3.51	A63SG2-84**	\$ 5,847.00	WDAE	3.77	A63STP-84*1*	\$ 2,330.00	AAE	3.21
A580SR-70*	\$ 19,755.00	AEA	3.18	A63SG3-84**	\$ 5,847.00	WDAE	3.77	A63STP-84*2*	\$ 1,767.00	AAE	3.23
A580SR1-70*	\$ 25,800.00	AEAE	3.18	A63SG4-84**	\$ 5,850.00	WDAE	3.77	A63STX-84*1*	\$ 3,777.00	AAE	3.21
A580SR2-70*	\$ 26,250.00	AEAE	3.19	A63SGX-84**	\$ 6,750.00	WDAE	3.77	A63STX-84*2*	\$ 3,215.00	AAE	3.23
A580SR3-70*	\$ 26,250.00	AEAE	3.19	A63SH-84**	\$ 3,305.00	PWA	3.80	A63SX-84*	\$ 1,410.00	AAE	3.15
A580SR4-70*	\$ 27,000.00	AEAE	3.19	A63SH1-84**	\$ 3,458.00	PWAE	3.80	A63SY-84**	\$ 7,034.00	WDA	3.78
A580SRF1-70*6H	\$ 39,435.00	ACE	3.54	A63SH2-84**	\$ 4,583.00	PWAE	3.81	A63SY1-84**	\$ 7,592.00	WDAE	3.78
A580SRF2-70*6H	\$ 42,435.00	ACE	3.55	A63SH3-84**	\$ 4,583.00	PWAE	3.81	A63SY2-84**	\$ 8,942.00	WDAE	3.79
A580SRF3-70*6H	\$ 42,435.00	ACE	3.54	A63SH4-84**	\$ 4,673.00	PWAE	3.81	A63SY3-84**	\$ 8,942.00	WDAE	3.79
A580SRF4-70*6H	\$ 45,150.00	ACE	3.55	A63SHX-84**	\$ 5,363.00	PWAE	3.81	A63SY4-84**	\$ 9,347.00	WDAE	3.79
A580SRFX-70*6H	\$ 54,735.00	ACE	3.55	A63SM1-84***	\$ 2,070.00	ACE	3.56	A63SYX-84**	\$ 10,163.00	WDAE	3.79
A580SRM1-70***	\$ 40,035.00	ACE	3.60	A63SM2-84***	\$ 2,160.00	ACE	3.57	A6D1000B10A	-	F3	19.30
A580SRM2-70***	\$ 41,835.00	ACE	3.61	A63SM3-84***	\$ 2,160.00	ACE	3.56	A6D100B2A	-	F3	19.30
A580SRM3-70***	\$ 41,835.00	ACE	3.60	A63SM4-84***	\$ 2,438.00	ACE	3.57	A6D1100B11A	-	F3	19.30
A580SRM4-70***	\$ 45,000.00	ACE	3.61	A63SM7-84***	\$ 5,540.00	AXE	3.57	A6D1200B12A	-	F3	19.30
A580SRMX-70***	\$ 53,385.00	ACE	3.61	A63SMP-84***	\$ 2,100.00	ACE	3.57	A6D125B3B	-	F3	19.30
A580SRX-70*	\$ 28,500.00	AEAE	3.19	A63SMX-84***	\$ 3,635.00	ACE	3.57	A6D150B3A	-	F3	19.30
A580ST-70*1*	\$ 23,735.00	AEA	3.20	A63SN1-84*	\$ 1,875.00	ACE	3.50	A6D175B4B	-	F3	19.30
A580ST-70*2*	\$ 18,660.00	AEA	3.22	A63SN2-84*	\$ 2,055.00	ACE	3.51	A6D200B4A	-	F3	19.30
A580ST1-70*1*	\$ 35,400.00	AEAE	3.20	A63SN3-84*	\$ 2,055.00	ACE	3.50	A6D225B5B	-	F3	19.30
A580ST1-70*2*	\$ 25,872.00	AEAE	3.22	A63SN4-84*	\$ 2,535.00	ACE	3.51	A6D250B5A	-	F3	19.30
A580ST2-70*1	\$ 35,850.00	AEAE	3.21	A63SNP-84*	\$ 1,995.00	ACE	3.51	A6D300B6A	-	F3	19.30
A580ST2-70*2*	\$ 26,322.00	AEAE	3.23	A63SNX-84*	\$ 3,550.00	ACE	3.51	A6D350B7A	-	F3	19.30
A580ST3-70*1*	\$ 35,850.00	AEAE	3.21	A63SP-84*	\$ 773.00	AAE	3.15	A6D400B8A	-	F3	19.30
A580ST3-70*2*	\$ 26,322.00	AEAE	3.23	A63SR-84*	\$ 1,515.00	AA	3.18	A6D450B9A	-	F3	19.30
A580ST4-70*1*	\$ 36,225.00	AEAE	3.21	A63SR1-84*	\$ 1,780.00	AAE	3.18	A6D500B10A	-	F3	19.30
A580ST4-70*2*	\$ 27,000.00	AEAE	3.23	A63SR2-84*	\$ 2,310.00	AAE	3.19	A6D550B11A	-	F3	19.30
A580STX-70*1*	\$ 38,097.00	AEAE	3.21	A63SR3-84*	\$ 2,310.00	AAE	3.19	A6D600B12A	-	F3	19.30
A580STX-70*2*	\$ 28,570.00	AEAE	3.23	A63SR4-84*	\$ 2,588.00	AAE	3.19	A6D650B7B	-	F3	19.30
A580SX-70*	\$ 14,590.00	AEAE	3.15	A63SRF1-84*6C	\$ 2,850.00	ACE	3.54	A6D700B7A	-	F3	19.30
A580SY-70**	\$ 65,910.00	WDA	3.78	A63SRF2-84*6C	\$ 3,008.00	ACE	3.55	A6D800B8A	-	F3	19.30
A580SY1-70**	\$ 68,132.00	WDAE	3.78	A63SRF3-84*6C	\$ 3,008.00	ACE	3.54	A6D900B9A	-	F3	19.30
A580SY2-70**	\$ 72,749.00	WDAE	3.79	A63SRF4-84*6C	\$ 3,225.00	ACE	3.55	A6G1000B10A	-	F3	19.30

A6G100B2A – A750ST4-70*1*

Alphanumeric

0

Catalog number	List price	Discount schedule	Page number	Catalog number	List price	Discount schedule	Page number	Catalog number	List price	Discount schedule	Page number
A6G100B2A	-	F3	19.30	A750NSAX-70*	\$ 75,300.00	RVAE	3.75	A750S3-70*	\$ 14,325.00	AAE	3.14
A6G1100B11A	-	F3	19.30	A750NSF1-70*6H	\$ 23,550.00	ACE	3.52	A750S4-70*	\$ 14,850.00	AEAE	3.15
A6G1200B12A	-	F3	19.30	A750NSF2-70*6H	\$ 28,050.00	ACE	3.53	A750SA-70*	\$ 59,250.00	RVA	3.74
A6G125B3B	-	F3	19.30	A750NSF3-70*6H	\$ 28,050.00	ACE	3.52	A750SA1-70*	\$ 62,618.00	RVAE	3.74
A6G150B3A	-	F3	19.30	A750NSF4-70*6H	\$ 30,000.00	ACE	3.53	A750SA2-70*	\$ 65,993.00	RVAE	3.75
A6G175B4B	-	F3	19.30	A750NSFX-70*6H	\$ 39,000.00	ACE	3.53	A750SA3-70*	\$ 65,993.00	RVAE	3.75
A6G200B4A	-	F3	19.30	A750NSG1-70**	\$ 57,605.00	WDAE	3.76	A750SA4-70*	\$ 69,368.00	RVAE	3.75
A6G225B5B	-	F3	19.30	A750NSG2-70**	\$ 60,980.00	WDAE	3.77	A750SAX-70*	\$ 75,300.00	RVAE	3.75
A6G250B5A	-	F3	19.30	A750NSG3-70**	\$ 60,980.00	WDAE	3.77	A750SF1-70*6H	\$ 23,550.00	ACE	3.52
A6G300B6A	-	F3	19.30	A750NSG4-70**	\$ 64,355.00	WDAE	3.77	A750SF2-70*6H	\$ 28,050.00	ACE	3.53
A6G350B7A	-	F3	19.30	A750NSGX-70**	\$ 70,125.00	WDAE	3.77	A750SF3-70*6H	\$ 28,050.00	ACE	3.52
A6G400B8A	-	F3	19.30	A750NSH1-70**	\$ 56,664.00	PWAE	3.80	A750SF4-70*6H	\$ 30,000.00	ACE	3.53
A6G450B9A	-	F3	19.30	A750NSH2-70**	\$ 62,064.00	PWAE	3.81	A750SFX-70*6H	\$ 39,000.00	ACE	3.53
A6G500B10A	-	F3	19.30	A750NSH3-70**	\$ 62,064.00	PWAE	3.81	A750SG-70**	\$ 54,401.00	WDA	3.76
A6G550B11A	-	F3	19.30	A750NSH4-70**	\$ 62,541.00	PWAE	3.81	A750SG1-70**	\$ 57,605.00	WDAE	3.76
A6G600B12A	-	F3	19.30	A750NSHX-70**	\$ 66,150.00	PWAE	3.81	A750SG2-70**	\$ 60,980.00	WDAE	3.77
A6G650B7B	-	F3	19.30	A750NSM1-70***	\$ 24,150.00	ACE	3.58	A750SG3-70**	\$ 60,980.00	WDAE	3.77
A6G700B7A	-	F3	19.30	A750NSM2-70***	\$ 27,330.00	ACE	3.59	A750SG4-70**	\$ 64,355.00	WDAE	3.77
A6G800B8A	-	F3	19.30	A750NSM3-70***	\$ 27,330.00	ACE	3.58	A750SGX-70**	\$ 70,125.00	WDAE	3.77
A6G900B9A	-	F3	19.30	A750NSM4-70***	\$ 30,000.00	ACE	3.59	A750SH-70**	\$ 50,994.00	PWA	3.80
A6R1000B10A	-	F3	19.30	A750NSMX-70***	\$ 37,650.00	ACE	3.59	A750SH1-70**	\$ 56,664.00	PWAE	3.80
A6R100B2A	-	F3	19.30	A750NSN1-70*	\$ 21,990.00	ACE	3.50	A750SH2-70**	\$ 62,064.00	PWAE	3.81
A6R1100B11A	-	F3	19.30	A750NSN2-70*	\$ 25,050.00	ACE	3.51	A750SH3-70**	\$ 62,064.00	PWAE	3.81
A6R1200B12A	-	F3	19.30	A750NSN3-70*	\$ 25,050.00	ACE	3.50	A750SH4-70**	\$ 62,541.00	PWAE	3.81
A6R125B3B	-	F3	19.30	A750NSN4-70*	\$ 26,850.00	ACE	3.51	A750SHX-70**	\$ 66,150.00	PWAE	3.81
A6R150B3A	-	F3	19.30	A750NSNX-70*	\$ 34,800.00	ACE	3.51	A750SM1-70***	\$ 24,150.00	ACE	3.56
A6R175B4B	-	F3	19.30	A750NSR1-70*	\$ 29,250.00	AEAE	3.18	A750SM2-70***	\$ 27,330.00	ACE	3.57
A6R200B4A	-	F3	19.30	A750NSR2-70*	\$ 30,225.00	AEAE	3.19	A750SM3-70***	\$ 27,330.00	ACE	3.56
A6R225B5B	-	F3	19.30	A750NSR3-70*	\$ 30,225.00	AEAE	3.19	A750SM4-70***	\$ 30,000.00	ACE	3.57
A6R250B5A	-	F3	19.30	A750NSR4-70*	\$ 31,275.00	AEAE	3.19	A750SMX-70***	\$ 37,650.00	ACE	3.57
A6R300B6A	-	F3	19.30	A750NSRF1-70*6H	\$ 42,285.00	ACE	3.54	A750SN1-70*	\$ 21,990.00	ACE	3.50
A6R350B7A	-	F3	19.30	A750NSRF2-70*6H	\$ 46,785.00	ACE	3.55	A750SN2-70*	\$ 25,050.00	ACE	3.51
A6R400B8A	-	F3	19.30	A750NSRF3-70*6H	\$ 46,785.00	ACE	3.54	A750SN3-70*	\$ 25,050.00	ACE	3.50
A6R450B9A	-	F3	19.30	A750NSRF4-70*6H	\$ 48,450.00	ACE	3.55	A750SN4-70*	\$ 26,850.00	ACE	3.51
A6R500B10A	-	F3	19.30	A750NSRFX-70*6H	\$ 57,735.00	ACE	3.55	A750SNX-70*	\$ 34,800.00	ACE	3.51
A6R550B11A	-	F3	19.30	A750NSRM1-70***	\$ 42,885.00	ACE	3.62	A750SR-70*	\$ 21,105.00	AEA	3.18
A6R600B12A	-	F3	19.30	A750NSRM2-70***	\$ 46,065.00	ACE	3.63	A750SR1-70*	\$ 29,250.00	AEAE	3.18
A6R650B7B	-	F3	19.30	A750NSRM3-70***	\$ 46,065.00	ACE	3.62	A750SR2-70*	\$ 30,225.00	AEAE	3.19
A6R700B7A	-	F3	19.30	A750NSRM4-70***	\$ 48,338.00	ACE	3.63	A750SR3-70*	\$ 30,225.00	AEAE	3.19
A6R800B8A	-	F3	19.30	A750NSRMX-70***	\$ 56,385.00	ACE	3.63	A750SR4-70*	\$ 31,275.00	AEAE	3.19
A6R900B9A	-	F3	19.30	A750NSRX-70*	\$ 32,625.00	AEAE	3.19	A750SRF1-70*6H	\$ 42,285.00	ACE	3.54
A75-22-00-84	\$ 525.00	AA	1.13	A750NST1-70*1*	\$ 39,195.00	AEAE	3.20	A750SRF2-70*6H	\$ 46,785.00	ACE	3.55
A75-30-11-84	\$ 413.00	AA	1.3	A750NST1-70*2*	\$ 29,322.00	AEAE	3.22	A750SRF3-70*6H	\$ 46,785.00	ACE	3.54
A75-40-00-84	\$ 525.00	AA	1.13	A750NST2-70*1*	\$ 40,170.00	AEAE	3.21	A750SRF4-70*6H	\$ 48,450.00	ACE	3.55
A750N7S-70*	\$ 8,646.00	AEA	3.14	A750NST2-70*2*	\$ 30,297.00	AEAE	3.23	A750SRFX-70*6H	\$ 57,735.00	ACE	3.55
A750N7S7-70**	\$ 71,495.00	WDA	3.78	A750NST3-70*1*	\$ 40,170.00	AEAE	3.21	A750SRM1-70***	\$ 42,885.00	ACE	3.60
A750N7SA-70*	\$ 59,250.00	RVA	3.74	A750NST3-70*2*	\$ 30,297.00	AEAE	3.23	A750SRM2-70***	\$ 46,065.00	ACE	3.61
A750N7SG-70**	\$ 54,401.00	WDA	3.76	A750NST4-70*1*	\$ 40,875.00	AEAE	3.21	A750SRM3-70***	\$ 46,065.00	ACE	3.60
A750N7SH-70**	\$ 50,994.00	PWA	3.80	A750NST4-70*2*	\$ 30,900.00	AEAE	3.23	A750SRM4-70***	\$ 48,338.00	ACE	3.61
A750N7SR-70*	\$ 21,105.00	AEA	3.18	A750NSTX-70*1*	\$ 42,570.00	AEAE	3.21	A750SRMX-70***	\$ 56,385.00	ACE	3.61
A750N7ST-70*1*	\$ 26,645.00	AEA	3.20	A750NSTX-70*2*	\$ 32,697.00	AEAE	3.23	A750SRX-70*	\$ 32,625.00	AEAE	3.19
A750N7ST-70*2*	\$ 20,025.00	AEA	3.22	A750NSX-70*	\$ 15,745.00	AEAE	3.15	A750ST-70*1*	\$ 26,645.00	AEA	3.20
A750NS1-70*	\$ 13,350.00	AAE	3.14	A750NSY1-70**	\$ 74,696.00	WDAE	3.78	A750ST-70*2*	\$ 20,025.00	AEA	3.22
A750NS2-70*	\$ 14,325.00	AEAE	3.15	A750NSY2-70**	\$ 78,071.00	WDAE	3.79	A750ST1-70*1*	\$ 39,195.00	AEAE	3.20
A750NS3-70*	\$ 14,325.00	AAE	3.14	A750NSY3-70**	\$ 78,071.00	WDAE	3.79	A750ST1-70*2*	\$ 29,322.00	AEAE	3.22
A750NS4-70*	\$ 14,850.00	AEAE	3.15	A750NSY4-70**	\$ 81,446.00	WDAE	3.79	A750ST2-70*1*	\$ 40,170.00	AEAE	3.21
A750NSA1-70*	\$ 62,618.00	RVAE	3.74	A750NSYX-70**	\$ 88,725.00	WDAE	3.79	A750ST2-70*2*	\$ 30,297.00	AEAE	3.23
A750NSA2-70*	\$ 65,993.00	RVAE	3.75	A750S-70*	\$ 8,646.00	AEA	3.14	A750ST3-70*1*	\$ 40,170.00	AEAE	3.21
A750NSA3-70*	\$ 65,993.00	RVAE	3.75	A750S1-70*	\$ 13,350.00	AAE	3.14	A750ST3-70*2*	\$ 30,297.00	AEAE	3.23
A750NSA4-70*	\$ 69,368.00	RVAE	3.75	A750S2-70*	\$ 14,325.00	AEAE	3.15	A750ST4-70*1*	\$ 40,875.00	AEAE	3.21

A750ST4-70*2* – A75SS4-84*

Catalog number	List price	Discount schedule	Page number	Catalog number	List price	Discount schedule	Page number	Catalog number	List price	Discount schedule	Page number
A750ST4-70*2*	\$ 30,900.00	AEAE	3.23	A75NSMP-84***	\$ 2,520.00	ACE	3.59	A75SA2-84*	\$ 8,181.00	RVAE	3.75
A750STX-70*1*	\$ 42,570.00	AEAE	3.21	A75NSMX-84***	\$ 4,055.00	ACE	3.59	A75SA3-84*	\$ 8,181.00	RVAE	3.75
A750STX-70*2*	\$ 32,697.00	AEAE	3.23	A75NSN1-84*	\$ 2,295.00	ACE	3.50	A75SA4-84*	\$ 9,261.00	RVAE	3.75
A750SX-70*	\$ 15,745.00	AEAE	3.15	A75NSN2-84*	\$ 2,775.00	ACE	3.51	A75SAX-84*	\$ 10,988.00	RVAE	3.75
A750SY-70**	\$ 71,492.00	WDA	3.78	A75NSN3-84*	\$ 2,775.00	ACE	3.50	A75SF1-84*6D	\$ 2,445.00	ACE	3.52
A750SY1-70**	\$ 74,696.00	WDAE	3.78	A75NSN4-84*	\$ 3,015.00	ACE	3.51	A75SF2-84*6D	\$ 2,858.00	ACE	3.53
A750SY2-70**	\$ 78,071.00	WDAE	3.79	A75NSNP-84*	\$ 2,415.00	ACE	3.51	A75SF3-84*6D	\$ 2,858.00	ACE	3.52
A750SY3-70**	\$ 78,071.00	WDAE	3.79	A75NSNX-84*	\$ 4,000.00	ACE	3.51	A75SF4-84*6D	\$ 3,300.00	ACE	3.53
A750SY4-70**	\$ 81,446.00	WDAE	3.79	A75NSP-84*	\$ 1,035.00	AAE	3.15	A75SFP-84*6D	\$ 2,475.00	ACE	3.53
A750SYX-70**	\$ 88,725.00	WDAE	3.79	A75NSR1-84*	\$ 1,905.00	AAE	3.18	A75SFX-84*6D	\$ 4,020.00	ACE	3.53
A753000RT-84	\$ 396.00	AA	1.10	A75NSR2-84*	\$ 2,813.00	AAE	3.19	A75SG-84**	\$ 4,766.00	WDA	3.76
A75M-30-11-84	\$ 1,155.00	AA	1.3	A75NSR3-84*	\$ 2,813.00	AAE	3.19	A75SG1-84**	\$ 5,324.00	WDAE	3.76
A75N3-30-11-84	\$ 413.00	AA	1.11	A75NSR4-84*	\$ 3,113.00	AAE	3.19	A75SG2-84**	\$ 6,674.00	WDAE	3.77
A75N3M-11-84	\$ 1,155.00	AA	1.11	A75NSRF1-84*6C	\$ 3,176.00	ACE	3.54	A75SG3-84**	\$ 6,674.00	WDAE	3.77
A75N3R-11-84	\$ 1,298.00	AA	1.11	A75NSRF2-84*6C	\$ 3,589.00	ACE	3.55	A75SG4-84**	\$ 7,079.00	WDAE	3.77
A75N3S-84*	\$ 563.00	AA	3.14	A75NSRF3-84*6C	\$ 4,013.00	ACE	3.55	A75SGX-84**	\$ 8,438.00	WDAE	3.77
A75N3SA-84*	\$ 5,787.00	RVA	3.74	A75NSRF4-84*6C	\$ 4,013.00	ACE	3.55	A75SH-84**	\$ 3,708.00	PWA	3.80
A75N3SG-84**	\$ 4,766.00	WDA	3.76	A75NSRF5-84*6C	\$ 3,589.00	ACE	3.54	A75SH1-84**	\$ 3,960.00	PWAE	3.80
A75N3SH-84**	\$ 3,708.00	PWA	3.80	A75NSRF6-84*6C	\$ 4,013.00	ACE	3.54	A75SH2-84**	\$ 5,310.00	PWAE	3.81
A75N3SR-84*	\$ 1,620.00	AA	3.18	A75NSRF7-84*6C	\$ 3,776.00	ACE	3.55	A75SH3-84**	\$ 5,310.00	PWAE	3.81
A75N3ST-84*1*	\$ 2,307.00	AA	3.20	A75NSRF8-84*6D	\$ 4,200.00	ACE	3.55	A75SH4-84**	\$ 5,715.00	PWAE	3.81
A75N3ST-84*2*	\$ 1,692.00	AA	3.22	A75NSRFP-84*6C	\$ 3,311.00	ACE	3.55	A75SHX-84**	\$ 6,540.00	PWAE	3.81
A75N3SY-84**	\$ 7,781.00	WDA	3.78	A75NSRFP-84*6D	\$ 3,735.00	ACE	3.55	A75SM1-84***	\$ 2,550.00	ACE	3.56
A75NS1-84*	\$ 975.00	AAE	3.14	A75NSRFX-84*6C	\$ 4,651.00	ACE	3.55	A75SM2-84***	\$ 2,880.00	ACE	3.57
A75NS2-84*	\$ 1,058.00	AAE	3.15	A75NSRFX-84*6D	\$ 5,075.00	ACE	3.55	A75SM3-84***	\$ 2,880.00	ACE	3.56
A75NS3-84*	\$ 1,058.00	AAE	3.14	A75NSRM1-84***	\$ 3,705.00	ACE	3.62	A75SM4-84***	\$ 3,225.00	ACE	3.57
A75NS4-84*	\$ 1,425.00	AAE	3.15	A75NSRM2-84**	\$ 4,035.00	ACE	3.63	A75SM7-84***	\$ 6,850.00	AXE	3.57
A75NS7-84*	\$ 3,123.00	AXE	3.15	A75NSRM3-84***	\$ 4,035.00	ACE	3.62	A75SMP-84***	\$ 2,520.00	ACE	3.57
A75NSA1-84*	\$ 6,471.00	RVAE	3.74	A75NSRMP-84***	\$ 4,200.00	ACE	3.63	A75SMX-84***	\$ 4,055.00	ACE	3.57
A75NSA2-84*	\$ 8,181.00	RVAE	3.75	A75NSRM4-84***	\$ 3,855.00	ACE	3.63	A75SN1-84*	\$ 2,295.00	ACE	3.50
A75NSA3-84*	\$ 8,181.00	RVAE	3.75	A75NSRMX-84***	\$ 5,210.00	ACE	3.63	A75SN2-84*	\$ 2,775.00	ACE	3.51
A75NSA4-84*	\$ 9,261.00	RVAE	3.75	A75NSRNP-84*	\$ 2,250.00	AAE	3.19	A75SN3-84*	\$ 2,775.00	ACE	3.50
A75NSAX-84*	\$ 10,988.00	RVAE	3.75	A75NSRNX-84*	\$ 3,600.00	AAE	3.19	A75SN4-84*	\$ 3,015.00	ACE	3.51
A75NSF1-84*6C	\$ 2,021.00	ACE	3.52	A75NST1-84*1*	\$ 2,589.00	AAE	3.20	A75SNP-84*	\$ 2,415.00	ACE	3.51
A75NSF1-84*6D	\$ 2,445.00	ACE	3.52	A75NST1-84*2*	\$ 1,977.00	AAE	3.22	A75SNX-84*	\$ 4,000.00	ACE	3.51
A75NSF2-84*6C	\$ 2,434.00	ACE	3.53	A75NST2-84*1*	\$ 3,500.00	AAE	3.21	A75SP-84*	\$ 1,035.00	AAE	3.15
A75NSF2-84*6D	\$ 2,858.00	ACE	3.53	A75NST2-84*2*	\$ 2,885.00	AAE	3.23	A75SR-84*	\$ 1,620.00	AA	3.18
A75NSF3-84*6C	\$ 2,434.00	ACE	3.52	A75NST3-84*1*	\$ 3,500.00	AAE	3.21	A75SR1-84*	\$ 1,905.00	AAE	3.18
A75NSF3-84*6D	\$ 2,858.00	ACE	3.52	A75NST3-84*2*	\$ 2,885.00	AAE	3.23	A75SR2-84*	\$ 2,813.00	AAE	3.19
A75NSF4-84*6C	\$ 2,876.00	ACE	3.53	A75NST4-84*1*	\$ 3,788.00	AAE	3.21	A75SR3-84*	\$ 2,813.00	AAE	3.19
A75NSF4-84*6D	\$ 3,300.00	ACE	3.53	A75NST4-84*2*	\$ 3,090.00	AAE	3.23	A75SR4-84*	\$ 3,113.00	AAE	3.19
A75NSFP-84*6C	\$ 2,051.00	ACE	3.53	A75NSTP-84*1*	\$ 2,835.00	AAE	3.21	A75SRF1-84*6D	\$ 3,600.00	ACE	3.54
A75NSFP-84*6D	\$ 2,475.00	ACE	3.53	A75NSTP-84*2*	\$ 2,200.00	AAE	3.23	A75SRF2-84*6D	\$ 4,013.00	ACE	3.55
A75NSFX-84*6C	\$ 3,596.00	ACE	3.53	A75NSTX-84*1*	\$ 4,287.00	AAE	3.21	A75SRF3-84*6D	\$ 4,013.00	ACE	3.54
A75NSFX-84*6D	\$ 4,020.00	ACE	3.53	A75NSTX-84*2*	\$ 3,672.00	AAE	3.23	A75SRF4-84*6D	\$ 4,200.00	ACE	3.55
A75NSG1-84**	\$ 5,324.00	WDAE	3.76	A75NSX-84*	\$ 2,010.00	AAE	3.15	A75SRFP-84*6D	\$ 3,735.00	ACE	3.55
A75NSG2-84**	\$ 6,674.00	WDAE	3.77	A75NSY1-84**	\$ 8,339.00	WDAE	3.78	A75SRFX-84*6D	\$ 5,075.00	ACE	3.55
A75NSG3-84**	\$ 6,674.00	WDAE	3.77	A75NSY2-84**	\$ 9,689.00	WDAE	3.79	A75SRM1-84***	\$ 2,940.00	ACE	3.60
A75NSG4-84**	\$ 7,079.00	WDAE	3.77	A75NSY3-84**	\$ 9,689.00	WDAE	3.79	A75SRM2-84***	\$ 4,035.00	ACE	3.61
A75NSGX-84**	\$ 8,438.00	WDAE	3.77	A75NSY4-84**	\$ 10,094.00	WDAE	3.79	A75SRM3-84***	\$ 4,035.00	ACE	3.60
A75NSH1-84**	\$ 3,960.00	PWAE	3.80	A75NSYX-84**	\$ 11,138.00	WDAE	3.79	A75SRM4-84***	\$ 4,200.00	ACE	3.61
A75NSH2-84**	\$ 5,310.00	PWAE	3.81	A75R-30-11-84	\$ 1,298.00	AA	1.3	A75SRMP-84***	\$ 3,855.00	ACE	3.61
A75NSH3-84**	\$ 5,310.00	PWAE	3.81	A75S-84*	\$ 563.00	AA	3.14	A75SRMX-84***	\$ 5,210.00	ACE	3.61
A75NSH4-84**	\$ 5,715.00	PWAE	3.81	A75S1-84*	\$ 975.00	AAE	3.14	A75SRP-84*	\$ 2,250.00	AAE	3.19
A75NSHX-84**	\$ 6,540.00	PWAE	3.81	A75S2-84*	\$ 1,058.00	AAE	3.15	A75SRX-84*	\$ 3,600.00	AAE	3.19
A75NSM1-84***	\$ 2,550.00	ACE	3.58	A75S3-84*	\$ 1,058.00	AAE	3.14	A75SS-84*	\$ 563.00	AA	3.16
A75NSM2-84***	\$ 2,880.00	ACE	3.59	A75S4-84*	\$ 1,425.00	AAE	3.15	A75SS1-84*	\$ 975.00	AAE	3.16
A75NSM3-84***	\$ 2,880.00	ACE	3.58	A75S7-84*	\$ 3,900.00	AXE	3.15	A75SS2-84*	\$ 1,058.00	AAE	3.17
A75NSM4-84***	\$ 3,225.00	ACE	3.59	A75SA-84*	\$ 5,787.00	RVA	3.74	A75SS3-84*	\$ 1,058.00	AAE	3.17
A75NSM7-84***	\$ 6,850.00	AXE	3.59	A75SA1-84*	\$ 6,471.00	RVAE	3.74	A75SS4-84*	\$ 1,425.00	AAE	3.17

A75SSP-84* – A9NSRMP-84***

Alphanumeric

0

Catalog number	List price	Discount schedule	Page number	Catalog number	List price	Discount schedule	Page number	Catalog number	List price	Discount schedule	Page number
A75SSP-84*	\$ 1,035.00	AAE	3.17	A95SH2-84**	\$ 8,500.00	PWAE	3.81	A95SY1-84**	\$ 13,000.00	WDAE	3.78
A75SSX-84*	\$ 2,010.00	AAE	3.17	A95SH3-84**	\$ 8,500.00	PWAE	3.81	A95SY2-84**	\$ 14,900.00	WDAE	3.79
A75ST-84*1*	\$ 2,307.00	AA	3.20	A95SH4-84**	\$ 8,700.00	PWAE	3.81	A95SY3-84**	\$ 14,900.00	WDAE	3.79
A75ST-84*2*	\$ 1,692.00	AA	3.22	A95SHX-84**	\$ 9,300.00	PWAE	3.81	A95SY4-84**	\$ 15,900.00	WDAE	3.79
A75ST1-84*1*	\$ 2,592.00	AAE	3.20	A95SM1-84***	\$ 2,750.00	ACE	3.56	A95SYX-84**	\$ 17,000.00	WDAE	3.79
A75ST1-84*2*	\$ 1,977.00	AAE	3.22	A95SM2-84***	\$ 3,125.00	ACE	3.57	A9M-30-01-84	\$ 255.00	AA	1.3
A75ST2-84*1*	\$ 3,500.00	AAE	3.21	A95SM3-84***	\$ 2,880.00	ACE	3.56	A9M-30-10-84	\$ 255.00	AA	1.3
A75ST2-84*2*	\$ 2,885.00	AAE	3.23	A95SM4-84***	\$ 3,800.00	ACE	3.57	A9N00-30-10-84	\$ 78.00	AA	1.11
A75ST3-84*1*	\$ 3,500.00	AAE	3.21	A95SM7-84***	\$ 7,940.00	AXE	3.57	A9N00R-10-84	\$ 315.00	AA	1.11
A75ST3-84*2*	\$ 2,885.00	AAE	3.23	A95SMP-84***	\$ 3,250.00	ACE	3.57	A9N00S-84*	\$ 165.00	AA	3.14
A75ST4-84*1*	\$ 3,788.00	AAE	3.21	A95SMX-84***	\$ 5,200.00	ACE	3.57	A9N00SP-84*	\$ 315.00	AAE	3.17
A75ST4-84*2*	\$ 3,090.00	AAE	3.23	A95SN1-84*	\$ 2,650.00	ACE	3.50	A9N00SR-84*	\$ 342.00	AA	3.18
A75STP-84*1*	\$ 2,835.00	AAE	3.21	A95SN2-84*	\$ 3,200.00	ACE	3.51	A9N00SS-84*	\$ 165.00	AA	3.16
A75STP-84*2*	\$ 2,200.00	AAE	3.23	A95SN3-84*	\$ 3,200.00	ACE	3.50	A9N00SS1-84*	\$ 255.00	AAE	3.16
A75STX-84*1*	\$ 4,287.00	AAE	3.21	A95SN4-84*	\$ 3,650.00	ACE	3.51	A9N00SS2-84*	\$ 330.00	AAE	3.17
A75STX-84*2*	\$ 3,672.00	AAE	3.23	A95SNP-84*	\$ 2,950.00	ACE	3.51	A9N00SS3-84*	\$ 330.00	AAE	3.17
A75SX-84*	\$ 2,010.00	AAE	3.15	A95SNX-84*	\$ 4,800.00	ACE	3.51	A9N00SS4-84*	\$ 495.00	AAE	3.17
A75SY-84**	\$ 7,781.00	WDA	3.78	A95SP-84*	\$ 1,410.00	AAE	3.15	A9N00ST-84*1*	\$ 504.00	AA	3.20
A75SY1-84**	\$ 8,339.00	WDAE	3.78	A95SR-84*	\$ 1,697.00	AA	3.18	A9N00ST-84*2*	\$ 396.00	AA	3.22
A75SY2-84**	\$ 9,689.00	WDAE	3.79	A95SR1-84*	\$ 2,767.00	AAE	3.18	A9N00SX-84*	\$ 645.00	AAE	3.17
A75SY3-84**	\$ 9,689.00	WDAE	3.79	A95SR2-84*	\$ 3,427.00	AAE	3.19	A9NS1-84*	\$ 255.00	AAE	3.14
A75SY4-84**	\$ 10,094.00	WDAE	3.79	A95SR3-84*	\$ 3,427.00	AAE	3.19	A9NS2-84*	\$ 330.00	AAE	3.15
A75SYX-84**	\$ 11,138.00	WDAE	3.79	A95SR4-84*	\$ 3,697.00	AAE	3.19	A9NS3-84*	\$ 330.00	AAE	3.14
A9-22-00-84	\$ 120.00	AA	1.13	A95SRF1-84*6D	\$ 3,890.00	ACE	3.54	A9NS4-84*	\$ 495.00	AAE	3.15
A9-30-01-84	\$ 78.00	AA	1.3	A95SRF2-84*6D	\$ 4,700.00	ACE	3.55	A9NS7-84*	\$ 1,200.00	AXE	3.15
A9-30-10-84	\$ 78.00	AA	1.3	A95SRF3-84*6D	\$ 4,700.00	ACE	3.54	A9NSF1-84*6A	\$ 885.00	ACE	3.52
A9-40-00-84	\$ 120.00	AA	1.13	A95SRF4-84*6D	\$ 5,100.00	ACE	3.55	A9NSF2-84*6A	\$ 1,065.00	ACE	3.53
A900M-10-84	\$ 255.00	AA	1.11	A95SRFP-84*6D	\$ 4,125.00	ACE	3.55	A9NSF3-84*6A	\$ 1,065.00	ACE	3.52
A93001RT-84	\$ 81.00	AA	1.10	A95SRFX-84*6D	\$ 6,250.00	ACE	3.55	A9NSF4-84*6A	\$ 1,350.00	ACE	3.53
A93010RT-84	\$ 81.00	AA	1.10	A95SRM1-84***	\$ 3,705.00	ACE	3.60	A9NSFP-84*6A	\$ 1,005.00	ACE	3.53
A95-30-11-84	\$ 450.00	AA	1.3	A95SRM2-84***	\$ 5,100.00	ACE	3.61	A9NSFX-84*6A	\$ 1,800.00	ACE	3.53
A953000RT-84	\$ 466.00	AA	1.10	A95SRM3-84***	\$ 5,100.00	ACE	3.60	A9NSM1-84***	\$ 930.00	ACE	3.58
A95M-30-11-84	\$ 1,230.00	AA	1.3	A95SRM4-84***	\$ 5,500.00	ACE	3.61	A9NSM2-84***	\$ 1,110.00	ACE	3.59
A95R-30-11-84	\$ 1,425.00	AA	1.3	A95SRMP-84***	\$ 4,450.00	ACE	3.61	A9NSM3-84***	\$ 1,110.00	ACE	3.58
A95S-84*	\$ 735.00	AA	3.14	A95SRMX-84***	\$ 7,200.00	ACE	3.61	A9NSM4-84***	\$ 1,260.00	ACE	3.59
A95S1-84*	\$ 1,140.00	AAE	3.14	A95SRP-84*	\$ 3,025.00	AAE	3.19	A9NSM7-84***	\$ 2,660.00	AXE	3.59
A95S2-84*	\$ 1,485.00	AAE	3.15	A95SRX-84*	\$ 4,276.00	AAE	3.19	A9NSMP-84***	\$ 1,050.00	ACE	3.59
A95S3-84*	\$ 1,485.00	AAE	3.14	A95SS-84*	\$ 735.00	AA	3.16	A9NSMX-84***	\$ 1,835.00	ACE	3.59
A95S4-84*	\$ 2,070.00	AAE	3.15	A95SS1-84*	\$ 1,140.00	AAE	3.16	A9NSN1-84*	\$ 825.00	ACE	3.50
A95S7-84*	\$ 5,510.00	AXE	3.15	A95SS2-84*	\$ 1,485.00	AAE	3.17	A9NSN2-84*	\$ 1,005.00	ACE	3.51
A95SA-84*	\$ 9,300.00	RVA	3.74	A95SS3-84*	\$ 1,485.00	AAE	3.17	A9NSN3-84*	\$ 1,005.00	ACE	3.50
A95SA1-84*	\$ 9,800.00	RVAE	3.74	A95SS4-84*	\$ 2,070.00	AAE	3.17	A9NSN4-84*	\$ 1,290.00	ACE	3.51
A95SA2-84*	\$ 11,200.00	RVAE	3.75	A95SSP-84*	\$ 1,075.00	AAE	3.17	A9NSNP-84*	\$ 945.00	ACE	3.51
A95SA3-84*	\$ 11,200.00	RVAE	3.75	A95SSX-84*	\$ 2,783.00	AAE	3.17	A9NSNX-84*	\$ 1,600.00	ACE	3.51
A95SA4-84*	\$ 12,400.00	RVAE	3.75	A95ST-84*1*	\$ 2,495.00	AA	3.20	A9NSP-84*	\$ 315.00	AAE	3.15
A95SAX-84*	\$ 13,600.00	RVAE	3.75	A95ST-84*2*	\$ 1,795.00	AA	3.22	A9NSR1-84*	\$ 510.00	AAE	3.18
A95SF1-84*6D	\$ 2,590.00	ACE	3.52	A95ST1-84*1*	\$ 2,950.00	AAE	3.20	A9NSR2-84*	\$ 630.00	AAE	3.19
A95SF2-84*6D	\$ 3,290.00	ACE	3.53	A95ST1-84*2*	\$ 2,450.00	AAE	3.22	A9NSR3-84*	\$ 630.00	AAE	3.19
A95SF3-84*6D	\$ 3,290.00	ACE	3.52	A95ST2-84*1*	\$ 3,900.00	AAE	3.21	A9NSR4-84*	\$ 810.00	AAE	3.19
A95SF4-84*6D	\$ 3,950.00	ACE	3.53	A95ST2-84*2*	\$ 3,500.00	AAE	3.23	A9NSRF1-84*6A	\$ 1,140.00	ACE	3.54
A95SFP-84*6D	\$ 3,125.00	ACE	3.53	A95ST3-84*1*	\$ 3,900.00	AAE	3.21	A9NSRF2-84*6A	\$ 1,320.00	ACE	3.55
A95SFX-84*6D	\$ 4,990.00	ACE	3.53	A95ST3-84*2*	\$ 3,500.00	AAE	3.23	A9NSRF3-84*6A	\$ 1,320.00	ACE	3.54
A95SG-84**	\$ 6,600.00	WDA	3.76	A95ST4-84*1*	\$ 4,250.00	AAE	3.21	A9NSRF4-84*6A	\$ 1,425.00	ACE	3.55
A95SG1-84**	\$ 6,900.00	WDAE	3.76	A95ST4-84*2*	\$ 3,700.00	AAE	3.23	A9NSRFP-84*6A	\$ 1,275.00	ACE	3.55
A95SG2-84**	\$ 7,875.00	WDAE	3.77	A95STP-84*1*	\$ 3,200.00	AAE	3.21	A9NSRFX-84*6A	\$ 1,955.00	ACE	3.55
A95SG3-84**	\$ 7,875.00	WDAE	3.77	A95STP-84*2*	\$ 2,650.00	AAE	3.23	A9NSRM1-84***	\$ 1,185.00	ACE	3.62
A95SG4-84**	\$ 8,205.00	WDAE	3.77	A95STX-84*1*	\$ 4,850.00	AAE	3.21	A9NSRM2-84***	\$ 1,365.00	ACE	3.63
A95SGX-84**	\$ 9,625.00	WDAE	3.77	A95STX-84*2*	\$ 3,950.00	AAE	3.23	A9NSRM3-84***	\$ 1,365.00	ACE	3.62
A95SH-84**	\$ 6,700.00	PWA	3.80	A95SX-84*	\$ 2,783.00	AAE	3.15	A9NSRM4-84***	\$ 1,515.00	ACE	3.63
A95SH1-84**	\$ 6,950.00	PWAE	3.80	A95SY-84**	\$ 12,000.00	WDA	3.78	A9NSRMP-84***	\$ 1,320.00	ACE	3.63

A9NSRMX-84*** – AE145N4R-11-70

Catalog number	List price	Discount schedule	Page number	Catalog number	List price	Discount schedule	Page number	Catalog number	List price	Discount schedule	Page number
A9NSRMX-84***	\$ 2,090.00	ACE	3.63	A9SRM3-84***	\$ 1,365.00	ACE	3.60	AA4D175B7A	-	F3	19.29
A9NSRP-84*	\$ 608.00	AAE	3.19	A9SRM4-84***	\$ 1,515.00	ACE	3.61	AA4D200B8A	-	F3	19.29
A9NSRX-84*	\$ 1,125.00	AAE	3.19	A9SRMP-84***	\$ 1,320.00	ACE	3.61	AA4D225B9A	-	F3	19.29
A9NST1-84*1*	\$ 690.00	AAE	3.20	A9SRMX-84***	\$ 2,090.00	ACE	3.61	AA4D250B10A	-	F3	19.29
A9NST1-84*2*	\$ 582.00	AAE	3.22	A9SRP-84*	\$ 608.00	AAE	3.19	AA4D300B12A	-	F3	19.29
A9NST2-84*1*	\$ 810.00	AAE	3.21	A9SRX-84*	\$ 1,125.00	AAE	3.19	AA4D50B3B	-	F3	19.29
A9NST2-84*2*	\$ 702.00	AAE	3.23	A9SS-84*	\$ 165.00	AA	3.16	AA4D75B5A	-	F3	19.29
A9NST3-84*1*	\$ 810.00	AAE	3.21	A9SS1-84*	\$ 255.00	AAE	3.16	AA4G100B5A	-	F3	19.29
A9NST3-84*2*	\$ 702.00	AAE	3.23	A9SS2-84*	\$ 330.00	AAE	3.17	AA4G125B5A	-	F3	19.29
A9NST4-84*1*	\$ 1,020.00	AAE	3.21	A9SS3-84*	\$ 330.00	AAE	3.17	AA4G150B6A	-	F3	19.29
A9NST4-84*2*	\$ 915.00	AAE	3.23	A9SS4-84*	\$ 495.00	AAE	3.17	AA4G175B7A	-	F3	19.29
A9NSTP-84*1*	\$ 788.00	AAE	3.21	A9SSD-84*	\$ 233.00	AAE	3.24	AA4G200B8A	-	F3	19.29
A9NSTP-84*2*	\$ 680.00	AAE	3.23	A9SSD-84*A	\$ 278.00	AAE	3.24	AA4G225B9A	-	F3	19.29
A9NSTX-84*1*	\$ 1,305.00	AAE	3.21	A9SSD-84*R	\$ 240.00	AAE	3.24	AA4G250B10A	-	F3	19.29
A9NSTX-84*2*	\$ 1,197.00	AAE	3.23	A9SSP-84*	\$ 315.00	AAE	3.17	AA4G300B12A	-	F3	19.29
A9NSX-84*	\$ 645.00	AAE	3.15	A9SSX-84*	\$ 645.00	AAE	3.17	AA4G50B3B	-	F3	19.29
A9R-03-10-84	\$ 315.00	AA	1.3	A9ST-84*1*	\$ 504.00	AA	3.20	AA4G75B5A	-	F3	19.29
A9R-30-10-84	\$ 315.00	AA	1.3	A9ST-84*2*	\$ 396.00	AA	3.22	AA4R100B5A	-	F3	19.29
A9S-84*	\$ 165.00	AA	3.14	A9ST1-84*1*	\$ 690.00	AAE	3.20	AA4R125B5A	-	F3	19.29
A9S1-84*	\$ 255.00	AAE	3.14	A9ST1-84*2*	\$ 582.00	AAE	3.22	AA4R150B6A	-	F3	19.29
A9S2-84*	\$ 330.00	AAE	3.15	A9ST2-84*1*	\$ 810.00	AAE	3.21	AA4R175B7A	-	F3	19.29
A9S3-84*	\$ 330.00	AAE	3.14	A9ST2-84*2*	\$ 702.00	AAE	3.23	AA4R200B8A	-	F3	19.29
A9S4-84*	\$ 495.00	AAE	3.15	A9ST3-84*1*	\$ 810.00	AAE	3.21	AA4R225B9A	-	F3	19.29
A9S7-84*	\$ 1,500.00	AXE	3.15	A9ST3-84*2*	\$ 702.00	AAE	3.23	AA4R250B10A	-	F3	19.29
A9SD-84*	\$ 233.00	AAE	3.24	A9ST4-84*1*	\$ 1,020.00	AAE	3.21	AA4R300B12A	-	F3	19.29
A9SD-84*A	\$ 278.00	AAE	3.24	A9ST4-84*2*	\$ 915.00	AAE	3.23	AA4R50B3B	-	F3	19.29
A9SD-84*R	\$ 240.00	AAE	3.24	A9STP-84*1*	\$ 788.00	AAE	3.21	AA4R75B5A	-	F3	19.29
A9SF1-84*6A	\$ 885.00	ACE	3.52	A9STP-84*2*	\$ 680.00	AAE	3.23	AA6D100B5A	-	F3	19.29
A9SF2-84*6A	\$ 1,065.00	ACE	3.53	A9STX-84*1*	\$ 1,305.00	AAE	3.21	AA6D125B5A	-	F3	19.29
A9SF3-84*6A	\$ 1,065.00	ACE	3.52	A9STX-84*2*	\$ 1,197.00	AAE	3.23	AA6D150B6A	-	F3	19.29
A9SF4-84*6A	\$ 1,350.00	ACE	3.53	A9SX-84*	\$ 645.00	AAE	3.15	AA6D175B7A	-	F3	19.29
A9SFP-84*6A	\$ 1,005.00	ACE	3.53	AA1-110	\$ 75.00	MA	5.4	AA6D200B8A	-	F3	19.29
A9SFX-84*6A	\$ 1,800.00	ACE	3.53	AA1-230	\$ 75.00	MA	5.4	AA6D225B9A	-	F3	19.29
A9SM1-84***	\$ 930.00	ACE	3.56	AA1-24	\$ 75.00	MA	5.4	AA6D250B10A	-	F3	19.29
A9SM2-84***	\$ 1,110.00	ACE	3.57	AA1-400	\$ 75.00	MA	5.4	AA6D300B12A	-	F3	19.29
A9SM3-84***	\$ 1,110.00	ACE	3.56	AA2D100B8A	-	F3	19.29	AA6G100B5A	-	F3	19.29
A9SM4-84***	\$ 1,260.00	ACE	3.57	AA2D125B10A	-	F3	19.29	AA6G125B5A	-	F3	19.29
A9SM7-84***	\$ 2,660.00	AXE	3.57	AA2D150B12A	-	F3	19.29	AA6G150B6A	-	F3	19.29
A9SMP-84***	\$ 1,050.00	ACE	3.57	AA2D25B5A	-	F3	19.29	AA6G175B7A	-	F3	19.29
A9SMX-84***	\$ 1,835.00	ACE	3.57	AA2D50B5A	-	F3	19.29	AA6G200B8A	-	F3	19.29
A9SN1-84*	\$ 825.00	ACE	3.50	AA2D75B6A	-	F3	19.29	AA6G225B9A	-	F3	19.29
A9SN2-84*	\$ 1,005.00	ACE	3.51	AA2G100B8A	-	F3	19.29	AA6G250B10A	-	F3	19.29
A9SN3-84*	\$ 1,005.00	ACE	3.50	AA2G125B10A	-	F3	19.29	AA6G300B12A	-	F3	19.29
A9SN4-84*	\$ 1,290.00	ACE	3.51	AA2G150B12A	-	F3	19.29	AA6R100B5A	-	F3	19.29
A9SNP-84*	\$ 945.00	ACE	3.51	AA2G25B5A	-	F3	19.29	AA6R125B5A	-	F3	19.29
A9SNX-84*	\$ 1,600.00	ACE	3.51	AA2G50B5A	-	F3	19.29	AA6R150B6A	-	F3	19.29
A9SP-84*	\$ 315.00	AAE	3.15	AA2G75B6A	-	F3	19.29	AA6R175B7A	-	F3	19.29
A9SR-84*	\$ 342.00	AA	3.18	AA2R100B8A	-	F3	19.29	AA6R200B8A	-	F3	19.29
A9SR1-84*	\$ 510.00	AAE	3.18	AA2R125B10A	-	F3	19.29	AA6R225B9A	-	F3	19.29
A9SR2-84*	\$ 630.00	AAE	3.19	AA2R150B12A	-	F3	19.29	AA6R250B10A	-	F3	19.29
A9SR3-84*	\$ 630.00	AAE	3.19	AA2R25B5A	-	F3	19.29	AA6R300B12A	-	F3	19.29
A9SR4-84*	\$ 810.00	AAE	3.19	AA2R50B5A	-	F3	19.29	AE110-30-11-81	\$ 690.00	AA	1.5
A9SRF1-84*6A	\$ 1,140.00	ACE	3.54	AA2R75B6A	-	F3	19.29	AE1103000RT-81	\$ 753.00	AA	1.10
A9SRF2-84*6A	\$ 1,320.00	ACE	3.55	AA4-110	\$ 93.00	MA	5.17	AE110M-30-11-81	\$ 1,785.00	AA	1.5
A9SRF3-84*6A	\$ 1,320.00	ACE	3.54	AA4-24	\$ 93.00	MA	5.17	AE110R-30-11-81	\$ 2,048.00	AA	1.5
A9SRF4-84*6A	\$ 1,425.00	ACE	3.55	AA4-240	\$ 93.00	MA	5.17	AE12-30-11-81	\$ 124.00	AA	1.5
A9SRFP-84*6A	\$ 1,275.00	ACE	3.55	AA4-415	\$ 93.00	MA	5.17	AE123000RT-81	\$ 97.00	AA	1.10
A9SRFX-84*6A	\$ 1,955.00	ACE	3.55	AA4D100B5A	-	F3	19.29	AE12M-30-11-81	\$ 395.00	AA	1.5
A9SRM1-84***	\$ 1,185.00	ACE	3.60	AA4D125B5A	-	F3	19.29	AE12R-30-11-81	\$ 455.00	AA	1.5
A9SRM2-84***	\$ 1,365.00	ACE	3.61	AA4D150B6A	-	F3	19.29	AE145N4R-11-70	\$ 2,670.00	AEA	1.12

AE16-30-11-81 – AE16-30-11-81

Alphanumeric

0

Catalog number	List price	Discount schedule	Page number	Catalog number	List price	Discount schedule	Page number	Catalog number	List price	Discount schedule	Page number
AE16-30-11-81	\$ 142.00	AA	1.5	AF145M-30-11-70	\$ 2,655.00	AEA	1.9	AGS-CP10	\$ 214.00	J	18.2
AE163000RT-81	\$ 116.00	AA	1.10	AF145N4-3011-70	\$ 1,110.00	AEA	1.12	AGS-CP15	\$ 281.00	J	18.2
AE16M-30-11-81	\$ 425.00	AA	1.5	AF145N4M-11-70	\$ 2,655.00	AEA	1.12	AGS-CP2	\$ 105.00	J	18.2
AE16N0-30-11-81	\$ 142.00	AA	1.12	AF145R-30-11-70	\$ 2,670.00	AEA	1.9	AGS-CP20	\$ 356.00	J	18.2
AE16N0M-11-81	\$ 425.00	AA	1.12	AF1650-30-11-70	\$ 10,230.00	AEA	1.9	AGS-CP4	\$ 134.00	J	18.2
AE16N0R-11-81	\$ 493.00	AA	1.12	AF1650N83011-70	\$ 10,230.00	AEA	1.11	AGS-CP6	\$ 160.00	J	18.2
AE16R-30-11-81	\$ 493.00	AA	1.5	AF185-30-11-70	\$ 1,635.00	AEA	1.9	AGS-CP8	\$ 189.00	J	18.2
AE26-30-11-81	\$ 223.00	AA	1.5	AF185M-30-11-70	\$ 3,870.00	AEA	1.9	AGS-CS240	\$ 2,452.00	J	18.2
AE260N5R-11-70	\$ 5,070.00	AEA	1.12	AF185R-30-11-70	\$ 3,885.00	AEA	1.9	AGS-DP10	\$ 314.00	J	18.2
AE263000RT-81	\$ 199.00	AA	1.10	AF210-30-11-70	\$ 1,980.00	AEA	1.9	AGS-DP15	\$ 381.00	J	18.2
AE26M-30-11-81	\$ 485.00	AA	1.5	AF210M-30-11-70	\$ 4,545.00	AEA	1.9	AGS-DP2	\$ 212.00	J	18.2
AE26N1-30-11-81	\$ 223.00	AA	1.12	AF210R-30-11-70	\$ 4,560.00	AEA	1.9	AGS-DP20	\$ 448.00	J	18.2
AE26N1M-11-81	\$ 485.00	AA	1.12	AF260-30-11-70	\$ 2,235.00	AEA	1.9	AGS-DP30	\$ 591.00	J	18.2
AE26N1R-11-81	\$ 560.00	AA	1.12	AF260M-30-11-70	\$ 5,055.00	AEA	1.9	AGS-DP4	\$ 235.00	J	18.2
AE26R-30-11-81	\$ 560.00	AA	1.5	AF260N5-3011-70	\$ 2,235.00	AEA	1.12	AGS-DP6	\$ 260.00	J	18.2
AE30-30-11-81	\$ 292.00	AA	1.5	AF260N5M-11-70	\$ 5,055.00	AEA	1.12	AGS-DP8	\$ 289.00	J	18.2
AE30M-30-11-81	\$ 628.00	AA	1.5	AF260R-30-11-70	\$ 5,070.00	AEA	1.9	AGS-FMS	\$ 128.00	J	18.2
AE30R-30-11-81	\$ 703.00	AA	1.5	AF300-30-11-70	\$ 2,385.00	AEA	1.9	AGS-MB	\$ 10.00	J	18.2
AE40-30-11-81	\$ 337.00	AA	1.5	AF300M-30-11-70	\$ 6,030.00	AEA	1.9	AL110	\$ 224.00	CB8	14.42
AE40M-30-11-81	\$ 720.00	AA	1.5	AF300R-30-11-70	\$ 6,045.00	AEA	1.9	AL12	\$ 224.00	CB8	14.42
AE40R-30-11-81	\$ 830.00	AA	1.5	AF400-30-11-70	\$ 3,120.00	AEA	1.9	AL12-30-01-81	\$ 135.00	AA	1.7
AE45-22-00-86	\$ 420.00	AA	1.13	AF400M-30-11-70	\$ 6,705.00	AEA	1.9	AL12-30-10-81	\$ 135.00	AA	1.7
AE45-40-00-81	\$ 420.00	AA	1.13	AF400R-30-11-70	\$ 6,720.00	AEA	1.9	AL12M-30-01-81	\$ 417.00	AA	1.7
AE50-30-11-81	\$ 375.00	AA	1.5	AF45-22-00-70	\$ 385.00	AA	1.14	AL12M-30-10-81	\$ 417.00	AA	1.7
AE50-40-00-81	\$ 473.00	AA	1.13	AF45-40-00-70	\$ 385.00	AA	1.14	AL12R-30-01-81	\$ 477.00	AA	1.7
AE503000RT-81	\$ 356.00	AA	1.10	AF460-30-11-70	\$ 4,425.00	AEA	1.9	AL12R-30-10-81	\$ 477.00	AA	1.7
AE50M-30-11-81	\$ 803.00	AA	1.5	AF460M-30-11-70	\$ 13,275.00	AEA	1.9	AL12Z-30-01-15	\$ 135.00	AA	1.7
AE50N2-30-11-81	\$ 375.00	AA	1.12	AF460N6-3011-70	\$ 4,425.00	AEA	1.11	AL12Z-30-10-15	\$ 135.00	AA	1.7
AE50N2M-11-81	\$ 803.00	AA	1.12	AF460N6M-11-70	\$ 13,275.00	AEA	1.11	AL12ZM-30-01-15	\$ 417.00	AA	1.7
AE50N2R-11-81	\$ 930.00	AA	1.12	AF460N6R-11-70	\$ 13,290.00	AEA	1.11	AL12ZM-30-10-15	\$ 417.00	AA	1.7
AE50R-30-11-81	\$ 930.00	AA	1.5	AF460R-30-11-70	\$ 13,290.00	AEA	1.9	AL12ZR-30-01-15	\$ 477.00	AA	1.7
AE63-30-11-81	\$ 477.00	AA	1.5	AF460W-30-11-70	\$ 4,425.00	AEA	1.116	AL12ZR-30-10-15	\$ 477.00	AA	1.7
AE633000RT-81	\$ 459.00	AA	1.10	AF50-30-11-70	\$ 450.00	AA	1.9	AL16-22-00-81	\$ 172.00	AA	1.13
AE63M-30-11-81	\$ 1,080.00	AA	1.5	AF50-40-00-70	\$ 435.00	AA	1.14	AL16-30-01-81	\$ 150.00	AA	1.7
AE63R-30-11-81	\$ 1,208.00	AA	1.5	AF50M-30-11-70	\$ 953.00	AA	1.9	AL16-30-10-81	\$ 150.00	AA	1.7
AE75-22-00-86	\$ 570.00	AA	1.13	AF50R-30-11-70	\$ 1,050.00	AA	1.9	AL16-40-00-81	\$ 172.00	AA	1.13
AE75-30-11-81	\$ 518.00	AA	1.5	AF580-30-11-70	\$ 6,900.00	AEA	1.9	AL16M-30-01-81	\$ 441.00	AA	1.7
AE75-40-00-81	\$ 570.00	AA	1.13	AF580M-30-11-70	\$ 18,375.00	AEA	1.9	AL16M-30-10-81	\$ 441.00	AA	1.7
AE753000RT-81	\$ 501.00	AA	1.10	AF580R-30-11-70	\$ 18,390.00	AEA	1.9	AL16N0-30-10-81	\$ 150.00	AA	1.12
AE75M-30-11-81	\$ 1,365.00	AA	1.5	AF63-30-11-70	\$ 495.00	AA	1.9	AL16N0M-10-81	\$ 441.00	AA	1.12
AE75N3-30-11-81	\$ 518.00	AA	1.12	AF63M-30-11-70	\$ 1,116.00	AA	1.9	AL16N0R-10-81	\$ 501.00	AA	1.12
AE75N3M-11-81	\$ 1,365.00	AA	1.12	AF63R-30-11-70	\$ 1,259.00	AA	1.9	AL16R-30-01-81	\$ 501.00	AA	1.7
AE75N3R-11-81	\$ 1,493.00	AA	1.12	AF75-22-00-70	\$ 645.00	AA	1.14	AL16R-30-10-81	\$ 501.00	AA	1.7
AE75R-30-11-81	\$ 1,493.00	AA	1.5	AF75-30-11-70	\$ 535.00	AA	1.9	AL16Z-30-01-15	\$ 150.00	AA	1.7
AE9-30-11-81	\$ 118.00	AA	1.5	AF75-40-00-70	\$ 645.00	AA	1.14	AL16Z-30-10-15	\$ 150.00	AA	1.7
AE93000RT-81	\$ 91.00	AA	1.10	AF750-30-11-70	\$ 7,200.00	AEA	1.9	AL16ZM-30-01-15	\$ 441.00	AA	1.7
AE95-30-11-81	\$ 555.00	AA	1.5	AF750M-30-11-70	\$ 19,725.00	AEA	1.9	AL16ZM-30-10-15	\$ 441.00	AA	1.7
AE953000RT-81	\$ 571.00	AA	1.10	AF750N7-3011-70	\$ 7,200.00	AEA	1.11	AL16ZR-30-01-15	\$ 501.00	AA	1.7
AE95M-30-11-81	\$ 1,440.00	AA	1.5	AF750N7M-11-70	\$ 19,725.00	AEA	1.11	AL16ZR-30-10-15	\$ 501.00	AA	1.7
AE95R-30-11-81	\$ 1,635.00	AA	1.5	AF750N7R-11-70	\$ 19,740.00	AEA	1.11	AL230	\$ 224.00	CB8	14.42
AE9M-30-11-81	\$ 335.00	AA	1.5	AF750R-30-11-70	\$ 19,740.00	AEA	1.9	AL24	\$ 224.00	CB8	14.42
AE9N00-30-11-81	\$ 118.00	AA	1.12	AF75M-30-11-70	\$ 1,399.00	AA	1.9	AL26-22-00-81	\$ 224.00	AA	1.13
AE9N00M-11-81	\$ 335.00	AA	1.12	AF75R-30-11-70	\$ 1,542.00	AA	1.9	AL26-30-01-81	\$ 190.00	AA	1.7
AE9N00R-11-81	\$ 395.00	AA	1.12	AF95-30-11-70	\$ 570.00	AA	1.9	AL26-30-10-81	\$ 190.00	AA	1.7
AE9R-30-11-81	\$ 395.00	AA	1.5	AF95M-30-11-70	\$ 1,470.00	AA	1.9	AL26-40-00-81	\$ 224.00	AA	1.13
AF110-30-11-70	\$ 600.00	AA	1.9	AF95R-30-11-70	\$ 1,665.00	AA	1.9	AL26M-30-01-81	\$ 473.00	AA	1.7
AF110M-30-11-70	\$ 1,605.00	AA	1.9	AGS-AM240	\$ 3,843.00	J	18.2	AL26M-30-10-81	\$ 473.00	AA	1.7
AF110R-30-11-70	\$ 1,868.00	AA	1.9	AGS-AM48	\$ 3,843.00	J	18.2	AL26N1-30-10-81	\$ 190.00	AA	1.12
AF1350-30-11-70	\$ 8,490.00	AEA	1.9	AGS-CP5	\$ 84.00	J	18.2	AL26N1M-10-81	\$ 473.00	AA	1.12
AF145-30-11-70	\$ 1,110.00	AEA	1.9	AGS-CP1	\$ 92.00	J	18.2	AL26N1R-10-81	\$ 533.00	AA	1.12

AL26R-30-01-81 – BEF460V/OESA400

Catalog number	List price	Discount schedule	Page number	Catalog number	List price	Discount schedule	Page number	Catalog number	List price	Discount schedule	Page number
AL26R-30-01-81	\$ 533.00	AA	1.7	B6SS-**	\$ 108.00	AA	4.7	BC7FP-2.4	\$ 80.00	AA	4.4
AL26R-30-10-81	\$ 533.00	AA	1.7	B6SS-*01*	\$ 108.00	AA	4.7	BC7S-**	\$ 138.00	AA	4.6
AL30-30-01-81	\$ 260.00	AA	1.7	B7C-*	\$ 72.00	AA	4.2	BC7S-*01*	\$ 138.00	AA	4.6
AL30-30-10-81	\$ 260.00	AA	1.7	B7C*01	\$ 72.00	AA	4.2	BC7SP-01-1.4	\$ 80.00	AA	4.4
AL30M-30-01-81	\$ 618.00	AA	1.7	B7C4P-*	\$ 72.00	AA	4.2	BC7SP-01-2.4	\$ 80.00	AA	4.4
AL30M-30-10-81	\$ 618.00	AA	1.7	B7C4PFP-*	\$ 72.00	AA	4.2	BC7SP-1.4	\$ 80.00	AA	4.4
AL30R-30-01-81	\$ 678.00	AA	1.7	B7C4PSP-*	\$ 72.00	AA	4.2	BC7SP-2.4	\$ 80.00	AA	4.4
AL30R-30-10-81	\$ 678.00	AA	1.7	B7CFP-*	\$ 72.00	AA	4.2	BC7SR-**	\$ 231.00	AA	4.6
AL40-30-01-81	\$ 300.00	AA	1.7	B7CFP*01	\$ 72.00	AA	4.2	BC7SR-*01*	\$ 231.00	AA	4.6
AL40-30-10-81	\$ 300.00	AA	1.7	B7CSP-*	\$ 72.00	AA	4.2	BC7SS-**	\$ 138.00	AA	4.7
AL40M-30-01-81	\$ 715.00	AA	1.7	B7CSP*01	\$ 72.00	AA	4.2	BC7SS-*01*	\$ 138.00	AA	4.7
AL40M-30-10-81	\$ 715.00	AA	1.7	B7S-**	\$ 132.00	AA	4.6	BEA110/495	\$ 180.00	MA	5.17
AL40R-30-01-81	\$ 775.00	AA	1.7	B7S-*01*	\$ 132.00	AA	4.6	BEA16/116	\$ 13.50	MA	5.5
AL40R-30-10-81	\$ 775.00	AA	1.7	B7SC-01-1.7	\$ 69.00	AA	4.5	BEA16/325	\$ 13.50	MA	5.12
AL48	\$ 224.00	CB8	14.42	B7SC-01-2.8	\$ 69.00	AA	4.5	BEA185-20D/S34	\$ 50.00	AEA	1.116
AL500	\$ 224.00	CB8	14.42	B7SC-1.7	\$ 69.00	AA	4.5	BEA185/S3/S4	\$ 60.00	ABA	1.3
AL9-22-00-81	\$ 133.00	AA	1.13	B7SC-2.8	\$ 69.00	AA	4.5	BEA185/T3	\$ 60.00	ABA	1.3
AL9-30-01-81	\$ 110.00	AA	1.7	B7SR-**	\$ 218.00	AA	4.6	BEA185D/S3/S4	\$ 70.00	ABA	1.3
AL9-30-10-81	\$ 110.00	AA	1.7	B7SR-*01*	\$ 218.00	AA	4.6	BEA185H/S4	\$ 150.00	ABA	1.3
AL9-40-00-81	\$ 133.00	AA	1.13	B7SS-**	\$ 132.00	AA	4.7	BEA210-20D/S4	\$ 55.00	AEA	1.116
AL9M-30-01-81	\$ 319.00	AA	1.7	B7SS-*01*	\$ 132.00	AA	4.7	BEA210/S4	\$ 70.00	ABA	1.3
AL9M-30-10-81	\$ 319.00	AA	1.7	BA5-50	\$ 15.00	ABA	1.25	BEA210D/S4	\$ 80.00	ABA	1.3
AL9N00-30-10-81	\$ 110.00	AA	1.12	BA50	\$ 30.00	AA	4.11	BEA210H/S4	\$ 220.00	ABA	1.3
AL9N00M-10-81	\$ 319.00	AA	1.12	BC6-01-1.4	\$ 57.00	AA	4.4	BEA26/116	\$ 15.00	MA	5.5
AL9N00R-10-81	\$ 379.00	AA	1.12	BC6-01-2.4	\$ 63.00	AA	4.4	BEA26/325	\$ 15.00	MA	5.12
AL9R-30-01-81	\$ 379.00	AA	1.7	BC6-1.4	\$ 57.00	AA	4.4	BEA300-20D/S5	\$ 60.00	AEA	1.116
AL9R-30-10-81	\$ 379.00	AA	1.7	BC6-2.4	\$ 63.00	AA	4.4	BEA300/S5	\$ 75.00	ABA	1.3
AL9Z-30-01-15	\$ 110.00	AA	1.7	BC6C-*	\$ 57.00	AA	4.2	BEA300D/S5	\$ 85.00	ABA	1.3
AL9Z-30-10-15	\$ 110.00	AA	1.7	BC6C*01	\$ 57.00	AA	4.2	BEA300H/S5	\$ 220.00	ABA	1.3
AL9ZM-30-01-15	\$ 319.00	AA	1.7	BC6CFP-*	\$ 57.00	AA	4.2	BEA40/450	\$ 54.00	MA	5.17
AL9ZM-30-10-15	\$ 319.00	AA	1.7	BC6CFP*01	\$ 57.00	AA	4.2	BEA400/S5	\$ 95.00	ABA	1.3
AL9ZR-30-01-15	\$ 379.00	AA	1.7	BC6CSP-*	\$ 57.00	AA	4.2	BEA400D/S5	\$ 105.00	ABA	1.3
AL9ZR-30-10-15	\$ 379.00	AA	1.7	BC6CSP*01	\$ 57.00	AA	4.2	BEA400H/S5	\$ 435.00	ABA	1.3
ATK1350/4	\$ 235.00	ABA	1.25	BC6FP-01-1.4	\$ 57.00	AA	4.4	BEA460H/S6	\$ 660.00	ABA	1.3
ATK1650/4	\$ 335.00	ABA	1.25	BC6FP-01-2.4	\$ 63.00	AA	4.4	BEA50/450	\$ 63.00	MA	5.17
ATK1650/6	\$ 560.00	ABA	1.25	BC6FP-1.4	\$ 57.00	AA	4.4	BEA7/116	\$ 12.00	MA	5.5
ATK185	\$ 45.00	ABA	1.25	BC6FP-2.4	\$ 63.00	AA	4.4	BEA7/325	\$ 12.00	MA	5.12
ATK300	\$ 68.00	ABA	1.25	BC6S-**	\$ 114.00	AA	4.6	BEA75/495	\$ 120.00	MA	5.17
ATK300/2	\$ 110.00	ABA	1.25	BC6S-*01*	\$ 114.00	AA	4.6	BEA750/S6	\$ 115.00	ABA	1.3
ATK300/2HK	\$ 120.00	ABA	2.7	BC6SP-01-1.4	\$ 57.00	AA	4.4	BEA750D/S6	\$ 125.00	ABA	1.3
ATK300HK	\$ 78.00	ABA	2.7	BC6SP-01-2.4	\$ 63.00	AA	4.4	BEA750H/S6	\$ 670.00	ABA	1.3
ATK580/2	\$ 150.00	ABA	1.25	BC6SP-1.4	\$ 57.00	AA	4.4	BED110U	\$ 225.00	ABA	1.28
ATK750/3	\$ 225.00	ABA	1.25	BC6SP-2.4	\$ 63.00	AA	4.4	BED145U	\$ 250.00	ABA	1.28
B6C-*	\$ 51.00	AA	4.2	BC6SR-**	\$ 180.00	AA	4.6	BED185U	\$ 290.00	ABA	1.28
B6C-*01	\$ 51.00	AA	4.2	BC6SR*01*	\$ 180.00	AA	4.6	BED210U	\$ 375.00	ABA	1.28
B6C4P-*	\$ 51.00	AA	4.2	BC6SS-**	\$ 114.00	AA	4.7	BED300U	\$ 500.00	ABA	1.28
B6C4PFP-*	\$ 51.00	AA	4.2	BC6SS*01*	\$ 114.00	AA	4.7	BED400U	\$ 850.00	ABA	1.28
B6C4PSP-*	\$ 51.00	AA	4.2	BC7-01-1.4	\$ 80.00	AA	4.4	BED40U	\$ 53.00	ABA	1.28
B6CFP-*	\$ 51.00	AA	4.2	BC7-01-2.4	\$ 80.00	AA	4.4	BED460U	\$ 900.00	ABA	1.28
B6CFP*01	\$ 51.00	AA	4.2	BC7-1.4	\$ 80.00	AA	4.4	BED50U	\$ 165.00	ABA	1.28
B6CSP-*	\$ 51.00	AA	4.2	BC7-2.4	\$ 80.00	AA	4.4	BED580U	\$ 1,250.00	ABA	1.28
B6CSP*01	\$ 51.00	AA	4.2	BC7C-*	\$ 78.00	AA	4.2	BED750U	\$ 1,450.00	ABA	1.28
B6S-**	\$ 108.00	AA	4.6	BC7C*01	\$ 78.00	AA	4.2	BED75U	\$ 180.00	ABA	1.28
B6S-*01*	\$ 108.00	AA	4.6	BC7CFP-*	\$ 78.00	AA	4.2	BED95U	\$ 195.00	ABA	1.28
B6SC-01-1.7	\$ 65.00	AA	4.5	BC7CFP*01	\$ 78.00	AA	4.2	BEF185H/OESA250	\$ 515.00	ABA	1.30
B6SC-01-2.8	\$ 65.00	AA	4.5	BC7CSP-*	\$ 78.00	AA	4.2	BEF185V/OESA250	\$ 260.00	ABA	1.30
B6SC-1.7	\$ 65.00	AA	4.5	BC7CSP*01	\$ 78.00	AA	4.2	BEF300H/OESA400	\$ 595.00	ABA	1.30
B6SC-2.8	\$ 65.00	AA	4.5	BC7FP-01-1.4	\$ 80.00	AA	4.4	BEF300V/OESA400	\$ 270.00	ABA	1.30
B6SR-**	\$ 179.00	AA	4.6	BC7FP-01-2.4	\$ 80.00	AA	4.4	BEF460H/OESA400	\$ 615.00	ABA	1.30
B6SR*01*	\$ 179.00	AA	4.6	BC7FP-1.4	\$ 80.00	AA	4.4	BEF460V/OESA400	\$ 300.00	ABA	1.30

BEF750V/OESA800 – C25D12.5-3FI

Alphanumeric

0

Catalog number	List price	Discount schedule	Page number	Catalog number	List price	Discount schedule	Page number	Catalog number	List price	Discount schedule	Page number
BEF750V/OESA800	\$ 320.00	ABA	1.30	C21G10	\$ 257.00	F1	19.16	C24G17	\$ 407.00	F1	19.9
BEM110-30	\$ 180.00	ABA	1.28	C21G10SC	\$ 270.00	F1	19.17	C24G2	\$ 145.00	F1	19.9
BEM16-30	\$ 23.00	ABA	1.28	C21G1SC	\$ 131.00	F1	19.17	C24G2-3FI	\$ 225.00	F1	19.12
BEM185-30	\$ 260.00	ABA	1.28	C21G2	\$ 129.00	F1	19.16	C24G2.5	\$ 161.00	F1	19.9
BEM26-30	\$ 30.00	ABA	1.28	C21G2.5	\$ 145.00	F1	19.16	C24G2.5-3FI	\$ 231.00	F1	19.12
BEM40-30	\$ 45.00	ABA	1.28	C21G2.5SC	\$ 158.00	F1	19.17	C24G20	\$ 450.00	F1	19.9
BEM460-30	\$ 850.00	ABA	1.28	C21G2SC	\$ 152.00	F1	19.17	C24G3	\$ 168.00	F1	19.9
BEM75-30	\$ 165.00	ABA	1.28	C21G3.5	\$ 161.00	F1	19.16	C24G3-3FI	\$ 236.00	F1	19.12
BEM750-30	\$ 1,200.00	ABA	1.28	C21G3.5SC	\$ 174.00	F1	19.17	C24G3.5	\$ 177.00	F1	19.9
BEMA300-30	\$ 470.00	ABA	1.28	C21G5	\$ 172.00	F1	19.16	C24G3.5-3FI	\$ 247.00	F1	19.12
BES110-30	\$ 90.00	ABA	1.28	C21G5SC	\$ 185.00	F1	19.17	C24G4	\$ 193.00	F1	19.9
BES185-30	\$ 130.00	ABA	1.28	C21G7.5	\$ 220.00	F1	19.16	C24G4-3FI	\$ 268.00	F1	19.12
BES460-30	\$ 425.00	ABA	1.28	C21G7.5SC	\$ 233.00	F1	19.17	C24G5	\$ 204.00	F1	19.9
BES75-30	\$ 75.00	ABA	1.28	C23W9V2	\$ 19.80	RA	10.132	C24G5-3FI	\$ 289.00	F1	19.12
BES750-30	\$ 650.00	ABA	1.28	C23W9V6	\$ 29.10	RA	10.132	C24G6	\$ 225.00	F1	19.9
BESA300-30	\$ 200.00	ABA	1.28	C23WSV2	\$ 19.80	RA	10.129	C24G6-3FI	\$ 300.00	F1	19.12
BEXT-75	\$ 15.00	ABA	1.29	C23WSV6	\$ 29.10	RA	10.129	C24G7	\$ 257.00	F1	19.9
BIT-PZ1	\$ 4.00	CB8	14.20	C24D1	\$ 145.00	F1	19.9	C24G7-3FI	\$ 321.00	F1	19.12
BIT-PZ2	\$ 4.00	CB8	14.20	C24D1-3FI	\$ 215.00	F1	19.12	C24G7.5	\$ 263.00	F1	19.9
BN6	\$ 15.00	AA	4.11	C24D1.5	\$ 151.00	F1	19.9	C24G7.5-3FI	\$ 332.00	F1	19.12
BP-12P	\$ 7.00	CB8	14.19	C24D1.5-3FI	\$ 231.00	F1	19.12	C24G8	\$ 268.00	F1	19.9
BP-1P	\$ 6.00	CB8	14.19	C24D10	\$ 300.00	F1	19.9	C24G8-3FI	\$ 354.00	F1	19.12
BSM6-30	\$ 12.00	AA	4.12	C24D11	\$ 316.00	F1	19.9	C24G9	\$ 279.00	F1	19.9
C11G0.8	\$ 124.00	F1	19.16	C24D12	\$ 343.00	F1	19.9	C24R1	\$ 145.00	F1	19.9
C11G0.8SC	\$ 136.00	F1	19.17	C24D12.5	\$ 354.00	F1	19.9	C24R1-3FI	\$ 215.00	F1	19.12
C11G1.1	\$ 129.00	F1	19.16	C24D14	\$ 365.00	F1	19.9	C24R1.5	\$ 151.00	F1	19.9
C11G1.1SC	\$ 142.00	F1	19.17	C24D15	\$ 386.00	F1	19.9	C24R1.5-3FI	\$ 231.00	F1	19.12
C11G2	\$ 150.00	F1	19.16	C24D17	\$ 418.00	F1	19.9	C24R10	\$ 300.00	F1	19.9
C11G2.5	\$ 161.00	F1	19.16	C24D2	\$ 156.00	F1	19.9	C24R11	\$ 316.00	F1	19.9
C11G2.5SC	\$ 163.00	F1	19.17	C24D2-3FI	\$ 236.00	F1	19.12	C24R12	\$ 343.00	F1	19.9
C11G2SC	\$ 152.00	F1	19.17	C24D2.5	\$ 172.00	F1	19.9	C24R12.5	\$ 354.00	F1	19.9
C11G3	\$ 177.00	F1	19.16	C24D2.5-3FI	\$ 242.00	F1	19.12	C24R14	\$ 365.00	F1	19.9
C11G3SC	\$ 179.00	F1	19.17	C24D20	\$ 461.00	F1	19.9	C24R15	\$ 386.00	F1	19.9
C11G4	\$ 198.00	F1	19.16	C24D3	\$ 179.00	F1	19.9	C24R17	\$ 418.00	F1	19.9
C11G4SC	\$ 211.00	F1	19.17	C24D3-3FI	\$ 247.00	F1	19.12	C24R2	\$ 156.00	F1	19.9
C11G5	\$ 241.00	F1	19.16	C24D3.5	\$ 188.00	F1	19.9	C24R2-3FI	\$ 236.00	F1	19.12
C11G5SC	\$ 254.00	F1	19.17	C24D3.5-3FI	\$ 258.00	F1	19.12	C24R2.5	\$ 172.00	F1	19.9
C11G7.5	\$ 273.00	F1	19.16	C24D4	\$ 204.00	F1	19.9	C24R2.5-3FI	\$ 242.00	F1	19.12
C11G7.5SC	\$ 286.00	F1	19.17	C24D4-3FI	\$ 279.00	F1	19.12	C24R20	\$ 461.00	F1	19.9
C13W92	\$ 14.40	RA	10.122	C24D5	\$ 215.00	F1	19.9	C24R3	\$ 179.00	F1	19.9
C13W9LNV2	\$ 25.90	RA	10.123	C24D5-3FI	\$ 300.00	F1	19.12	C24R3-3FI	\$ 247.00	F1	19.12
C13W9LPV2	\$ 25.90	RA	10.123	C24D6	\$ 236.00	F1	19.9	C24R3.5	\$ 188.00	F1	19.9
C13W9V2	\$ 14.40	RA	10.122	C24D6-3FI	\$ 311.00	F1	19.12	C24R3.5FI	\$ 258.00	F1	19.12
C13W9V4	\$ 17.40	RA	10.122	C24D7	\$ 268.00	F1	19.9	C24R4	\$ 204.00	F1	19.9
C13WSV2	\$ 14.40	RA	10.121	C24D7-3FI	\$ 332.00	F1	19.12	C24R4-3FI	\$ 279.00	F1	19.12
C13WSV4	\$ 17.40	RA	10.121	C24D7.5	\$ 274.00	F1	19.9	C24R5	\$ 215.00	F1	19.9
C14W9V2	\$ 16.60	RA	10.125	C24D7.5-3FI	\$ 343.00	F1	19.12	C24R5-3FI	\$ 300.00	F1	19.12
C14W9V4	\$ 20.30	RA	10.125	C24D8	\$ 279.00	F1	19.9	C24R6	\$ 236.00	F1	19.9
C14WSV2	\$ 16.60	RA	10.124	C24D8-3FI	\$ 365.00	F1	19.12	C24R6-3FI	\$ 311.00	F1	19.12
C14WSV4	\$ 20.30	RA	10.124	C24D9	\$ 290.00	F1	19.9	C24R7	\$ 268.00	F1	19.9
C15W9V2	\$ 17.70	RA	10.127	C24G1	\$ 134.00	F1	19.9	C24R7-3FI	\$ 332.00	F1	19.12
C15W9V4	\$ 20.50	RA	10.127	C24G1-3FI	\$ 204.00	F1	19.12	C24R7.5	\$ 274.00	F1	19.9
C15WNV4	\$ 22.50	RA	10.127	C24G1.5	\$ 140.00	F1	19.9	C24R7.5-3FI	\$ 343.00	F1	19.12
C15WSV2	\$ 17.70	RA	10.126	C24G1.5-3FI	\$ 220.00	F1	19.12	C24R8	\$ 279.00	F1	19.9
C15WSV4	\$ 22.50	RA	10.126	C24G10	\$ 289.00	F1	19.9	C24R8-3FI	\$ 365.00	F1	19.12
C1XW9	\$ 23.70	RA	10.128	C24G11	\$ 305.00	F1	19.9	C24R9	\$ 290.00	F1	19.9
C1XWS	\$ 23.70	RA	10.128	C24G12	\$ 332.00	F1	19.9	C25D10-3FI	\$ 407.00	F1	19.12
C21G1	\$ 118.00	F1	19.16	C24G12.5	\$ 343.00	F1	19.9	C25D11-3FI	\$ 429.00	F1	19.12
C21G1.5	\$ 124.00	F1	19.16	C24G14	\$ 354.00	F1	19.9	C25D12-3FI	\$ 461.00	F1	19.12
C21G1.5SC	\$ 147.00	F1	19.17	C24G15	\$ 375.00	F1	19.9	C25D12.5-3FI	\$ 482.00	F1	19.12

C25D14-3FI – C44D5

Catalog number	List price	Discount schedule	Page number	Catalog number	List price	Discount schedule	Page number	Catalog number	List price	Discount schedule	Page number
C25D14-3FI	\$ 504.00	F1	19.12	C26D70	\$ 1,247.00	F2	19.9	C41G15SC	\$ 227.00	F1	19.17
C25D15-3FI	\$ 514.00	F1	19.12	C26D80	\$ 1,376.00	F2	19.9	C41G17	\$ 225.00	F1	19.16
C25D17-3FI	\$ 568.00	F1	19.12	C26G45	\$ 814.00	F1	19.9	C41G17SC	\$ 238.00	F1	19.17
C25D20-3FI	\$ 600.00	F1	19.12	C26G45-3FI	\$ 1,124.00	F1	19.12	C41G2	\$ 134.00	F1	19.16
C25D22.5	\$ 482.00	F1	19.9	C26G50	\$ 889.00	F1	19.9	C41G2.5	\$ 140.00	F1	19.16
C25D22.5-3FI	\$ 653.00	F1	19.12	C26G50-3FI	\$ 1,231.00	F1	19.12	C41G2.5SC	\$ 152.00	F1	19.17
C25D25	\$ 514.00	F1	19.9	C26G55	\$ 1,124.00	F1	19.9	C41G2SC	\$ 147.00	F1	19.17
C25D25-3FI	\$ 707.00	F1	19.12	C26G55-3FI	\$ 1,311.00	F1	19.12	C41G3.5	\$ 156.00	F1	19.16
C25D30	\$ 568.00	F1	19.9	C26G60	\$ 1,177.00	F1	19.9	C41G3.5SC	\$ 168.00	F1	19.17
C25D30-3FI	\$ 814.00	F1	19.12	C26G60-3FI	\$ 1,418.00	F1	19.12	C41G4	\$ 158.00	F1	19.16
C25D35	\$ 621.00	F1	19.9	C26G70	\$ 1,236.00	F2	19.9	C41G4SC	\$ 171.00	F1	19.17
C25D35-3FI	\$ 894.00	F1	19.12	C26G80	\$ 1,365.00	F2	19.9	C41G5	\$ 166.00	F1	19.16
C25D40	\$ 707.00	F1	19.9	C26R45	\$ 825.00	F1	19.9	C41G5SC	\$ 179.00	F1	19.17
C25D40-3FI	\$ 1,028.00	F1	19.12	C26R45-3FI	\$ 1,135.00	F1	19.12	C41G6	\$ 172.00	F1	19.16
C25D9-3FI	\$ 386.00	F1	19.12	C26R50	\$ 900.00	F1	19.9	C41G6SC	\$ 185.00	F1	19.17
C25G10-3FI	\$ 396.00	F1	19.12	C26R50-3FI	\$ 1,242.00	F1	19.12	C41G7.5	\$ 177.00	F1	19.16
C25G11-3FI	\$ 418.00	F1	19.12	C26R55	\$ 1,135.00	F1	19.9	C41G7.5SC	\$ 190.00	F1	19.17
C25G12-3FI	\$ 450.00	F1	19.12	C26R55-3FI	\$ 1,322.00	F1	19.12	C41G8	\$ 182.00	F1	19.16
C25G12.5-3FI	\$ 471.00	F1	19.12	C26R60	\$ 1,188.00	F1	19.9	C41G8SC	\$ 195.00	F1	19.17
C25G14-3FI	\$ 493.00	F1	19.12	C26R60-3FI	\$ 1,429.00	F1	19.12	C41G9	\$ 188.00	F1	19.16
C25G15-3FI	\$ 503.00	F1	19.12	C26R70	\$ 1,247.00	F2	19.9	C41G9SC	\$ 201.00	F1	19.17
C25G17-3FI	\$ 557.00	F1	19.12	C26R80	\$ 1,376.00	F2	19.9	C44D1.5	\$ 145.00	F1	19.10
C25G20-3FI	\$ 589.00	F1	19.12	C2SS110*-01	\$ 22.70	CA	8.3	C44D1.5-3FI	\$ 215.00	F1	19.13
C25G22.5	\$ 471.00	F1	19.9	C2SS110*-02	\$ 27.20	CA	8.3	C44D10	\$ 225.00	F1	19.10
C25G22.5-3FI	\$ 642.00	F1	19.12	C2SS110*-10	\$ 19.60	CA	8.3	C44D10-3FI	\$ 306.00	F1	19.13
C25G25	\$ 503.00	F1	19.9	C2SS110*-11	\$ 27.20	CA	8.3	C44D12	\$ 236.00	F1	19.10
C25G25-3FI	\$ 696.00	F1	19.12	C2SS110*-20	\$ 27.20	CA	8.3	C44D12-3FI	\$ 311.00	F1	19.13
C25G30	\$ 557.00	F1	19.9	C2SS210*-01	\$ 22.70	CA	8.3	C44D12.5	\$ 242.00	F1	19.10
C25G30-3FI	\$ 803.00	F1	19.12	C2SS210*-02	\$ 27.20	CA	8.3	C44D12.5-3FI	\$ 316.00	F1	19.13
C25G35	\$ 610.00	F1	19.9	C2SS210*-10	\$ 16.70	CA	8.3	C44D13	\$ 252.00	F1	19.10
C25G35-3FI	\$ 883.00	F1	19.12	C2SS210*-11	\$ 27.20	CA	8.3	C44D13-3FI	\$ 322.00	F1	19.13
C25G40	\$ 696.00	F1	19.9	C2SS210*-20	\$ 27.20	CA	8.3	C44D13.5	\$ 258.00	F1	19.10
C25G9-3FI	\$ 375.00	F1	19.12	C2SS310*-01	\$ 22.70	CA	8.3	C44D13.5-3FI	\$ 324.00	F1	19.13
C25R10-3FI	\$ 407.00	F1	19.12	C2SS310*-02	\$ 27.20	CA	8.3	C44D14	\$ 263.00	F1	19.10
C25R11-3FI	\$ 429.00	F1	19.12	C2SS310*-10	\$ 22.70	CA	8.3	C44D14-3FI	\$ 327.00	F1	19.13
C25R12-3FI	\$ 461.00	F1	19.12	C2SS310*-11	\$ 27.20	CA	8.3	C44D15	\$ 268.00	F1	19.10
C25R12.5-3FI	\$ 482.00	F1	19.12	C2SS310*-20	\$ 27.20	CA	8.3	C44D15-3FI	\$ 338.00	F1	19.13
C25R14-3FI	\$ 504.00	F1	19.12	C35-10D0.1	\$ 38.00	ABA	1.16	C44D16	\$ 274.00	F1	19.10
C25R15-3FI	\$ 514.00	F1	19.12	C35F40-3FI	\$ 1,017.00	F1	19.12	C44D16-3FI	\$ 343.00	F1	19.13
C25R17-3FI	\$ 568.00	F1	19.12	C3SS110*-02	\$ 27.20	CA	8.3	C44D17	\$ 279.00	F1	19.10
C25R20-3FI	\$ 600.00	F1	19.12	C3SS110*-11	\$ 27.20	CA	8.3	C44D17.5	\$ 284.00	F1	19.10
C25R22.5	\$ 482.00	F1	19.9	C3SS110*-20	\$ 27.20	CA	8.3	C44D18	\$ 290.00	F1	19.10
C25R22.5-3FI	\$ 653.00	F1	19.12	C3SS210*-02	\$ 27.20	CA	8.3	C44D19	\$ 295.00	F1	19.10
C25R25	\$ 514.00	F1	19.9	C3SS210*-11	\$ 27.20	CA	8.3	C44D2	\$ 151.00	F1	19.10
C25R25-3FI	\$ 707.00	F1	19.12	C3SS210*-20	\$ 27.20	CA	8.3	C44D2-3FI	\$ 222.00	F1	19.13
C25R30	\$ 568.00	F1	19.9	C3SS310*-02	\$ 27.20	CA	8.3	C44D2.5	\$ 156.00	F1	19.10
C25R30-3FI	\$ 814.00	F1	19.12	C3SS310*-11	\$ 27.20	CA	8.3	C44D2.5-3FI	\$ 225.00	F1	19.13
C25R35	\$ 621.00	F1	19.9	C3SS310*-20	\$ 27.20	CA	8.3	C44D20	\$ 306.00	F1	19.10
C25R35-3FI	\$ 894.00	F1	19.12	C3SS710*-02	\$ 27.20	CA	8.3	C44D21	\$ 322.00	F1	19.10
C25R40	\$ 707.00	F1	19.9	C3SS710*-11	\$ 27.20	CA	8.3	C44D22	\$ 327.00	F1	19.10
C25R40-3FI	\$ 1,028.00	F1	19.12	C3SS710*-20	\$ 27.20	CA	8.3	C44D22.5	\$ 332.00	F1	19.10
C25R9-3FI	\$ 386.00	F1	19.12	C41G0.9	\$ 118.00	F1	19.16	C44D24	\$ 343.00	F1	19.10
C26D45	\$ 825.00	F1	19.9	C41G0.9SC	\$ 131.00	F1	19.17	C44D25	\$ 349.00	F1	19.10
C26D45-3FI	\$ 1,135.00	F1	19.12	C41G1.5	\$ 129.00	F1	19.16	C44D27	\$ 365.00	F1	19.10
C26D50	\$ 900.00	F1	19.9	C41G1.5SC	\$ 142.00	F1	19.17	C44D3	\$ 161.00	F1	19.10
C26D50-3FI	\$ 1,242.00	F1	19.12	C41G10	\$ 193.00	F1	19.16	C44D3-3FI	\$ 228.00	F1	19.13
C26D55	\$ 1,135.00	F1	19.9	C41G10SC	\$ 206.00	F1	19.17	C44D30	\$ 381.00	F1	19.10
C26D55-3FI	\$ 1,322.00	F1	19.12	C41G14	\$ 204.00	F1	19.16	C44D4	\$ 163.00	F1	19.10
C26D60	\$ 1,188.00	F1	19.9	C41G14SC	\$ 217.00	F1	19.17	C44D4-3FI	\$ 231.00	F1	19.13
C26D60-3FI	\$ 1,429.00	F1	19.12	C41G15	\$ 214.00	F1	19.16	C44D5	\$ 172.00	F1	19.10

C44D5-3FI – C45R40

Alphanumeric

0

Catalog number	List price	Discount schedule	Page number	Catalog number	List price	Discount schedule	Page number	Catalog number	List price	Discount schedule	Page number
C44D5-3FI	\$ 233.00	F1	19.13	C44R10-3FI	\$ 306.00	F1	19.13	C45D35-3FI	\$ 546.00	F1	19.13
C44D6	\$ 183.00	F1	19.10	C44R12	\$ 236.00	F1	19.10	C45D37.5	\$ 439.00	F1	19.10
C44D6-3FI	\$ 242.00	F1	19.13	C44R12-3FI	\$ 311.00	F1	19.13	C45D37.5-3FI	\$ 557.00	F1	19.13
C44D7.5	\$ 199.00	F1	19.10	C44R12.5	\$ 242.00	F1	19.10	C45D40	\$ 456.00	F1	19.10
C44D7.5-3FI	\$ 268.00	F1	19.13	C44R12.5-3FI	\$ 316.00	F1	19.13	C45D40-3FI	\$ 568.00	F1	19.13
C44D8	\$ 204.00	F1	19.10	C44R13	\$ 252.00	F1	19.10	C45D42.5	\$ 472.00	F1	19.10
C44D8-3FI	\$ 284.00	F1	19.13	C44R13-3FI	\$ 322.00	F1	19.13	C45D42.5-3FI	\$ 600.00	F1	19.13
C44D9	\$ 215.00	F1	19.10	C44R13.5	\$ 258.00	F1	19.10	C45D45	\$ 588.00	F1	19.10
C44D9-3FI	\$ 295.00	F1	19.13	C44R13.5-3FI	\$ 324.00	F1	19.13	C45D45-3FI	\$ 632.00	F1	19.13
C44G1.5	\$ 134.00	F1	19.10	C44R14	\$ 263.00	F1	19.10	C45D47.5	\$ 498.00	F1	19.10
C44G1.5-3FI	\$ 204.00	F1	19.13	C44R14-3FI	\$ 327.00	F1	19.13	C45D47.5-3FI	\$ 653.00	F1	19.13
C44G10	\$ 214.00	F1	19.10	C44R15	\$ 268.00	F1	19.10	C45D50	\$ 504.00	F1	19.10
C44G10-3FI	\$ 295.00	F1	19.13	C44R15-3FI	\$ 338.00	F1	19.13	C45D50-3FI	\$ 675.00	F1	19.13
C44G12	\$ 225.00	F1	19.10	C44R16	\$ 274.00	F1	19.10	C45G17-3FI	\$ 343.00	F1	19.13
C44G12-3FI	\$ 300.00	F1	19.13	C44R16-3FI	\$ 343.00	F1	19.13	C45G17.5-3FI	\$ 354.00	F1	19.13
C44G12.5	\$ 231.00	F1	19.10	C44R17	\$ 279.00	F1	19.10	C45G18-3FI	\$ 364.00	F1	19.13
C44G12.5-3FI	\$ 305.00	F1	19.13	C44R17.5	\$ 284.00	F1	19.10	C45G19-3FI	\$ 375.00	F1	19.13
C44G13	\$ 241.00	F1	19.10	C44R18	\$ 290.00	F1	19.10	C45G20-3FI	\$ 386.00	F1	19.13
C44G13-3FI	\$ 311.00	F1	19.13	C44R19	\$ 295.00	F1	19.10	C45G21-3FI	\$ 391.00	F1	19.13
C44G13.5	\$ 247.00	F1	19.10	C44R2	\$ 151.00	F1	19.10	C45G22-3FI	\$ 396.00	F1	19.13
C44G13.5-3FI	\$ 313.00	F1	19.13	C44R2-3FI	\$ 222.00	F1	19.13	C45G22.5-3FI	\$ 407.00	F1	19.13
C44G14	\$ 252.00	F1	19.10	C44R2.4	\$ 156.00	F1	19.10	C45G24-3FI	\$ 418.00	F1	19.13
C44G14-3FI	\$ 316.00	F1	19.13	C44R2.5-3FI	\$ 225.00	F1	19.13	C45G25-3FI	\$ 428.00	F1	19.13
C44G15	\$ 257.00	F1	19.10	C44R20	\$ 306.00	F1	19.10	C45G27-3FI	\$ 450.00	F1	19.13
C44G15-3FI	\$ 327.00	F1	19.13	C44R21	\$ 322.00	F1	19.10	C45G30-3FI	\$ 482.00	F1	19.13
C44G16	\$ 263.00	F1	19.10	C44R22	\$ 327.00	F1	19.10	C45G32.5	\$ 386.00	F1	19.10
C44G16-3FI	\$ 332.00	F1	19.13	C44R22.5	\$ 332.00	F1	19.10	C45G32.5-3FI	\$ 509.00	F1	19.13
C44G17	\$ 268.00	F1	19.10	C44R24	\$ 343.00	F1	19.10	C45G35	\$ 412.00	F1	19.10
C44G17.5	\$ 273.00	F1	19.10	C44R25	\$ 349.00	F1	19.10	C45G35-3FI	\$ 535.00	F1	19.13
C44G18	\$ 279.00	F1	19.10	C44R27	\$ 365.00	F1	19.10	C45G37.5	\$ 428.00	F1	19.10
C44G19	\$ 284.00	F1	19.10	C44R3	\$ 161.00	F1	19.10	C45G37.5-3FI	\$ 546.00	F1	19.13
C44G2	\$ 140.00	F1	19.10	C44R3-3FI	\$ 228.00	F1	19.13	C45G40	\$ 445.00	F1	19.10
C44G2-3FI	\$ 211.00	F1	19.13	C44R30	\$ 381.00	F1	19.10	C45G40-3FI	\$ 557.00	F1	19.13
C44G2.5	\$ 145.00	F1	19.10	C44R4	\$ 163.00	F1	19.10	C45G42.5	\$ 461.00	F1	19.10
C44G2.5-3FI	\$ 214.00	F1	19.13	C44R4-3FI	\$ 231.00	F1	19.13	C45G42.5-3FI	\$ 589.00	F1	19.13
C44G20	\$ 295.00	F1	19.10	C44R5	\$ 172.00	F1	19.10	C45G45	\$ 477.00	F1	19.10
C44G21	\$ 311.00	F1	19.10	C44R5-3FI	\$ 233.00	F1	19.13	C45G45-3FI	\$ 621.00	F1	19.13
C44G22	\$ 316.00	F1	19.10	C44R6	\$ 183.00	F1	19.10	C45G47-3FI	\$ 642.00	F1	19.13
C44G22.5	\$ 321.00	F1	19.10	C44R6-3FI	\$ 242.00	F1	19.13	C45G47.5	\$ 487.00	F1	19.10
C44G24	\$ 332.00	F1	19.10	C44R7.5	\$ 199.00	F1	19.10	C45G50	\$ 493.00	F1	19.10
C44G25	\$ 338.00	F1	19.10	C44R7.5-3FI	\$ 268.00	F1	19.13	C45G50-3FI	\$ 664.00	F1	19.13
C44G27	\$ 354.00	F1	19.10	C44R8	\$ 204.00	F1	19.10	C45R17-3FI	\$ 354.00	F1	19.13
C44G3	\$ 150.00	F1	19.10	C44R8-3FI	\$ 284.00	F1	19.13	C45R17.5-3FI	\$ 365.00	F1	19.13
C44G3-3FI	\$ 217.00	F1	19.13	C44R9	\$ 215.00	F1	19.10	C45R18-3FI	\$ 375.00	F1	19.13
C44G30	\$ 370.00	F1	19.10	C44R9-3FI	\$ 295.00	F1	19.13	C45R19-3FI	\$ 386.00	F1	19.13
C44G4	\$ 152.00	F1	19.10	C45D17-3FI	\$ 354.00	F1	19.13	C45R20-3FI	\$ 397.00	F1	19.13
C44G4-3FI	\$ 220.00	F1	19.13	C45D17.5-3FI	\$ 365.00	F1	19.13	C45R21-3FI	\$ 402.00	F1	19.13
C44G5	\$ 161.00	F1	19.10	C45D18-3FI	\$ 375.00	F1	19.13	C45R22-3FI	\$ 407.00	F1	19.13
C44G5-3FI	\$ 222.00	F1	19.13	C45D19-3FI	\$ 386.00	F1	19.13	C45R22.5-3FI	\$ 418.00	F1	19.13
C44G6	\$ 172.00	F1	19.10	C45D20-3FI	\$ 397.00	F1	19.13	C45R24-3FI	\$ 429.00	F1	19.13
C44G6-3FI	\$ 231.00	F1	19.13	C45D21-3FI	\$ 402.00	F1	19.13	C45R25-3FI	\$ 439.00	F1	19.13
C44G7.5	\$ 188.00	F1	19.10	C45D22-3FI	\$ 407.00	F1	19.13	C45R27-3FI	\$ 461.00	F1	19.13
C44G7.5-3FI	\$ 257.00	F1	19.13	C45D22.5-3FI	\$ 418.00	F1	19.13	C45R30-3FI	\$ 493.00	F1	19.13
C44G8	\$ 193.00	F1	19.10	C45D24-3FI	\$ 429.00	F1	19.13	C45R32.5	\$ 397.00	F1	19.10
C44G8-3FI	\$ 273.00	F1	19.13	C45D25-3FI	\$ 439.00	F1	19.13	C45R32.5-3FI	\$ 520.00	F1	19.13
C44G9	\$ 204.00	F1	19.10	C45D27-3FI	\$ 461.00	F1	19.13	C45R35	\$ 423.00	F1	19.10
C44G9-3FI	\$ 284.00	F1	19.13	C45D30-3FI	\$ 493.00	F1	19.13	C45R35-3FI	\$ 546.00	F1	19.13
C44R1.5	\$ 145.00	F1	19.10	C45D32.5	\$ 397.00	F1	19.10	C45R37.5	\$ 439.00	F1	19.10
C44R1.5-3FI	\$ 215.00	F1	19.13	C45D32.5-3FI	\$ 520.00	F1	19.13	C45R37.5-3FI	\$ 557.00	F1	19.13
C44R10	\$ 225.00	F1	19.10	C45D35	\$ 423.00	F1	19.10	C45R40	\$ 456.00	F1	19.10

C45R40-3FI – C64G7.5-3FI

Catalog number	List price	Discount schedule	Page number	Catalog number	List price	Discount schedule	Page number	Catalog number	List price	Discount schedule	Page number
C45R40-3FI	\$ 568.00	F1	19.13	C46R75-3FI	\$ 825.00	F1	19.13	C48R90-3FI	\$ 974.00	F1	19.13
C45R42.5	\$ 472.00	F1	19.10	C46R77.5	\$ 739.00	F1	19.10	C48R95	\$ 916.00	F1	19.10
C45R42.5-3FI	\$ 600.00	F1	19.13	C46R77.5-3FI	\$ 841.00	F1	19.13	C48R95-3FI	\$ 1,012.00	F1	19.13
C45R45	\$ 588.00	F1	19.10	C48D100	\$ 932.00	F1	19.10	C61G10	\$ 193.00	F1	19.16
C45R45-3FI	\$ 632.00	F1	19.13	C48D100-3FI	\$ 1,044.00	F1	19.13	C61G10SC	\$ 206.00	F1	19.17
C45R47.5	\$ 498.00	F1	19.10	C48D105	\$ 974.00	F2	19.10	C61G15	\$ 220.00	F1	19.16
C45R47.5-3FI	\$ 653.00	F1	19.13	C48D105-3FI	\$ 1,291.00	F2	19.13	C61G15SC	\$ 233.00	F1	19.17
C45R50	\$ 504.00	F1	19.10	C48D110	\$ 1,023.00	F2	19.10	C61G2	\$ 145.00	F1	19.16
C45R50-3FI	\$ 675.00	F1	19.13	C48D110-3FI	\$ 1,321.00	F2	19.13	C61G2SC	\$ 147.00	F1	19.17
C46D52.5	\$ 525.00	F1	19.10	C48D115	\$ 1,044.00	F2	19.10	C61G3	\$ 150.00	F1	19.16
C46D52.5-3FI	\$ 696.00	F1	19.13	C48D115-3FI	\$ 1,361.00	F2	19.13	C61G3SC	\$ 163.00	F1	19.17
C46D55	\$ 541.00	F1	19.10	C48D120	\$ 1,065.00	F2	19.10	C61G4	\$ 156.00	F1	19.16
C46D55-3FI	\$ 718.00	F1	19.13	C48D120-3FI	\$ 1,401.00	F2	19.13	C61G4SC	\$ 168.00	F1	19.17
C46D57.5	\$ 563.00	F1	19.10	C48D80	\$ 760.00	F1	19.10	C61G5	\$ 166.00	F1	19.16
C46D57.5-3FI	\$ 739.00	F1	19.13	C48D80-3FI	\$ 867.00	F1	19.13	C61G5SC	\$ 179.00	F1	19.17
C46D60	\$ 573.00	F1	19.10	C48D85	\$ 803.00	F1	19.10	C61G7.5	\$ 177.00	F1	19.16
C46D60-3FI	\$ 750.00	F1	19.13	C48D85-3FI	\$ 921.00	F1	19.13	C61G7.5SC	\$ 190.00	F1	19.17
C46D62.5	\$ 589.00	F1	19.10	C48D87.5	\$ 846.00	F1	19.10	C64D10	\$ 236.00	F1	19.11
C46D62.5-3FI	\$ 777.00	F1	19.13	C48D87.5-3FI	\$ 948.00	F1	19.13	C64D10-3FI	\$ 290.00	F1	19.14
C46D65	\$ 611.00	F1	19.10	C48D90	\$ 884.00	F1	19.10	C64D14	\$ 258.00	F1	19.11
C46D65-3FI	\$ 782.00	F1	19.13	C48D90-3FI	\$ 974.00	F1	19.13	C64D14-3FI	\$ 311.00	F1	19.14
C46D70	\$ 632.00	F1	19.10	C48D95	\$ 916.00	F1	19.10	C64D15	\$ 263.00	F1	19.11
C46D70-3FI	\$ 803.00	F1	19.13	C48D95-3FI	\$ 1,012.00	F1	19.13	C64D15-3FI	\$ 332.00	F1	19.14
C46D75	\$ 696.00	F1	19.10	C48G100	\$ 921.00	F1	19.10	C64D17.5	\$ 300.00	F1	19.11
C46D75-3FI	\$ 825.00	F1	19.13	C48G100-3FI	\$ 1,033.00	F1	19.13	C64D17.5-3FI	\$ 343.00	F1	19.14
C46D77.5	\$ 739.00	F1	19.10	C48G105	\$ 963.00	F2	19.10	C64D2.2	\$ 156.00	F1	19.11
C46D77.5-3FI	\$ 841.00	F1	19.13	C48G105-3FI	\$ 1,280.00	F2	19.13	C64D2.2-3FI	\$ 236.00	F1	19.14
C46G52.5	\$ 514.00	F1	19.10	C48G110	\$ 1,012.00	F2	19.10	C64D20	\$ 316.00	F1	19.11
C46G52.5-3FI	\$ 685.00	F1	19.13	C48G110-3FI	\$ 1,310.00	F2	19.13	C64D20-3FI	\$ 386.00	F1	19.14
C46G55	\$ 530.00	F1	19.10	C48G115	\$ 1,033.00	F2	19.10	C64D25	\$ 343.00	F1	19.11
C46G55-3FI	\$ 707.00	F1	19.13	C48G115-3FI	\$ 1,350.00	F2	19.13	C64D3	\$ 161.00	F1	19.11
C46G57.5	\$ 552.00	F1	19.10	C48G120	\$ 1,054.00	F2	19.10	C64D3-3FI	\$ 242.00	F1	19.14
C46G57.5-3FI	\$ 728.00	F1	19.13	C48G120-3FI	\$ 1,390.00	F2	19.13	C64D30	\$ 375.00	F1	19.11
C46G60	\$ 562.00	F1	19.10	C48G80	\$ 749.00	F1	19.10	C64D4	\$ 167.00	F1	19.11
C46G60-3FI	\$ 739.00	F1	19.13	C48G80-3FI	\$ 856.00	F1	19.13	C64D5	\$ 177.00	F1	19.11
C46G62.5	\$ 578.00	F1	19.10	C48G85	\$ 792.00	F1	19.10	C64D5-3FI	\$ 247.00	F1	19.14
C46G62.5-3FI	\$ 766.00	F1	19.13	C48G85-3FI	\$ 910.00	F1	19.13	C64D7.5	\$ 215.00	F1	19.11
C46G65	\$ 600.00	F1	19.10	C48G87.5	\$ 835.00	F1	19.10	C64D7.5-3FI	\$ 258.00	F1	19.14
C46G65-3FI	\$ 771.00	F1	19.13	C48G87.5-3FI	\$ 937.00	F1	19.13	C64G10	\$ 225.00	F1	19.11
C46G70	\$ 621.00	F1	19.10	C48G90	\$ 873.00	F1	19.10	C64G10-3FI	\$ 300.00	F1	19.14
C46G70-3FI	\$ 792.00	F1	19.13	C48G90-3FI	\$ 963.00	F1	19.13	C64G14	\$ 247.00	F1	19.11
C46G75	\$ 685.00	F1	19.10	C48G95	\$ 905.00	F1	19.10	C64G14-3FI	\$ 321.00	F1	19.14
C46G75-3FI	\$ 814.00	F1	19.13	C48G95-3FI	\$ 1,001.00	F1	19.13	C64G15	\$ 252.00	F1	19.11
C46G77.5	\$ 728.00	F1	19.10	C48R100	\$ 932.00	F1	19.10	C64G15-3FI	\$ 332.00	F1	19.14
C46G77.5-3FI	\$ 830.00	F1	19.13	C48R100-3FI	\$ 1,044.00	F1	19.13	C64G17.5	\$ 289.00	F1	19.11
C46R52.5	\$ 525.00	F1	19.10	C48R105	\$ 974.00	F2	19.10	C64G17.5-3FI	\$ 375.00	F1	19.14
C46R52.5-3FI	\$ 696.00	F1	19.13	C48R105-3FI	\$ 1,291.00	F2	19.13	C64G2.2	\$ 145.00	F1	19.11
C46R55	\$ 541.00	F1	19.10	C48R110	\$ 1,023.00	F2	19.10	C64G2.2-3FI	\$ 225.00	F1	19.14
C46R55-3FI	\$ 718.00	F1	19.13	C48R110-3FI	\$ 1,321.00	F2	19.13	C64G20	\$ 305.00	F1	19.11
C46R57.5	\$ 563.00	F1	19.10	C48R115	\$ 1,044.00	F2	19.10	C64G20-3FI	\$ 428.00	F1	19.14
C46R57.5-3FI	\$ 739.00	F1	19.13	C48R115-3FI	\$ 1,361.00	F2	19.13	C64G25	\$ 332.00	F1	19.11
C46R60	\$ 573.00	F1	19.10	C48R120	\$ 1,065.00	F2	19.10	C64G3	\$ 150.00	F1	19.11
C46R60-3FI	\$ 750.00	F1	19.13	C48R120-3FI	\$ 1,401.00	F2	19.13	C64G3-3FI	\$ 231.00	F1	19.14
C46R62.5	\$ 589.00	F1	19.10	C48R80	\$ 760.00	F1	19.10	C64G30	\$ 364.00	F1	19.11
C46R62.5-3FI	\$ 777.00	F1	19.13	C48R80-3FI	\$ 867.00	F1	19.13	C64G4	\$ 156.00	F1	19.11
C46R65	\$ 611.00	F1	19.10	C48R85	\$ 803.00	F1	19.10	C64G4-3FI	\$ 236.00	F1	19.14
C46R65-3FI	\$ 782.00	F1	19.13	C48R85-3FI	\$ 921.00	F1	19.13	C64G5	\$ 166.00	F1	19.11
C46R70	\$ 632.00	F1	19.10	C48R87.5	\$ 846.00	F1	19.10	C64G5-3FI	\$ 247.00	F1	19.14
C46R70-3FI	\$ 803.00	F1	19.13	C48R87.5-3FI	\$ 948.00	F1	19.13	C64G7.5	\$ 204.00	F1	19.11
C46R75	\$ 696.00	F1	19.10	C48R90	\$ 884.00	F1	19.10	C64G7.5-3FI	\$ 279.00	F1	19.14

C64R10 – CADP40-10

Alphanumeric

0

Catalog number	List price	Discount schedule	Page number	Catalog number	List price	Discount schedule	Page number	Catalog number	List price	Discount schedule	Page number
C64R10	\$ 236.00	F1	19.11	C66G60	\$ 589.00	F1	19.11	C68R110	\$ 1,061.00	F2	19.11
C64R10-3FI	\$ 311.00	F1	19.14	C66G60-3FI	\$ 749.00	F1	19.14	C68R110-3FI	\$ 1,370.00	F2	19.14
C64R14	\$ 258.00	F1	19.11	C66G70	\$ 642.00	F1	19.11	C68R115	\$ 1,085.00	F2	19.11
C64R14-3FI	\$ 332.00	F1	19.14	C66G70-3FI	\$ 803.00	F1	19.14	C68R115-3FI	\$ 1,415.00	F2	19.14
C64R15	\$ 263.00	F1	19.11	C66G75	\$ 696.00	F1	19.11	C68R120	\$ 1,103.00	F2	19.11
C64R15-3FI	\$ 343.00	F1	19.14	C66G75-3FI	\$ 830.00	F1	19.14	C68R120-3FI	\$ 1,451.00	F2	19.14
C64R17.5	\$ 300.00	F1	19.11	C66G80	\$ 771.00	F1	19.11	C68R125	\$ 1,286.00	F2	19.11
C64R17.5-3FI	\$ 386.00	F1	19.14	C66G80-3FI	\$ 910.00	F1	19.14	C68R125-3FI	\$ 1,581.00	F2	19.14
C64R2.2	\$ 156.00	F1	19.11	C66R60	\$ 600.00	F1	19.11	C68R130	\$ 1,353.00	F2	19.11
C64R2.2-3FI	\$ 236.00	F1	19.14	C66R60-3FI	\$ 760.00	F1	19.14	C68R130-3FI	\$ 1,646.00	F2	19.14
C64R20	\$ 316.00	F1	19.11	C66R70	\$ 653.00	F1	19.11	C68R135	\$ 1,366.00	F2	19.11
C64R20-3FI	\$ 439.00	F1	19.14	C66R70-3FI	\$ 814.00	F1	19.14	C68R135-3FI	\$ 1,661.00	F2	19.14
C64R25	\$ 343.00	F1	19.11	C66R75	\$ 707.00	F1	19.11	C68R90	\$ 889.00	F1	19.11
C64R3	\$ 161.00	F1	19.11	C66R75-3FI	\$ 841.00	F1	19.14	C68R90-3FI	\$ 1,012.00	F1	19.14
C64R3-3FI	\$ 242.00	F1	19.14	C66R80	\$ 782.00	F1	19.11	C68R95	\$ 921.00	F1	19.11
C64R30	\$ 375.00	F1	19.11	C66R80-3FI	\$ 921.00	F1	19.14	C68R95-3FI	\$ 1,033.00	F1	19.14
C64R4	\$ 167.00	F1	19.11	C68D100	\$ 974.00	F1	19.11	C73W9V2	\$ 17.60	RA	10.132
C64R4-3FI	\$ 247.00	F1	19.14	C68D100-3FI	\$ 1,055.00	F1	19.14	C73W9V6	\$ 29.00	RA	10.132
C64R5	\$ 177.00	F1	19.11	C68D105	\$ 1,003.00	F2	19.11	C73WSV2	\$ 17.60	RA	10.131
C64R5-3FI	\$ 258.00	F1	19.14	C68D105-3FI	\$ 1,333.00	F2	19.14	C73WSV6	\$ 29.00	RA	10.131
C64R7.5	\$ 215.00	F1	19.11	C68D110	\$ 1,061.00	F2	19.11	C73WV9V2	\$ 17.60	RA	10.132
C64R7.5-3FI	\$ 290.00	F1	19.14	C68D110-3FI	\$ 1,370.00	F2	19.14	C73WV9V6	\$ 29.00	RA	10.132
C65D25-3FI	\$ 461.00	F1	19.14	C68D115	\$ 1,085.00	F2	19.11	C83W9LNV2	\$ 28.20	RA	10.135
C65D30-3FI	\$ 514.00	F1	19.14	C68D115-3FI	\$ 1,415.00	F2	19.14	C83W9LPV2	\$ 28.20	RA	10.135
C65D35	\$ 429.00	F1	19.11	C68D120	\$ 1,103.00	F2	19.11	C83W9V2	\$ 13.50	RA	10.134
C65D35-3FI	\$ 568.00	F1	19.14	C68D120-3FI	\$ 1,451.00	F2	19.14	C83W9V6	\$ 22.70	RA	10.134
C65D40	\$ 461.00	F1	19.11	C68D125	\$ 1,286.00	F2	19.11	C83WSV2	\$ 13.50	RA	10.133
C65D40-3FI	\$ 627.00	F1	19.14	C68D125-3FI	\$ 1,581.00	F2	19.14	CA5-01	\$ 15.00	ABA	1.16
C65D45	\$ 504.00	F1	19.11	C68D130	\$ 1,353.00	F2	19.11	CA5-04E	\$ 30.00	ABA	1.16
C65D45-3FI	\$ 653.00	F1	19.14	C68D130-3FI	\$ 1,646.00	F2	19.14	CA5-04M	\$ 30.00	ABA	1.16
C65D50	\$ 546.00	F1	19.11	C68D135	\$ 1,366.00	F2	19.11	CA5-04N	\$ 30.00	ABA	7.7
C65D50-3FI	\$ 707.00	F1	19.14	C68D135-3FI	\$ 1,661.00	F2	19.14	CA5-10	\$ 15.00	ABA	1.16
C65G25-3FI	\$ 450.00	F1	19.14	C68D90	\$ 889.00	F1	19.11	CA5-11/11E	\$ 30.00	ABA	1.16
C65G30-3FI	\$ 503.00	F1	19.14	C68D90-3FI	\$ 1,012.00	F1	19.14	CA5-11/11M	\$ 30.00	ABA	1.16
C65G35	\$ 418.00	F1	19.11	C68D95	\$ 921.00	F1	19.11	CA5-13M	\$ 30.00	ABA	1.16
C65G35-3FI	\$ 557.00	F1	19.14	C68D95-3FI	\$ 1,033.00	F1	19.14	CA5-22E	\$ 30.00	ABA	1.16
C65G40	\$ 450.00	F1	19.11	C68G100	\$ 963.00	F1	19.11	CA5-22ERT	\$ 35.00	ABA	1.10
C65G40-3FI	\$ 616.00	F1	19.14	C68G100-3FI	\$ 1,044.00	F1	19.14	CA5-22M	\$ 30.00	ABA	1.16
C65G45	\$ 493.00	F1	19.11	C68G105	\$ 992.00	F2	19.11	CA5-22N	\$ 30.00	ABA	7.7
C65G45-3FI	\$ 642.00	F1	19.14	C68G105-3FI	\$ 1,322.00	F2	19.14	CA5-31E	\$ 30.00	ABA	1.16
C65G50	\$ 535.00	F1	19.11	C68G110	\$ 1,050.00	F2	19.11	CA5-31ERT	\$ 35.00	ABA	1.10
C65G50-3FI	\$ 696.00	F1	19.14	C68G110-3FI	\$ 1,359.00	F2	19.14	CA5-31M	\$ 30.00	ABA	1.16
C65R25-3FI	\$ 461.00	F1	19.14	C68G115	\$ 1,074.00	F2	19.11	CA5-40E	\$ 30.00	ABA	1.16
C65R30-3FI	\$ 514.00	F1	19.14	C68G115-3FI	\$ 1,404.00	F2	19.14	CA5-40ERT	\$ 35.00	ABA	1.10
C65R35	\$ 429.00	F1	19.11	C68G120	\$ 1,092.00	F2	19.11	CA5-40N	\$ 30.00	ABA	1.16
C65R35-3FI	\$ 568.00	F1	19.14	C68G120-3FI	\$ 1,440.00	F2	19.14	CA5D-01	\$ 75.00	D	1.110
C65R40	\$ 461.00	F1	19.11	C68G125	\$ 1,275.00	F2	19.11	CA5D-11	\$ 60.00	D	1.110
C65R40-3FI	\$ 627.00	F1	19.14	C68G125-3FI	\$ 1,570.00	F2	19.14	CA6-11E	\$ 15.00	AA	4.11
C65R45	\$ 504.00	F1	19.11	C68G130	\$ 1,342.00	F2	19.11	CA6-11E-F	\$ 15.00	AA	4.11
C65R45-3FI	\$ 653.00	F1	19.14	C68G130-3FI	\$ 1,635.00	F2	19.14	CA6-11E-P	\$ 15.00	AA	4.11
C65R50	\$ 546.00	F1	19.11	C68G135	\$ 1,355.00	F2	19.11	CA6-11K	\$ 15.00	AA	4.11
C65R50-3RI	\$ 707.00	F1	19.14	C68G135-3FI	\$ 1,650.00	F2	19.14	CA6-11K-F	\$ 15.00	AA	4.11
C66D60	\$ 600.00	F1	19.11	C68G90	\$ 878.00	F1	19.11	CA6-11K-P	\$ 15.00	AA	4.11
C66D60-3FI	\$ 760.00	F1	19.14	C68G90-3FI	\$ 1,001.00	F1	19.14	CA6-11M	\$ 15.00	AA	4.11
C66D70	\$ 653.00	F1	19.11	C68G95	\$ 910.00	F1	19.11	CA6-11M-F	\$ 15.00	AA	4.11
C66D70-3FI	\$ 814.00	F1	19.14	C68G95-3FI	\$ 1,022.00	F1	19.14	CA6-11M-P	\$ 15.00	AA	4.11
C66D75	\$ 707.00	F1	19.11	C68R100	\$ 974.00	F1	19.11	CA6-11N	\$ 15.00	AA	4.11
C66D75-3FI	\$ 841.00	F1	19.14	C68R100-3FI	\$ 1,055.00	F1	19.14	CA6-11N-F	\$ 15.00	AA	4.11
C66D80	\$ 782.00	F1	19.11	C68R105	\$ 1,003.00	F2	19.11	CA6-11N-P	\$ 15.00	AA	4.11
C66D80-3FI	\$ 921.00	F1	19.14	C68R105-3FI	\$ 1,333.00	F2	19.14	CADP40-10	\$ 10.00	DP	1.98

CADP40-11 – CBG-KESP6IT5R

Catalog number	List price	Discount schedule	Page number	Catalog number	List price	Discount schedule	Page number	Catalog number	List price	Discount schedule	Page number
CADP40-11	\$ 10.00	DP	1.98	CBG-2BSKE	\$ 35.00	CC	8.70	CBG-3SLLIY	\$ 49.00	CC	8.83
CADP60-10	\$ 10.00	DP	1.98	CBG-2BSKIC	\$ 49.00	CC	8.82	CBG-3SLLR	\$ 35.00	CC	8.71
CADP60-11	\$ 10.00	DP	1.98	CBG-2BSKIG	\$ 49.00	CC	8.82	CBG-3SLR	\$ 35.00	CC	8.71
CAF6-02E	\$ 15.00	AA	4.11	CBG-2BSKIL	\$ 49.00	CC	8.82	CBG-3SRK	\$ 35.00	CC	8.71
CAF6-02K	\$ 15.00	AA	4.11	CBG-2BSKIR	\$ 49.00	CC	8.82	CBG-3SRKE	\$ 35.00	CC	8.71
CAF6-02M	\$ 15.00	AA	4.11	CBG-2BSKIY	\$ 49.00	CC	8.82	CBG-3SRKIC	\$ 49.00	CC	8.83
CAF6-02N	\$ 15.00	AA	4.11	CBG-2BSKR	\$ 35.00	CC	8.70	CBG-3SRKIG	\$ 49.00	CC	8.83
CAF6-11E	\$ 15.00	AA	4.11	CBG-2BSL	\$ 35.00	CC	8.70	CBG-3SRKIL	\$ 49.00	CC	8.83
CAF6-11K	\$ 15.00	AA	4.11	CBG-2BSLE	\$ 35.00	CC	8.70	CBG-3SRKIR	\$ 49.00	CC	8.83
CAF6-11M	\$ 15.00	AA	4.11	CBG-2BSLIC	\$ 49.00	CC	8.82	CBG-3SRKIY	\$ 49.00	CC	8.83
CAF6-11N	\$ 15.00	AA	4.11	CBG-2BSLIG	\$ 49.00	CC	8.82	CBG-3SRKR	\$ 35.00	CC	8.71
CAF6-20E	\$ 15.00	AA	4.11	CBG-2BSLIL	\$ 49.00	CC	8.82	CBG-3SRL	\$ 35.00	CC	8.71
CAF6-20K	\$ 15.00	AA	4.11	CBG-2BSLIR	\$ 49.00	CC	8.82	CBG-3SRLLE	\$ 35.00	CC	8.71
CAF6-20M	\$ 15.00	AA	4.11	CBG-2BSLIY	\$ 49.00	CC	8.82	CBG-3SRLIC	\$ 49.00	CC	8.83
CAF6-20N	\$ 15.00	AA	4.11	CBG-2BSLR	\$ 35.00	CC	8.70	CBG-3SRLIG	\$ 49.00	CC	8.83
CAL16-11A	\$ 66.00	AB	1.109	CBG-3MIKL	\$ 37.00	CC	8.83	CBG-3SRLIL	\$ 49.00	CC	8.83
CAL16-11B	\$ 66.00	AB	1.109	CBG-3MK	\$ 23.00	CC	8.71	CBG-3SRLIR	\$ 49.00	CC	8.83
CAL16-11C	\$ 66.00	AB	1.109	CBG-3MKE	\$ 23.00	CC	8.71	CBG-3SRLIY	\$ 49.00	CC	8.83
CAL16-11D	\$ 66.00	AB	1.109	CBG-3MKIC	\$ 37.00	CC	8.83	CBG-3SRLR	\$ 35.00	CC	8.71
CAL16-11E	\$ 75.00	AB	1.109	CBG-3MKIG	\$ 37.00	CC	8.83	CBG-ESCH	\$ 2.00	CC	8.67
CAL16-11L	\$ 120.00	AB	1.109	CBG-3MKIR	\$ 37.00	CC	8.83	CBG-KESP4IF1R	\$ 67.50	CC	8.79
CAL16-11M	\$ 120.00	AB	1.109	CBG-3MKIY	\$ 37.00	CC	8.83	CBG-KESP4IF6R	\$ 67.50	CC	8.79
CAL16-11N	\$ 120.00	AB	1.109	CBG-3MKR	\$ 23.00	CC	8.71	CBG-KESP4IF7R	\$ 67.50	CC	8.79
CAL16-11P	\$ 120.00	AB	1.109	CBG-3ML	\$ 23.00	CC	8.71	CBG-KESP4IF8R	\$ 67.50	CC	8.79
CAL18-11	\$ 30.00	ABA	1.16	CBG-3MLE	\$ 23.00	CC	8.71	CBG-KESP4IF9R	\$ 67.50	CC	8.79
CAL5-11	\$ 30.00	ABA	1.16	CBG-3MLIC	\$ 37.00	CC	8.83	CBG-KESP4IFL1R	\$ 76.50	CC	8.79
CAL5-11B	\$ 30.00	ABA	1.16	CBG-3MLIG	\$ 37.00	CC	8.83	CBG-KESP4IFL2R	\$ 82.50	CC	8.79
CBG-2AMK	\$ 23.00	CC	8.70	CBG-3MLIL	\$ 37.00	CC	8.83	CBG-KESP4IFL8R	\$ 76.50	CC	8.79
CBG-2AMKE	\$ 23.00	CC	8.70	CBG-3MLIR	\$ 37.00	CC	8.83	CBG-KESP4IR	\$ 44.00	CC	8.79
CBG-2AMKIC	\$ 37.00	CC	8.82	CBG-3MLIY	\$ 37.00	CC	8.83	CBG-KESP4IR1R	\$ 71.50	CC	8.79
CBG-2AMKIG	\$ 37.00	CC	8.82	CBG-3MLR	\$ 23.00	CC	8.71	CBG-KESP4IR2R	\$ 71.50	CC	8.79
CBG-2AMKIL	\$ 37.00	CC	8.82	CBG-3SK	\$ 35.00	CC	8.71	CBG-KESP4IT1R	\$ 102.50	CC	8.79
CBG-2AMKIR	\$ 37.00	CC	8.82	CBG-3SKE	\$ 35.00	CC	8.71	CBG-KESP4IT2R	\$ 102.50	CC	8.79
CBG-2AMKIY	\$ 37.00	CC	8.82	CBG-3SKIC	\$ 49.00	CC	8.83	CBG-KESP4IT3R	\$ 102.50	CC	8.79
CBG-2AMKR	\$ 23.00	CC	8.70	CBG-3SKIG	\$ 49.00	CC	8.83	CBG-KESP4IT4R	\$ 102.50	CC	8.79
CBG-2AML	\$ 23.00	CC	8.70	CBG-3SKIL	\$ 49.00	CC	8.83	CBG-KESP4IT5R	\$ 102.50	CC	8.79
CBG-2AMLE	\$ 23.00	CC	8.70	CBG-3SKIR	\$ 49.00	CC	8.83	CBG-KESP4IT6R	\$ 102.50	CC	8.79
CBG-2AMLIC	\$ 37.00	CC	8.82	CBG-3SKIY	\$ 49.00	CC	8.83	CBG-KESP4IT7R	\$ 102.50	CC	8.79
CBG-2AMLIG	\$ 37.00	CC	8.82	CBG-3SKR	\$ 35.00	CC	8.71	CBG-KESP4IT8R	\$ 102.50	CC	8.79
CBG-2AMLIL	\$ 37.00	CC	8.82	CBG-3SL	\$ 35.00	CC	8.71	CBG-KESP4ITL5R	\$ 111.50	CC	8.79
CBG-2AMLIR	\$ 37.00	CC	8.82	CBG-3SLE	\$ 35.00	CC	8.71	CBG-KESP4ITL6R	\$ 111.50	CC	8.79
CBG-2AMLIY	\$ 37.00	CC	8.82	CBG-3SLIC	\$ 49.00	CC	8.83	CBG-KESP4ITL7R	\$ 111.50	CC	8.79
CBG-2AMLR	\$ 23.00	CC	8.70	CBG-3SLIG	\$ 49.00	CC	8.83	CBG-KESP4ITL8R	\$ 111.50	CC	8.79
CBG-2BMIKG	\$ 37.00	CC	8.82	CBG-3SLIL	\$ 49.00	CC	8.83	CBG-KESP4R	\$ 44.00	CC	8.67
CBG-2BMIKL	\$ 37.00	CC	8.82	CBG-3SLIR	\$ 49.00	CC	8.83	CBG-KESP6IT2R	\$ 114.50	CC	8.81
CBG-2BMK	\$ 23.00	CC	8.70	CBG-3SLIY	\$ 49.00	CC	8.83	CBG-KESP6IT3R	\$ 114.50	CC	8.81
CBG-2BMKE	\$ 23.00	CC	8.70	CBG-3SLK	\$ 35.00	CC	8.71	CBG-KESP6IT4R	\$ 114.50	CC	8.81
CBG-2BMKIC	\$ 37.00	CC	8.82	CBG-3SLKE	\$ 35.00	CC	8.71	CBG-KESP6IF1R	\$ 79.50	CC	8.81
CBG-2BMKIR	\$ 37.00	CC	8.82	CBG-3SLKIC	\$ 49.00	CC	8.83	CBG-KESP6IF6R	\$ 79.50	CC	8.81
CBG-2BMKIY	\$ 37.00	CC	8.82	CBG-3SLKIG	\$ 49.00	CC	8.83	CBG-KESP6IF7R	\$ 79.50	CC	8.81
CBG-2BMKR	\$ 23.00	CC	8.70	CBG-3SLKIL	\$ 49.00	CC	8.83	CBG-KESP6IF8R	\$ 79.50	CC	8.81
CBG-2BML	\$ 23.00	CC	8.70	CBG-3SLKIR	\$ 49.00	CC	8.83	CBG-KESP6IF9R	\$ 79.50	CC	8.81
CBG-2BMLE	\$ 23.00	CC	8.70	CBG-3SLKIY	\$ 49.00	CC	8.83	CBG-KESP6IFL1R	\$ 88.50	CC	8.81
CBG-2BMLIC	\$ 37.00	CC	8.82	CBG-3SLKR	\$ 35.00	CC	8.71	CBG-KESP6IFL2R	\$ 94.50	CC	8.81
CBG-2BMLIG	\$ 37.00	CC	8.82	CBG-3SLL	\$ 35.00	CC	8.71	CBG-KESP6IFL8R	\$ 88.50	CC	8.81
CBG-2BMLIL	\$ 37.00	CC	8.82	CBG-3SLE	\$ 35.00	CC	8.71	CBG-KESP6IR	\$ 56.00	CC	8.81
CBG-2BMLIR	\$ 37.00	CC	8.82	CBG-3SLLIC	\$ 49.00	CC	8.83	CBG-KESP6IR1R	\$ 83.50	CC	8.81
CBG-2BMLIY	\$ 37.00	CC	8.82	CBG-3SLLIG	\$ 49.00	CC	8.83	CBG-KESP6IR2R	\$ 83.50	CC	8.81
CBG-2BMLR	\$ 23.00	CC	8.70	CBG-3SLLIL	\$ 49.00	CC	8.83	CBG-KESP6IT1R	\$ 114.50	CC	8.81
CBG-2BSK	\$ 35.00	CC	8.70	CBG-3SLLIR	\$ 49.00	CC	8.83	CBG-KESP6IT5R	\$ 114.50	CC	8.81

CBG-KESP6IT6R – CBG-KPPIR1*

Alphanumeric

0

Catalog number	List price	Discount schedule	Page number	Catalog number	List price	Discount schedule	Page number	Catalog number	List price	Discount schedule	Page number
CBG-KESP6IT6R	\$ 114.50	CC	8.81	CBG-KLF8*	\$ 51.50	CC	8.86	CBG-KPM40IF1*	\$ 67.50	CC	8.76
CBG-KESP6IT7R	\$ 114.50	CC	8.81	CBG-KLF9*	\$ 51.50	CC	8.86	CBG-KPM40IF6*	\$ 67.50	CC	8.76
CBG-KESP6IT8R	\$ 114.50	CC	8.81	CBG-KLFL1*	\$ 60.50	CC	8.86	CBG-KPM40IF7*	\$ 67.50	CC	8.76
CBG-KESP6ITL5R	\$ 123.50	CC	8.81	CBG-KLFL2*	\$ 66.50	CC	8.86	CBG-KPM40IF8*	\$ 67.50	CC	8.76
CBG-KESP6ITL6R	\$ 123.50	CC	8.81	CBG-KLFL8*	\$ 60.50	CC	8.86	CBG-KPM40IF9*	\$ 67.50	CC	8.76
CBG-KESP6ITL7R	\$ 123.50	CC	8.81	CBG-KLFPT1*	\$ 69.50	CC	8.85	CBG-KPM40IFL1*	\$ 76.50	CC	8.76
CBG-KESP6ITL8R	\$ 123.50	CC	8.81	CBG-KLFPT6*	\$ 69.50	CC	8.85	CBG-KPM40IFL2*	\$ 82.50	CC	8.76
CBG-KESP6R	\$ 56.00	CC	8.67	CBG-KLFPT7*	\$ 69.50	CC	8.85	CBG-KPM40IFL8*	\$ 76.50	CC	8.76
CBG-KEST4IF1R	\$ 67.50	CC	8.78	CBG-KLFPT8*	\$ 69.50	CC	8.85	CBG-KPM40IR1*	\$ 71.50	CC	8.76
CBG-KEST4IF6R	\$ 67.50	CC	8.78	CBG-KLFPT9*	\$ 69.50	CC	8.85	CBG-KPM40IR2*	\$ 71.50	CC	8.76
CBG-KEST4IF7R	\$ 67.50	CC	8.78	CBG-KLFPTL1*	\$ 78.50	CC	8.85	CBG-KPM40IT1*	\$ 102.50	CC	8.76
CBG-KEST4IF8R	\$ 67.50	CC	8.78	CBG-KLFPTL2*	\$ 84.50	CC	8.85	CBG-KPM40IT2*	\$ 102.50	CC	8.76
CBG-KEST4IF9R	\$ 67.50	CC	8.78	CBG-KLFPTL8*	\$ 78.50	CC	8.85	CBG-KPM40IT3*	\$ 102.50	CC	8.76
CBG-KEST4IFL1R	\$ 76.50	CC	8.78	CBG-KLPT*	\$ 46.00	CC	8.85	CBG-KPM40IT4*	\$ 102.50	CC	8.76
CBG-KEST4IFL2R	\$ 82.50	CC	8.78	CBG-KLPT*	\$ 46.00	CC	8.85	CBG-KPM40ITL3*	\$ 111.50	CC	8.76
CBG-KEST4IFL8R	\$ 76.50	CC	8.78	CBG-KLR2*	\$ 55.50	CC	8.86	CBG-KPM40ITL4*	\$ 111.50	CC	8.76
CBG-KEST4IR	\$ 44.00	CC	8.78	CBG-KLRPT1*	\$ 73.50	CC	8.85	CBG-KPM40R	\$ 35.00	CC	8.66
CBG-KEST4IR1R	\$ 71.50	CC	8.78	CBG-KLRPT2*	\$ 73.50	CC	8.85	CBG-KPM40Y	\$ 35.00	CC	8.66
CBG-KEST4IR2R	\$ 71.50	CC	8.78	CBG-KLT1*	\$ 69.00	CC	8.86	CBG-KPM6B	\$ 39.00	CC	8.66
CBG-KEST4IT1R	\$ 102.50	CC	8.78	CBG-KLT2*	\$ 69.00	CC	8.86	CBG-KPM6I*	\$ 48.00	CC	8.77
CBG-KEST4IT2R	\$ 102.50	CC	8.78	CBG-KLT3*	\$ 69.00	CC	8.86	CBG-KPM6IF1*	\$ 71.50	CC	8.77
CBG-KEST4IT3R	\$ 102.50	CC	8.78	CBG-KLT4*	\$ 69.00	CC	8.86	CBG-KPM6IF6*	\$ 71.50	CC	8.77
CBG-KEST4IT4R	\$ 102.50	CC	8.78	CBG-KLTL3*	\$ 78.00	CC	8.86	CBG-KPM6IF7*	\$ 71.50	CC	8.77
CBG-KEST4IT5R	\$ 102.50	CC	8.78	CBG-KLTL4*	\$ 78.00	CC	8.86	CBG-KPM6IF8*	\$ 71.50	CC	8.77
CBG-KEST4IT6R	\$ 102.50	CC	8.78	CBG-KLTP1*	\$ 113.50	CC	8.85	CBG-KPM6IF9*	\$ 71.50	CC	8.77
CBG-KEST4IT7R	\$ 102.50	CC	8.78	CBG-KLTP2*	\$ 104.50	CC	8.85	CBG-KPM6IFL1*	\$ 80.50	CC	8.77
CBG-KEST4IT8R	\$ 102.50	CC	8.78	CBG-KLTP3*	\$ 104.50	CC	8.85	CBG-KPM6IFL2*	\$ 86.50	CC	8.77
CBG-KEST4ITL5R	\$ 111.50	CC	8.78	CBG-KLTP4*	\$ 104.50	CC	8.85	CBG-KPM6IFL3*	\$ 80.50	CC	8.77
CBG-KEST4ITL6R	\$ 111.50	CC	8.78	CBG-KLTP5*	\$ 104.50	CC	8.85	CBG-KPM6IR1*	\$ 75.50	CC	8.77
CBG-KEST4ITL7R	\$ 111.50	CC	8.78	CBG-KLTP6*	\$ 113.50	CC	8.85	CBG-KPM6IR2*	\$ 75.50	CC	8.77
CBG-KEST4ITL8R	\$ 111.50	CC	8.78	CBG-KPB	\$ 17.00	CC	8.64	CBG-KPM6IT1*	\$ 106.50	CC	8.77
CBG-KEST4R	\$ 44.00	CC	8.67	CBG-KPC	\$ 17.00	CC	8.64	CBG-KPM6IT2*	\$ 106.50	CC	8.77
CBG-KEST6IF1R	\$ 79.50	CC	8.80	CBG-KPEB	\$ 17.00	CC	8.64	CBG-KPM6IT3*	\$ 106.50	CC	8.77
CBG-KEST6IF6R	\$ 79.50	CC	8.80	CBG-KPEC	\$ 17.00	CC	8.64	CBG-KPM6IT4*	\$ 106.50	CC	8.77
CBG-KEST6IF7R	\$ 79.50	CC	8.80	CBG-KPEG	\$ 17.00	CC	8.64	CBG-KPM6ITL3*	\$ 115.50	CC	8.77
CBG-KEST6IF8R	\$ 79.50	CC	8.80	CBG-KPEL	\$ 17.00	CC	8.64	CBG-KPM6ITL4*	\$ 115.50	CC	8.77
CBG-KEST6IF9R	\$ 79.50	CC	8.80	CBG-KPER	\$ 17.00	CC	8.64	CBG-KPM6R	\$ 39.00	CC	8.66
CBG-KEST6IFL1R	\$ 85.50	CC	8.80	CBG-KPEW	\$ 17.00	CC	8.64	CBG-KPM6Y	\$ 39.00	CC	8.66
CBG-KEST6IFL2R	\$ 94.50	CC	8.80	CBG-KPEY	\$ 17.00	CC	8.64	CBG-KPMK40B	\$ 63.00	CC	8.66
CBG-KEST6IFL8R	\$ 88.50	CC	8.80	CBG-KPG	\$ 17.00	CC	8.64	CBG-KPMK40R	\$ 63.00	CC	8.66
CBG-KEST6IR	\$ 56.00	CC	8.80	CBG-KPI*	\$ 17.00	CC	8.74	CBG-KPPB	\$ 34.20	CC	8.65
CBG-KEST6IR1R	\$ 83.50	CC	8.80	CBG-KPIF1*	\$ 40.50	CC	8.74	CBG-KPPC	\$ 34.20	CC	8.65
CBG-KEST6IR2R	\$ 83.50	CC	8.80	CBG-KPIF6*	\$ 40.50	CC	8.74	CBG-KPPEB	\$ 34.20	CC	8.65
CBG-KEST6IT1R	\$ 114.50	CC	8.80	CBG-KPIF7*	\$ 40.50	CC	8.74	CBG-KPPEC	\$ 34.20	CC	8.65
CBG-KEST6IT2R	\$ 114.50	CC	8.80	CBG-KPIF8*	\$ 40.50	CC	8.74	CBG-KPPEG	\$ 34.20	CC	8.65
CBG-KEST6IT3R	\$ 114.50	CC	8.80	CBG-KPIF9*	\$ 40.50	CC	8.74	CBG-KPPEL	\$ 34.20	CC	8.65
CBG-KEST6IT4R	\$ 114.50	CC	8.80	CBG-KPIFL1*	\$ 49.50	CC	8.74	CBG-KPPER	\$ 34.20	CC	8.65
CBG-KEST6IT5R	\$ 114.50	CC	8.80	CBG-KPIFL2*	\$ 55.50	CC	8.74	CBG-KPPEW	\$ 34.20	CC	8.65
CBG-KEST6IT6R	\$ 114.50	CC	8.80	CBG-KPIFL8*	\$ 49.50	CC	8.74	CBG-KPPEY	\$ 34.20	CC	8.65
CBG-KEST6IT7R	\$ 114.50	CC	8.80	CBG-KPIR1*	\$ 44.50	CC	8.74	CBG-KPPG	\$ 34.20	CC	8.65
CBG-KEST6IT8R	\$ 114.50	CC	8.80	CBG-KPIR2*	\$ 44.50	CC	8.74	CBG-KPPI*	\$ 34.20	CC	8.75
CBG-KEST6ITL5R	\$ 123.50	CC	8.80	CBG-KPIT1*	\$ 75.50	CC	8.74	CBG-KPPIF1*	\$ 57.70	CC	8.75
CBG-KEST6ITL6R	\$ 123.50	CC	8.80	CBG-KPIT2*	\$ 75.50	CC	8.74	CBG-KPPIF6*	\$ 57.70	CC	8.75
CBG-KEST6ITL7R	\$ 123.50	CC	8.80	CBG-KPIT3*	\$ 75.50	CC	8.74	CBG-KPPIF7*	\$ 57.70	CC	8.75
CBG-KEST6ITL8R	\$ 123.50	CC	8.80	CBG-KPIT4*	\$ 75.50	CC	8.74	CBG-KPPIF8*	\$ 57.70	CC	8.75
CBG-KEST6R	\$ 56.00	CC	8.67	CBG-KPITL3*	\$ 84.50	CC	8.74	CBG-KPPIF9*	\$ 57.70	CC	8.75
CBG-KLF*	\$ 28.00	CC	8.86	CBG-KPITL4*	\$ 84.50	CC	8.74	CBG-KPPIFL1*	\$ 66.70	CC	8.75
CBG-KLF1*	\$ 51.50	CC	8.86	CBG-KPL	\$ 17.00	CC	8.64	CBG-KPPIFL2*	\$ 72.70	CC	8.75
CBG-KLF6*	\$ 51.50	CC	8.86	CBG-KPM40B	\$ 35.00	CC	8.66	CBG-KPPIFL8*	\$ 66.70	CC	8.75
CBG-KLF7*	\$ 51.50	CC	8.86	CBG-KPM40I*	\$ 44.40	CC	8.76	CBG-KPPIR1*	\$ 61.70	CC	8.75

CBG-KPPIR2* – CBG-MEST4IF6R

Catalog number	List price	Discount schedule	Page number	Catalog number	List price	Discount schedule	Page number	Catalog number	List price	Discount schedule	Page number
CBG-KPPIR2*	\$ 61.70	CC	8.75	CBG-M2BSLIC	\$ 49.00	CC	8.82	CBG-M3SRKIY	\$ 49.00	CC	8.83
CBG-KPPIT1*	\$ 92.70	CC	8.75	CBG-M2BSLIG	\$ 49.00	CC	8.82	CBG-M3SRKR	\$ 35.00	CC	8.71
CBG-KPPIT2*	\$ 92.70	CC	8.75	CBG-M2BSLIL	\$ 49.00	CC	8.82	CBG-M3SRL	\$ 35.00	CC	8.71
CBG-KPPIT3*	\$ 92.70	CC	8.75	CBG-M2BSLIR	\$ 49.00	CC	8.82	CBG-M3SRLE	\$ 35.00	CC	8.71
CBG-KPPIT4*	\$ 92.70	CC	8.75	CBG-M2BSLIY	\$ 49.00	CC	8.82	CBG-M3SRLIC	\$ 49.00	CC	8.83
CBG-KPPITL3*	\$ 101.70	CC	8.75	CBG-M2BSLR	\$ 35.00	CC	8.70	CBG-M3SRLIG	\$ 49.00	CC	8.83
CBG-KPPITL4*	\$ 101.70	CC	8.75	CBG-M3MK	\$ 23.00	CC	8.71	CBG-M3SRLIL	\$ 49.00	CC	8.83
CBG-KPPL	\$ 34.20	CC	8.65	CBG-M3MKE	\$ 23.00	CC	8.71	CBG-M3SRLIR	\$ 49.00	CC	8.83
CBG-KPPR	\$ 34.20	CC	8.65	CBG-M3MKIC	\$ 37.00	CC	8.83	CBG-M3SRLIY	\$ 49.00	CC	8.83
CBG-KPPW	\$ 34.20	CC	8.65	CBG-M3MKIG	\$ 37.00	CC	8.83	CBG-M3SRLR	\$ 35.00	CC	8.71
CBG-KPPY	\$ 34.20	CC	8.65	CBG-M3MKIL	\$ 37.00	CC	8.83	CBG-MESP4IF1R	\$ 69.50	CC	8.79
CBG-KPR	\$ 17.00	CC	8.64	CBG-M3MKIR	\$ 37.00	CC	8.83	CBG-MESP4IF6R	\$ 69.50	CC	8.79
CBG-KPW	\$ 17.00	CC	8.64	CBG-M3MKIY	\$ 37.00	CC	8.83	CBG-MESP4IF7R	\$ 69.50	CC	8.79
CBG-KPY	\$ 17.00	CC	8.64	CBG-M3ML	\$ 23.00	CC	8.71	CBG-MESP4IF8R	\$ 69.50	CC	8.79
CBG-KSP10K	\$ 125.00	CC	8.73	CBG-M3MLE	\$ 23.00	CC	8.71	CBG-MESP4IF9R	\$ 69.50	CC	8.79
CBG-KSP10K4XP	\$ 105.00	CC	8.73	CBG-M3MLIC	\$ 37.00	CC	8.83	CBG-MESP4IFL1R	\$ 78.50	CC	8.79
CBG-KSP5K	\$ 125.00	CC	8.73	CBG-M3MLIG	\$ 37.00	CC	8.83	CBG-MESP4IFL2R	\$ 84.50	CC	8.79
CBG-KSP5K4XP	\$ 105.00	CC	8.73	CBG-M3MLIL	\$ 37.00	CC	8.83	CBG-MESP4IFL8R	\$ 78.50	CC	8.79
CBG-M2AMK	\$ 23.00	CC	8.70	CBG-M3MLIR	\$ 37.00	CC	8.83	CBG-MESP4IR	\$ 46.00	CC	8.79
CBG-M2AMKE	\$ 23.00	CC	8.70	CBG-M3MLIY	\$ 37.00	CC	8.83	CBG-MESP4IR1R	\$ 73.50	CC	8.79
CBG-M2AMKIC	\$ 37.00	CC	8.82	CBG-M3MLR	\$ 23.00	CC	8.71	CBG-MESP4IR2R	\$ 73.50	CC	8.79
CBG-M2AMKIG	\$ 37.00	CC	8.82	CBG-M3MR	\$ 23.00	CC	8.71	CBG-MESP4IT1R	\$ 104.50	CC	8.79
CBG-M2AMKIL	\$ 37.00	CC	8.82	CBG-M3SK	\$ 35.00	CC	8.71	CBG-MESP4IT2R	\$ 104.50	CC	8.79
CBG-M2AMKIR	\$ 37.00	CC	8.82	CBG-M3SKE	\$ 35.00	CC	8.71	CBG-MESP4IT3R	\$ 104.50	CC	8.79
CBG-M2AMKIY	\$ 37.00	CC	8.82	CBG-M3SKIC	\$ 49.00	CC	8.83	CBG-MESP4IT4R	\$ 104.50	CC	8.79
CBG-M2AMKR	\$ 23.00	CC	8.70	CBG-M3SKIG	\$ 49.00	CC	8.83	CBG-MESP4IT5R	\$ 104.50	CC	8.79
CBG-M2AML	\$ 23.00	CC	8.70	CBG-M3SKIL	\$ 49.00	CC	8.83	CBG-MESP4IT6R	\$ 104.50	CC	8.79
CBG-M2AMLE	\$ 23.00	CC	8.70	CBG-M3SKIR	\$ 49.00	CC	8.83	CBG-MESP4IT7R	\$ 104.50	CC	8.79
CBG-M2AMLIC	\$ 37.00	CC	8.82	CBG-M3SKIY	\$ 49.00	CC	8.83	CBG-MESP4IT8R	\$ 104.50	CC	8.79
CBG-M2AMLIG	\$ 37.00	CC	8.82	CBG-M3SKR	\$ 35.00	CC	8.71	CBG-MESP4ITL5R	\$ 113.50	CC	8.79
CBG-M2AMLIL	\$ 37.00	CC	8.82	CBG-M3SL	\$ 35.00	CC	8.71	CBG-MESP4ITL6R	\$ 113.50	CC	8.79
CBG-M2AMLIR	\$ 37.00	CC	8.82	CBG-M3SLE	\$ 35.00	CC	8.71	CBG-MESP4ITL7R	\$ 113.50	CC	8.79
CBG-M2AMLIY	\$ 37.00	CC	8.82	CBG-M3SLIC	\$ 49.00	CC	8.83	CBG-MESP4ITL8R	\$ 113.50	CC	8.79
CBG-M2AMLR	\$ 23.00	CC	8.70	CBG-M3SLIG	\$ 49.00	CC	8.83	CBG-MESP4R	\$ 46.00	CC	8.67
CBG-M2BMK	\$ 23.00	CC	8.70	CBG-M3SLIL	\$ 49.00	CC	8.83	CBG-MESP61T1R	\$ 116.50	CC	8.81
CBG-M2BMKE	\$ 23.00	CC	8.70	CBG-M3SLIR	\$ 49.00	CC	8.83	CBG-MESP61T2R	\$ 116.50	CC	8.81
CBG-M2BMKIC	\$ 37.00	CC	8.82	CBG-M3SLIY	\$ 49.00	CC	8.83	CBG-MESP61T3R	\$ 116.50	CC	8.81
CBG-M2BMKIG	\$ 37.00	CC	8.82	CBG-M3SLK	\$ 35.00	CC	8.71	CBG-MESP61T4R	\$ 116.50	CC	8.81
CBG-M2BMKIL	\$ 37.00	CC	8.82	CBG-M3SLKE	\$ 35.00	CC	8.71	CBG-MESP61F1R	\$ 81.50	CC	8.81
CBG-M2BMKIR	\$ 37.00	CC	8.82	CBG-M3SLKIC	\$ 49.00	CC	8.83	CBG-MESP61F6R	\$ 81.50	CC	8.81
CBG-M2BMKIY	\$ 37.00	CC	8.82	CBG-M3SLKIG	\$ 49.00	CC	8.83	CBG-MESP61F7R	\$ 81.50	CC	8.81
CBG-M2BMKR	\$ 23.00	CC	8.70	CBG-M3SLKIL	\$ 49.00	CC	8.83	CBG-MESP61F8R	\$ 81.50	CC	8.81
CBG-M2BML	\$ 23.00	CC	8.70	CBG-M3SLKIR	\$ 49.00	CC	8.83	CBG-MESP61F9R	\$ 81.50	CC	8.81
CBG-M2BMLE	\$ 23.00	CC	8.70	CBG-M3SLKIY	\$ 49.00	CC	8.83	CBG-MESP61FL1R	\$ 90.50	CC	8.81
CBG-M2BMLIC	\$ 37.00	CC	8.82	CBG-M3SLKR	\$ 35.00	CC	8.71	CBG-MESP61FL2R	\$ 96.50	CC	8.81
CBG-M2BMLIG	\$ 37.00	CC	8.82	CBG-M3SLL	\$ 35.00	CC	8.71	CBG-MESP61FL8R	\$ 90.50	CC	8.81
CBG-M2BMLIL	\$ 37.00	CC	8.82	CBG-M3SLE	\$ 35.00	CC	8.71	CBG-MESP61R	\$ 58.00	CC	8.81
CBG-M2BMLIR	\$ 37.00	CC	8.82	CBG-M3SLLIC	\$ 49.00	CC	8.83	CBG-MESP61R1R	\$ 85.50	CC	8.81
CBG-M2BMLIY	\$ 37.00	CC	8.82	CBG-M3SLLIG	\$ 49.00	CC	8.83	CBG-MESP61R2R	\$ 85.50	CC	8.81
CBG-M2BMLR	\$ 23.00	CC	8.70	CBG-M3SLLIL	\$ 49.00	CC	8.83	CBG-MESP61T5R	\$ 116.50	CC	8.81
CBG-M2BSK	\$ 35.00	CC	8.70	CBG-M3SLLIR	\$ 49.00	CC	8.83	CBG-MESP61T6R	\$ 116.50	CC	8.81
CBG-M2BSKE	\$ 35.00	CC	8.70	CBG-M3SLLIY	\$ 49.00	CC	8.83	CBG-MESP61T7R	\$ 116.50	CC	8.81
CBG-M2BSKIC	\$ 49.00	CC	8.82	CBG-M3SLLR	\$ 35.00	CC	8.71	CBG-MESP61T8R	\$ 116.50	CC	8.81
CBG-M2BSKIG	\$ 49.00	CC	8.82	CBG-M3SLR	\$ 35.00	CC	8.71	CBG-MESP61TL5R	\$ 125.50	CC	8.81
CBG-M2BSKIL	\$ 49.00	CC	8.82	CBG-M3SRK	\$ 35.00	CC	8.71	CBG-MESP61TL6R	\$ 125.50	CC	8.81
CBG-M2BSKIR	\$ 49.00	CC	8.82	CBG-M3SRKE	\$ 35.00	CC	8.71	CBG-MESP61TL7R	\$ 125.50	CC	8.81
CBG-M2BSKIY	\$ 49.00	CC	8.82	CBG-M3SRKIC	\$ 49.00	CC	8.83	CBG-MESP61TL8R	\$ 125.50	CC	8.81
CBG-M2BSKR	\$ 35.00	CC	8.70	CBG-M3SRKIG	\$ 49.00	CC	8.83	CBG-MESP6R	\$ 58.00	CC	8.67
CBG-M2BSL	\$ 35.00	CC	8.70	CBG-M3SRKIL	\$ 49.00	CC	8.83	CBG-MEST4IF1R	\$ 69.50	CC	8.78
CBG-M2BSLE	\$ 35.00	CC	8.70	CBG-M3SRKIR	\$ 49.00	CC	8.83	CBG-MEST4IF6R	\$ 69.50	CC	8.78

CBG-MEST4IF7R – CBG-MPPIR1*

Alphanumeric

0

Catalog number	List price	Discount schedule	Page number	Catalog number	List price	Discount schedule	Page number	Catalog number	List price	Discount schedule	Page number
CBG-MEST4IF7R	\$ 69.50	CC	8.78	CBG-MLFPT9*	\$ 69.50	CC	8.85	CBG-MPM40IR1*	\$ 71.50	CC	8.76
CBG-MEST4IF8R	\$ 69.50	CC	8.78	CBG-MLFPTL1*	\$ 78.50	CC	8.85	CBG-MPM40IR2*	\$ 71.50	CC	8.76
CBG-MEST4IF9R	\$ 69.50	CC	8.78	CBG-MLFPTL2*	\$ 84.50	CC	8.85	CBG-MPM40IT1*	\$ 102.50	CC	8.76
CBG-MEST4IFL1R	\$ 78.50	CC	8.78	CBG-MLFPTL8*	\$ 78.50	CC	8.85	CBG-MPM40IT2*	\$ 102.50	CC	8.76
CBG-MEST4IFL2R	\$ 84.50	CC	8.78	CBG-MLPT*	\$ 46.00	CC	8.85	CBG-MPM40IT3*	\$ 102.50	CC	8.76
CBG-MEST4IFL8R	\$ 78.50	CC	8.78	CBG-MLR1*	\$ 55.50	CC	8.86	CBG-MPM40IT4*	\$ 102.50	CC	8.76
CBG-MEST4IR	\$ 46.00	CC	8.78	CBG-MLR2*	\$ 55.50	CC	8.86	CBG-MPM40ITL3*	\$ 111.50	CC	8.76
CBG-MEST4IR1R	\$ 73.50	CC	8.78	CBG-MLRPT1*	\$ 73.50	CC	8.85	CBG-MPM40ITL4*	\$ 111.50	CC	8.76
CBG-MEST4IR2R	\$ 73.50	CC	8.78	CBG-MLRPT2*	\$ 73.50	CC	8.85	CBG-MPM40R	\$ 35.00	CC	8.66
CBG-MEST4IT1R	\$ 104.50	CC	8.78	CBG-MLT1*	\$ 69.00	CC	8.86	CBG-MPM40Y	\$ 35.00	CC	8.66
CBG-MEST4IT2R	\$ 104.50	CC	8.78	CBG-MLT2*	\$ 69.00	CC	8.86	CBG-MPM6B	\$ 39.00	CC	8.66
CBG-MEST4IT3R	\$ 104.50	CC	8.78	CBG-MLT3	\$ 69.00	CC	8.86	CBG-MPM6I*	\$ 48.00	CC	8.77
CBG-MEST4IT4R	\$ 104.50	CC	8.78	CBG-MLT4*	\$ 69.00	CC	8.86	CBG-MPM6IF1*	\$ 71.50	CC	8.77
CBG-MEST4IT5R	\$ 104.50	CC	8.78	CBG-MLTL3*	\$ 78.00	CC	8.86	CBG-MPM6IF6*	\$ 71.50	CC	8.77
CBG-MEST4IT6R	\$ 104.50	CC	8.78	CBG-MLTL4*	\$ 78.00	CC	8.86	CBG-MPM6IF7*	\$ 71.50	CC	8.77
CBG-MEST4IT7R	\$ 104.50	CC	8.78	CBG-MLTPLT3*	\$ 116.00	CC	8.85	CBG-MPM6IF8*	\$ 71.50	CC	8.77
CBG-MEST4IT8R	\$ 104.50	CC	8.78	CBG-MLTPLT4*	\$ 116.00	CC	8.85	CBG-MPM6IF9*	\$ 71.50	CC	8.77
CBG-MEST4ITL5R	\$ 113.50	CC	8.78	CBG-MLTPT1*	\$ 107.00	CC	8.85	CBG-MPM6IFL1*	\$ 80.50	CC	8.77
CBG-MEST4ITL6R	\$ 113.50	CC	8.78	CBG-MLTPT2*	\$ 107.00	CC	8.85	CBG-MPM6IFL2*	\$ 86.50	CC	8.77
CBG-MEST4ITL7R	\$ 113.50	CC	8.78	CBG-MLTPT3*	\$ 107.00	CC	8.85	CBG-MPM6IFL8*	\$ 80.50	CC	8.77
CBG-MEST4ITL8R	\$ 113.50	CC	8.78	CBG-MLTPT4*	\$ 107.00	CC	8.85	CBG-MPM6IR1*	\$ 75.50	CC	8.77
CBG-MEST4R	\$ 46.00	CC	8.67	CBG-MPB	\$ 17.00	CC	8.64	CBG-MPM6IR2*	\$ 75.50	CC	8.77
CBG-MEST6IF1R	\$ 81.50	CC	8.80	CBG-MPC	\$ 17.00	CC	8.64	CBG-MPM6IT1*	\$ 106.50	CC	8.77
CBG-MEST6IF6R	\$ 81.50	CC	8.80	CBG-MPEB	\$ 17.00	CC	8.64	CBG-MPM6IT2*	\$ 106.50	CC	8.77
CBG-MEST6IF7R	\$ 81.50	CC	8.80	CBG-MPEC	\$ 17.00	CC	8.64	CBG-MPM6IT3*	\$ 106.50	CC	8.77
CBG-MEST6IF8R	\$ 81.50	CC	8.80	CBG-MPEG	\$ 17.00	CC	8.64	CBG-MPM6IT4*	\$ 106.50	CC	8.77
CBG-MEST6IF9R	\$ 81.50	CC	8.80	CBG-MPEL	\$ 17.00	CC	8.64	CBG-MPM6ITL3*	\$ 115.50	CC	8.77
CBG-MEST6IFL1R	\$ 90.50	CC	8.80	CBG-MPER	\$ 17.00	CC	8.64	CBG-MPM6ITL4*	\$ 115.50	CC	8.77
CBG-MEST6IFL2R	\$ 96.50	CC	8.80	CBG-MPEW	\$ 17.00	CC	8.64	CBG-MPM6R	\$ 39.00	CC	8.66
CBG-MEST6IFL8R	\$ 90.50	CC	8.80	CBG-MPEY	\$ 17.00	CC	8.64	CBG-MPM6Y	\$ 39.00	CC	8.66
CBG-MEST6IR	\$ 58.00	CC	8.80	CBG-MPG	\$ 17.00	CC	8.64	CBG-MPMK40B	\$ 63.00	CC	8.66
CBG-MEST6IR1R	\$ 85.50	CC	8.80	CBG-MPI*	\$ 17.00	CC	8.74	CBG-MPMK40R	\$ 63.00	CC	8.66
CBG-MEST6IR2R	\$ 85.50	CC	8.80	CBG-MPIF1*	\$ 40.50	CC	8.74	CBG-MPMP3B	\$ 49.00	CC	8.66
CBG-MEST6IT1R	\$ 116.50	CC	8.80	CBG-MPIF6*	\$ 40.50	CC	8.74	CBG-MPMP3R	\$ 49.00	CC	8.66
CBG-MEST6IT2R	\$ 116.50	CC	8.80	CBG-MPIF7*	\$ 40.50	CC	8.74	CBG-MPMP40B	\$ 53.00	CC	8.66
CBG-MEST6IT3R	\$ 116.50	CC	8.80	CBG-MPIF8*	\$ 40.50	CC	8.74	CBG-MPMP40R	\$ 53.00	CC	8.66
CBG-MEST6IT4R	\$ 116.50	CC	8.80	CBG-MPIF9*	\$ 40.50	CC	8.74	CBG-MPMT3B	\$ 49.00	CC	8.66
CBG-MEST6IT5R	\$ 116.50	CC	8.80	CBG-MPIFL1*	\$ 49.50	CC	8.74	CBG-MPMT3R	\$ 49.00	CC	8.66
CBG-MEST6IT6R	\$ 116.50	CC	8.80	CBG-MPIFL2*	\$ 55.50	CC	8.74	CBG-MPMT40B	\$ 53.00	CC	8.66
CBG-MEST6IT7R	\$ 116.50	CC	8.80	CBG-MPIFL8*	\$ 49.50	CC	8.74	CBG-MPMT40R	\$ 53.00	CC	8.66
CBG-MEST6IT8R	\$ 116.50	CC	8.80	CBG-MPIR2*	\$ 44.50	CC	8.74	CBG-MPPB	\$ 34.20	CC	8.65
CBG-MEST6ITL5R	\$ 125.50	CC	8.80	CBG-MPIT1*	\$ 75.50	CC	8.74	CBG-MPPC	\$ 34.20	CC	8.65
CBG-MEST6ITL6R	\$ 125.50	CC	8.80	CBG-MPIT2*	\$ 75.50	CC	8.74	CBG-MPPEB	\$ 34.20	CC	8.65
CBG-MEST6ITL7R	\$ 125.50	CC	8.80	CBG-MPIT3*	\$ 75.50	CC	8.74	CBG-MPPEC	\$ 34.20	CC	8.65
CBG-MEST6ITL8R	\$ 125.50	CC	8.80	CBG-MPIT4*	\$ 75.50	CC	8.74	CBG-MPPEG	\$ 34.20	CC	8.65
CBG-MEST6R	\$ 58.00	CC	8.67	CBG-MPITL3*	\$ 84.50	CC	8.74	CBG-MPPEL	\$ 34.20	CC	8.65
CBG-MKPIR1*	\$ 44.50	CC	8.74	CBG-MPITL4*	\$ 84.50	CC	8.74	CBG-MPPER	\$ 34.20	CC	8.65
CBG-MLF*	\$ 28.00	CC	8.86	CBG-MPKM1	\$ 55.00	CC	8.68	CBG-MPPEW	\$ 34.20	CC	8.65
CBG-MLF1*	\$ 51.50	CC	8.86	CBG-MPKM2	\$ 55.00	CC	8.68	CBG-MPPEY	\$ 34.20	CC	8.65
CBG-MLF6*	\$ 51.50	CC	8.86	CBG-MPL	\$ 17.00	CC	8.64	CBG-MPPG	\$ 34.20	CC	8.65
CBG-MLF7*	\$ 51.50	CC	8.86	CBG-MPM40B	\$ 35.00	CC	8.66	CBG-MPPI*	\$ 34.20	CC	8.75
CBG-MLF8*	\$ 51.50	CC	8.86	CBG-MPM40I*	\$ 44.40	CC	8.76	CBG-MPPIF1*	\$ 57.70	CC	8.75
CBG-MLF9*	\$ 51.50	CC	8.86	CBG-MPM40IF1*	\$ 67.50	CC	8.76	CBG-MPPIF6*	\$ 57.70	CC	8.75
CBG-MLFL1*	\$ 60.50	CC	8.86	CBG-MPM40IF6*	\$ 67.50	CC	8.76	CBG-MPPIF7*	\$ 57.70	CC	8.75
CBG-MLFL2*	\$ 66.50	CC	8.86	CBG-MPM40IF7*	\$ 67.50	CC	8.76	CBG-MPPIF8*	\$ 57.70	CC	8.75
CBG-MLFL8*	\$ 60.50	CC	8.86	CBG-MPM40IF8*	\$ 67.50	CC	8.76	CBG-MPPIF9*	\$ 57.70	CC	8.75
CBG-MLFPT1*	\$ 69.50	CC	8.85	CBG-MPM40IF9*	\$ 67.50	CC	8.76	CBG-MPPIFL1*	\$ 66.70	CC	8.75
CBG-MLFPT6*	\$ 69.50	CC	8.85	CBG-MPM40IFL1*	\$ 76.50	CC	8.76	CBG-MPPIFL2*	\$ 72.70	CC	8.75
CBG-MLFPT7*	\$ 69.50	CC	8.85	CBG-MPM40IFL2*	\$ 82.50	CC	8.76	CBG-MPPIFL8*	\$ 66.70	CC	8.75
CBG-MLFPT8*	\$ 69.50	CC	8.85	CBG-MPM40IFL8*	\$ 76.50	CC	8.76	CBG-MPPIR1*	\$ 61.70	CC	8.75

CBG-MPPIR2* – CBK-2P4*

Catalog number	List price	Discount schedule	Page number	Catalog number	List price	Discount schedule	Page number	Catalog number	List price	Discount schedule	Page number
CBG-MPPIR2*	\$ 61.70	CC	8.75	CBG-NPE29	\$ 1.80	CC	8.92	CBK-2BMKIL	\$ 19.00	CA	8.36
CBG-MPPIT1*	\$ 92.70	CC	8.75	CBG-NPE29-01	\$ 6.50	CC	8.93	CBK-2BMKIR	\$ 19.00	CA	8.36
CBG-MPPIT2*	\$ 92.70	CC	8.75	CBG-NPE29-02	\$ 6.50	CC	8.93	CBK-2BMKIY	\$ 19.00	CA	8.36
CBG-MPPIT3*	\$ 92.70	CC	8.75	CBG-NPE29-03	\$ 6.50	CC	8.93	CBK-2BMKR	\$ 13.00	CA	8.21
CBG-MPPIT4*	\$ 92.70	CC	8.75	CBG-NPE29-04	\$ 6.50	CC	8.93	CBK-2BML	\$ 13.00	CA	8.21
CBG-MPPITL3*	\$ 101.70	CC	8.75	CBG-NPE29-05	\$ 6.50	CC	8.93	CBK-2BMLE	\$ 13.00	CA	8.21
CBG-MPPITL4*	\$ 101.70	CC	8.75	CBG-NPE3	\$ 1.80	CC	8.92	CBK-2BMLIC	\$ 19.00	CA	8.36
CBG-MPPL	\$ 34.20	CC	8.65	CBG-NPE30	\$ 6.00	CC	8.92	CBK-2BMLIG	\$ 19.00	CA	8.36
CBG-MPPR	\$ 34.20	CC	8.65	CBG-NPE31	\$ 1.80	CC	8.92	CBK-2BMLIL	\$ 19.00	CA	8.36
CBG-MPPW	\$ 34.20	CC	8.65	CBG-NPE32	\$ 1.80	CC	8.92	CBK-2BMLIR	\$ 19.00	CA	8.36
CBG-MPPY	\$ 34.20	CC	8.65	CBG-NPE32AC	\$ 1.80	CC	8.92	CBK-2BMLIY	\$ 19.00	CA	8.36
CBG-MPR	\$ 17.00	CC	8.64	CBG-NPE4	\$ 1.80	CC	8.92	CBK-2BMLR	\$ 13.00	CA	8.21
CBG-MPW	\$ 17.00	CC	8.64	CBG-NPE5	\$ 1.80	CC	8.92	CBK-2BSK	\$ 16.00	CA	8.21
CBG-MPY	\$ 17.00	CC	8.64	CBG-NPE6	\$ 1.80	CC	8.92	CBK-2BSKE	\$ 16.00	CA	8.21
CBG-MRB	\$ 18.00	CC	8.73	CBG-NPE7	\$ 1.80	CC	8.92	CBK-2BSKIC	\$ 28.00	CA	8.36
CBG-MS2KM1	\$ 60.00	CC	8.72	CBG-NPE8	\$ 1.80	CC	8.92	CBK-2BSKIG	\$ 28.00	CA	8.36
CBG-MS2KM4	\$ 60.00	CC	8.72	CBG-NPE9	\$ 1.80	CC	8.92	CBK-2BSKIL	\$ 28.00	CA	8.36
CBG-MS2KS1	\$ 60.00	CC	8.72	CBG-PKM1	\$ 55.00	CC	8.68	CBK-2BSKIR	\$ 28.00	CA	8.36
CBG-MS3KM2	\$ 72.00	CC	8.72	CBG-PKM2	\$ 55.00	CC	8.68	CBK-2BSKIY	\$ 28.00	CA	8.36
CBG-MS3KM4	\$ 72.00	CC	8.72	CBG-PKM3	\$ 55.00	CC	8.68	CBK-2BSKR	\$ 16.00	CA	8.21
CBG-MS3KS2	\$ 72.00	CC	8.72	CBG-PM3A	\$ 10.00	CC	8.73	CBK-2BSL	\$ 16.00	CA	8.21
CBG-MS3KSR1	\$ 72.00	CC	8.72	CBG-PMP3B	\$ 49.00	CC	8.66	CBK-2BSLE	\$ 16.00	CA	8.21
CBG-MSP10K	\$ 125.00	CC	8.73	CBG-PMP3R	\$ 49.00	CC	8.66	CBK-2BSLIC	\$ 28.00	CA	8.36
CBG-MSP10K4XP	\$ 110.00	CC	8.73	CBG-PMP40B	\$ 53.00	CC	8.66	CBK-2BSLIG	\$ 28.00	CA	8.36
CBG-MSP5K	\$ 125.00	CC	8.73	CBG-PMP40R	\$ 53.00	CC	8.66	CBK-2BSLIL	\$ 28.00	CA	8.36
CBG-MSP5K4XP	\$ 110.00	CC	8.73	CBG-PMT3B	\$ 49.00	CC	8.66	CBK-2BSLIR	\$ 28.00	CA	8.36
CBG-MTM	\$ 31.50	CC	8.69	CBG-PMT3R	\$ 49.00	CC	8.66	CBK-2BSLIY	\$ 28.00	CA	8.36
CBG-MTM3	\$ 31.50	CC	8.69	CBG-PMT40B	\$ 53.00	CC	8.66	CBK-2BSLR	\$ 16.00	CA	8.21
CBG-MTS	\$ 31.50	CC	8.69	CBG-PMT40R	\$ 53.00	CC	8.66	CBK-2LC	\$ 2.40	CA	8.34
CBG-NPE/SP	\$ 10.00	CC	8.73	CBG-RB	\$ 18.00	CC	8.73	CBK-2LG	\$ 2.40	CA	8.34
CBG-NPE1	\$ 1.80	CC	8.92	CBG-S2KM1	\$ 60.00	CC	8.72	CBK-2LR	\$ 2.40	CA	8.34
CBG-NPE10	\$ 1.80	CC	8.92	CBG-S2KM4	\$ 60.00	CC	8.72	CBK-2LY	\$ 2.40	CA	8.34
CBG-NPE11	\$ 1.80	CC	8.92	CBG-S2KS1	\$ 60.00	CC	8.72	CBK-2P1	\$ 23.00	CA	8.18
CBG-NPE12	\$ 1.80	CC	8.92	CBG-S3KM2	\$ 72.00	CC	8.72	CBK-2P1*	\$ 31.00	CA	8.33
CBG-NPE13	\$ 1.80	CC	8.92	CBG-S3KM4	\$ 72.00	CC	8.72	CBK-2P10	\$ 23.00	CA	8.18
CBG-NPE14	\$ 1.80	CC	8.92	CBG-S3KS2	\$ 72.00	CC	8.72	CBK-2P10*	\$ 31.00	CA	8.33
CBG-NPE15	\$ 1.80	CC	8.92	CBG-S3KSR1	\$ 72.00	CC	8.72	CBK-2P11	\$ 23.00	CA	8.18
CBG-NPE16	\$ 1.80	CC	8.92	CBG-TM	\$ 31.50	CC	8.69	CBK-2P11*	\$ 31.00	CA	8.33
CBG-NPE17	\$ 1.80	CC	8.92	CBG-TM3	\$ 31.50	CC	8.69	CBK-2P12	\$ 23.00	CA	8.18
CBG-NPE18	\$ 1.80	CC	8.92	CBG-TS	\$ 31.50	CC	8.69	CBK-2P12*	\$ 31.00	CA	8.33
CBG-NPE19	\$ 1.80	CC	8.92	CBK-2AMK	\$ 13.00	CA	8.21	CBK-2P13	\$ 23.00	CA	8.18
CBG-NPE2	\$ 1.80	CC	8.92	CBK-2AMKE	\$ 13.00	CA	8.21	CBK-2P13*	\$ 31.00	CA	8.33
CBG-NPE20	\$ 1.80	CC	8.92	CBK-2AMKIC	\$ 19.00	CA	8.36	CBK-2P14	\$ 23.00	CA	8.18
CBG-NPE21	\$ 1.80	CC	8.92	CBK-2AMKIG	\$ 19.00	CA	8.36	CBK-2P14*	\$ 31.00	CA	8.33
CBG-NPE22	\$ 1.80	CC	8.92	CBK-2AMKIL	\$ 19.00	CA	8.36	CBK-2P15	\$ 23.00	CA	8.18
CBG-NPE22AC	\$ 1.80	CC	8.92	CBK-2AMKIR	\$ 19.00	CA	8.36	CBK-2P15*	\$ 31.00	CA	8.33
CBG-NPE23	\$ 1.80	CC	8.92	CBK-2AMKIY	\$ 19.00	CA	8.36	CBK-2P16	\$ 20.00	CA	8.18
CBG-NPE23AC	\$ 1.80	CC	8.92	CBK-2AMKR	\$ 13.00	CA	8.21	CBK-2P16*	\$ 28.00	CA	8.33
CBG-NPE24	\$ 1.80	CC	8.92	CBK-2AML	\$ 13.00	CA	8.21	CBK-2P17	\$ 20.00	CA	8.18
CBG-NPE24AC	\$ 1.80	CC	8.92	CBK-2AMLE	\$ 13.00	CA	8.21	CBK-2P17*	\$ 28.00	CA	8.33
CBG-NPE25	\$ 1.80	CC	8.92	CBK-2AMLIC	\$ 19.00	CA	8.36	CBK-2P18	\$ 20.00	CA	8.18
CBG-NPE25AC	\$ 1.80	CC	8.92	CBK-2AMLIG	\$ 19.00	CA	8.36	CBK-2P18*	\$ 28.00	CA	8.33
CBG-NPE26	\$ 1.80	CC	8.92	CBK-2AMLIL	\$ 19.00	CA	8.36	CBK-2P2	\$ 23.00	CA	8.18
CBG-NPE27	\$ 1.80	CC	8.92	CBK-2AMLIR	\$ 19.00	CA	8.36	CBK-2P2*	\$ 31.00	CA	8.33
CBG-NPE28	\$ 1.80	CC	8.92	CBK-2AMLIY	\$ 19.00	CA	8.36	CBK-2P20	\$ 20.00	CA	8.18
CBG-NPE28-01	\$ 6.50	CC	8.93	CBK-2AMLR	\$ 13.00	CA	8.21	CBK-2P20*	\$ 28.00	CA	8.33
CBG-NPE28-02	\$ 6.50	CC	8.93	CBK-2BMK	\$ 13.00	CA	8.21	CBK-2P3	\$ 23.00	CA	8.18
CBG-NPE28-03	\$ 6.50	CC	8.93	CBK-2BMKE	\$ 13.00	CA	8.21	CBK-2P3*	\$ 31.00	CA	8.33
CBG-NPE28-04	\$ 6.50	CC	8.93	CBK-2BMKIC	\$ 19.00	CA	8.36	CBK-2P4	\$ 20.00	CA	8.18
CBG-NPE28-05	\$ 6.50	CC	8.93	CBK-2BMKIG	\$ 19.00	CA	8.36	CBK-2P4*	\$ 28.00	CA	8.33

CBK-2P4UD – CBK-EST4IF1R

Alphanumeric

0

Catalog number	List price	Discount schedule	Page number	Catalog number	List price	Discount schedule	Page number	Catalog number	List price	Discount schedule	Page number
CBK-2P4UD	\$ 23.00	CA	8.18	CBK-3SRK	\$ 16.00	CA	8.22	CBK-CS	\$ 2.00	CAE	8.52
CBK-2P4UD*	\$ 31.00	CA	8.33	CBK-3SRKE	\$ 16.00	CA	8.22	CBK-EP1	\$ 28.00	CAE	8.52
CBK-2P5	\$ 20.00	CA	8.18	CBK-3SRKIC	\$ 28.00	CA	8.37	CBK-EP2	\$ 32.00	CAE	8.52
CBK-2P5*	\$ 28.00	CA	8.33	CBK-3SRKIG	\$ 28.00	CA	8.37	CBK-EP3	\$ 36.00	CAE	8.52
CBK-2P6	\$ 23.00	CA	8.18	CBK-3SRKIL	\$ 28.00	CA	8.37	CBK-EP4	\$ 44.00	CAE	8.52
CBK-2P6*	\$ 31.00	CA	8.33	CBK-3SRKIR	\$ 28.00	CA	8.37	CBK-EP6	\$ 52.00	CAE	8.52
CBK-2P7	\$ 23.00	CA	8.18	CBK-3SRKIY	\$ 28.00	CA	8.37	CBK-EPY	\$ 28.00	CAE	8.52
CBK-2P7*	\$ 31.00	CA	8.33	CBK-3SRKR	\$ 16.00	CA	8.22	CBK-ESAP	\$ 6.00	CAE	8.52
CBK-2P8	\$ 23.00	CA	8.18	CBK-3SRL	\$ 16.00	CA	8.22	CBK-ESCH	\$ 2.00	CA	8.17
CBK-2P8*	\$ 31.00	CA	8.33	CBK-3SRLE	\$ 16.00	CA	8.22	CBK-ESK3A	\$ 8.00	CA	8.49
CBK-2P9	\$ 23.00	CA	8.18	CBK-3SRLIC	\$ 28.00	CA	8.37	CBK-ESM3A	\$ 10.00	CA	8.49
CBK-2P9*	\$ 31.00	CA	8.33	CBK-3SRLIG	\$ 28.00	CA	8.37	CBK-ESP4IF1R	\$ 59.50	CA	8.31
CBK-3MK	\$ 13.00	CA	8.22	CBK-3SRLIL	\$ 28.00	CA	8.37	CBK-ESP4IF6R	\$ 59.50	CA	8.31
CBK-3MKE	\$ 13.00	CA	8.22	CBK-3SRLIR	\$ 28.00	CA	8.37	CBK-ESP4IF7R	\$ 59.50	CA	8.31
CBK-3MKIC	\$ 19.00	CA	8.37	CBK-3SRLIY	\$ 28.00	CA	8.37	CBK-ESP4IF8R	\$ 59.50	CA	8.31
CBK-3MKIG	\$ 19.00	CA	8.37	CBK-3SRLR	\$ 16.00	CA	8.22	CBK-ESP4IF9R	\$ 59.50	CA	8.31
CBK-3MKIL	\$ 19.00	CA	8.37	CBK-AR	\$ 2.25	CA	8.23	CBK-ESP4IFL1R	\$ 68.50	CA	8.31
CBK-3MKIR	\$ 19.00	CA	8.37	CBK-BM3B	\$ 2.00	CA	8.48	CBK-ESP4IFL2R	\$ 74.50	CA	8.31
CBK-3MKIY	\$ 19.00	CA	8.37	CBK-BM3BA	\$ 2.00	CA	8.48	CBK-ESP4IFL8R	\$ 68.50	CA	8.31
CBK-3MKR	\$ 13.00	CA	8.22	CBK-BM3R	\$ 2.00	CA	8.48	CBK-ESP4IR	\$ 36.00	CA	8.31
CBK-3ML	\$ 13.00	CA	8.22	CBK-BM3RA	\$ 2.00	CA	8.48	CBK-ESP4IR1R	\$ 63.50	CA	8.31
CBK-3MLE	\$ 13.00	CA	8.22	CBK-BM40B	\$ 2.00	CA	8.48	CBK-ESP4IR2R	\$ 63.50	CA	8.31
CBK-3MLIC	\$ 19.00	CA	8.37	CBK-BM40BA	\$ 2.00	CA	8.48	CBK-ESP4IT1R	\$ 94.50	CA	8.31
CBK-3MLIG	\$ 19.00	CA	8.37	CBK-BM40BO	\$ 2.00	CA	8.48	CBK-ESP4IT2R	\$ 94.50	CA	8.31
CBK-3MLIL	\$ 19.00	CA	8.37	CBK-BM40R	\$ 2.00	CA	8.48	CBK-ESP4IT3R	\$ 94.50	CA	8.31
CBK-3MLIR	\$ 19.00	CA	8.37	CBK-BM40RA	\$ 2.00	CA	8.48	CBK-ESP4IT4R	\$ 94.50	CA	8.31
CBK-3MLIY	\$ 19.00	CA	8.37	CBK-BM40RO	\$ 2.00	CA	8.48	CBK-ESP4IT5R	\$ 94.50	CA	8.31
CBK-3MLR	\$ 13.00	CA	8.22	CBK-BM4IG	\$ 4.00	CA	8.48	CBK-ESP4IT6R	\$ 94.50	CA	8.31
CBK-3SK	\$ 16.00	CA	8.22	CBK-BM4IR	\$ 4.00	CA	8.48	CBK-ESP4IT7R	\$ 94.50	CA	8.31
CBK-3SKE	\$ 16.00	CA	8.22	CBK-BM4IY	\$ 4.00	CA	8.48	CBK-ESP4IT8R	\$ 94.50	CA	8.31
CBK-3SKIC	\$ 28.00	CA	8.37	CBK-BM60B	\$ 6.00	CA	8.48	CBK-ESP4ITL1R	\$ 103.50	CA	8.31
CBK-3SKIG	\$ 28.00	CA	8.37	CBK-BM60R	\$ 6.00	CA	8.48	CBK-ESP4ITL2R	\$ 103.50	CA	8.31
CBK-3SKIL	\$ 28.00	CA	8.37	CBK-BM60Y	\$ 6.00	CA	8.48	CBK-ESP4ITL3R	\$ 103.50	CA	8.31
CBK-3SKIR	\$ 28.00	CA	8.37	CBK-BM6IG	\$ 8.00	CA	8.48	CBK-ESP4ITL4R	\$ 103.50	CA	8.31
CBK-3SKIY	\$ 28.00	CA	8.37	CBK-BM6IR	\$ 8.00	CA	8.48	CBK-ESP4R	\$ 36.00	CA	8.17
CBK-3SKR	\$ 16.00	CA	8.22	CBK-BM6IY	\$ 8.00	CA	8.48	CBK-ESP6IF1R	\$ 71.50	CA	8.32
CBK-3SL	\$ 16.00	CA	8.22	CBK-BR40Y	\$ 2.00	CA	8.48	CBK-ESP6IF6R	\$ 71.50	CA	8.32
CBK-3SLE	\$ 16.00	CA	8.22	CBK-BZ1	\$ 75.00	CA	8.23	CBK-ESP6IF7R	\$ 71.50	CA	8.32
CBK-3SLIC	\$ 28.00	CA	8.37	CBK-BZ2	\$ 75.00	CA	8.23	CBK-ESP6IF8R	\$ 71.50	CA	8.32
CBK-3SLIG	\$ 28.00	CA	8.37	CBK-BZ8	\$ 75.00	CA	8.23	CBK-ESP6IF9R	\$ 71.50	CA	8.32
CBK-3SLIL	\$ 28.00	CA	8.37	CBK-BZL	\$ 2.00	CA	8.50	CBK-ESP6IFL1R	\$ 80.50	CA	8.32
CBK-3SLIR	\$ 28.00	CA	8.37	CBK-BZP1	\$ 85.00	CA	8.23	CBK-ESP6IFL2R	\$ 86.50	CA	8.32
CBK-3SLIY	\$ 28.00	CA	8.37	CBK-BZP2	\$ 85.00	CA	8.23	CBK-ESP6IFL8R	\$ 80.50	CA	8.32
CBK-3SLK	\$ 16.00	CA	8.22	CBK-BZP8	\$ 85.00	CA	8.23	CBK-ESP6IR	\$ 48.00	CA	8.32
CBK-3SLKE	\$ 16.00	CA	8.22	CBK-CB01	\$ 8.00	CA	8.40	CBK-ESP6IR1R	\$ 75.50	CA	8.32
CBK-3SLKIC	\$ 28.00	CA	8.37	CBK-CB01FP	\$ 11.00	CA	8.40	CBK-ESP6IR2R	\$ 75.50	CA	8.32
CBK-3SLKIG	\$ 28.00	CA	8.37	CBK-CB01G	\$ 16.00	CA	8.40	CBK-ESP6IT1R	\$ 106.50	CA	8.32
CBK-3SLKIL	\$ 28.00	CA	8.37	CBK-CB01G	\$ 8.00	CA	8.40	CBK-ESP6IT2R	\$ 106.50	CA	8.32
CBK-3SLKIR	\$ 28.00	CA	8.37	CBK-CB10FP	\$ 11.00	CA	8.40	CBK-ESP6IT3R	\$ 106.50	CA	8.32
CBK-3SLKIY	\$ 28.00	CA	8.37	CBK-CB10G	\$ 16.00	CA	8.40	CBK-ESP6IT4R	\$ 106.50	CA	8.32
CBK-3SLKR	\$ 16.00	CA	8.22	CBK-CBD	\$ 14.00	CA	8.42	CBK-ESP6IT5R	\$ 106.50	CA	8.32
CBK-3SLL	\$ 16.00	CA	8.22	CBK-CBR01	\$ 8.00	CA	8.41	CBK-ESP6IT6R	\$ 106.50	CA	8.32
CBK-3SLE	\$ 16.00	CA	8.22	CBK-CBR01FP	\$ 11.00	CA	8.41	CBK-ESP6IT7R	\$ 106.50	CA	8.32
CBK-3SLLIC	\$ 28.00	CA	8.37	CBK-CBR01G	\$ 16.00	CA	8.41	CBK-ESP6IT8R	\$ 106.50	CA	8.32
CBK-3SLLIG	\$ 28.00	CA	8.37	CBK-CBR10	\$ 8.00	CA	8.41	CBK-ESP6ITL1R	\$ 115.50	CA	8.32
CBK-3SLLIL	\$ 28.00	CA	8.37	CBK-CBR10FP	\$ 11.00	CA	8.41	CBK-ESP6ITL2R	\$ 115.50	CA	8.32
CBK-3SLLIR	\$ 28.00	CA	8.37	CBK-CBR10G	\$ 16.00	CA	8.41	CBK-ESP6ITL3R	\$ 115.50	CA	8.32
CBK-3SLLIY	\$ 28.00	CA	8.37	CBK-CH	\$ 2.00	CA	8.40	CBK-ESP6ITL4R	\$ 115.50	CA	8.32
CBK-3SLLR	\$ 16.00	CA	8.22	CBK-CMR	\$ 2.50	CA	8.49	CBK-ESP6R	\$ 48.00	CA	8.17
CBK-3SLR	\$ 16.00	CA	8.22	CBK-CMRS	\$ 2.50	CA	8.49	CBK-EST4IF1R	\$ 59.50	CA	8.31

CBK-EST4IF6R – CBK-KC69P

Catalog number	List price	Discount schedule	Page number	Catalog number	List price	Discount schedule	Page number	Catalog number	List price	Discount schedule	Page number
CBK-EST4IF6R	\$ 59.50	CA	8.31	CBK-KBEIW	\$ 1.50	CA	8.48	CBK-KC34	\$ 0.90	CA	8.43
CBK-EST4IF7R	\$ 59.50	CA	8.31	CBK-KBEIY	\$ 1.50	CA	8.48	CBK-KC35	\$ 0.90	CA	8.43
CBK-EST4IF8R	\$ 59.50	CA	8.31	CBK-KBEL	\$ 1.50	CA	8.48	CBK-KC35E	\$ 0.90	CA	8.43
CBK-EST4IF9R	\$ 59.50	CA	8.31	CBK-KBER	\$ 1.50	CA	8.48	CBK-KC36	\$ 0.90	CA	8.43
CBK-EST4IFL1R	\$ 68.50	CA	8.31	CBK-KBEW	\$ 1.50	CA	8.48	CBK-KC37	\$ 0.90	CA	8.43
CBK-EST4IFL2R	\$ 74.50	CA	8.31	CBK-KBEY	\$ 1.50	CA	8.48	CBK-KC38	\$ 0.90	CA	8.43
CBK-EST4IFL8R	\$ 68.50	CA	8.31	CBK-KBG	\$ 1.50	CA	8.48	CBK-KC39	\$ 0.90	CA	8.43
CBK-EST4IR	\$ 36.00	CA	8.31	CBK-KBIC	\$ 1.50	CA	8.48	CBK-KC39E	\$ 0.90	CA	8.43
CBK-EST4IR1R	\$ 63.50	CA	8.31	CBK-KBIG	\$ 1.50	CA	8.48	CBK-KC4	\$ 0.90	CA	8.44
CBK-EST4IR2R	\$ 63.50	CA	8.31	CBK-KBIL	\$ 1.50	CA	8.48	CBK-KC40	\$ 0.90	CA	8.43
CBK-EST4IT1R	\$ 94.50	CA	8.31	CBK-KBIR	\$ 1.50	CA	8.48	CBK-KC41	\$ 0.90	CA	8.43
CBK-EST4IT2R	\$ 94.50	CA	8.31	CBK-KBIW	\$ 1.50	CA	8.48	CBK-KC41E	\$ 0.90	CA	8.43
CBK-EST4IT3R	\$ 94.50	CA	8.31	CBK-KBIY	\$ 1.50	CA	8.48	CBK-KC42	\$ 0.90	CA	8.43
CBK-EST4IT4R	\$ 94.50	CA	8.31	CBK-KBL	\$ 1.50	CA	8.48	CBK-KC43	\$ 0.90	CA	8.43
CBK-EST4IT5R	\$ 94.50	CA	8.31	CBK-KBR	\$ 1.50	CA	8.48	CBK-KC43E	\$ 0.90	CA	8.43
CBK-EST4IT6R	\$ 94.50	CA	8.31	CBK-KBW	\$ 1.50	CA	8.48	CBK-KC44	\$ 0.90	CA	8.43
CBK-EST4IT7R	\$ 94.50	CA	8.31	CBK-KBY	\$ 1.50	CA	8.48	CBK-KC45	\$ 0.90	CA	8.43
CBK-EST4IT8R	\$ 94.50	CA	8.31	CBK-KC1	\$ 0.90	CA	8.44	CBK-KC45E	\$ 0.90	CA	8.43
CBK-EST4ITL1R	\$ 103.50	CA	8.31	CBK-KC10	\$ 0.90	CA	8.44	CBK-KC46	\$ 0.90	CA	8.43
CBK-EST4ITL2R	\$ 103.50	CA	8.31	CBK-KC11	\$ 0.90	CA	8.44	CBK-KC47	\$ 0.90	CA	8.43
CBK-EST4ITL3R	\$ 103.50	CA	8.31	CBK-KC12	\$ 0.90	CA	8.44	CBK-KC47E	\$ 0.90	CA	8.43
CBK-EST4ITL4R	\$ 103.50	CA	8.31	CBK-KC13	\$ 0.90	CA	8.43	CBK-KC48	\$ 0.90	CA	8.43
CBK-EST4R	\$ 36.00	CA	8.17	CBK-KC13E	\$ 0.90	CA	8.43	CBK-KC49	\$ 0.90	CA	8.43
CBK-EST6IF1R	\$ 71.50	CA	8.32	CBK-KC13P	\$ 0.90	CA	8.43	CBK-KC49E	\$ 0.90	CA	8.43
CBK-EST6IF6R	\$ 71.50	CA	8.32	CBK-KC14	\$ 0.90	CA	8.43	CBK-KC4E	\$ 0.90	CA	8.44
CBK-EST6IF7R	\$ 71.50	CA	8.32	CBK-KC14E	\$ 0.90	CA	8.43	CBK-KC5	\$ 0.90	CA	8.44
CBK-EST6IF8R	\$ 71.50	CA	8.32	CBK-KC14P	\$ 0.90	CA	8.43	CBK-KC50	\$ 0.90	CA	8.43
CBK-EST6IF9R	\$ 71.50	CA	8.32	CBK-KC15	\$ 0.90	CA	8.44	CBK-KC51	\$ 0.90	CA	8.43
CBK-EST6IFL1R	\$ 80.50	CA	8.32	CBK-KC15E	\$ 0.90	CA	8.44	CBK-KC51E	\$ 0.90	CA	8.43
CBK-EST6IFL2R	\$ 86.50	CA	8.32	CBK-KC15P	\$ 0.90	CA	8.44	CBK-KC52	\$ 0.90	CA	8.43
CBK-EST6IFL8R	\$ 80.50	CA	8.32	CBK-KC16	\$ 0.90	CA	8.44	CBK-KC53	\$ 0.90	CA	8.43
CBK-EST6IR	\$ 48.00	CA	8.32	CBK-KC17	\$ 0.90	CA	8.44	CBK-KC53E	\$ 0.90	CA	8.43
CBK-EST6IR1R	\$ 75.50	CA	8.32	CBK-KC18	\$ 0.90	CA	8.44	CBK-KC54	\$ 0.90	CA	8.43
CBK-EST6IR2R	\$ 75.50	CA	8.32	CBK-KC19	\$ 0.90	CA	8.44	CBK-KC55	\$ 0.90	CA	8.43
CBK-EST6IT1R	\$ 106.50	CA	8.32	CBK-KC2	\$ 0.90	CA	8.44	CBK-KC55E	\$ 0.90	CA	8.43
CBK-EST6IT2R	\$ 106.50	CA	8.32	CBK-KC20	\$ 0.90	CA	8.44	CBK-KC56	\$ 0.90	CA	8.43
CBK-EST6IT3R	\$ 106.50	CA	8.32	CBK-KC21	\$ 0.90	CA	8.43	CBK-KC57	\$ 0.90	CA	8.43
CBK-EST6IT4R	\$ 106.50	CA	8.32	CBK-KC21E	\$ 0.90	CA	8.43	CBK-KC57E	\$ 0.90	CA	8.43
CBK-EST6IT5R	\$ 106.50	CA	8.32	CBK-KC21P	\$ 0.90	CA	8.43	CBK-KC58	\$ 0.90	CA	8.43
CBK-EST6IT6R	\$ 106.50	CA	8.32	CBK-KC22	\$ 0.90	CA	8.43	CBK-KC59	\$ 0.90	CA	8.43
CBK-EST6IT7R	\$ 106.50	CA	8.32	CBK-KC22E	\$ 0.90	CA	8.43	CBK-KC59E	\$ 0.90	CA	8.43
CBK-EST6IT8R	\$ 106.50	CA	8.32	CBK-KC23	\$ 0.90	CA	8.43	CBK-KC6	\$ 0.90	CA	8.44
CBK-EST6ITL1R	\$ 115.50	CA	8.32	CBK-KC24	\$ 0.90	CA	8.43	CBK-KC60	\$ 0.90	CA	8.43
CBK-EST6ITL2R	\$ 115.50	CA	8.32	CBK-KC24E	\$ 0.90	CA	8.43	CBK-KC61	\$ 0.90	CA	8.43
CBK-EST6ITL3R	\$ 115.50	CA	8.32	CBK-KC24P	\$ 0.90	CA	8.43	CBK-KC61E	\$ 0.90	CA	8.43
CBK-EST6ITL4R	\$ 115.50	CA	8.32	CBK-KC25	\$ 0.90	CA	8.43	CBK-KC62	\$ 0.90	CA	8.43
CBK-EST6R	\$ 48.00	CA	8.17	CBK-KC26	\$ 0.90	CA	8.43	CBK-KC63	\$ 0.90	CA	8.43
CBK-H5	\$ 4.00	CA	8.40	CBK-KC27	\$ 0.90	CA	8.43	CBK-KC63E	\$ 0.90	CA	8.43
CBK-K3A	\$ 8.00	CA	8.49	CBK-KC27E	\$ 0.90	CA	8.43	CBK-KC64	\$ 0.90	CA	8.43
CBK-KBB	\$ 1.50	CA	8.48	CBK-KC27P	\$ 0.90	CA	8.43	CBK-KC65	\$ 0.90	CA	8.43
CBK-KBC	\$ 1.50	CA	8.48	CBK-KC28	\$ 0.90	CA	8.43	CBK-KC65E	\$ 0.90	CA	8.43
CBK-KBE	\$ 1.50	CA	8.48	CBK-KC29	\$ 0.90	CA	8.43	CBK-KC66	\$ 0.90	CA	8.43
CBK-KBEB	\$ 1.50	CA	8.48	CBK-KC2E	\$ 0.90	CA	8.44	CBK-KC67	\$ 0.90	CA	8.44
CBK-KBEC	\$ 1.50	CA	8.48	CBK-KC3	\$ 0.90	CA	8.44	CBK-KC67E	\$ 0.90	CA	8.44
CBK-KBEE	\$ 1.50	CA	8.48	CBK-KC30	\$ 0.90	CA	8.43	CBK-KC67P	\$ 0.90	CA	8.44
CBK-KBEG	\$ 1.50	CA	8.48	CBK-KC30E	\$ 0.90	CA	8.43	CBK-KC68	\$ 0.90	CA	8.44
CBK-KBEIC	\$ 1.50	CA	8.48	CBK-KC31	\$ 0.90	CA	8.43	CBK-KC68E	\$ 0.90	CA	8.44
CBK-KBEIG	\$ 1.50	CA	8.48	CBK-KC32	\$ 0.90	CA	8.43	CBK-KC68P	\$ 0.90	CA	8.44
CBK-KBEIL	\$ 1.50	CA	8.48	CBK-KC32E	\$ 0.90	CA	8.43	CBK-KC69	\$ 0.90	CA	8.44
CBK-KBEIR	\$ 1.50	CA	8.48	CBK-KC33	\$ 0.90	CA	8.43	CBK-KC69P	\$ 0.90	CA	8.44

CBK-KC7 – CBK-KPPIF6*

Alphanumeric

0

Catalog number	List price	Discount schedule	Page number	Catalog number	List price	Discount schedule	Page number	Catalog number	List price	Discount schedule	Page number
CBK-KC7	\$ 0.90	CA	8.44	CBK-KLTL1*	\$ 74.00	CA	8.39	CBK-KPM40IF8*	\$ 41.00	CA	8.29
CBK-KC70	\$ 0.90	CA	8.44	CBK-KLTL2*	\$ 74.00	CA	8.39	CBK-KPM40IF9*	\$ 41.00	CA	8.29
CBK-KC71	\$ 0.90	CA	8.44	CBK-KLTL3*	\$ 74.00	CA	8.39	CBK-KPM40IFL1*	\$ 50.00	CA	8.29
CBK-KC71E	\$ 0.90	CA	8.44	CBK-KLTL4*	\$ 74.00	CA	8.39	CBK-KPM40IFL2*	\$ 56.00	CA	8.29
CBK-KC71P	\$ 0.90	CA	8.44	CBK-KLTPN2*	\$ 46.00	CA	8.35	CBK-KPM40IFL8*	\$ 50.00	CA	8.29
CBK-KC72E	\$ 0.90	CA	8.44	CBK-KLTPPT1*	\$ 80.00	CA	8.35	CBK-KPM40IR1*	\$ 45.00	CA	8.29
CBK-KC73E	\$ 0.90	CA	8.44	CBK-KLTPPT2*	\$ 80.00	CA	8.35	CBK-KPM40IR2*	\$ 45.00	CA	8.29
CBK-KC74	\$ 0.90	CA	8.44	CBK-KLTPPT3*	\$ 80.00	CA	8.35	CBK-KPM40IT1*	\$ 76.00	CA	8.29
CBK-KC74E	\$ 0.90	CA	8.44	CBK-KLTPPT4*	\$ 80.00	CA	8.35	CBK-KPM40IT2*	\$ 76.00	CA	8.29
CBK-KC74P	\$ 0.90	CA	8.44	CBK-KLTPPT5*	\$ 80.00	CA	8.35	CBK-KPM40IT3*	\$ 76.00	CA	8.29
CBK-KC75	\$ 0.90	CA	8.44	CBK-KLTPPT6*	\$ 80.00	CA	8.35	CBK-KPM40IT4*	\$ 76.00	CA	8.29
CBK-KC75E	\$ 0.90	CA	8.44	CBK-KLTPPT7*	\$ 80.00	CA	8.35	CBK-KPM40IT5*	\$ 76.00	CA	8.29
CBK-KC75P	\$ 0.90	CA	8.44	CBK-KLTPPT8*	\$ 80.00	CA	8.35	CBK-KPM40IT6*	\$ 76.00	CA	8.29
CBK-KC76	\$ 0.90	CA	8.43	CBK-KLTPPTL1*	\$ 80.00	CA	8.35	CBK-KPM40IT7*	\$ 76.00	CA	8.29
CBK-KC77	\$ 0.90	CA	8.43	CBK-KLTPPTL2*	\$ 80.00	CA	8.35	CBK-KPM40IT8*	\$ 76.00	CA	8.29
CBK-KC78P	\$ 0.90	CA	8.43	CBK-KLTPPTL3*	\$ 80.00	CA	8.35	CBK-KPM40ITL1*	\$ 85.00	CA	8.29
CBK-KC79P	\$ 0.90	CA	8.43	CBK-KLTPPTL4*	\$ 80.00	CA	8.35	CBK-KPM40ITL2*	\$ 85.00	CA	8.29
CBK-KC8	\$ 0.90	CA	8.44	CBK-KLW	\$ 2.50	CA	8.48	CBK-KPM40ITL3*	\$ 85.00	CA	8.29
CBK-KC80	\$ 0.90	CA	8.43	CBK-KLY	\$ 2.50	CA	8.48	CBK-KPM40ITL4*	\$ 85.00	CA	8.29
CBK-KC81	\$ 0.90	CA	8.44	CBK-KNPHB	\$ 0.70	CA	8.45	CBK-KPM40R	\$ 18.00	CA	8.16
CBK-KC82	\$ 0.90	CA	8.44	CBK-KPB	\$ 8.10	CA	8.14	CBK-KPM40Y	\$ 18.00	CA	8.16
CBK-KCE9	\$ 0.90	CA	8.44	CBK-KPC	\$ 8.10	CA	8.14	CBK-KPM6B	\$ 22.00	CA	8.16
CBK-KCEG	\$ 0.90	CA	8.44	CBK-KPEB	\$ 8.10	CA	8.14	CBK-KPM6I*	\$ 21.50	CA	8.30
CBK-KCG	\$ 0.90	CA	8.44	CBK-KPEC	\$ 8.10	CA	8.14	CBK-KPM6IF1*	\$ 45.00	CA	8.30
CBK-KKNOB	\$ 15.00	CA	8.23	CBK-KPEG	\$ 8.10	CA	8.14	CBK-KPM6IF6*	\$ 45.00	CA	8.30
CBK-KLC	\$ 2.50	CA	8.48	CBK-KPEL	\$ 8.10	CA	8.14	CBK-KPM6IF7*	\$ 45.00	CA	8.30
CBK-KLF*	\$ 6.50	CA	8.39	CBK-KPER	\$ 8.10	CA	8.14	CBK-KPM6IF8*	\$ 45.00	CA	8.30
CBK-KLF1*	\$ 30.00	CA	8.39	CBK-KPEW	\$ 8.10	CA	8.14	CBK-KPM6IF9*	\$ 45.00	CA	8.30
CBK-KLF6*	\$ 30.00	CA	8.39	CBK-KPEY	\$ 8.10	CA	8.14	CBK-KPM6IFL1*	\$ 54.00	CA	8.30
CBK-KLF7*	\$ 30.00	CA	8.39	CBK-KPG	\$ 8.10	CA	8.14	CBK-KPM6IFL2*	\$ 60.00	CA	8.30
CBK-KLF8*	\$ 30.00	CA	8.39	CBK-KPI*	\$ 8.10	CA	8.25	CBK-KPM6IFL8*	\$ 54.00	CA	8.30
CBK-KLF9*	\$ 30.00	CA	8.39	CBK-KPIF1*	\$ 31.60	CA	8.25	CBK-KPM6IR1*	\$ 49.00	CA	8.30
CBK-KLFL1*	\$ 39.00	CA	8.39	CBK-KPIF6*	\$ 31.60	CA	8.25	CBK-KPM6IR2*	\$ 49.00	CA	8.30
CBK-KLFL2*	\$ 45.00	CA	8.39	CBK-KPIF7*	\$ 31.60	CA	8.25	CBK-KPM6IT1*	\$ 80.00	CA	8.30
CBK-KLFL8*	\$ 39.00	CA	8.39	CBK-KPIF8*	\$ 31.60	CA	8.25	CBK-KPM6IT2*	\$ 80.00	CA	8.30
CBK-KLFN2*	\$ 34.00	CA	8.39	CBK-KPIF9*	\$ 31.60	CA	8.25	CBK-KPM6IT3*	\$ 80.00	CA	8.30
CBK-KLFPT1*	\$ 46.00	CA	8.35	CBK-KPIFL1*	\$ 40.60	CA	8.25	CBK-KPM6IT4*	\$ 80.00	CA	8.30
CBK-KLFPT6*	\$ 46.00	CA	8.35	CBK-KPIFL2*	\$ 46.60	CA	8.25	CBK-KPM6IT5*	\$ 80.00	CA	8.30
CBK-KLFPT7*	\$ 46.00	CA	8.35	CBK-KPIFL8*	\$ 40.60	CA	8.25	CBK-KPM6IT6*	\$ 80.00	CA	8.30
CBK-KLFPT8*	\$ 46.00	CA	8.35	CBK-KPIFN2*	\$ 31.60	CA	8.25	CBK-KPM6IT7*	\$ 80.00	CA	8.30
CBK-KLFPT9*	\$ 46.00	CA	8.35	CBK-KPIR1*	\$ 35.60	CA	8.25	CBK-KPM6IT8*	\$ 80.00	CA	8.30
CBK-KLFPPTL1*	\$ 55.00	CA	8.35	CBK-KPIR2*	\$ 35.60	CA	8.25	CBK-KPM6ITL1*	\$ 89.00	CA	8.30
CBK-KLFPPTL2*	\$ 61.00	CA	8.35	CBK-KPIT1*	\$ 66.60	CA	8.25	CBK-KPM6ITL2*	\$ 89.00	CA	8.30
CBK-KLFPPTL8*	\$ 55.00	CA	8.35	CBK-KPIT2*	\$ 66.60	CA	8.25	CBK-KPM6ITL3*	\$ 89.00	CA	8.30
CBK-KLGL	\$ 2.50	CA	8.48	CBK-KPIT3*	\$ 66.60	CA	8.25	CBK-KPM6ITL4*	\$ 89.00	CA	8.30
CBK-KLL	\$ 2.50	CA	8.48	CBK-KPIT4*	\$ 66.60	CA	8.25	CBK-KPM6R	\$ 22.00	CA	8.16
CBK-KLPT*	\$ 22.50	CA	8.35	CBK-KPIT5*	\$ 66.60	CA	8.25	CBK-KPM6Y	\$ 22.00	CA	8.16
CBK-KLR	\$ 2.50	CA	8.48	CBK-KPIT6*	\$ 66.60	CA	8.25	CBK-KPPB	\$ 19.30	CA	8.15
CBK-KLR1*	\$ 34.00	CA	8.39	CBK-KPIT7*	\$ 66.60	CA	8.25	CBK-KPPC	\$ 19.30	CA	8.15
CBK-KLR2*	\$ 34.00	CA	8.39	CBK-KPIT8*	\$ 66.60	CA	8.25	CBK-KPPEB	\$ 19.30	CA	8.15
CBK-KLRPT1*	\$ 54.00	CA	8.35	CBK-KPITL1*	\$ 75.60	CA	8.25	CBK-KPPEC	\$ 19.30	CA	8.15
CBK-KLRPT2*	\$ 54.00	CA	8.35	CBK-KPITL2*	\$ 75.60	CA	8.25	CBK-KPPEG	\$ 19.30	CA	8.15
CBK-KLT1*	\$ 65.00	CA	8.39	CBK-KPITL3*	\$ 75.60	CA	8.25	CBK-KPPEL	\$ 19.30	CA	8.15
CBK-KLT2*	\$ 65.00	CA	8.39	CBK-KPITL4*	\$ 75.60	CA	8.25	CBK-KPPER	\$ 19.30	CA	8.15
CBK-KLT3*	\$ 65.00	CA	8.39	CBK-KPL	\$ 8.10	CA	8.14	CBK-KPPEW	\$ 19.30	CA	8.15
CBK-KLT4*	\$ 65.00	CA	8.39	CBK-KPM40I*	\$ 17.50	CA	8.29	CBK-KPPEY	\$ 19.30	CA	8.15
CBK-KLT5*	\$ 65.00	CA	8.39	CBK-KPM40B	\$ 18.00	CA	8.16	CBK-KPPG	\$ 19.30	CA	8.15
CBK-KLT6*	\$ 65.00	CA	8.39	CBK-KPM40IF1*	\$ 41.00	CA	8.29	CBK-KPPI*	\$ 19.30	CA	8.27
CBK-KLT7*	\$ 65.00	CA	8.39	CBK-KPM40IF6*	\$ 41.00	CA	8.29	CBK-KPPIF1*	\$ 42.80	CA	8.27
CBK-KLT8*	\$ 65.00	CA	8.39	CBK-KPM40IF7*	\$ 41.00	CA	8.29	CBK-KPPIF6*	\$ 42.80	CA	8.27

CBK-KPPIF7* – CBK-M3SKIG

Catalog number	List price	Discount schedule	Page number	Catalog number	List price	Discount schedule	Page number	Catalog number	List price	Discount schedule	Page number
CBK-KPPIF7*	\$ 42.80	CA	8.27	CBK-LBD1R	\$ 15.00	CA	8.34	CBK-M2AMLE	\$ 13.00	CA	8.21
CBK-KPPIF8*	\$ 42.80	CA	8.27	CBK-LBD1W	\$ 18.00	CA	8.34	CBK-M2AMLIC	\$ 19.00	CA	8.36
CBK-KPPIF9*	\$ 42.80	CA	8.27	CBK-LBD1Y	\$ 15.00	CA	8.34	CBK-M2AMLIG	\$ 19.00	CA	8.36
CBK-KPPIFL1*	\$ 51.80	CA	8.27	CBK-LBD2G	\$ 21.00	CA	8.34	CBK-M2AMLIL	\$ 19.00	CA	8.36
CBK-KPPIFL2*	\$ 57.80	CA	8.27	CBK-LBD2L	\$ 24.00	CA	8.34	CBK-M2AMLIR	\$ 19.00	CA	8.36
CBK-KPPIFL8*	\$ 51.80	CA	8.27	CBK-LBD2R	\$ 21.00	CA	8.34	CBK-M2AMLIY	\$ 19.00	CA	8.36
CBK-KPPIFN2*	\$ 42.80	CA	8.27	CBK-LBD2W	\$ 24.00	CA	8.34	CBK-M2AMLR	\$ 13.00	CA	8.21
CBK-KPPIR1*	\$ 47.30	CA	8.27	CBK-LBD2Y	\$ 21.00	CA	8.34	CBK-M2BMK	\$ 13.00	CA	8.21
CBK-KPPIR2*	\$ 47.30	CA	8.27	CBK-LBD48G	\$ 21.00	CA	8.34	CBK-M2BMKE	\$ 13.00	CA	8.21
CBK-KPPIR1*	\$ 78.30	CA	8.27	CBK-LBD48L	\$ 21.00	CA	8.34	CBK-M2BMKIC	\$ 19.00	CA	8.36
CBK-KPPIT2*	\$ 78.30	CA	8.27	CBK-LBD48R	\$ 21.00	CA	8.34	CBK-M2BMKIG	\$ 19.00	CA	8.36
CBK-KPPIT3	\$ 78.30	CA	8.27	CBK-LBD48W	\$ 21.00	CA	8.34	CBK-M2BMKIL	\$ 19.00	CA	8.36
CBK-KPPIT4*	\$ 78.30	CA	8.27	CBK-LBD48Y	\$ 21.00	CA	8.34	CBK-M2BMKIR	\$ 19.00	CA	8.36
CBK-KPPIT5*	\$ 78.30	CA	8.27	CBK-LBD60G	\$ 21.00	CA	8.34	CBK-M2BMKIY	\$ 19.00	CA	8.36
CBK-KPPIT6*	\$ 78.30	CA	8.27	CBK-LBD60L	\$ 21.00	CA	8.34	CBK-M2BMKR	\$ 13.00	CA	8.21
CBK-KPPIT7*	\$ 78.30	CA	8.27	CBK-LBD60R	\$ 21.00	CA	8.34	CBK-M2BML	\$ 13.00	CA	8.21
CBK-KPPIT8*	\$ 78.30	CA	8.27	CBK-LBD60W	\$ 21.00	CA	8.34	CBK-M2BMLE	\$ 13.00	CA	8.21
CBK-KPPITL1*	\$ 86.80	CA	8.27	CBK-LBD60Y	\$ 21.00	CA	8.34	CBK-M2BMLIC	\$ 19.00	CA	8.36
CBK-KPPITL2*	\$ 86.80	CA	8.27	CBK-LBD8G	\$ 15.00	CA	8.34	CBK-M2BMLIG	\$ 19.00	CA	8.36
CBK-KPPITL3*	\$ 86.80	CA	8.27	CBK-LBD8L	\$ 18.00	CA	8.34	CBK-M2BMLIL	\$ 19.00	CA	8.36
CBK-KPPITL4*	\$ 86.80	CA	8.27	CBK-LBD8R	\$ 15.00	CA	8.34	CBK-M2BMLIR	\$ 19.00	CA	8.36
CBK-KPPL	\$ 19.30	CA	8.15	CBK-LBD8W	\$ 18.00	CA	8.34	CBK-M2BMLIY	\$ 19.00	CA	8.36
CBK-KPPR	\$ 19.30	CA	8.15	CBK-LBD8Y	\$ 15.00	CA	8.34	CBK-M2BMLR	\$ 13.00	CA	8.21
CBK-KPPW	\$ 19.30	CA	8.15	CBK-LBDGF	\$ 20.00	CA	8.34	CBK-M2BSK	\$ 16.00	CA	8.21
CBK-KPPY	\$ 19.30	CA	8.15	CBK-LBDRF	\$ 20.00	CA	8.34	CBK-M2BSKE	\$ 16.00	CA	8.21
CBK-KPR	\$ 8.10	CA	8.14	CBK-LBDYF	\$ 20.00	CA	8.34	CBK-M2BSKIC	\$ 28.00	CA	8.36
CBK-KPW	\$ 8.10	CA	8.14	CBK-LBN2	\$ 6.00	CA	8.34	CBK-M2BSKIG	\$ 28.00	CA	8.36
CBK-KPY	\$ 8.10	CA	8.14	CBK-LMF	\$ 17.50	CA	8.34	CBK-M2BSKIL	\$ 28.00	CA	8.36
CBK-KR	\$ 1.00	CA	8.49	CBK-LMFB	\$ 17.50	CA	8.42	CBK-M2BSKIR	\$ 28.00	CA	8.36
CBK-KRS	\$ 1.00	CA	8.49	CBK-LMLED	\$ 21.50	CA	8.34	CBK-M2BSKIY	\$ 28.00	CA	8.36
CBK-KSP10K	\$ 110.00	CA	8.23	CBK-LMR1	\$ 21.50	CA	8.34	CBK-M2BSKR	\$ 16.00	CA	8.21
CBK-KSP10K4X	\$ 80.00	CA	8.23	CBK-LMR2	\$ 21.50	CA	8.34	CBK-M2BSL	\$ 16.00	CA	8.21
CBK-KSP10K4XP	\$ 90.00	CA	8.23	CBK-LMR24	\$ 21.50	CA	8.34	CBK-M2BSLE	\$ 16.00	CA	8.21
CBK-KSP5K	\$ 110.00	CA	8.23	CBK-LMRB1	\$ 21.50	CA	8.42	CBK-M2BSLIC	\$ 28.00	CA	8.36
CBK-KSP5K4X	\$ 80.00	CA	8.23	CBK-LMRB2	\$ 21.50	CA	8.42	CBK-M2BSLIG	\$ 28.00	CA	8.36
CBK-KSP5K4XP	\$ 90.00	CA	8.23	CBK-LMT1	\$ 35.00	CA	8.42	CBK-M2BSLIL	\$ 28.00	CA	8.36
CBK-KXB	\$ 8.00	CA	8.50	CBK-LMT124	\$ 35.00	CA	8.42	CBK-M2BSLIR	\$ 28.00	CA	8.36
CBK-KXBE	\$ 8.00	CA	8.50	CBK-LMT2	\$ 35.00	CA	8.42	CBK-M2BSLIY	\$ 28.00	CA	8.36
CBK-KXC	\$ 15.00	CA	8.50	CBK-LMT224	\$ 35.00	CA	8.42	CBK-M2BSLIR	\$ 16.00	CA	8.21
CBK-KXG	\$ 4.00	CA	8.50	CBK-LMT3	\$ 35.00	CA	8.42	CBK-M3A	\$ 10.00	CA	8.49
CBK-KXMT	\$ 10.00	CA	8.50	CBK-LMT324	\$ 35.00	CA	8.42	CBK-M3MK	\$ 13.00	CA	8.22
CBK-LB1	\$ 6.00	CA	8.34	CBK-LMT4	\$ 35.00	CA	8.42	CBK-M3MKE	\$ 13.00	CA	8.22
CBK-LB12	\$ 6.00	CA	8.34	CBK-LMT424	\$ 35.00	CA	8.42	CBK-M3MKIC	\$ 19.00	CA	8.37
CBK-LB24	\$ 6.00	CA	8.34	CBK-LT1	\$ 35.00	CA	8.34	CBK-M3MKIG	\$ 19.00	CA	8.37
CBK-LB30	\$ 6.00	CA	8.34	CBK-LT124	\$ 35.00	CA	8.34	CBK-M3MKIL	\$ 19.00	CA	8.37
CBK-LB48	\$ 6.00	CA	8.34	CBK-LT2	\$ 35.00	CA	8.34	CBK-M3MKIR	\$ 19.00	CA	8.37
CBK-LB6	\$ 6.00	CA	8.34	CBK-LT224	\$ 35.00	CA	8.34	CBK-M3MKIY	\$ 19.00	CA	8.37
CBK-LB60	\$ 6.00	CA	8.34	CBK-LT3	\$ 35.00	CA	8.34	CBK-M3MKR	\$ 13.00	CA	8.22
CBK-LBD12G	\$ 27.00	CA	8.34	CBK-LT324	\$ 35.00	CA	8.34	CBK-M3ML	\$ 13.00	CA	8.22
CBK-LBD12L	\$ 32.00	CA	8.34	CBK-LT4	\$ 35.00	CA	8.34	CBK-M3MLE	\$ 13.00	CA	8.22
CBK-LBD12R	\$ 27.00	CA	8.34	CBK-LT424	\$ 35.00	CA	8.34	CBK-M3MLIC	\$ 19.00	CA	8.37
CBK-LBD12W	\$ 32.00	CA	8.34	CBK-M2AMK	\$ 13.00	CA	8.21	CBK-M3MLIG	\$ 19.00	CA	8.37
CBK-LBD12Y	\$ 27.00	CA	8.34	CBK-M2AMKE	\$ 13.00	CA	8.21	CBK-M3MLIL	\$ 19.00	CA	8.37
CBK-LBD13G	\$ 21.00	CA	8.34	CBK-M2AMKIC	\$ 19.00	CA	8.36	CBK-M3MLIR	\$ 19.00	CA	8.37
CBK-LBD13L	\$ 28.00	CA	8.34	CBK-M2AMKIG	\$ 19.00	CA	8.36	CBK-M3MLIY	\$ 19.00	CA	8.37
CBK-LBD13R	\$ 21.00	CA	8.34	CBK-M2AMKIL	\$ 19.00	CA	8.36	CBK-M3MLR	\$ 13.00	CA	8.22
CBK-LBD13W	\$ 28.00	CA	8.34	CBK-M2AMKIR	\$ 19.00	CA	8.36	CBK-M3SK	\$ 16.00	CA	8.22
CBK-LBD13Y	\$ 21.00	CA	8.34	CBK-M2AMKIY	\$ 19.00	CA	8.36	CBK-M3SKE	\$ 16.00	CA	8.22
CBK-LBD1G	\$ 15.00	CA	8.34	CBK-M2AMKR	\$ 13.00	CA	8.21	CBK-M3SKIC	\$ 28.00	CA	8.37
CBK-LBD1L	\$ 18.00	CA	8.34	CBK-M2AML	\$ 13.00	CA	8.21	CBK-M3SKIG	\$ 28.00	CA	8.37

CBK-M3SKIL – CBK-MPPIT7*

Alphanumeric

0

Catalog number	List price	Discount schedule	Page number	Catalog number	List price	Discount schedule	Page number	Catalog number	List price	Discount schedule	Page number
CBK-M3SKIL	\$ 28.00	CA	8.37	CBK-MLTPT4*	\$ 80.00	CA	8.35	CBK-MPM40IT6*	\$ 76.00	CA	8.29
CBK-M3SKIR	\$ 28.00	CA	8.37	CBK-MLTPT5*	\$ 80.00	CA	8.35	CBK-MPM40IT7*	\$ 76.00	CA	8.29
CBK-M3SKIY	\$ 28.00	CA	8.37	CBK-MLTPT6*	\$ 80.00	CA	8.35	CBK-MPM40IT8*	\$ 76.00	CA	8.29
CBK-M3SKR	\$ 16.00	CA	8.22	CBK-MLTPT7*	\$ 80.00	CA	8.35	CBK-MPM40ITL1*	\$ 85.00	CA	8.29
CBK-M3SL	\$ 16.00	CA	8.22	CBK-MLTPT8*	\$ 80.00	CA	8.35	CBK-MPM40ITL2*	\$ 85.00	CA	8.29
CBK-M3SLE	\$ 16.00	CA	8.22	CBK-MLTPTL1*	\$ 80.00	CA	8.35	CBK-MPM40ITL3*	\$ 85.00	CA	8.29
CBK-M3SLIC	\$ 28.00	CA	8.37	CBK-MLTPTL2*	\$ 80.00	CA	8.35	CBK-MPM40ITL4*	\$ 85.00	CA	8.29
CBK-M3SLIG	\$ 28.00	CA	8.37	CBK-MLTPTL3*	\$ 80.00	CA	8.35	CBK-MPM6I*	\$ 21.50	CA	8.30
CBK-M3SLIL	\$ 28.00	CA	8.37	CBK-MLTPTL4*	\$ 80.00	CA	8.35	CBK-MPM6IF1*	\$ 45.00	CA	8.30
CBK-M3SLIR	\$ 28.00	CA	8.37	CBK-MPB	\$ 8.10	CA	8.14	CBK-MPM6IF6*	\$ 45.00	CA	8.30
CBK-M3SLIY	\$ 28.00	CA	8.37	CBK-MPC	\$ 8.10	CA	8.14	CBK-MPM6IF7*	\$ 45.00	CA	8.30
CBK-M3SLK	\$ 16.00	CA	8.22	CBK-MPEB	\$ 8.10	CA	8.14	CBK-MPM6IF8*	\$ 45.00	CA	8.30
CBK-M3SLKE	\$ 16.00	CA	8.22	CBK-MPEC	\$ 8.10	CA	8.14	CBK-MPM6IF9*	\$ 45.00	CA	8.30
CBK-M3SLKIC	\$ 28.00	CA	8.37	CBK-MPEG	\$ 8.10	CA	8.14	CBK-MPM6IFL1*	\$ 54.00	CA	8.30
CBK-M3SLKIG	\$ 28.00	CA	8.37	CBK-MPEL	\$ 8.10	CA	8.14	CBK-MPM6IFL2*	\$ 60.00	CA	8.30
CBK-M3SLKIL	\$ 28.00	CA	8.37	CBK-MPER	\$ 8.10	CA	8.14	CBK-MPM6IFL8*	\$ 54.00	CA	8.30
CBK-M3SLKIR	\$ 28.00	CA	8.37	CBK-MPEW	\$ 8.10	CA	8.14	CBK-MPM6IR1*	\$ 49.00	CA	8.30
CBK-M3SLKIY	\$ 28.00	CA	8.37	CBK-MPEY	\$ 8.10	CA	8.14	CBK-MPM6IR2*	\$ 49.00	CA	8.30
CBK-M3SLKR	\$ 16.00	CA	8.22	CBK-MPG	\$ 8.10	CA	8.14	CBK-MPM6IT1*	\$ 80.00	CA	8.30
CBK-M3SLL	\$ 16.00	CA	8.22	CBK-MPI*	\$ 8.10	CA	8.25	CBK-MPM6IT2*	\$ 80.00	CA	8.30
CBK-M3SLE	\$ 16.00	CA	8.22	CBK-MPIF1*	\$ 31.60	CA	8.25	CBK-MPM6IT3*	\$ 80.00	CA	8.30
CBK-M3SLLIC	\$ 28.00	CA	8.37	CBK-MPIF6*	\$ 31.60	CA	8.25	CBK-MPM6IT4*	\$ 80.00	CA	8.30
CBK-M3SLLIG	\$ 28.00	CA	8.37	CBK-MPIF7*	\$ 31.60	CA	8.25	CBK-MPM6IT5*	\$ 80.00	CA	8.30
CBK-M3SLLIL	\$ 28.00	CA	8.37	CBK-MPIF8*	\$ 31.60	CA	8.25	CBK-MPM6IT6*	\$ 80.00	CA	8.30
CBK-M3SLLIR	\$ 28.00	CA	8.37	CBK-MPIF9*	\$ 31.60	CA	8.25	CBK-MPM6IT7*	\$ 80.00	CA	8.30
CBK-M3SLLIY	\$ 28.00	CA	8.37	CBK-MPIFL1*	\$ 40.60	CA	8.25	CBK-MPM6IT8*	\$ 80.00	CA	8.30
CBK-M3SLLR	\$ 16.00	CA	8.22	CBK-MPIFL2*	\$ 46.60	CA	8.25	CBK-MPM6ITL1*	\$ 89.00	CA	8.30
CBK-M3SLR	\$ 16.00	CA	8.22	CBK-MPIFN2*	\$ 31.60	CA	8.25	CBK-MPM6ITL2*	\$ 89.00	CA	8.30
CBK-M3SRILG	\$ 28.00	CA	8.37	CBK-MPILF8*	\$ 40.60	CA	8.25	CBK-MPM6ITL3*	\$ 89.00	CA	8.30
CBK-M3SRK	\$ 16.00	CA	8.22	CBK-MPIR1*	\$ 35.60	CA	8.25	CBK-MPM6ITL4*	\$ 89.00	CA	8.30
CBK-M3SRKE	\$ 16.00	CA	8.22	CBK-MPIR2*	\$ 35.60	CA	8.25	CBK-MPPB	\$ 19.30	CA	8.15
CBK-M3SRKIC	\$ 28.00	CA	8.37	CBK-MPIT1*	\$ 66.60	CA	8.25	CBK-MPPC	\$ 19.30	CA	8.15
CBK-M3SRKIG	\$ 28.00	CA	8.37	CBK-MPIT2*	\$ 66.60	CA	8.25	CBK-MPPEB	\$ 19.30	CA	8.15
CBK-M3SRKIL	\$ 28.00	CA	8.37	CBK-MPIT3*	\$ 66.60	CA	8.25	CBK-MPPEC	\$ 19.30	CA	8.15
CBK-M3SRKIR	\$ 28.00	CA	8.37	CBK-MPIT4*	\$ 66.60	CA	8.25	CBK-MPPEG	\$ 19.30	CA	8.15
CBK-M3SRKIY	\$ 28.00	CA	8.37	CBK-MPIT5*	\$ 66.60	CA	8.25	CBK-MPPEL	\$ 19.30	CA	8.15
CBK-M3SRKR	\$ 16.00	CA	8.22	CBK-MPIT6*	\$ 66.60	CA	8.25	CBK-MPPER	\$ 19.30	CA	8.15
CBK-M3SRL	\$ 16.00	CA	8.22	CBK-MPIT7*	\$ 66.60	CA	8.25	CBK-MPPEW	\$ 19.30	CA	8.15
CBK-M3SRLC	\$ 28.00	CA	8.37	CBK-MPIT8*	\$ 66.60	CA	8.25	CBK-MPPEY	\$ 19.30	CA	8.15
CBK-M3SRLIL	\$ 28.00	CA	8.37	CBK-MPITL1*	\$ 75.60	CA	8.25	CBK-MPPG	\$ 19.30	CA	8.15
CBK-M3SRLIR	\$ 28.00	CA	8.37	CBK-MPITL2*	\$ 75.60	CA	8.25	CBK-MPPI*	\$ 19.30	CA	8.27
CBK-M3SRLIY	\$ 28.00	CA	8.37	CBK-MPITL3*	\$ 75.60	CA	8.25	CBK-MPPIF1*	\$ 42.80	CA	8.27
CBK-M3SRLR	\$ 16.00	CA	8.22	CBK-MPITL4*	\$ 75.60	CA	8.25	CBK-MPPIF6*	\$ 42.80	CA	8.27
CBK-MKNOB	\$ 20.00	CA	8.23	CBK-MPL	\$ 8.10	CA	8.14	CBK-MPPIF7*	\$ 42.80	CA	8.27
CBK-MLFPT1*	\$ 46.00	CA	8.35	CBK-MPM401*	\$ 17.50	CA	8.29	CBK-MPPIF8*	\$ 42.80	CA	8.27
CBK-MLFPT6*	\$ 46.00	CA	8.35	CBK-MPM40IF1*	\$ 41.00	CA	8.29	CBK-MPPIF9*	\$ 42.80	CA	8.27
CBK-MLFPT7*	\$ 46.00	CA	8.35	CBK-MPM40IF1L*	\$ 50.00	CA	8.29	CBK-MPPIFL1*	\$ 51.80	CA	8.27
CBK-MLFPT8*	\$ 46.00	CA	8.35	CBK-MPM40IF6*	\$ 41.00	CA	8.29	CBK-MPPIFL2*	\$ 57.80	CA	8.27
CBK-MLFPT9*	\$ 46.00	CA	8.35	CBK-MPM40IF7*	\$ 41.00	CA	8.29	CBK-MPPIFL8*	\$ 51.80	CA	8.27
CBK-MLFPTL1*	\$ 55.00	CA	8.35	CBK-MPM40IF8*	\$ 41.00	CA	8.29	CBK-MPPIFN2*	\$ 42.80	CA	8.27
CBK-MLFPTL2*	\$ 61.00	CA	8.35	CBK-MPM40IF9*	\$ 41.00	CA	8.29	CBK-MPPIR1*	\$ 47.30	CA	8.27
CBK-MLFPTL8*	\$ 55.00	CA	8.35	CBK-MPM40IFL2*	\$ 56.00	CA	8.29	CBK-MPPIR2*	\$ 47.30	CA	8.27
CBK-MLPT*	\$ 22.50	CA	8.35	CBK-MPM40IFL8*	\$ 50.00	CA	8.29	CBK-MPPIT*	\$ 78.30	CA	8.27
CBK-MLRPT1*	\$ 54.00	CA	8.35	CBK-MPM40IR1*	\$ 45.00	CA	8.29	CBK-MPPIT1*	\$ 78.30	CA	8.27
CBK-MLRPT2*	\$ 54.00	CA	8.35	CBK-MPM40IR2*	\$ 45.00	CA	8.29	CBK-MPPIT2*	\$ 78.30	CA	8.27
CBK-MLTPN2*	\$ 46.00	CA	8.35	CBK-MPM40IT1*	\$ 76.00	CA	8.29	CBK-MPPIT3*	\$ 78.30	CA	8.27
CBK-MLTPT1*	\$ 80.00	CA	8.35	CBK-MPM40IT2*	\$ 76.00	CA	8.29	CBK-MPPIT4*	\$ 78.30	CA	8.27
CBK-MLTPT2*	\$ 80.00	CA	8.35	CBK-MPM40IT3*	\$ 76.00	CA	8.29	CBK-MPPIT5*	\$ 78.30	CA	8.27
CBK-MLTPT3*	\$ 80.00	CA	8.35	CBK-MPM40IT4*	\$ 76.00	CA	8.29	CBK-MPPIT6*	\$ 78.30	CA	8.27
				CBK-MPM40IT5*	\$ 76.00	CA	8.29	CBK-MPPIT7*	\$ 78.30	CA	8.27

CBK-MPPITL1* – CBK-PK3A

Catalog number	List price	Discount schedule	Page number	Catalog number	List price	Discount schedule	Page number	Catalog number	List price	Discount schedule	Page number
CBK-MPPITL1*	\$ 86.80	CA	8.27	CBK-NPE15	\$ 1.50	CA	8.45	CBK-NPE28W-02	\$ 6.50	CA	8.47
CBK-MPPITL2*	\$ 86.80	CA	8.27	CBK-NPE15BA	\$ 1.50	CA	8.45	CBK-NPE28W-03	\$ 6.50	CA	8.47
CBK-MPPITL3*	\$ 86.80	CA	8.27	CBK-NPE16	\$ 1.50	CA	8.45	CBK-NPE28W-04	\$ 6.50	CA	8.47
CBK-MPPITL4*	\$ 86.80	CA	8.27	CBK-NPE16BA	\$ 1.50	CA	8.45	CBK-NPE28W-05	\$ 6.50	CA	8.47
CBK-MPPL	\$ 19.30	CA	8.15	CBK-NPE17	\$ 1.50	CA	8.45	CBK-NPE28W-06	\$ 6.50	CA	8.47
CBK-MPPR	\$ 19.30	CA	8.15	CBK-NPE17BA	\$ 1.50	CA	8.45	CBK-NPE28W-07	\$ 6.50	CA	8.47
CBK-MPPW	\$ 19.30	CA	8.15	CBK-NPE18	\$ 1.50	CA	8.45	CBK-NPE29	\$ 1.50	CA	8.45
CBK-MPPY	\$ 19.30	CA	8.15	CBK-NPE18BA	\$ 1.50	CA	8.45	CBK-NPE29-01	\$ 6.50	CA	8.47
CBK-MPR	\$ 8.10	CA	8.14	CBK-NPE19	\$ 1.50	CA	8.45	CBK-NPE29-02	\$ 6.50	CA	8.47
CBK-MPW	\$ 8.10	CA	8.14	CBK-NPE19BA	\$ 1.50	CA	8.45	CBK-NPE29-03	\$ 6.50	CA	8.47
CBK-MPY	\$ 8.10	CA	8.14	CBK-NPE2	\$ 1.50	CA	8.45	CBK-NPE29-04	\$ 6.50	CA	8.47
CBK-MSP10K4X	\$ 85.00	CA	8.23	CBK-NPE20	\$ 1.50	CA	8.45	CBK-NPE29-05	\$ 6.50	CA	8.47
CBK-MSP10K4XP	\$ 95.00	CA	8.23	CBK-NPE20BA	\$ 1.50	CA	8.45	CBK-NPE29-06	\$ 6.50	CA	8.47
CBK-MSP5K4X	\$ 85.00	CA	8.23	CBK-NPE21	\$ 1.50	CA	8.45	CBK-NPE29-07	\$ 6.50	CA	8.47
CBK-MSP5K4XP	\$ 95.00	CA	8.23	CBK-NPE21BA	\$ 1.50	CA	8.45	CBK-NPE29B-01	\$ 6.50	CA	8.47
CBK-MTM	\$ 20.00	CA	8.20	CBK-NPE22	\$ 1.50	CA	8.45	CBK-NPE29B-02	\$ 6.50	CA	8.47
CBK-MTM3	\$ 20.00	CA	8.20	CBK-NPE22AC	\$ 1.50	CA	8.45	CBK-NPE29B-03	\$ 6.50	CA	8.47
CBK-MTS	\$ 20.00	CA	8.20	CBK-NPE22BA	\$ 1.50	CA	8.45	CBK-NPE29B-04	\$ 6.50	CA	8.47
CBK-NE1BA	\$ 1.50	CA	8.45	CBK-NPE22BAAC	\$ 1.50	CA	8.45	CBK-NPE29B-05	\$ 6.50	CA	8.47
CBK-NE2BA	\$ 1.50	CA	8.45	CBK-NPE23	\$ 1.50	CA	8.45	CBK-NPE29B-06	\$ 6.50	CA	8.47
CBK-NP1	\$ 0.70	CA	8.45	CBK-NPE23AC	\$ 1.50	CA	8.45	CBK-NPE29B-07	\$ 6.50	CA	8.47
CBK-NP10	\$ 0.70	CA	8.45	CBK-NPE23BA	\$ 1.50	CA	8.45	CBK-NPE29BA	\$ 1.50	CA	8.45
CBK-NP11	\$ 0.70	CA	8.45	CBK-NPE23BAAC	\$ 1.50	CA	8.45	CBK-NPE29BA-01	\$ 6.50	CA	8.47
CBK-NP12	\$ 0.70	CA	8.45	CBK-NPE24	\$ 1.50	CA	8.45	CBK-NPE29BA-02	\$ 6.50	CA	8.47
CBK-NP13	\$ 0.70	CA	8.45	CBK-NPE24AC	\$ 1.50	CA	8.45	CBK-NPE29BA-03	\$ 6.50	CA	8.47
CBK-NP13AC	\$ 0.70	CA	8.45	CBK-NPE24BA	\$ 1.50	CA	8.45	CBK-NPE29BA-04	\$ 6.50	CA	8.47
CBK-NP14	\$ 0.70	CA	8.45	CBK-NPE24BAAC	\$ 1.50	CA	8.45	CBK-NPE29BA-05	\$ 6.50	CA	8.47
CBK-NP14AC	\$ 0.70	CA	8.45	CBK-NPE25	\$ 1.50	CA	8.45	CBK-NPE29BA-06	\$ 6.50	CA	8.47
CBK-NP15	\$ 0.70	CA	8.45	CBK-NPE25AC	\$ 1.50	CA	8.45	CBK-NPE29BA-07	\$ 6.50	CA	8.47
CBK-NP15AC	\$ 0.70	CA	8.45	CBK-NPE25BA	\$ 1.50	CA	8.45	CBK-NPE29P	\$ 1.50	CA	8.45
CBK-NP16	\$ 0.70	CA	8.45	CBK-NPE25BAAC	\$ 1.50	CA	8.45	CBK-NPE29W-01	\$ 6.50	CA	8.47
CBK-NP16AC	\$ 0.70	CA	8.45	CBK-NPE26	\$ 1.50	CA	8.45	CBK-NPE29W-02	\$ 6.50	CA	8.47
CBK-NP17	\$ 0.70	CA	8.45	CBK-NPE26BA	\$ 1.50	CA	8.45	CBK-NPE29W-03	\$ 6.50	CA	8.47
CBK-NP18	\$ 0.70	CA	8.45	CBK-NPE27	\$ 1.50	CA	8.45	CBK-NPE29W-04	\$ 6.50	CA	8.47
CBK-NP19	\$ 0.70	CA	8.45	CBK-NPE27BA	\$ 1.50	CA	8.45	CBK-NPE29W-05	\$ 6.50	CA	8.47
CBK-NP19-01	\$ 5.90	CA	8.46	CBK-NPE28	\$ 1.50	CA	8.45	CBK-NPE29W-06	\$ 6.50	CA	8.47
CBK-NP19-02	\$ 5.90	CA	8.46	CBK-NPE28-01	\$ 6.50	CA	8.47	CBK-NPE3	\$ 1.50	CA	8.45
CBK-NP19-03	\$ 5.90	CA	8.46	CBK-NPE28-02	\$ 6.50	CA	8.47	CBK-NPE30	\$ 6.00	CA	8.45
CBK-NP19-04	\$ 5.90	CA	8.46	CBK-NPE28-03	\$ 6.50	CA	8.47	CBK-NPE30P	\$ 5.00	CA	8.45
CBK-NP19-05	\$ 5.90	CA	8.46	CBK-NPE28-04	\$ 6.50	CA	8.47	CBK-NPE31	\$ 1.50	CA	8.45
CBK-NP2	\$ 0.70	CA	8.45	CBK-NPE28-05	\$ 6.50	CA	8.47	CBK-NPE31BA	\$ 1.50	CA	8.45
CBK-NP3	\$ 0.70	CA	8.45	CBK-NPE28-06	\$ 6.50	CA	8.47	CBK-NPE32	\$ 1.50	CA	8.45
CBK-NP4	\$ 0.70	CA	8.45	CBK-NPE28-07	\$ 6.50	CA	8.47	CBK-NPE32AC	\$ 1.50	CA	8.45
CBK-NP5	\$ 0.70	CA	8.45	CBK-NPE28B-01	\$ 6.50	CA	8.47	CBK-NPE32BA	\$ 1.50	CA	8.45
CBK-NP6	\$ 0.70	CA	8.45	CBK-NPE28B-02	\$ 6.50	CA	8.47	CBK-NPE32BAAC	\$ 1.50	CA	8.45
CBK-NP7	\$ 0.70	CA	8.45	CBK-NPE28B-03	\$ 6.50	CA	8.47	CBK-NPE34	\$ 5.00	CA	8.45
CBK-NP8	\$ 0.70	CA	8.45	CBK-NPE28B-04	\$ 6.50	CA	8.47	CBK-NPE3BA	\$ 1.50	CA	8.45
CBK-NP9	\$ 0.70	CA	8.45	CBK-NPE28B-05	\$ 6.50	CA	8.47	CBK-NPE4	\$ 1.50	CA	8.45
CBK-NPE/SP	\$ 10.00	CA	8.23	CBK-NPE28B-06	\$ 6.50	CA	8.47	CBK-NPE4BA	\$ 1.50	CA	8.45
CBK-NPE1	\$ 1.50	CA	8.45	CBK-NPE28B-07	\$ 6.50	CA	8.47	CBK-NPE5	\$ 1.50	CA	8.45
CBK-NPE10	\$ 1.50	CA	8.45	CBK-NPE28BA	\$ 1.50	CA	8.45	CBK-NPE5BA	\$ 1.50	CA	8.45
CBK-NPE10BA	\$ 1.50	CA	8.45	CBK-NPE28BA-01	\$ 6.50	CA	8.47	CBK-NPE6	\$ 1.50	CA	8.45
CBK-NPE11	\$ 1.50	CA	8.45	CBK-NPE28BA-02	\$ 6.50	CA	8.47	CBK-NPE6BA	\$ 1.50	CA	8.45
CBK-NPE11BA	\$ 1.50	CA	8.45	CBK-NPE28BA-03	\$ 6.50	CA	8.47	CBK-NPE7	\$ 1.50	CA	8.45
CBK-NPE12	\$ 1.50	CA	8.45	CBK-NPE28BA-04	\$ 6.50	CA	8.47	CBK-NPE7BA	\$ 1.50	CA	8.45
CBK-NPE12BA	\$ 1.50	CA	8.45	CBK-NPE28BA-05	\$ 6.50	CA	8.47	CBK-NPE8	\$ 1.50	CA	8.45
CBK-NPE13	\$ 1.50	CA	8.45	CBK-NPE28BA-06	\$ 6.50	CA	8.47	CBK-NPE8BA	\$ 1.50	CA	8.45
CBK-NPE13BA	\$ 1.50	CA	8.45	CBK-NPE28BA-07	\$ 6.50	CA	8.47	CBK-NPE9	\$ 1.50	CA	8.45
CBK-NPE14	\$ 1.50	CA	8.45	CBK-NPE28P	\$ 1.50	CA	8.45	CBK-NPE9BA	\$ 1.50	CA	8.45
CBK-NPE14BA	\$ 1.50	CA	8.45	CBK-NPE28W-01	\$ 6.50	CA	8.47	CBK-PK3A	\$ 8.00	CA	8.49

CBK-PKM1 – E10/220

Alphanumeric

0

Catalog number	List price	Discount schedule	Page number	Catalog number	List price	Discount schedule	Page number	Catalog number	List price	Discount schedule	Page number
CBK-PKM1	\$ 43.00	CA	8.19	CBKNPE29W-07	\$ 6.50	CA	8.47	DA75M-21A-11-84	\$ 935.00	DA	1.108
CBK-PKM2	\$ 43.00	CA	8.19	CC5-01	\$ 15.00	ABA	1.16	DB16E	\$ 15.00	ABA	2.22
CBK-PKM3	\$ 43.00	CA	8.19	CC5-10	\$ 15.00	ABA	1.16	DB200	\$ 60.00	TCA	2.7
CBK-PKS11	\$ 43.00	CA	8.19	CCL18-01	\$ 45.00	ABA	1.26	DB25/25A	\$ 30.00	TAA	2.7
CBK-PKS12	\$ 43.00	CA	8.19	CE3W9V6	\$ 22.70	RA	10.134	DB25/332A	\$ 38.00	TAA	2.7
CBK-PKS13	\$ 43.00	CA	8.19	CE3WSV6	\$ 22.70	RA	10.133	DB30C3P-F	\$ 55.00	DP	1.98
CBK-PKS21	\$ 43.00	CA	8.19	CE5-01D0.1	\$ 38.00	ABA	1.16	DB30C4P-F	\$ 75.00	DP	1.98
CBK-PKS22	\$ 43.00	CA	8.19	CE5-01D2	\$ 38.00	ABA	1.16	DB80	\$ 45.00	TBA	2.7
CBK-PKS23	\$ 43.00	CA	8.19	CE5-01W0.1	\$ 42.00	ABA	1.16	DINRAIL	\$ 52.00	H6	17.13
CBK-PKS31	\$ 43.00	CA	8.19	CE5-01W2	\$ 42.00	ABA	1.16	DLA12-30-84	\$ 131.00	AA	5.13
CBK-PKS32	\$ 43.00	CA	8.19	CE5-10D2	\$ 38.00	ABA	1.16	DLA16-30-84	\$ 153.00	AA	5.13
CBK-PKS33	\$ 43.00	CA	8.19	CE5-10W0.1	\$ 42.00	ABA	1.16	DLA26-30-84	\$ 234.00	AA	5.13
CBK-PKS41	\$ 43.00	CA	8.19	CE5-10W2	\$ 42.00	ABA	1.16	DLA9-30-84	\$ 117.00	AA	5.13
CBK-PKS42	\$ 43.00	CA	8.19	CGB-MPKM3	\$ 55.00	CC	8.68	DNC11-FBP.999	\$ 1,517.12	I/O	6.33
CBK-PKS43	\$ 43.00	CA	8.19	CGB-MPKS11	\$ 55.00	CC	8.68	DNF11-FBP.0	\$ 108.56	I/O	6.33
CBK-PKS51	\$ 43.00	CA	8.19	CGB-MPKS12	\$ 55.00	CC	8.68	DNF11-FBP.050	\$ 48.21	I/O	6.33
CBK-PKS52	\$ 43.00	CA	8.19	CGB-MPKS13	\$ 55.00	CC	8.68	DNM11-FBP.0	\$ 108.56	I/O	6.33
CBK-PKS53	\$ 43.00	CA	8.19	CGB-MPKS21	\$ 55.00	CC	8.68	DNM11-FBP.050	\$ 49.96	I/O	6.33
CBK-PKS61	\$ 43.00	CA	8.19	CGB-MPKS22	\$ 55.00	CC	8.68	DNP21-FBP.025	\$ 286.47	I/O	6.33
CBK-PKS62	\$ 43.00	CA	8.19	CGB-MPKS23	\$ 55.00	CC	8.68	DNP21-FBP.050	\$ 286.47	I/O	6.33
CBK-PKS63	\$ 43.00	CA	8.19	CGB-MPKS31	\$ 55.00	CC	8.68	DNP21-FBP.100	\$ 286.47	I/O	6.33
CBK-PM3A	\$ 10.00	CA	8.49	CGB-MPKS32	\$ 55.00	CC	8.68	DNP21-FBP.500	\$ 304.83	I/O	6.33
CBK-PMK40B	\$ 55.00	CA	8.16	CGB-MPKS33	\$ 55.00	CC	8.68	DNR11-FBP.120	\$ 37.22	I/O	6.33
CBK-PMK40R	\$ 55.00	CA	8.16	CGB-MPKS41	\$ 55.00	CC	8.68	DNX11-FBP.100	\$ 70.93	I/O	6.33
CBK-PMP3B	\$ 32.00	CA	8.16	CGB-MPKS42	\$ 55.00	CC	8.68	DNX11-FBP.300	\$ 114.96	I/O	6.33
CBK-PMP3R	\$ 32.00	CA	8.16	CGB-MPKS43	\$ 55.00	CC	8.68	DNX11-FBP.500	\$ 148.74	I/O	6.33
CBK-PMP40B	\$ 36.00	CA	8.16	CGB-MPKS51	\$ 55.00	CC	8.68	DP30C1P-F	\$ 30.00	DP	1.98
CBK-PMP40R	\$ 36.00	CA	8.16	CGB-MPKS52	\$ 55.00	CC	8.68	DP30C2P-F	\$ 38.00	DP	1.98
CBK-PMT3B	\$ 32.00	CA	8.16	CGB-MPKS53	\$ 55.00	CC	8.68	DP40C2P-F	\$ 46.00	DP	1.98
CBK-PMT3R	\$ 32.00	CA	8.16	CGB-MPKS61	\$ 55.00	CC	8.68	DP40C3P-F	\$ 60.00	DP	1.98
CBK-PMT40B	\$ 36.00	CA	8.16	CGB-MPKS62	\$ 55.00	CC	8.68	DP40C4P-F	\$ 100.00	DP	1.98
CBK-PMT40R	\$ 36.00	CA	8.16	CGB-MPKS63	\$ 55.00	CC	8.68	DP60C3P-F	\$ 147.00	DP	1.98
CBK-S2KM1	\$ 43.00	CA	8.24	CGB-PKS11	\$ 55.00	CC	8.68	DR25-A-110	\$ 60.00	TAA	2.8
CBK-S2KM4	\$ 43.00	CA	8.24	CGB-PKS12	\$ 55.00	CC	8.68	DR25-A-220/380	\$ 60.00	TAA	2.8
CBK-S2SK1	\$ 43.00	CA	8.24	CGB-PKS13	\$ 55.00	CC	8.68	DR25-A-24	\$ 60.00	TAA	2.8
CBK-S3KM2	\$ 55.00	CA	8.24	CGB-PKS21	\$ 55.00	CC	8.68	DR25-A-48	\$ 60.00	TAA	2.8
CBK-S3KM4	\$ 55.00	CA	8.24	CGB-PKS22	\$ 55.00	CC	8.68	DR25-A-500	\$ 60.00	TAA	2.8
CBK-S3KSR1	\$ 55.00	CA	8.24	CGB-PKS23	\$ 55.00	CC	8.68	DS-SA1	\$ 10.00	H6	17.13
CBK-SLKS2	\$ 55.00	CA	8.24	CGB-PKS31	\$ 55.00	CC	8.68	DS-SA2	\$ 28.00	H6	17.13
CBK-TM	\$ 20.00	CA	8.20	CGB-PKS32	\$ 55.00	CC	8.68	DS-SA3	\$ 38.00	H6	17.13
CBK-TM3	\$ 20.00	CA	8.20	CGB-PKS33	\$ 55.00	CC	8.68	DS25-A-110	\$ 60.00	TAA	2.8
CBK-TS	\$ 20.00	CA	8.20	CGB-PKS41	\$ 55.00	CC	8.68	DS25-A-220/380	\$ 60.00	TAA	2.8
CBK-XB2	\$ 8.00	CA	8.34	CGB-PKS42	\$ 55.00	CC	8.68	DS25-A-24	\$ 60.00	TAA	2.8
CBK-XBB	\$ 2.00	CA	8.40	CGB-PKS43	\$ 55.00	CC	8.68	DS25-A-48	\$ 60.00	TAA	2.8
CBK-XDIN	\$ 8.20	CA	8.51	CGB-PKS51	\$ 55.00	CC	8.68	DS25-A-500	\$ 60.00	TAA	2.8
CBK-XFC	\$ 5.00	CA	8.51	CGB-PKS52	\$ 55.00	CC	8.68	DSFHN-HS12	\$ 156.00	H6	17.97
CBK-XFL	\$ 3.00	CA	8.48	CGB-PKS53	\$ 55.00	CC	8.68	DSFHN-HS4	\$ 240.00	H6	17.97
CBK-XGS	\$ 0.50	CA	8.51	CGB-PKS61	\$ 55.00	CC	8.68	DSFHS-12	\$ 28.00	H6	17.97
CBK-XK3433-E	\$ 10.00	CA	8.50	CGB-PKS62	\$ 55.00	CC	8.68	DSFHS-17	\$ 40.00	H6	17.97
CBK-XK421	\$ 10.00	CA	8.50	CGB-PKS63	\$ 55.00	CC	8.68	DSFHS-22	\$ 52.00	H6	17.97
CBK-XK455	\$ 10.00	CA	8.50	CXBY68005	\$ 12.00	H6	17.22	DT450/A185	\$ 225.00	TCA	2.7
CBK-XLTL	\$ 10.00	CA	8.50	CXBY68100	\$ 2.00	H6	17.22	DT450/A300	\$ 225.00	TCA	2.7
CBK-XMG	\$ 16.00	CA	8.50	CXBY68135	\$ 8.00	H6	17.11	DT500/AF460L	\$ 395.00	ABA	2.22
CBK-XP	\$ 2.00	CA	8.50	CXBY68140	\$ 11.00	H6	17.19	DT500/AF460S	\$ 395.00	ABA	2.22
CBK-XPA	\$ 20.00	CA	8.50	CXBY68306	\$ 12.00	H6	17.11	DT800/AF750L	\$ 415.00	ABA	2.22
CBK-XRG	\$ 1.00	CA	8.50	CXBY68419/1	\$ 14.00	H6	17.11	DT800/AF750S	\$ 415.00	ABA	2.22
CBK-XSA	\$ 0.20	CA	8.51	DA75-20-11-84	\$ 310.00	DA	1.106	DX25	\$ 15.00	TAA	2.7
CBK-XSWG	\$ 8.00	CA	8.50	DA75-21-21-84	\$ 385.00	DA	1.106	DX495	\$ 45.00	MA	5.18
CBK-XSWL	\$ 35.00	CA	8.50	DA75-21A-11-84	\$ 430.00	DA	1.106	E10/110	\$ 24.00	CB20	14.52
CBK-XW	\$ 1.00	CAE	8.52	DA75M-20-11-84	\$ 780.00	DA	1.108	E10/220	\$ 24.00	CB20	14.52

E10/24 – F26D200-3FI

Catalog number	List price	Discount schedule	Page number	Catalog number	List price	Discount schedule	Page number	Catalog number	List price	Discount schedule	Page number
E10/24	\$ 24.00	CB20	14.52	E271/80	\$ 72.00	CB20	14.51	EHDBAS960-2	\$ 383.00	D	1.109
E16DU0.32-10	\$ 96.00	TS	2.21	E272/100	\$ 204.00	CB20	14.51	EHDBCK130-2	\$ 233.00	D	1.110
E16DU0.32-20	\$ 96.00	TS	2.21	E272/63	\$ 126.00	CB20	14.51	EHDBCK130-NC	\$ 143.00	D	1.110
E16DU0.32-30	\$ 96.00	TS	2.21	E272/80	\$ 150.00	CB20	14.51	EHDBCK220-2	\$ 300.00	D	1.110
E16DU1.0-10	\$ 96.00	TS	2.21	E273/100	\$ 306.00	CB20	14.51	EHDBCK220-NC	\$ 165.00	D	1.110
E16DU1.0-20	\$ 96.00	TS	2.21	E273/63	\$ 192.00	CB20	14.51	EHDBCK280-2	\$ 360.00	D	1.110
E16DU1.0-30	\$ 96.00	TS	2.21	E273/80	\$ 228.00	CB20	14.51	EHDBCK280-NC	\$ 165.00	D	1.110
E16DU18.9-10	\$ 96.00	TS	2.21	E274/100	\$ 410.00	CB20	14.51	EHDBCK360-2	\$ 698.00	D	1.110
E16DU18.9-20	\$ 96.00	TS	2.21	E274/63	\$ 258.00	CB20	14.51	EHDBCK360-NC	\$ 315.00	D	1.110
E16DU18.9-30	\$ 96.00	TS	2.21	E274/80	\$ 306.00	CB20	14.51	EHDBCK520-2	\$ 1,026.00	D	1.110
E16DU2.7-10	\$ 96.00	TS	2.21	E320DU320	\$ 775.00	TS	2.21	EHDBCK520-NC	\$ 513.00	D	1.110
E16DU2.7-20	\$ 96.00	TS	2.21	E500DU500	\$ 865.00	TS	2.21	EHDBCK650-2	\$ 1,368.00	D	1.110
E16DU2.7-30	\$ 96.00	TS	2.21	E800DU800	\$ 950.00	TS	2.21	EHDBCK650-NC	\$ 513.00	D	1.110
E16DU6.3-10	\$ 96.00	TS	2.21	EHDB130C-1L	\$ 863.00	DE	1.107	EHDBCK800-2	\$ 1,688.00	D	1.110
E16DU6.3-20	\$ 96.00	TS	2.21	EHDB130C2P-1L	\$ 675.00	DE	1.107	EHDBCK800-NC	\$ 690.00	D	1.110
E16DU6.3-30	\$ 96.00	TS	2.21	EHDB130M-1L	\$ 1,947.00	DE	1.108	EHDBCK960-2	\$ 2,115.00	D	1.110
E200DU200	\$ 325.00	TS	2.21	EHDB130M2P-1L	\$ 1,572.00	DE	1.108	EHDBCK960-NC	\$ 690.00	D	1.110
E221-10	\$ 59.00	CB20	14.50	EHDB220C-1L	\$ 998.00	DE	1.107	EHDBRC130-*	\$ 120.00	D	1.109
E221-11	\$ 90.00	CB20	14.50	EHDB220C2P-1L	\$ 698.00	DE	1.107	EHDBRC280-*	\$ 150.00	D	1.109
E221-20	\$ 110.00	CB20	14.50	EHDB220M-1L	\$ 2,253.00	DE	1.108	EHDBRC360-*	\$ 180.00	D	1.109
E221-22	\$ 177.00	CB20	14.50	EHDB220M2P-1L	\$ 1,653.00	DE	1.108	EHDBRC650-*	\$ 360.00	D	1.109
E221-30	\$ 120.00	CB20	14.50	EHDB280C-1L	\$ 1,290.00	DE	1.107	EHDBRC960-*	\$ 435.00	D	1.109
E221-31	\$ 177.00	CB20	14.50	EHDB280C2P-1L	\$ 945.00	DE	1.107	EHDRC280-*	\$ 150.00	D	1.109
E221-4	\$ 99.00	CB20	14.50	EHDB280M-1L	\$ 2,838.00	DE	1.108	EHDRC360-*	\$ 180.00	D	1.109
E221-4/2	\$ 147.00	CB20	14.50	EHDB280M2P-1L	\$ 2,148.00	DE	1.108	EHTK110	\$ 20.00	D	1.110
E221-40	\$ 159.00	CB20	14.50	EHDB360C-1L	\$ 2,820.00	DE	1.107	EHTK210	\$ 45.00	ABA	2.7
E221-6	\$ 69.00	CB20	14.50	EHDB360C2P-1L	\$ 1,950.00	DE	1.107	EHTK550N	\$ 75.00	D	1.110
E221-6/2	\$ 125.00	CB20	14.50	EHDB360M-1L	\$ 6,036.00	DE	1.108	EHTK700	\$ 100.00	D	1.110
E222-10	\$ 107.00	CB20	14.50	EHDB360M2P-1L	\$ 4,296.00	DE	1.108	EHTK800	\$ 225.00	D	1.110
E222-11	\$ 140.00	CB20	14.50	EHDB520C-1L	\$ 3,375.00	DE	1.107	EK1000C4P-1L	\$ 9,000.00	AEA	1.13
E222-20	\$ 141.00	CB20	14.50	EHDB520C2P-1L	\$ 2,250.00	DE	1.107	EK1000C4P-PL	\$ 9,700.00	AEA	1.13
E222-30	\$ 159.00	CB20	14.50	EHDB520M-1L	\$ 7,236.00	DE	1.108	EK110C4P-1L	\$ 743.00	AEA	1.13
E222-4	\$ 150.00	CB20	14.50	EHDB520M2P-1L	\$ 4,986.00	DE	1.108	EK110C4P-PL	\$ 953.00	AEA	1.13
E222-40	\$ 239.00	CB20	14.50	EHDB650C-1L	\$ 4,650.00	DE	1.107	EK150C4P-1L	\$ 1,013.00	AEA	1.13
E222-6	\$ 128.00	CB20	14.50	EHDB650C2P-1L	\$ 3,953.00	DE	1.107	EK150C4P-PL	\$ 1,238.00	AEA	1.13
E225-11B	\$ 75.00	CB20	14.52	EHDB650M-1L	\$ 9,786.00	DE	1.108	EK175C4P-1L	\$ 1,763.00	AEA	1.13
E225-11C	\$ 75.00	CB20	14.52	EHDB650M2P-1L	\$ 8,391.00	DE	1.108	EK175C4P-PL	\$ 1,988.00	AEA	1.13
E225-11D	\$ 75.00	CB20	14.52	EHDB800C-1L	\$ 5,700.00	DE	1.107	EK210C4P-1L	\$ 2,025.00	AEA	1.13
E225-11E	\$ 75.00	CB20	14.52	EHDB800C2P-1L	\$ 4,845.00	DE	1.107	EK210C4P-PL	\$ 2,280.00	AEA	1.13
E225-11F	\$ 75.00	CB20	14.52	EHDB800M-1L	\$ 11,976.00	DE	1.108	EK370C4P-1L	\$ 4,650.00	AEA	1.13
E225-11G	\$ 75.00	CB20	14.52	EHDB800M2P-1L	\$ 10,266.00	DE	1.108	EK370C4P-PL	\$ 5,010.00	AEA	1.13
E227-10B/110	\$ 100.00	CB20	14.52	EHDB960C-1L	\$ 7,200.00	DE	1.107	EK550C4P-1L	\$ 6,510.00	AEA	1.13
E227-10C/110	\$ 100.00	CB20	14.52	EHDB960C2P-1L	\$ 6,120.00	DE	1.107	EK550C4P-PL	\$ 7,005.00	AEA	1.13
E227-10D/110	\$ 100.00	CB20	14.52	EHDB960M-1L	\$ 14,976.00	DE	1.108	F26D100	\$ 1,922.00	F2	19.21
E227-10E/110	\$ 100.00	CB20	14.52	EHDB960M2P-1L	\$ 12,816.00	DE	1.108	F26D100-3FI	\$ 2,457.00	F2	19.23
E227-10G/110	\$ 100.00	CB20	14.52	EHDBAS130	\$ 173.00	D	1.109	F26D110	\$ 2,136.00	F2	19.21
E229-B/110	\$ 93.00	CB20	14.52	EHDBAS130-2	\$ 165.00	D	1.109	F26D110-3FI	\$ 2,617.00	F2	19.23
E229-C/110	\$ 93.00	CB20	14.52	EHDBAS220	\$ 200.00	D	1.109	F26D120	\$ 2,296.00	F2	19.21
E229-D/110	\$ 93.00	CB20	14.52	EHDBAS220-2	\$ 192.00	D	1.109	F26D120-3FI	\$ 2,778.00	F2	19.23
E229-E/110	\$ 93.00	CB20	14.52	EHDBAS280	\$ 233.00	D	1.109	F26D130	\$ 2,510.00	F2	19.21
E229-G/110	\$ 93.00	CB20	14.52	EHDBAS280-2	\$ 221.00	D	1.109	F26D130-3FI	\$ 2,992.00	F2	19.23
E233-120/60	\$ 130.00	CB20	14.52	EHDBAS360	\$ 254.00	D	1.109	F26D140-3FI	\$ 1,654.00	F2	19.23
E233-24/60	\$ 130.00	CB20	14.52	EHDBAS360-2	\$ 242.00	D	1.109	F26D150	\$ 2,671.00	F2	19.21
E233-240/60	\$ 130.00	CB20	14.52	EHDBAS520	\$ 305.00	D	1.109	F26D150-3FI	\$ 3,259.00	F2	19.23
E241/45	\$ 54.00	CB20	14.51	EHDBAS520-2	\$ 293.00	D	1.109	F26D160	\$ 3,045.00	F2	19.21
E242/45	\$ 114.00	CB20	14.51	EHDBAS650	\$ 350.00	D	1.109	F26D160-3FI	\$ 3,473.00	F2	19.23
E243/45	\$ 174.00	CB20	14.51	EHDBAS650-2	\$ 338.00	D	1.109	F26D180	\$ 3,259.00	F2	19.21
E244/45	\$ 234.00	CB20	14.51	EHDBAS800	\$ 371.00	D	1.109	F26D180-3FI	\$ 3,794.00	F2	19.23
E271/100	\$ 96.00	CB20	14.51	EHDBAS800-2	\$ 357.00	D	1.109	F26D200	\$ 3,794.00	F2	19.21
E271/63	\$ 60.00	CB20	14.51	EHDBAS960	\$ 396.00	D	1.109	F26D200-3FI	\$ 4,222.00	F2	19.23

F26D250 – F48G500

Alphanumeric

0

Catalog number	List price	Discount schedule	Page number	Catalog number	List price	Discount schedule	Page number	Catalog number	List price	Discount schedule	Page number
F26D250	\$ 4,864.00	F2	19.21	F26R90	\$ 1,815.00	F2	19.21	F48D160-3FI	\$ 1,815.00	F2	19.23
F26D250-3FI	\$ 5,292.00	F2	19.23	F26R90-3FI	\$ 2,136.00	F2	19.23	F48D175	\$ 1,671.00	F2	19.21
F26D300	\$ 5,506.00	F2	19.21	F372-16/0.01	\$ 590.00	CB14	14.46	F48D175-3FI	\$ 1,922.00	F2	19.23
F26D300-3FI	\$ 5,827.00	F2	19.23	F372-25/0.03	\$ 408.00	CB14	14.46	F48D180	\$ 1,783.00	F2	19.21
F26D70	\$ 1,424.00	F2	19.21	F372-25/0.1	\$ 408.00	CB14	14.46	F48D180-3FI	\$ 1,975.00	F2	19.23
F26D70-3FI	\$ 1,674.00	F2	19.23	F372-25/0.3	\$ 288.00	CB14	14.46	F48D200	\$ 1,890.00	F2	19.21
F26D80	\$ 1,612.00	F2	19.21	F372-40/0.03	\$ 464.00	CB14	14.46	F48D200-3FI	\$ 2,082.00	F2	19.23
F26D80-3FI	\$ 1,895.00	F2	19.23	F372-40/0.1	\$ 464.00	CB14	14.46	F48D240	\$ 2,211.00	F2	19.21
F26D90	\$ 1,815.00	F2	19.21	F372-40/0.3	\$ 320.00	CB14	14.46	F48D240-3FI	\$ 2,564.00	F2	19.23
F26D90-3FI	\$ 2,136.00	F2	19.23	F372-63/0.03	\$ 660.00	CB14	14.46	F48D250	\$ 2,377.00	F2	19.21
F26F160	\$ 2,996.00	F2	19.21	F372-63/0.1	\$ 660.00	CB14	14.46	F48D250-3FI	\$ 2,724.00	F2	19.23
F26G100	\$ 1,873.00	F2	19.21	F372-63/0.3	\$ 474.00	CB14	14.46	F48D260	\$ 2,510.00	F2	19.21
F26G100-3FI	\$ 2,408.00	F2	19.23	F374-25/0.03	\$ 426.00	CB14	14.46	F48D260-3FI	\$ 2,831.00	F2	19.23
F26G110	\$ 2,087.00	F2	19.21	F374-25/0.1	\$ 426.00	CB14	14.46	F48D280	\$ 2,617.00	F2	19.21
F26G110-3FI	\$ 2,568.00	F2	19.23	F374-25/0.3	\$ 302.00	CB14	14.46	F48D280-3FI	\$ 2,938.00	F2	19.23
F26G120	\$ 2,247.00	F2	19.21	F374-25/0.5	\$ 302.00	CB14	14.46	F48D300	\$ 2,724.00	F2	19.21
F26G120-3FI	\$ 2,729.00	F2	19.23	F374-40/0.03	\$ 486.00	CB14	14.46	F48D300-3FI	\$ 3,045.00	F2	19.23
F26G130	\$ 2,461.00	F2	19.21	F374-40/0.1	\$ 486.00	CB14	14.46	F48D350	\$ 3,045.00	F2	19.21
F26G130-3FI	\$ 2,943.00	F2	19.23	F374-40/0.3	\$ 342.00	CB14	14.46	F48D350-3FI	\$ 3,580.00	F2	19.23
F26G150	\$ 2,622.00	F2	19.21	F374-40/0.5	\$ 342.00	CB14	14.46	F48D360	\$ 3,259.00	F2	19.21
F26G150-3FI	\$ 3,210.00	F2	19.23	F374-63/0.03	\$ 726.00	CB14	14.46	F48D360-3FI	\$ 3,741.00	F2	19.23
F26G160-3FI	\$ 3,424.00	F2	19.23	F374-63/0.1	\$ 726.00	CB14	14.46	F48D400	\$ 3,687.00	F2	19.21
F26G180	\$ 3,210.00	F2	19.21	F374-63/0.3	\$ 494.00	CB14	14.46	F48D400-3FI	\$ 4,222.00	F2	19.23
F26G180-3FI	\$ 3,745.00	F2	19.23	F374-63/0.5	\$ 494.00	CB14	14.46	F48D450	\$ 4,383.00	F2	19.21
F26G200	\$ 3,745.00	F2	19.21	F46D125	\$ 1,350.00	F2	19.21	F48D450-3FI	\$ 4,918.00	F2	19.23
F26G200-3FI	\$ 4,173.00	F2	19.23	F46D125-3FI	\$ 1,574.00	F2	19.23	F48D475	\$ 4,650.00	F2	19.21
F26G250	\$ 4,815.00	F2	19.21	F46D130	\$ 1,424.00	F2	19.21	F48D475-3FI	\$ 5,292.00	F2	19.23
F26G250-3FI	\$ 5,243.00	F2	19.23	F46D130-3FI	\$ 1,628.00	F2	19.23	F48D500	\$ 4,864.00	F2	19.21
F26G300	\$ 5,457.00	F2	19.21	F46D140	\$ 1,478.00	F2	19.21	F48D500-3FI	\$ 5,613.00	F2	19.23
F26G300-3FI	\$ 5,778.00	F2	19.23	F46D150	\$ 1,499.00	F2	19.21	F48D600	\$ 5,506.00	F2	19.21
F26G70	\$ 1,375.00	F2	19.21	F46D150-3FI	\$ 1,735.00	F2	19.23	F48D600-3FI	\$ 6,148.00	F2	19.23
F26G70-3FI	\$ 1,625.00	F2	19.23	F46D220	\$ 2,029.00	F2	19.21	F48G160	\$ 1,520.00	F2	19.21
F26G80	\$ 1,563.00	F2	19.21	F46D220-3FI	\$ 2,323.00	F2	19.23	F48G160-3FI	\$ 1,766.00	F2	19.23
F26G80-3FI	\$ 1,846.00	F2	19.23	F46D225	\$ 2,131.00	F2	19.21	F48G175	\$ 1,622.00	F2	19.21
F26G90	\$ 1,766.00	F2	19.21	F46G125	\$ 1,301.00	F2	19.21	F48G175-3FI	\$ 1,873.00	F2	19.23
F26G90-3FI	\$ 2,087.00	F2	19.23	F46G125-3FI	\$ 1,525.00	F2	19.23	F48G180	\$ 1,734.00	F2	19.21
F26R100	\$ 1,922.00	F2	19.21	F46G130	\$ 1,375.00	F2	19.21	F48G180-3FI	\$ 1,926.00	F2	19.23
F26R100-3FI	\$ 2,457.00	F2	19.23	F46G130-3FI	\$ 1,579.00	F2	19.23	F48G200	\$ 1,841.00	F2	19.21
F26R110	\$ 2,136.00	F2	19.21	F46G140	\$ 1,429.00	F2	19.21	F48G200-3FI	\$ 2,033.00	F2	19.23
F26R110-3FI	\$ 2,617.00	F2	19.23	F46G140-3FI	\$ 1,605.00	F2	19.23	F48G240	\$ 2,162.00	F2	19.21
F26R120	\$ 2,296.00	F2	19.21	F46G150	\$ 1,450.00	F2	19.21	F48G240-3FI	\$ 2,515.00	F2	19.23
F26R120-3FI	\$ 2,778.00	F2	19.23	F46G150-3FI	\$ 1,686.00	F2	19.23	F48G250	\$ 2,328.00	F2	19.21
F26R130	\$ 2,510.00	F2	19.21	F46G220	\$ 1,980.00	F2	19.21	F48G250-3FI	\$ 2,675.00	F2	19.23
F26R130-3FI	\$ 2,992.00	F2	19.23	F46G220-3FI	\$ 2,274.00	F2	19.23	F48G260	\$ 2,461.00	F2	19.21
F26R150	\$ 2,671.00	F2	19.21	F46G225	\$ 2,082.00	F2	19.21	F48G260-3FI	\$ 2,782.00	F2	19.23
F26R150-3FI	\$ 3,259.00	F2	19.23	F46G225-3FI	\$ 2,435.00	F2	19.23	F48G280	\$ 2,568.00	F2	19.21
F26R160	\$ 3,045.00	F2	19.21	F46R125	\$ 1,350.00	F2	19.21	F48G280-3FI	\$ 2,889.00	F2	19.23
F26R160-3FI	\$ 3,473.00	F2	19.23	F46R125-3FI	\$ 1,574.00	F2	19.23	F48G300	\$ 2,675.00	F2	19.21
F26R180	\$ 3,259.00	F2	19.21	F46R130	\$ 1,424.00	F2	19.21	F48G300-3FI	\$ 2,996.00	F2	19.23
F26R180-3FI	\$ 3,794.00	F2	19.23	F46R130-3FI	\$ 1,628.00	F2	19.23	F48G350	\$ 2,996.00	F2	19.21
F26R200	\$ 3,794.00	F2	19.21	F46R140	\$ 1,478.00	F2	19.21	F48G350-3FI	\$ 3,531.00	F2	19.23
F26R200-3FI	\$ 4,222.00	F2	19.23	F46R140-3FI	\$ 1,654.00	F2	19.23	F48G360	\$ 3,210.00	F2	19.21
F26R250	\$ 4,864.00	F2	19.21	F46R150	\$ 1,499.00	F2	19.21	F48G360-3FI	\$ 3,692.00	F2	19.23
F26R250-3FI	\$ 5,292.00	F2	19.23	F46R150-3FI	\$ 1,735.00	F2	19.23	F48G400	\$ 3,638.00	F2	19.21
F26R300	\$ 5,506.00	F2	19.21	F46R220	\$ 2,029.00	F2	19.21	F48G400-3FI	\$ 4,173.00	F2	19.23
F26R300-3FI	\$ 5,827.00	F2	19.23	F46R220-3FI	\$ 2,323.00	F2	19.23	F48G450	\$ 4,334.00	F2	19.21
F26R70	\$ 1,815.00	F2	19.21	F46R225	\$ 2,131.00	F2	19.21	F48G450-3FI	\$ 4,869.00	F2	19.23
F26R70-3FI	\$ 1,674.00	F2	19.23	F46R225-3FI	\$ 2,484.00	F2	19.23	F48G475	\$ 4,601.00	F2	19.21
F26R80	\$ 1,612.00	F2	19.21	F486D225-3FI	\$ 2,484.00	F2	19.23	F48G475-3FI	\$ 5,243.00	F2	19.23
F26R80-3FI	\$ 1,895.00	F2	19.23	F48D160	\$ 1,569.00	F2	19.21	F48G500	\$ 4,815.00	F2	19.21

F48G500-3FI – FJ1004-4PB8B

Catalog number	List price	Discount schedule	Page number	Catalog number	List price	Discount schedule	Page number	Catalog number	List price	Discount schedule	Page number
F48G500-3FI	\$ 5,564.00	F2	19.23	F674-125/0.03	\$ 1,800.00	CB14	14.46	FC301-4PB6B	\$ 700.00	H4E	17.142
F48G600	\$ 5,457.00	F2	19.21	F674-125/0.1	\$ 1,800.00	CB14	14.46	FC301-6PB6B	\$ 1,300.00	H4E	17.143
F48G600-3FI	\$ 6,099.00	F2	19.23	F674-125/0.3	\$ 1,600.00	CB14	14.46	FC302-3BB6B	\$ 2,150.00	H4E	17.144
F48R160	\$ 1,569.00	F2	19.21	F674-80/0.03	\$ 1,300.00	CB14	14.46	FC302-3MB6B	\$ 1,650.00	H4E	17.143
F48R160-3FI	\$ 1,815.00	F2	19.23	F674-80/0.1	\$ 1,300.00	CB14	14.46	FC302-3PB6B	\$ 600.00	H4E	17.143
F48R175	\$ 1,671.00	F2	19.21	F674-80/0.3	\$ 1,200.00	CB14	14.46	FC302-3TB6B	\$ 1,650.00	H4E	17.144
F48R175-3FI	\$ 1,922.00	F2	19.23	F68D200	\$ 1,975.00	F2	19.22	FC302-4PB6B	\$ 750.00	H4E	17.142
F48R180	\$ 1,783.00	F2	19.21	F68D200-3FI	\$ 2,189.00	F2	19.24	FC302-6PB6B	\$ 1,480.00	H4E	17.143
F48R180-3FI	\$ 1,975.00	F2	19.23	F68D270	\$ 2,724.00	F2	19.22	FC303-3BB8B	\$ 2,050.00	H4E	17.144
F48R200	\$ 1,890.00	F2	19.21	F68D270-3FI	\$ 2,992.00	F2	19.24	FC303-3MB6B	\$ 1,560.00	H4E	17.143
F48R200-3FI	\$ 2,082.00	F2	19.23	F68D300	\$ 2,938.00	F2	19.22	FC303-3PB6B	\$ 600.00	H4E	17.143
F48R240	\$ 2,211.00	F2	19.21	F68D300-3FI	\$ 3,259.00	F2	19.24	FC303-3TB6B	\$ 1,560.00	H4E	17.144
F48R240-3FI	\$ 2,564.00	F2	19.23	F68D350	\$ 3,259.00	F2	19.22	FC303-4PB6B	\$ 750.00	H4E	17.142
F48R250	\$ 2,377.00	F2	19.21	F68D350-3FI	\$ 3,794.00	F2	19.24	FC303-6PB6B	\$ 1,400.00	H4E	17.143
F48R250-3FI	\$ 2,724.00	F2	19.23	F68D360	\$ 3,420.00	F2	19.22	FC304-3BB8B	\$ 3,150.00	H4E	17.144
F48R260	\$ 2,510.00	F2	19.21	F68D360-3FI	\$ 4,062.00	F2	19.24	FC304-3MB6B	\$ 2,400.00	H4E	17.143
F48R260-3FI	\$ 2,831.00	F2	19.23	F68D400	\$ 4,008.00	F2	19.22	FC304-3PB6B	\$ 1,100.00	H4E	17.143
F48R280	\$ 2,617.00	F2	19.21	F68D400-3FI	\$ 4,329.00	F2	19.24	FC304-3TB6B	\$ 2,400.00	H4E	17.144
F48R280-3FI	\$ 2,938.00	F2	19.23	F68D500	\$ 5,613.00	F2	19.22	FC304-4PB6B	\$ 1,375.00	H4E	17.142
F48R300	\$ 2,724.00	F2	19.21	F68D500-3FI	\$ 6,469.00	F2	19.24	FC304-6PB6B	\$ 2,150.00	H4E	17.143
F48R300-3FI	\$ 3,045.00	F2	19.23	F68D600	\$ 6,469.00	F2	19.22	FC30P-3BB6B	\$ 2,250.00	H4E	17.144
F48R350	\$ 3,045.00	F2	19.21	F68D600-3FI	\$ 7,539.00	F2	19.24	FC30P-3MB6B	\$ 1,750.00	H4E	17.143
F48R350-3FI	\$ 3,580.00	F2	19.23	F68G200	\$ 1,926.00	F2	19.22	FC30P-3PB6B	\$ 1,040.00	H4E	17.143
F48R360	\$ 3,259.00	F2	19.21	F68G200-3FI	\$ 2,140.00	F2	19.24	FC30P-3TB6B	\$ 1,750.00	H4E	17.144
F48R360-3FI	\$ 3,741.00	F2	19.23	F68G270	\$ 2,675.00	F2	19.22	FC30P-4PB6B	\$ 1,300.00	H4E	17.142
F48R400	\$ 3,687.00	F2	19.21	F68G270-3FI	\$ 2,943.00	F2	19.24	FC30P-6PB6B	\$ 1,575.00	H4E	17.143
F48R400-3FI	\$ 4,222.00	F2	19.23	F68G300	\$ 2,889.00	F2	19.22	FC30X-3BB8B	\$ 4,550.00	H4E	17.144
F48R450	\$ 4,383.00	F2	19.21	F68G300-3FI	\$ 3,210.00	F2	19.24	FC30X-3MB6B	\$ 3,500.00	H4E	17.143
F48R450-3FI	\$ 4,918.00	F2	19.23	F68G320	\$ 3,050.00	F2	19.22	FC30X-3PB6B	\$ 1,400.00	H4E	17.143
F48R475	\$ 4,650.00	F2	19.21	F68G350	\$ 3,210.00	F2	19.22	FC30X-3TB6B	\$ 3,500.00	H4E	17.144
F48R475-3FI	\$ 5,292.00	F2	19.23	F68G350-3FI	\$ 3,745.00	F2	19.24	FC30X-4PB6B	\$ 1,750.00	H4E	17.142
F48R500	\$ 4,864.00	F2	19.21	F68G360	\$ 3,371.00	F2	19.22	FC30X-6PB6B	\$ 3,020.00	H4E	17.143
F48R500-3FI	\$ 5,613.00	F2	19.23	F68G360-3FI	\$ 4,013.00	F2	19.24	FDP21-FBP.050	\$ 390.39	I/O	6.34
F48R600	\$ 5,506.00	F2	19.21	F68G400	\$ 3,959.00	F2	19.22	FDP21-FBP.100	\$ 390.39	I/O	6.34
F48R600-3FI	\$ 6,148.00	F2	19.23	F68G400-3FI	\$ 4,280.00	F2	19.24	FDP21-FBP.500	\$ 409.43	I/O	6.34
F66D160	\$ 1,654.00	F2	19.22	F68G500	\$ 5,564.00	F2	19.22	FH-3RL	\$ 30.00	SH	15.60
F66D160-3FI	\$ 1,868.00	F2	19.24	F68G500-3FI	\$ 6,420.00	F2	19.24	FH-DHK	\$ 150.00	SH	15.60
F66D240	\$ 2,403.00	F2	19.22	F68G600	\$ 6,420.00	F2	19.22	FJ1001-2PB8B	\$ 864.00	H4E	17.142
F66D240-3FI	\$ 2,724.00	F2	19.24	F68G600-3FI	\$ 7,490.00	F2	19.24	FJ1001-3MB8B	\$ 2,220.00	H4E	17.143
F66D320	\$ 3,099.00	F2	19.22	F68R200	\$ 1,975.00	F2	19.22	FJ1001-3PB8B	\$ 960.00	H4E	17.143
F66D320-3FI	\$ 3,473.00	F2	19.24	F68R200-3FI	\$ 2,189.00	F2	19.24	FJ1001-3TB8B	\$ 2,220.00	H4E	17.144
F66G160	\$ 1,605.00	F2	19.22	F68R270	\$ 2,724.00	F2	19.22	FJ1001-4PB8B	\$ 1,200.00	H4E	17.142
F66G160-3FI	\$ 1,819.00	F2	19.24	F68R270-3FI	\$ 2,992.00	F2	19.24	FJ1001-6PB4B	\$ 2,000.00	H4E	17.143
F66G240	\$ 2,354.00	F2	19.22	F68R300	\$ 2,938.00	F2	19.22	FJ1002-2PB8B	\$ 1,026.00	H4E	17.142
F66G240-3FI	\$ 2,675.00	F2	19.24	F68R300-3FI	\$ 3,259.00	F2	19.24	FJ1002-3MB8B	\$ 2,580.00	H4E	17.143
F66G320-3FI	\$ 3,424.00	F2	19.24	F68R350	\$ 3,259.00	F2	19.22	FJ1002-3PB8B	\$ 1,140.00	H4E	17.143
F66R160	\$ 1,654.00	F2	19.22	F68R350-3FI	\$ 3,794.00	F2	19.24	FJ1002-3TB8B	\$ 2,580.00	H4E	17.144
F66R160-3FI	\$ 1,868.00	F2	19.24	F68R360	\$ 3,420.00	F2	19.22	FJ1002-4PB8B	\$ 1,425.00	H4E	17.142
F66R240	\$ 2,403.00	F2	19.22	F68R360-3FI	\$ 4,062.00	F2	19.24	FJ1002-6PB4B	\$ 2,350.00	H4E	17.143
F66R240-3FI	\$ 2,724.00	F2	19.24	F68R400	\$ 4,008.00	F2	19.22	FJ1003-2PB8B	\$ 1,026.00	H4E	17.142
F66R320	\$ 3,099.00	F2	19.22	F68R400-3FI	\$ 4,329.00	F2	19.24	FJ1003-3MB8B	\$ 2,440.00	H4E	17.143
F66R320-3FI	\$ 3,473.00	F2	19.24	F68R500	\$ 5,613.00	F2	19.22	FJ1003-3PB8B	\$ 1,140.00	H4E	17.143
F672-100/0.03	\$ 2,200.00	CB14	14.46	F68R500-3FI	\$ 6,469.00	F2	19.24	FJ1003-3TB8B	\$ 2,240.00	H4E	17.144
F672-100/0.1	\$ 2,200.00	CB14	14.46	F68R600	\$ 4,469.00	F2	19.22	FJ1003-4PB8B	\$ 1,425.00	H4E	17.142
F672-100/0.3	\$ 1,800.00	CB14	14.46	F68R600-3FI	\$ 7,539.00	F2	19.24	FJ1003-6PB4B	\$ 2,200.00	H4E	17.143
F672-80/0.03	\$ 1,600.00	CB14	14.46	FBWM	\$ 500.00	F2	19.22	FJ1004-2PB8B	\$ 2,735.00	H4E	17.142
F672-80/0.1	\$ 1,600.00	CB14	14.46	FC301-3BB8B	\$ 1,850.00	H4E	17.144	FJ1004-3MB8B	\$ 3,750.00	H4E	17.143
F672-80/0.3	\$ 1,300.00	CB14	14.46	FC301-3MB6B	\$ 1,420.00	H4E	17.143	FJ1004-3PB8B	\$ 2,800.00	H4E	17.143
F674-100/0.03	\$ 1,800.00	CB14	14.46	FC301-3PB6B	\$ 560.00	H4E	17.143	FJ1004-3TB8B	\$ 3,750.00	H4E	17.144
F674-100/0.3	\$ 1,600.00	CB14	14.46	FC301-3TB6B	\$ 1,420.00	H4E	17.144	FJ1004-4PB8B	\$ 3,800.00	H4E	17.142

FJ1004-6PB4B – FJ601-6PB4B

Alphanumeric

0

Catalog number	List price	Discount schedule	Page number	Catalog number	List price	Discount schedule	Page number	Catalog number	List price	Discount schedule	Page number
FJ1004-6PB4B	\$ 3,375.00	H4E	17.143	FJ301-6PB6B	\$ 1,300.00	H4E	17.143	FJ400P-3B6B	\$ 33,100.00	H5E	17.144
FJ100P-2PB8B	\$ 2,520.00	H4E	17.142	FJ302-3BB6B	\$ 2,150.00	H4E	17.144	FJ400P-3MB4B	\$ 17,360.00	H5E	17.143
FJ100P-3MB8B	\$ 2,750.00	H4E	17.143	FJ302-3MB6B	\$ 1,650.00	H4E	17.143	FJ400P-3PB4B	\$ 8,400.00	H5E	17.143
FJ100P-3PB8B	\$ 2,800.00	H4E	17.143	FJ302-3PB6B	\$ 600.00	H4E	17.143	FJ400P-3TB4B	\$ 17,360.00	H5E	17.144
FJ100P-3TB8B	\$ 2,750.00	H4E	17.144	FJ302-3TB6B	\$ 1,650.00	H4E	17.144	FJ400P-4PB4B	\$ 10,500.00	H5E	17.142
FJ100P-4PB8B	\$ 3,500.00	H4E	17.142	FJ302-4PB6B	\$ 750.00	H4E	17.142	FJ400P-6PB8B	\$ 15,600.00	H5E	17.143
FJ100P-6PB4B	\$ 2,475.00	H4E	17.143	FJ302-6PB6B	\$ 1,480.00	H4E	17.143	FJ400X-2PB4B	\$ 9,720.00	H5E	17.142
FJ100X-2PB8B	\$ 3,420.00	H4E	17.142	FJ303-3BB8B	\$ 2,050.00	H4E	17.144	FJ400X-3B6B	\$ 42,500.00	H5E	17.144
FJ100X-3MB8B	\$ 5,500.00	H4E	17.143	FJ303-3MB6B	\$ 1,560.00	H4E	17.143	FJ400X-3MB4B	\$ 22,160.00	H5E	17.143
FJ100X-3PB8B	\$ 3,800.00	H4E	17.143	FJ303-3PB6B	\$ 600.00	H4E	17.143	FJ400X-3PB4B	\$ 10,800.00	H5E	17.143
FJ100X-3TB8B	\$ 5,500.00	H4E	17.144	FJ303-3TB6B	\$ 1,560.00	H4E	17.144	FJ400X-3TB4B	\$ 22,160.00	H5E	17.144
FJ100X-4PB8B	\$ 4,750.00	H4E	17.142	FJ303-4PB6B	\$ 750.00	H4E	17.142	FJ400X-4PB4B	\$ 13,500.00	H5E	17.142
FJ100X-6PB4B	\$ 7,820.00	H4E	17.143	FJ303-6PB6B	\$ 1,400.00	H4E	17.143	FJ400X-6PB8B	\$ 22,160.00	H5E	17.143
FJ2001-2PB4B	\$ 1,980.00	H5E	17.142	FJ304-3BB8B	\$ 3,150.00	H4E	17.144	FJ6001-2PB4B	\$ 4,770.00	H5E	17.142
FJ2001-3B6B	\$ 9,000.00	H5E	17.144	FJ304-3MB6B	\$ 2,400.00	H4E	17.143	FJ6001-3B6B	\$ 21,100.00	H5E	17.144
FJ2001-3MB4B	\$ 4,960.00	H5E	17.143	FJ304-3PB6B	\$ 1,100.00	H4E	17.143	FJ6001-3MB4B	\$ 11,160.00	H5E	17.143
FJ2001-3PB4B	\$ 2,200.00	H5E	17.143	FJ304-3TB6B	\$ 2,400.00	H4E	17.144	FJ6001-3PB4B	\$ 5,300.00	H5E	17.143
FJ2001-3TB4B	\$ 4,960.00	H5E	17.144	FJ304-4PB6B	\$ 1,375.00	H4E	17.142	FJ6001-3TB4B	\$ 11,160.00	H5E	17.144
FJ2001-4PB4B	\$ 2,750.00	H5E	17.142	FJ304-6PB6B	\$ 2,150.00	H4E	17.143	FJ6001-4PB4B	\$ 6,625.00	H5E	17.142
FJ2001-6P8B	\$ 4,450.00	H5E	17.143	FJ30P-3BB6B	\$ 2,250.00	H4E	17.144	FJ6001-6P8B	\$ 10,050.00	H5E	17.143
FJ2002-2PB8B	\$ 2,160.00	H5E	17.142	FJ30P-3MB6B	\$ 1,750.00	H4E	17.143	FJ6002-2PB4B	\$ 5,580.00	H5E	17.142
FJ2002-3B6B	\$ 9,800.00	H5E	17.144	FJ30P-3PB6B	\$ 1,040.00	H4E	17.143	FJ6002-3B6B	\$ 24,600.00	H5E	17.144
FJ2002-3MB4B	\$ 5,360.00	H5E	17.143	FJ30P-3TB6B	\$ 1,750.00	H4E	17.144	FJ6002-3MB4B	\$ 12,960.00	H5E	17.143
FJ2002-3PB4B	\$ 2,400.00	H5E	17.143	FJ30P-4PB6B	\$ 1,300.00	H4E	17.142	FJ6002-3PB4B	\$ 6,200.00	H5E	17.143
FJ2002-3TB4B	\$ 5,360.00	H5E	17.144	FJ30P-6PB6B	\$ 1,575.00	H4E	17.143	FJ6002-3TB4B	\$ 12,960.00	H5E	17.144
FJ2002-4PB4B	\$ 3,000.00	H5E	17.142	FJ30X-3BB8B	\$ 4,550.00	H4E	17.144	FJ6002-4PB4B	\$ 7,750.00	H5E	17.142
FJ2002-6PB8B	\$ 4,850.00	H5E	17.143	FJ30X-3MB6B	\$ 3,500.00	H4E	17.143	FJ6002-6P8B	\$ 11,600.00	H5E	17.143
FJ2003-2PB4B	\$ 2,160.00	H5E	17.142	FJ30X-3PB6B	\$ 1,400.00	H4E	17.143	FJ6003-2PB4B	\$ 6,120.00	H5E	17.142
FJ2003-3B6B	\$ 9,800.00	H5E	17.144	FJ30X-3TB6B	\$ 3,500.00	H4E	17.144	FJ6003-3B6B	\$ 27,000.00	H5E	17.144
FJ2003-3MB4B	\$ 5,360.00	H5E	17.143	FJ30X-4PB6B	\$ 1,750.00	H4E	17.142	FJ6003-3MB4B	\$ 14,460.00	H5E	17.143
FJ2003-3PB4B	\$ 2,400.00	H5E	17.143	FJ30X-6PB6B	\$ 3,020.00	H4E	17.143	FJ6003-3PB4B	\$ 6,800.00	H5E	17.143
FJ2003-3TB4B	\$ 5,360.00	H5E	17.144	FJ4001-2PB4B	\$ 3,420.00	H5E	17.142	FJ6003-3TB4B	\$ 14,460.00	H5E	17.144
FJ2003-4PB4B	\$ 3,000.00	H5E	17.142	FJ4001-3B6B	\$ 15,300.00	H5E	17.144	FJ6003-4PB4B	\$ 8,500.00	H5E	17.142
FJ2003-6P8B	\$ 4,850.00	H5E	17.143	FJ4001-3MB4B	\$ 8,160.00	H5E	17.143	FJ6003-6P8B	\$ 13,000.00	H5E	17.143
FJ2004-2PB4B	\$ 3,600.00	H5E	17.142	FJ4001-3PB4B	\$ 3,800.00	H5E	17.143	FJ6004-2PB4B	\$ 11,520.00	H5E	17.142
FJ2004-3B6B	\$ 16,000.00	H5E	17.144	FJ4001-3TB4B	\$ 8,160.00	H5E	17.144	FJ6004-3B6B	\$ 50,300.00	H5E	17.144
FJ2004-3MB4B	\$ 8,450.00	H5E	17.143	FJ4001-4PB4B	\$ 4,750.00	H5E	17.142	FJ6004-3MB4B	\$ 26,050.00	H5E	17.143
FJ2004-3PB4B	\$ 3,900.00	H5E	17.143	FJ4001-6P8B	\$ 7,350.00	H5E	17.143	FJ6004-3PB4B	\$ 11,000.00	H5E	17.143
FJ2004-3TB4B	\$ 8,450.00	H5E	17.144	FJ4002-2PB4B	\$ 3,780.00	H5E	17.142	FJ6004-3TB4B	\$ 26,050.00	H5E	17.144
FJ2004-4PB4B	\$ 5,000.00	H5E	17.142	FJ4002-3B6B	\$ 16,800.00	H5E	17.144	FJ6004-4PB4B	\$ 16,000.00	H5E	17.142
FJ2004-6P8B	\$ 7,600.00	H5E	17.143	FJ4002-3MB4B	\$ 8,960.00	H5E	17.143	FJ6004-6P8B	\$ 23,450.00	H5E	17.143
FJ200P-2PB4B	\$ 3,960.00	H5E	17.142	FJ4002-3PB4B	\$ 4,200.00	H5E	17.143	FJ600P-2PB4B	\$ 12,240.00	H5E	17.142
FJ200P-3B6B	\$ 17,600.00	H5E	17.144	FJ4002-3TB4B	\$ 8,960.00	H5E	17.144	FJ600P-3B6B	\$ 53,500.00	H5E	17.144
FJ200P-3MB4B	\$ 9,300.00	H5E	17.143	FJ4002-4PB4B	\$ 5,250.00	H5E	17.142	FJ600P-3MB4B	\$ 27,760.00	H5E	17.143
FJ200P-3PB4B	\$ 4,400.00	H5E	17.143	FJ4002-6PB8B	\$ 8,050.00	H5E	17.143	FJ600P-3PB4B	\$ 13,600.00	H5E	17.143
FJ200P-3TB4B	\$ 9,300.00	H5E	17.144	FJ4003-2PB4B	\$ 3,780.00	H5E	17.142	FJ600P-3TB4B	\$ 27,760.00	H5E	17.144
FJ200P-4PB4B	\$ 5,500.00	H5E	17.142	FJ4003-3B6B	\$ 16,800.00	H5E	17.144	FJ600P-4PB4B	\$ 17,000.00	H5E	17.142
FJ200P-6PB8B	\$ 8,350.00	H5E	17.143	FJ4003-3MB4B	\$ 8,960.00	H5E	17.143	FJ600P-6P8B	\$ 25,000.00	H5E	17.143
FJ200X-2PB4B	\$ 4,500.00	H5E	17.142	FJ4003-3PB4B	\$ 4,200.00	H5E	17.143	FJ600X-2PB4B	\$ 14,400.00	H5E	17.142
FJ200X-3B6B	\$ 19,950.00	H5E	17.144	FJ4003-3TB4B	\$ 8,960.00	H5E	17.144	FJ600X-3B6B	\$ 62,800.00	H5E	17.144
FJ200X-3MB4B	\$ 10,560.00	H5E	17.143	FJ4003-4PB4B	\$ 5,250.00	H5E	17.142	FJ600X-3MB4B	\$ 32,560.00	H5E	17.143
FJ200X-3PB4B	\$ 5,000.00	H5E	17.143	FJ4003-6P8B	\$ 8,050.00	H5E	17.143	FJ600X-3PB4B	\$ 16,000.00	H5E	17.143
FJ200X-3TB4B	\$ 10,560.00	H5E	17.144	FJ4004-2PB4B	\$ 7,775.00	H5E	17.142	FJ600X-3TB4B	\$ 32,560.00	H5E	17.144
FJ200X-4PB4B	\$ 6,250.00	H5E	17.142	FJ4004-3B6B	\$ 34,000.00	H5E	17.144	FJ600X-4PB4B	\$ 20,000.00	H5E	17.142
FJ200X-6P8B	\$ 10,560.00	H5E	17.143	FJ4004-3MB4B	\$ 17,730.00	H5E	17.143	FJ600X-6P8B	\$ 32,560.00	H5E	17.143
FJ301-3BB8B	\$ 1,850.00	H4E	17.144	FJ4004-3PB4B	\$ 7,700.00	H5E	17.143	FJ601-3MB6B	\$ 1,620.00	H4E	17.143
FJ301-3MB6B	\$ 1,420.00	H4E	17.143	FJ4004-3TB4B	\$ 17,730.00	H5E	17.144	FJ601-3PB6B	\$ 660.00	H4E	17.143
FJ301-3PB6B	\$ 560.00	H4E	17.143	FJ4004-4PB4B	\$ 10,800.00	H5E	17.142	FJ601-3TB8B	\$ 1,620.00	H4E	17.144
FJ301-3TB6B	\$ 1,420.00	H4E	17.144	FJ4004-6P8B	\$ 15,950.00	H5E	17.143	FJ601-4PB6B	\$ 825.00	H4E	17.142
FJ301-4PB6B	\$ 700.00	H4E	17.142	FJ400P-2PB4B	\$ 7,560.00	H5E	17.142	FJ601-6PB4B	\$ 1,450.00	H4E	17.143

FJ602-3MB6B – K4FHD-12S4

Catalog number	List price	Discount schedule	Page number	Catalog number	List price	Discount schedule	Page number	Catalog number	List price	Discount schedule	Page number
FJ602-3MB6B	\$ 2,020.00	H4E	17.143	FL800P-6P8B	\$ 31,800.00	H5E	17.143	K1PC	\$ 342.00	SA	15.63
FJ602-3PB6B	\$ 860.00	H4E	17.143	FL800X-2PB4B	\$ 18,900.00	H5E	17.142	K1PFC	\$ 171.00	SA	15.63
FJ602-3TB8B	\$ 2,020.00	H4E	17.144	FL800X-3B6B	\$ 82,300.00	H5E	17.144	K1PFR	\$ 207.00	SA	15.63
FJ602-4PB6B	\$ 1,075.00	H4E	17.142	FL800X-3PB4B	\$ 21,000.00	H5E	17.143	K1PMK	\$ 171.00	SA	15.63
FJ602-6PB4B	\$ 1,850.00	H4E	17.143	FL800X-3TB4B	\$ 42,560.00	H5E	17.144	K1PR	\$ 378.00	SA	15.63
FJ603-3MB6B	\$ 1,780.00	H4E	17.143	FL800X-4PB4B	\$ 26,250.00	H5E	17.142	K1S1	\$ 197.00	SA	15.54
FJ603-3PB6B	\$ 860.00	H4E	17.143	FL800X-6P8B	\$ 42,560.00	H5E	17.143	K1S2	\$ 197.00	SA	15.54
FJ603-3TB8B	\$ 1,780.00	H4E	17.144	FLSWM5X8AY	\$ 2.00	H6	17.11	K1S3	\$ 197.00	SA	15.54
FJ603-4PB6B	\$ 1,075.00	H4E	17.142	GA75-10-00-84	\$ 570.00	AA	1.126	K1S4	\$ 197.00	SA	15.54
FJ603-6PB4B	\$ 1,600.00	H4E	17.143	GAE75-10-00-81	\$ 675.00	AA	1.126	K1S5	\$ 197.00	SA	15.54
FJ604-3MB8B	\$ 2,750.00	H4E	17.143	GAE75-10-11-81	\$ 705.00	AA	1.126	K1S6	\$ 197.00	SA	15.54
FJ604-3PB8B	\$ 1,300.00	H4E	17.143	HK-W	\$ 36.00	MA	5.17	K1S7	\$ 197.00	SA	15.54
FJ604-3TB8B	\$ 2,750.00	H4E	17.144	HK1-02	\$ 33.00	MA	5.4	K1S8	\$ 197.00	SA	15.54
FJ604-4PB8B	\$ 1,800.00	H4E	17.142	HK1-11	\$ 33.00	MA	5.4	K1S9	\$ 197.00	SA	15.54
FJ604-6PB4B	\$ 2,450.00	H4E	17.143	HK1-20	\$ 33.00	MA	5.4	K2C-AB	\$ 15.00	SA	15.56
FJ60P-3MB8B	\$ 2,020.00	H4E	17.143	HK4-11	\$ 36.00	MA	5.17	K2C-SU	\$ 15.00	SA	15.54
FJ60P-3PB8B	\$ 1,300.00	H4E	17.143	HKF1-11	\$ 33.00	MA	5.4	K2FHD-12S12	\$ 240.00	SH	15.60
FJ60P-3TB8B	\$ 2,020.00	H4E	17.144	HKS4-02	\$ 36.00	MA	5.17	K2FHD-12S4	\$ 280.00	SH	15.60
FJ60P-4PB8B	\$ 1,625.00	H4E	17.142	HKS4-11	\$ 36.00	MA	5.17	K2FHD-17S12	\$ 248.00	SH	15.60
FJ60P-6PB4B	\$ 1,820.00	H4E	17.143	HKS4-20	\$ 36.00	MA	5.17	K2FHD-17S4	\$ 288.00	SH	15.60
FJ60X-3MB8B	\$ 4,050.00	H4E	17.143	IPM1B	\$ 28.00	RM	9.103	K2FHD-22S12	\$ 255.00	SH	15.60
FJ60X-3PB8B	\$ 1,800.00	H4E	17.143	IPM1G	\$ 28.00	RM	9.103	K2FHD-22S4	\$ 295.00	SH	15.60
FJ60X-3TB8B	\$ 4,050.00	H4E	17.144	IPM1R	\$ 28.00	RM	9.103	K2FHD-M	\$ 128.00	SH	15.60
FJ60X-4PB8B	\$ 2,250.00	H4E	17.142	IPM1Y	\$ 28.00	RM	9.103	K2FHDC-M	\$ 198.00	SH	15.61
FJ60X-6PB4B	\$ 3,820.00	H4E	17.143	IPM2B	\$ 28.00	RM	9.103	K2U1	\$ 197.00	SA	15.54
FJ8004-3PB4B	\$ 16,000.00	H5E	17.143	IPM2G	\$ 28.00	RM	9.103	K2U2	\$ 197.00	SA	15.54
FJ800X-3MB4B	\$ 42,560.00	H5E	17.143	IPM2R	\$ 28.00	RM	9.103	K2U3	\$ 197.00	SA	15.54
FL8001-2PB4B	\$ 8,550.00	H5E	17.142	IPM2Y	\$ 28.00	RM	9.103	K2U4	\$ 197.00	SA	15.54
FL8001-3B6B	\$ 37,500.00	H5E	17.144	IPS*1A11	\$ 76.00	RM	9.104	K2U5	\$ 197.00	SA	15.54
FL8001-3MB4B	\$ 19,560.00	H5E	17.143	IPS*1A22	\$ 88.00	RM	9.104	K2U6	\$ 197.00	SA	15.54
FL8001-3PB4B	\$ 9,500.00	H5E	17.143	IPS*1D11	\$ 76.00	RM	9.104	K2U7	\$ 197.00	SA	15.54
FL8001-3TB4B	\$ 19,560.00	H5E	17.144	IPS*1D22	\$ 88.00	RM	9.104	K2U8	\$ 197.00	SA	15.54
FL8001-4PB4B	\$ 11,875.00	H5E	17.142	IPS*2A11	\$ 83.00	RM	9.104	K2U9	\$ 197.00	SA	15.54
FL8001-6P8B	\$ 17,600.00	H5E	17.143	IPS*2A22	\$ 91.00	RM	9.104	K2VD-H	\$ 25.00	SH	15.59
FL8002-2PB4B	\$ 8,820.00	H5E	17.142	IPS*2D11	\$ 83.00	RM	9.104	K2VD-M	\$ 59.00	SH	15.59
FL8002-3B6B	\$ 38,700.00	H5E	17.144	IPS*2D22	\$ 91.00	RM	9.104	K3DMB	\$ 24.00	SA	15.62
FL8002-3MB4B	\$ 20,160.00	H5E	17.143	IPS*3A11	\$ 81.00	RM	9.104	K3FHD-12S12	\$ 240.00	SH	15.60
FL8002-3PB4B	\$ 9,800.00	H5E	17.143	IPS*3A22	\$ 93.00	RM	9.104	K3FHD-12S4	\$ 280.00	SH	15.60
FL8002-3TB4B	\$ 20,160.00	H5E	17.144	IPS*3D11	\$ 81.00	RM	9.104	K3FHD-17S12	\$ 248.00	SH	15.60
FL8002-4PB4B	\$ 12,250.00	H5E	17.142	IPS*3D22	\$ 93.00	RM	9.104	K3FHD-17S4	\$ 288.00	SH	15.60
FL8002-6P8B	\$ 18,150.00	H5E	17.143	IPSXCA11	\$ 17.00	RM	9.105	K3FHD-22S12	\$ 255.00	SH	15.60
FL8003-2PB4B	\$ 10,080.00	H5E	17.142	IPSXCD11	\$ 17.00	RM	9.105	K3FHD-22S4	\$ 295.00	SH	15.60
FL8003-3B6B	\$ 44,100.00	H5E	17.144	IPSXG	\$ 28.00	RM	9.105	K3FHD-M	\$ 128.00	SH	15.60
FL8003-3MB4B	\$ 22,960.00	H5E	17.143	IPSXR	\$ 28.00	RM	9.105	K3MI-H	\$ 570.00	SA	15.62
FL8003-3PB4B	\$ 11,200.00	H5E	17.143	IPSXY	\$ 28.00	RM	9.105	K3MI-V	\$ 570.00	SA	15.62
FL8003-3TB4B	\$ 22,960.00	H5E	17.144	IPSXZ	\$ 28.00	RM	9.105	K3PF	\$ 393.00	SA	15.63
FL8003-4PB4B	\$ 14,000.00	H5E	17.142	IPSZ1A11	\$ 85.00	RM	9.104	K3PFF	\$ 190.00	SA	15.63
FL8003-6P8B	\$ 20,600.00	H5E	17.143	IPSZ1A22	\$ 97.00	RM	9.104	K3PFR	\$ 230.00	SA	15.63
FL8004-2PB4B	\$ 15,120.00	H5E	17.142	IPSZ1D11	\$ 85.00	RM	9.104	K3PR	\$ 433.00	SA	15.63
FL8004-3B6B	\$ 65,800.00	H5E	17.144	IPSZ1D22	\$ 97.00	RM	9.104	K3TA	\$ 6.00	SA	15.34
FL8004-3MB4B	\$ 34,050.00	H5E	17.143	IPSZ3A11	\$ 90.00	RM	9.104	K3TA-2	\$ 4.00	SA	15.58
FL8004-3TB4B	\$ 34,050.00	H5E	17.144	IPSZ3A22	\$ 102.00	RM	9.104	K3WF	\$ 433.00	SA	15.63
FL8004-4PB4B	\$ 21,000.00	H5E	17.142	IPSZ3D11	\$ 90.00	RM	9.104	K3WFF	\$ 230.00	SA	15.63
FL8004-6P8B	\$ 30,650.00	H5E	17.143	IPSZ3D22	\$ 102.00	RM	9.104	K3WFR	\$ 270.00	SA	15.63
FL800P-2PB4B	\$ 15,660.00	H5E	17.142	K1AS	\$ 175.00	SA	15.56	K3WR	\$ 473.00	SA	15.63
FL800P-3B6B	\$ 73,500.00	H5E	17.144	K1BA	\$ 175.00	SA	15.56	K4DMB	\$ 26.00	SA	15.62
FL800P-3MB4B	\$ 35,360.00	H5E	17.143	K1DMB	\$ 11.00	SA	15.62	K4ET-250	\$ 46.00	SA	15.34
FL800P-3PB4B	\$ 17,400.00	H5E	17.143	K1LC	\$ 8.00	SA	15.62	K4FCT	\$ 72.00	SA	15.63
FL800P-3TB4B	\$ 35,360.00	H5E	17.144	K1LCH	\$ 16.00	SA	15.62	K4FHD-12S12	\$ 240.00	SH	15.60
FL800P-4PB4B	\$ 21,750.00	H5E	17.142	K1LD	\$ 14.00	SA	15.62	K4FHD-12S4	\$ 280.00	SH	15.60

K4FHD-17S12 – K7AS

Alphanumeric

0

Catalog number	List price	Discount schedule	Page number	Catalog number	List price	Discount schedule	Page number	Catalog number	List price	Discount schedule	Page number
K4FHD-17S12	\$ 248.00	SH	15.60	K5FHD-17S4	\$ 288.00	SH	15.60	K622-*	\$ 48.00	AA	4.9
K4FHD-17S4	\$ 288.00	SH	15.60	K5FHD-22S12	\$ 255.00	SH	15.60	K622FP-*	\$ 48.00	AA	4.9
K4FHD-22S12	\$ 255.00	SH	15.60	K5FHD-22S4	\$ 295.00	SH	15.60	K622SP-*	\$ 48.00	AA	4.9
K4FHD-22S4	\$ 295.00	SH	15.60	K5FHD-M	\$ 128.00	SH	15.60	K631-*	\$ 48.00	AA	4.9
K4FHD-M	\$ 128.00	SH	15.60	K5FPM	\$ 128.00	SH	15.61	K631FP-*	\$ 48.00	AA	4.9
K4FPM	\$ 110.00	SH	15.61	K5K2	\$ 415.00	SA	15.55	K631SP-*	\$ 48.00	AA	4.9
K4LC	\$ 8.00	SA	15.62	K5KL-EO	\$ 25.00	SA	15.62	K640-*	\$ 48.00	AA	4.9
K4LCH	\$ 16.00	SA	6.8	K5KL-EO-2	\$ 25.00	SA	15.62	K640FP-*	\$ 48.00	AA	4.9
K4MI-H	\$ 570.00	SA	15.62	K5LC	\$ 12.00	SA	15.62	K640SP-*	\$ 48.00	AA	4.9
K4MI-V	\$ 570.00	SA	15.62	K5LCH	\$ 24.00	SA	6.8	K6C-AB	\$ 15.00	SA	15.56
K4NCT-100	\$ 250.00	S4	15.38	K5LD	\$ 14.00	SA	15.62	K6C-ABP	\$ 15.00	SA	15.56
K4NCT-250	\$ 250.00	S4	15.38	K5LDW	\$ 14.00	SA	15.62	K6C-M	\$ 15.00	SA	15.57
K4PF	\$ 406.00	SA	15.63	K5M2	\$ 678.00	SA	15.57	K6C-MP	\$ 15.00	SA	15.57
K4PFF	\$ 203.00	SA	15.63	K5M4	\$ 678.00	SA	15.57	K6C-SU	\$ 15.00	SA	15.55
K4PFR	\$ 243.00	SA	15.63	K5M7	\$ 678.00	SA	15.57	K6C-SUP	\$ 15.00	SA	15.55
K4PMK	\$ 203.00	SA	15.63	K5M8	\$ 678.00	SA	15.57	K6ET-600	\$ 150.00	SA	15.46
K4PR	\$ 446.00	SA	15.63	K5MI-H	\$ 590.00	SA	15.62	K6ET-800	\$ 170.00	SA	15.46
K4RC	\$ 87.00	SA	15.63	K5MI-V	\$ 590.00	SA	15.62	K6FHD-12S12	\$ 523.00	SH	15.60
K4TB	\$ 6.00	SA	15.34	K5NCT-400	\$ 250.00	S5	15.42	K6FHD-12S4	\$ 563.00	SH	15.60
K4TB-2	\$ 4.00	SA	15.38	K5PF	\$ 516.00	SA	15.63	K6FHD-17S12	\$ 531.00	SH	15.60
K4TB-2C	\$ 8.00	SA	15.58	K5PFF	\$ 278.00	SA	15.63	K6FHD-22S12	\$ 538.00	SH	15.60
K4TBC	\$ 12.00	SA	15.58	K5PFR	\$ 278.00	SA	15.63	K6FHD-22S4	\$ 578.00	SH	15.60
K4TC	\$ 6.00	SA	15.34	K5PMK	\$ 238.00	SA	15.63	K6FHD-M	\$ 411.00	SH	15.60
K4TC-2	\$ 4.00	SA	15.38	K5PR	\$ 516.00	SA	15.63	K6FHDC-036	\$ 114.00	SH	15.61
K4TC-2C	\$ 8.00	SA	15.58	K5RC	\$ 225.00	SA	15.63	K6FHDC-060	\$ 146.00	SH	15.61
K4TCC	\$ 12.00	SA	15.58	K5RH	\$ 108.00	SH	15.59	K6FPM	\$ 220.00	SH	15.61
K4TD	\$ 15.00	SA	15.34	K5S1	\$ 415.00	SA	15.55	K6LC	\$ 18.00	SA	15.62
K4TD-2	\$ 10.00	SA	15.34	K5S4	\$ 415.00	SA	15.55	K6LC-S	\$ 5.00	SA	15.62
K4TD-2C	\$ 14.00	SA	15.58	K5S7	\$ 415.00	SA	15.55	K6LCH	\$ 32.00	SA	15.62
K4TDC	\$ 21.00	SA	15.58	K5S8	\$ 415.00	SA	15.55	K6LD	\$ 16.00	SA	15.62
K4TE	\$ 30.00	SA	15.38	K5S9	\$ 415.00	SA	15.55	K6LDW	\$ 16.00	SA	15.62
K4TE-2	\$ 20.00	SA	15.38	K5SA	\$ 415.00	SA	15.55	K6M2	\$ 2,407.00	SA	15.57
K4TE-2C	\$ 24.00	SA	15.58	K5SB	\$ 415.00	SA	15.55	K6M4	\$ 2,407.00	SA	15.57
K4TEC	\$ 36.00	SA	15.58	K5TF	\$ 45.00	SA	15.42	K6M7	\$ 2,407.00	SA	15.57
K4TER	\$ 30.00	SA	15.34	K5TF-2	\$ 30.00	SA	15.42	K6M8	\$ 2,407.00	SA	15.57
K4TES	\$ 30.00	SA	15.34	K5TF-2C	\$ 34.00	SA	15.58	K6MI-H	\$ 620.00	SA	15.62
K4TN	\$ 125.00	SA	15.58	K5TFC	\$ 51.00	SA	15.58	K6MI-V	\$ 620.00	SA	15.62
K4WF	\$ 486.00	SA	15.63	K5TG	\$ 45.00	SA	15.42	K6NCT-600	\$ 250.00	S6	15.46
K4WFF	\$ 283.00	SA	15.63	K5TG-2	\$ 30.00	S5	15.42	K6NCT-800	\$ 250.00	S6	15.46
K4WFR	\$ 323.00	SA	15.63	K5TG-2C	\$ 34.00	SA	15.58	K6RC	\$ 280.00	SA	15.63
K4WMK	\$ 203.00	SA	15.63	K5TGC	\$ 51.00	SA	15.58	K6RH	\$ 124.00	SH	15.59
K4WR	\$ 526.00	SA	15.63	K5TGD	\$ 240.00	SA	15.58	K6TH	\$ 75.00	SA	15.46
K5AS	\$ 260.00	SA	15.56	K5TGR	\$ 90.00	SA	15.42	K6TH-2	\$ 50.00	SA	15.46
K5BA	\$ 350.00	SA	15.56	K5TGS	\$ 90.00	SA	15.42	K6TH-2C	\$ 54.00	SA	15.58
K5C036	\$ 114.00	SH	15.61	K5U1	\$ 415.00	SA	15.55	K6THC	\$ 81.00	SA	15.58
K5C048	\$ 146.00	SH	15.61	K5U2	\$ 415.00	SA	15.55	K6THR	\$ 150.00	SA	15.46
K5C060	\$ 160.00	SH	15.61	K5U3	\$ 415.00	SA	15.55	K6TJ	\$ 135.00	SA	15.46
K5C072	\$ 175.00	SH	15.61	K5U4	\$ 415.00	SA	15.55	K6TJ-2	\$ 90.00	SA	15.46
K5C084	\$ 204.00	SH	15.61	K5U5	\$ 415.00	SA	15.55	K6TJ-2C	\$ 94.00	SA	15.58
K5C096	\$ 221.00	SH	15.61	K5U6	\$ 415.00	SA	15.55	K6TJC	\$ 141.00	SA	15.58
K5C108	\$ 238.00	SH	15.61	K5U7	\$ 415.00	SA	15.55	K6TJR	\$ 170.00	SA	15.46
K5C120	\$ 256.00	SH	15.61	K5U8	\$ 415.00	SA	15.55	K6VD-M	\$ 80.00	SH	15.59
K5DMB	\$ 38.00	SA	15.62	K5VD-H	\$ 25.00	SH	15.59	K6WF	\$ 1,869.00	SA	15.63
K5ET-400	\$ 114.00	SA	15.42	K5VD-LSS	\$ 25.00	SH	15.59	K6WFF	\$ 1,346.00	SA	15.63
K5FCH	\$ 213.00	SH	15.61	K5VD-M	\$ 49.00	SH	15.59	K6WFR-H	\$ 1,346.00	SA	15.63
K5FCH4	\$ 243.00	SH	15.61	K5VD-S12	\$ 24.00	SH	15.59	K6WFR-V	\$ 1,346.00	SA	15.63
K5FCT	\$ 86.00	SA	15.63	K5WF	\$ 596.00	SA	15.63	K6WMK	\$ 523.00	SA	15.63
K5FHD-12S12	\$ 240.00	SH	15.60	K5WFF	\$ 318.00	SA	15.63	K6WR-H	\$ 1,869.00	SA	15.63
K5FHD-12S4	\$ 280.00	SH	15.60	K5WFR	\$ 318.00	SA	15.63	K6WR-V	\$ 1,869.00	SA	15.63
K5FHD-17S12	\$ 248.00	SH	15.60	K5WMK	\$ 278.00	SA	15.63	K7AS	\$ 260.00	SA	15.56

K7BA – KE4NCT-2500

Catalog number	List price	Discount schedule	Page number	Catalog number	List price	Discount schedule	Page number	Catalog number	List price	Discount schedule	Page number
K7BA	\$ 350.00	SA	15.56	K7U6	\$ 415.00	SA	15.55	KCB-02	\$ 16.00	CA	8.40
K7BA-3	\$ 350.00	SA	15.56	K7U7	\$ 415.00	SA	15.55	KCB-02B	\$ 16.00	CA	8.41
K7C-AB	\$ 15.00	SA	15.56	K7U8	\$ 415.00	SA	15.55	KCB-11	\$ 16.00	CA	8.40
K7C-ABP	\$ 15.00	SA	15.56	K7VD-H	\$ 28.00	SH	15.59	KCB-11B	\$ 16.00	CA	8.41
K7C-M	\$ 15.00	SA	15.57	K7VD-M	\$ 80.00	SH	15.59	KCB-20	\$ 16.00	CA	8.40
K7C-MP	\$ 15.00	SA	15.57	K7VD-S20	\$ 27.00	SH	15.59	KCB-20B	\$ 16.00	CA	8.41
K7C-SU	\$ 15.00	SA	15.55	K7WCR	\$ 20.00	SA	15.63	KDH2R	\$ 200.00	SH	15.61
K7C-SUP	\$ 15.00	SA	15.55	K7WF	\$ 2,932.00	SA	15.63	KDH3R	\$ 225.00	SH	15.61
K7C048	\$ 190.00	SH	15.61	K7WFF	\$ 2,111.00	SA	15.63	KE1FHRVR	\$ 644.00	EX	16.31
K7C060	\$ 220.00	SH	15.61	K7WFR-H	\$ 2,111.00	SA	15.63	KE2CT1000	\$ 840.00	EX	16.29
K7C072	\$ 256.00	SH	15.61	K7WFR-V	\$ 2,111.00	SA	15.63	KE2CT1200	\$ 840.00	EX	16.29
K7C084	\$ 270.00	SH	15.61	K7WWMK	\$ 821.00	SA	15.63	KE2CT1250	\$ 840.00	EX	16.29
K7C096	\$ 320.00	SH	15.61	K7WR-H	\$ 2,932.00	SA	15.63	KE2CT1600	\$ 840.00	EX	16.29
K7C120	\$ 350.00	SH	15.61	K7WR-V	\$ 2,932.00	SA	15.63	KE2CT250	\$ 840.00	EX	16.29
K7DB	\$ 5.00	SA	15.62	K8FP	\$ 25.00	SA	15.53	KE2CT400	\$ 840.00	EX	16.29
K7ET-1250	\$ 240.00	SA	15.58	K8NCT-1600	\$ 888.00	SA	15.53	KE2CT800	\$ 840.00	EX	16.29
K7FCH	\$ 310.00	SH	15.61	K8NCT-2000	\$ 888.00	SA	15.53	KE2FHRVR	\$ 690.00	EX	16.31
K7FCH4	\$ 415.00	SH	15.61	K8NCT-2500	\$ 888.00	SA	15.53	KE2ML	\$ 145.00	EX	16.30
K7FHD-17S4	\$ 571.00	SH	15.60	K8RT2500	\$ 855.00	SA	15.53	KE2NCT-1000	\$ 406.00	EX	16.29
K7FHD-HS12	\$ 93.00	SH	15.61	K8TL	\$ 274.00	SA	15.53	KE2NCT-1200	\$ 406.00	EX	16.29
K7FHD-HS4	\$ 133.00	SH	15.61	K8TM	\$ 315.00	SA	15.53	KE2NCT-1250	\$ 406.00	EX	16.29
K7FHD-S12	\$ 19.00	SH	15.60	K9NCT-2500	\$ 888.00	S8	15.53	KE2NCT-1600	\$ 406.00	EX	16.29
K7FHD-S17	\$ 27.00	SH	15.60	KA450	\$ 15.00	MA	5.18	KE2NCT-250	\$ 406.00	EX	16.29
K7FHD-S22	\$ 34.00	SH	15.60	KA495	\$ 18.00	MA	5.18	KE2NCT-400	\$ 406.00	EX	16.29
K7FPM	\$ 220.00	SH	15.61	KA495C	\$ 21.00	MA	5.18	KE2NCT-800	\$ 406.00	EX	16.29
K7KL	\$ 25.00	SA	15.62	KA70-1001	\$ 23.00	CD	8.103	KE2PS3	\$ 753.00	EX	16.27
K7KL-2	\$ 25.00	SA	15.62	KA70-1002	\$ 65.00	CD	8.103	KE2PS4	\$ 753.00	EX	16.27
K7KL-EO	\$ 25.00	SA	15.62	KA70-1011	\$ 33.00	CD	8.103	KE3CT1000	\$ 1,090.00	EX	16.29
K7KL-EO-2	\$ 25.00	SA	15.62	KA70-1012	\$ 15.00	CD	8.103	KE3CT1200	\$ 1,090.00	EX	16.29
K7LC	\$ 40.00	SA	15.62	KA70-1013	\$ 32.00	CD	8.103	KE3CT1250	\$ 1,090.00	EX	16.29
K7LD	\$ 20.00	SA	15.62	KA70-1021	\$ 20.00	CD	8.103	KE3CT1600	\$ 1,090.00	EX	16.29
K7LDW	\$ 20.00	SA	15.62	KA70-1022	\$ 27.00	CD	8.103	KE3CT2000	\$ 1,090.00	EX	16.29
K7M2	\$ 2,407.00	SA	15.57	KA70-1031	\$ 20.00	CD	8.103	KE3CT250	\$ 1,090.00	EX	16.29
K7M4	\$ 2,407.00	SA	15.57	KA70-1032	\$ 20.00	CD	8.103	KE3CT2500	\$ 1,090.00	EX	16.29
K7M7	\$ 2,407.00	SA	15.57	KASI-4101	\$ 300.00	CD	8.103	KE3CT400	\$ 1,090.00	EX	16.29
K7M8	\$ 2,407.00	SA	15.57	KASI-4102	\$ 300.00	CD	8.103	KE3CT800	\$ 1,090.00	EX	16.29
K7MI-H	\$ 630.00	SA	15.62	KB70-1201	\$ 115.00	CD	8.103	KE3F25HRVR	\$ 790.00	EX	16.31
K7MI-V	\$ 630.00	SA	15.62	KB70-3001	\$ 95.00	CD	8.103	KE3FHRVR	\$ 790.00	EX	16.31
K7NCT-1000	\$ 250.00	S7	15.50	KB70-3101	\$ 115.00	CD	8.103	KE3ML	\$ 145.00	EX	16.30
K7NCT-1200	\$ 250.00	S7	15.50	KC622-*	\$ 54.00	AA	4.9	KE3NCT-1000	\$ 414.00	EX	16.29
K7RC	\$ 340.00	SA	15.63	KC622FP-*	\$ 54.00	AA	4.9	KE3NCT-1200	\$ 414.00	EX	16.29
K7RH	\$ 145.00	SH	15.59	KC622SP-*	\$ 54.00	AA	4.9	KE3NCT-1250	\$ 414.00	EX	16.29
K7S1	\$ 415.00	SA	15.55	KC631-*	\$ 54.00	AA	4.9	KE3NCT-1600	\$ 414.00	EX	16.29
K7S2	\$ 415.00	SA	15.55	KC631-1.4	\$ 59.00	AA	4.10	KE3NCT-2000	\$ 414.00	EX	16.29
K7S4	\$ 415.00	SA	15.55	KC631-2.4	\$ 59.00	AA	4.10	KE3NCT-250	\$ 414.00	EX	16.29
K7S7	\$ 415.00	SA	15.55	KC631FP-*	\$ 54.00	AA	4.9	KE3NCT-2500	\$ 414.00	EX	16.29
K7S8	\$ 415.00	SA	15.55	KC631FP-1.4	\$ 59.00	AA	4.10	KE3NCT-400	\$ 414.00	EX	16.29
K7S9	\$ 415.00	SA	15.55	KC631FP-2.4	\$ 59.00	AA	4.10	KE3NCT-800	\$ 414.00	EX	16.29
K7SA	\$ 415.00	SA	15.55	KC631SP-*	\$ 54.00	AA	4.9	KE3PS3	\$ 753.00	EX	16.27
K7SB	\$ 415.00	SA	15.55	KC631SP-1.4	\$ 59.00	AA	4.10	KE3PS4	\$ 753.00	EX	16.27
K7TK	\$ 180.00	SA	15.58	KC631SP-2.4	\$ 59.00	AA	4.10	KE4CT1600	\$ 1,640.00	EX	16.29
K7TK-2	\$ 120.00	SA	15.58	KC640-*	\$ 54.00	AA	4.9	KE4CT2000	\$ 1,640.00	EX	16.29
K7TK-2C	\$ 124.00	SA	15.58	KC640-1.4	\$ 59.00	AA	4.10	KE4CT2500	\$ 1,640.00	EX	16.29
K7TKC	\$ 186.00	SA	15.58	KC640-2.4	\$ 59.00	AA	4.10	KE4CT3600	\$ 1,640.00	EX	16.29
K7TUT	\$ 210.00	SA	15.63	KC640FP-*	\$ 54.00	AA	4.9	KE4CT4000	\$ 1,640.00	EX	16.29
K7U1	\$ 415.00	SA	15.55	KC640FP-1.4	\$ 59.00	AA	4.10	KE4FHRVR	\$ 1,664.00	EX	16.31
K7U2	\$ 415.00	SA	15.55	KC640FP-2.4	\$ 59.00	AA	4.10	KE4ML-3	\$ 145.00	EX	16.30
K7U3	\$ 415.00	SA	15.55	KC640SP-*	\$ 54.00	AA	4.9	KE4NCT-1600	\$ 414.00	EX	16.29
K7U4	\$ 415.00	SA	15.55	KC640SP-1.4	\$ 59.00	AA	4.10	KE4NCT-2000	\$ 414.00	EX	16.29
K7U5	\$ 415.00	SA	15.55	KC640SP-2.4	\$ 59.00	AA	4.10	KE4NCT-2500	\$ 414.00	EX	16.29

KE4NCT-3200 – KSB-203L

Alphanumeric

0

Catalog number	List price	Discount schedule	Page number	Catalog number	List price	Discount schedule	Page number	Catalog number	List price	Discount schedule	Page number
KE4NCT-3200	\$ 414.00	EX	16.29	KE6PG	\$ 48.00	EX	16.28	KL70-123L	\$ 155.00	CD	8.102
KE4NCT-3600	\$ 414.00	EX	16.29	KE6PL1	\$ 202.00	EX	16.28	KL70-123R	\$ 155.00	CD	8.102
KE4NCT-4000	\$ 414.00	EX	16.29	KE6PL2	\$ 202.00	EX	16.28	KL70-123Y	\$ 155.00	CD	8.102
KE4TC3200	\$ 1,640.00	EX	16.29	KE6PL3	\$ 202.00	EX	16.28	KL70-203C	\$ 165.00	CD	8.102
KE6A10	\$ 1,050.00	EX	16.27	KE6PL4	\$ 202.00	EX	16.28	KL70-203G	\$ 165.00	CD	8.102
KE6A15	\$ 1,507.00	EX	16.27	KE6PL5	\$ 202.00	EX	16.28	KL70-203L	\$ 165.00	CD	8.102
KE6A15-W	\$ 1,507.00	EX	16.27	KE6PLA	\$ 212.00	EX	16.28	KL70-203R	\$ 165.00	CD	8.102
KE6A4	\$ 297.00	EX	16.27	KE6PS1	\$ 377.00	EX	16.27	KL70-203Y	\$ 165.00	CD	8.102
KE6C0	\$ 374.00	EX	16.26	KE6PS2	\$ 753.00	EX	16.27	KL70-302C	\$ 100.00	CD	8.102
KE6C1	\$ 374.00	EX	16.26	KE6S0	\$ 374.00	EX	16.26	KL70-302G	\$ 100.00	CD	8.102
KE6C2	\$ 374.00	EX	16.26	KE6S0-2	\$ 456.00	EX	16.26	KL70-302L	\$ 100.00	CD	8.102
KE6C3	\$ 374.00	EX	16.26	KE6S1	\$ 374.00	EX	16.26	KL70-302R	\$ 100.00	CD	8.102
KE6C4	\$ 374.00	EX	16.26	KE6S1-2	\$ 456.00	EX	16.26	KL70-302Y	\$ 100.00	CD	8.102
KE6C5	\$ 374.00	EX	16.26	KE6S2	\$ 374.00	EX	16.26	KL70-305G	\$ 135.00	CD	8.102
KE6C6	\$ 374.00	EX	16.26	KE6S2-2	\$ 456.00	EX	16.26	KL70-305R	\$ 135.00	CD	8.102
KE6C7	\$ 374.00	EX	16.26	KE6S3	\$ 374.00	EX	16.26	KL70-305Y	\$ 135.00	CD	8.102
KE6C8	\$ 374.00	EX	16.26	KE6S3-2	\$ 456.00	EX	16.26	KL70-306G	\$ 140.00	CD	8.102
KE6C9	\$ 374.00	EX	16.26	KE6S4	\$ 374.00	EX	16.26	KL70-306R	\$ 140.00	CD	8.102
KE6CT3200	\$ 2,188.00	EX	16.29	KE6S4-2	\$ 456.00	EX	16.26	KL70-306Y	\$ 140.00	CD	8.102
KE6CT4000	\$ 2,188.00	EX	16.29	KE6S5	\$ 374.00	EX	16.26	KL70-307G	\$ 140.00	CD	8.102
KE6CT5000	\$ 2,188.00	EX	16.29	KE6S5-2	\$ 456.00	EX	16.26	KL70-307R	\$ 140.00	CD	8.102
KE6CT6300	\$ 2,188.00	EX	16.29	KE6S6	\$ 374.00	EX	16.26	KL70-307Y	\$ 140.00	CD	8.102
KE6DC	\$ 557.00	EX	16.31	KE6S6-2	\$ 456.00	EX	16.26	KL70-312C	\$ 100.00	CD	8.102
KE6FHRVR	\$ 2,783.00	EX	16.31	KE6S7	\$ 374.00	EX	16.26	KL70-312G	\$ 100.00	CD	8.102
KE6KKB-E2F	\$ 1,436.00	EX	16.31	KE6S7-2	\$ 456.00	EX	16.26	KL70-312L	\$ 100.00	CD	8.102
KE6KKB-E2W	\$ 1,195.00	EX	16.31	KE6S8	\$ 374.00	EX	16.26	KL70-312R	\$ 100.00	CD	8.102
KE6KKB-E3F	\$ 1,436.00	EX	16.31	KE6S8-2	\$ 456.00	EX	16.26	KL70-312Y	\$ 100.00	CD	8.102
KE6KKB-E3W	\$ 1,195.00	EX	16.31	KE6S9	\$ 374.00	EX	16.26	KL70-322C	\$ 100.00	CD	8.102
KE6KKB-E4F	\$ 1,436.00	EX	16.31	KE6S9-2	\$ 456.00	EX	16.26	KL70-322G	\$ 100.00	CD	8.102
KE6KKB-E4F-F	\$ 1,436.00	EX	16.31	KE6SC	\$ 73.00	EX	16.26	KL70-322L	\$ 100.00	CD	8.102
KE6KKB-E4W	\$ 1,195.00	EX	16.31	KE6SP	\$ 43.00	EX	16.28	KL70-322R	\$ 100.00	CD	8.102
KE6KKB-E4W-4	\$ 1,195.00	EX	16.31	KE6TBA	\$ 348.00	EX	16.26	KL70-322Y	\$ 100.00	CD	8.102
KE6KKB-E6F	\$ 1,436.00	EX	16.31	KE6TL3	\$ 428.00	EX	16.31	KL70-401C	\$ 36.00	CD	8.102
KE6KKB-E6F-4	\$ 1,436.00	EX	16.31	KE6TL5	\$ 428.00	EX	16.31	KL70-401G	\$ 36.00	CD	8.102
KE6KKB-E6W	\$ 1,195.00	EX	16.31	KE6TL7	\$ 428.00	EX	16.31	KL70-401L	\$ 36.00	CD	8.102
KE6KKB-E6W-4	\$ 1,195.00	EX	16.31	KE6TL8	\$ 428.00	EX	16.31	KL70-401R	\$ 36.00	CD	8.102
KE6KL1	\$ 202.00	EX	16.28	KE6TL9	\$ 428.00	EX	16.31	KL70-401Y	\$ 36.00	CD	8.102
KE6KL2	\$ 202.00	EX	16.28	KE6TSM	\$ 188.00	EX	16.26	KLB1	\$ 8.00	CD	8.102
KE6KL3	\$ 202.00	EX	16.28	KE6U0	\$ 456.00	EX	16.27	KLB2	\$ 8.00	CD	8.102
KE6KL4	\$ 202.00	EX	16.28	KE6U1	\$ 456.00	EX	16.27	KLB24	\$ 8.00	CD	8.102
KE6KL5	\$ 202.00	EX	16.28	KE6U2	\$ 456.00	EX	16.27	KPR3-104B	\$ 14.00	CA	8.23
KE6M3	\$ 1,613.00	EX	16.26	KE6U3	\$ 456.00	EX	16.27	KPR3-104BMR	\$ 29.00	CA	8.23
KE6M5	\$ 1,613.00	EX	16.26	KE6U4	\$ 456.00	EX	16.27	KS70-1104	\$ 155.00	CD	8.103
KE6M7	\$ 1,613.00	EX	16.26	KE6U5	\$ 456.00	EX	16.27	KS70-1204	\$ 155.00	CD	8.103
KE6M9	\$ 1,613.00	EX	16.26	KE6U6	\$ 456.00	EX	16.27	KS70-2002	\$ 100.00	CD	8.103
KE6MC	\$ 418.00	EX	16.27	KE6U7	\$ 456.00	EX	16.27	KS70-2004	\$ 145.00	CD	8.103
KE6ML-3	\$ 145.00	EX	16.30	KE6U8	\$ 456.00	EX	16.27	KS70-3004	\$ 145.00	CD	8.103
KE6ML-4	\$ 145.00	EX	16.30	KE6U9	\$ 456.00	EX	16.27	KSB-113C	\$ 155.00	CD	8.104
KE6MLA	\$ 628.00	EX	16.30	KE6UE01	\$ 82.00	EX	16.27	KSB-113G	\$ 155.00	CD	8.104
KE6MLC	\$ 628.00	EX	16.30	KE6UE10	\$ 82.00	EX	16.27	KSB-113L	\$ 155.00	CD	8.104
KE6MLC-VA	\$ 97.00	EX	16.30	KH210-*	\$ 100.00	AB	1.27	KSB-113R	\$ 155.00	CD	8.104
KE6MLC-VB	\$ 193.00	EX	16.30	KH300-*	\$ 120.00	AB	1.27	KSB-113Y	\$ 155.00	CD	8.104
KE6MLC-VC	\$ 193.00	EX	16.30	KH800-*	\$ 290.00	AB	1.27	KSB-123C	\$ 155.00	CD	8.104
KE6MLC-VD	\$ 193.00	EX	16.30	KL70-113C	\$ 155.00	CD	8.102	KSB-123G	\$ 155.00	CD	8.104
KE6MLP	\$ 241.00	EX	16.30	KL70-113G	\$ 155.00	CD	8.102	KSB-123L	\$ 155.00	CD	8.104
KE6NCT-3200	\$ 414.00	EX	16.29	KL70-113L	\$ 155.00	CD	8.102	KSB-123R	\$ 155.00	CD	8.104
KE6NCT-4000	\$ 414.00	EX	16.29	KL70-113R	\$ 155.00	CD	8.102	KSB-123Y	\$ 155.00	CD	8.104
KE6NCT-5000	\$ 414.00	EX	16.29	KL70-113Y	\$ 155.00	CD	8.102	KSB-203C	\$ 180.00	CD	8.104
KE6NCT-6300	\$ 414.00	EX	16.29	KL70-123C	\$ 155.00	CD	8.102	KSB-203G	\$ 180.00	CD	8.104
KE6PD1	\$ 162.00	EX	16.28	KL70-123G	\$ 155.00	CD	8.102	KSB-203L	\$ 180.00	CD	8.104

KSB-203R – LS35P41C11

Catalog number	List price	Discount schedule	Page number	Catalog number	List price	Discount schedule	Page number	Catalog number	List price	Discount schedule	Page number
KSB-203R	\$ 180.00	CD	8.104	KT3PMK	\$ 190.00	SAT	15.140	LS35P13B11	\$ 25.00	RM	9.7
KSB-203Y	\$ 180.00	CD	8.104	KT3R-3	\$ 98.00	SA	15.139	LS35P13B02-R	\$ 41.00	RM	9.90
KSB-305G	\$ 190.00	CD	8.104	KT3R-4	\$ 131.00	SA	15.139	LS35P13C11	\$ 27.00	RM	9.7
KSB-305R	\$ 190.00	CD	8.104	KT3RH	\$ 146.00	H6	15.139	LS35P13D11	\$ 26.00	RM	9.7
KSB-305Y	\$ 190.00	CD	8.104	KT3S1	\$ 298.00	SAT	15.138	LS35P13D11-R	\$ 41.00	RM	9.90
KSB-306G	\$ 195.00	CD	8.104	KT3S2	\$ 298.00	SAT	15.138	LS35P13L02	\$ 27.00	RM	9.7
KSB-306R	\$ 195.00	CD	8.104	KT3S3	\$ 298.00	SAT	15.138	LS35P13L02-R	\$ 41.00	RM	9.90
KSB-306Y	\$ 195.00	CD	8.104	KT3S4	\$ 298.00	SAT	15.138	LS35P13L20	\$ 27.00	RM	9.7
KSB-307G	\$ 195.00	CD	8.104	KT3S7	\$ 298.00	SAT	15.138	LS35P15B02	\$ 34.00	RM	9.60
KSB-307R	\$ 195.00	CD	8.104	KT3S8	\$ 298.00	SAT	15.138	LS35P15B11	\$ 31.00	RM	9.60
KSB-307Y	\$ 195.00	CD	8.104	KT3S9	\$ 298.00	SAT	15.138	LS35P15C11	\$ 34.00	RM	9.60
KSB-401C	\$ 55.00	CD	8.104	KT3U1	\$ 298.00	SAT	15.138	LS35P15D11	\$ 33.00	RM	9.60
KSB-401G	\$ 55.00	CD	8.104	KT3U2	\$ 298.00	SAT	15.138	LS35P15L02	\$ 34.00	RM	9.60
KSB-401L	\$ 55.00	CD	8.104	KT3U3	\$ 298.00	SAT	15.138	LS35P15L20	\$ 34.00	RM	9.60
KSB-401R	\$ 55.00	CD	8.104	KT3U4	\$ 298.00	SAT	15.138	LS35P16B02	\$ 36.00	RM	9.60
KSB-401Y	\$ 55.00	CD	8.104	KT3U5	\$ 298.00	SAT	15.138	LS35P16B11	\$ 33.00	RM	9.60
KSBB1	\$ 8.00	CD	8.104	KT3U7	\$ 298.00	SAT	15.138	LS35P16C11	\$ 36.00	RM	9.60
KSBB2	\$ 8.00	CD	8.104	KT3U8	\$ 298.00	SAT	15.138	LS35P16D11	\$ 35.00	RM	9.60
KSSB12	\$ 8.00	CD	8.104	KT3VD-H	\$ 87.00	H6	15.139	LS35P16L02	\$ 36.00	RM	9.60
KSSB24	\$ 8.00	CD	8.104	KT3VD-M	\$ 72.00	H6	15.139	LS35P16L20	\$ 36.00	RM	9.60
KT1HTC-3	\$ 37.00	SAT	15.140	KT3VD-S	\$ 35.00	H6	15.139	LS35P30B02	\$ 26.00	RM	9.7
KT1HTC-4	\$ 50.00	SAT	15.140	KT70-1001	\$ 40.00	CD	8.103	LS35P30B11	\$ 24.00	RM	9.7
KT1LTC-3	\$ 35.00	SAT	15.140	KT70-1002	\$ 40.00	CD	8.103	LS35P30C11	\$ 26.00	RM	9.7
KT1LTC-4	\$ 47.00	SAT	15.140	L45M43B02	\$ 58.00	RM	9.38	LS35P30D11	\$ 25.00	RM	9.7
KT2100-2	\$ 6.00	SAT	15.139	LB6	\$ 15.00	AA	4.11	LS35P30L02	\$ 26.00	RM	9.7
KT2100-3	\$ 9.00	SAT	15.139	LB6-CA	\$ 8.00	AA	4.11	LS35P30L20	\$ 26.00	RM	9.7
KT2100-4	\$ 12.00	SAT	15.139	LC26-B1	\$ 6.00	TAA	2.7	LS35P31B02	\$ 27.00	RM	9.7
KT2DIN	\$ 33.00	SAT	15.140	LC30-T	\$ 6.00	TAA	2.7	LS35P31B11	\$ 25.00	RM	9.7
KT2EF-3	\$ 26.00	SA	15.139	LD-110	\$ 30.00	ABA	1.29	LS35P31B02-R	\$ 43.00	RM	9.91
KT2EF-4	\$ 35.00	SA	15.139	LD-16	\$ 20.00	ABA	1.29	LS35P31C11	\$ 27.00	RM	9.7
KT2HTC-3	\$ 43.00	SAT	15.140	LD-26	\$ 22.00	ABA	1.29	LS35P31D11	\$ 26.00	RM	9.7
KT2HTC-4	\$ 58.00	SAT	15.140	LD-40	\$ 26.00	ABA	1.29	LS35P31D11-R	\$ 43.00	RM	9.91
KT2LTC-3	\$ 40.00	SAT	15.140	LD-75	\$ 28.00	ABA	1.29	LS35P31L02	\$ 27.00	RM	9.7
KT2PFF	\$ 238.00	SAT	15.140	LF75	\$ 40.00	ABA	1.3	LS35P31L02-R	\$ 43.00	RM	9.91
KT2PMK	\$ 171.00	SAT	15.140	LK110	\$ 23.00	ABA	1.17	LS35P31L20	\$ 27.00	RM	9.7
KT2R-3	\$ 78.00	SA	15.139	LK75-A	\$ 15.00	ABA	1.17	LS35P32B02	\$ 26.00	RM	9.7
KT2R-4	\$ 105.00	SA	15.139	LK75-A1	\$ 15.00	ABA	1.17	LS35P32B02-R	\$ 43.00	RM	9.91
KT3060-3	\$ 9.00	SAT	15.139	LP185	\$ 35.00	ABA	1.3	LS35P32B11	\$ 24.00	RM	9.7
KT3060-4	\$ 12.00	SAT	15.139	LP300	\$ 50.00	ABA	1.3	LS35P32C11	\$ 26.00	RM	9.7
KT3100-3	\$ 9.00	SAT	15.139	LP460	\$ 50.00	ABA	1.3	LS35P32D11	\$ 25.00	RM	9.7
KT3100-4	\$ 12.00	SAT	15.139	LP750	\$ 50.00	ABA	1.3	LS35P32D11-R	\$ 43.00	RM	9.91
KT3150-3	\$ 12.00	SAT	15.139	LS35P10B02	\$ 24.00	RM	9.60	LS35P32L02	\$ 26.00	RM	9.7
KT3150-4	\$ 18.00	SAT	15.139	LS35P10B11	\$ 22.00	RM	9.60	LS35P32L02-R	\$ 43.00	RM	9.91
KT3225-3	\$ 18.00	SAT	15.139	LS35P10C11	\$ 24.00	RM	9.60	LS35P32L20	\$ 26.00	RM	9.7
KT3225-4	\$ 24.00	SAT	15.139	LS35P10D11	\$ 23.00	RM	9.60	LS35P34B02	\$ 27.00	RM	9.7
KT3AS	\$ 190.00	SAT	15.138	LS35P10L02	\$ 24.00	RM	9.60	LS35P34B11	\$ 25.00	RM	9.7
KT3AS3	\$ 247.00	SAT	15.138	LS35P10L20	\$ 24.00	RM	9.60	LS35P34C11	\$ 27.00	RM	9.7
KT3DIN	\$ 41.00	SAT	15.140	LS35P11B02	\$ 24.00	RM	9.60	LS35P34D11	\$ 26.00	RM	9.7
KT3EF-3	\$ 33.00	SA	15.139	LS35P11B02-R	\$ 39.00	RM	9.90	LS35P34L02	\$ 27.00	RM	9.7
KT3EF-4	\$ 44.00	SA	15.139	LS35P11B11	\$ 22.00	RM	9.60	LS35P34L20	\$ 27.00	RM	9.7
KT3HTC-3	\$ 53.00	SAT	15.140	LS35P11C11	\$ 24.00	RM	9.60	LS35P40B02	\$ 25.00	RM	9.12
KT3HTC-4	\$ 72.00	SAT	15.140	LS35P11D11	\$ 23.00	RM	9.60	LS35P40B11	\$ 23.00	RM	9.12
KT3LD	\$ 21.00	SAT	15.139	LS35P11D11-R	\$ 39.00	RM	9.90	LS35P40C11	\$ 25.00	RM	9.12
KT3LTC-3	\$ 50.00	SAT	15.140	LS35P11L02	\$ 24.00	RM	9.60	LS35P40D11	\$ 24.00	RM	9.12
KT3LTC-4	\$ 68.00	SAT	15.140	LS35P11L02-R	\$ 39.00	RM	9.90	LS35P40L02	\$ 25.00	RM	9.12
KT3M1	\$ 645.00	SAT	15.138	LS35P11L20	\$ 24.00	RM	9.60	LS35P40L20	\$ 25.00	RM	9.12
KT3M2	\$ 645.00	SAT	15.138	LS35P12B02-R	\$ 43.00	RM	9.90	LS35P41B02	\$ 28.00	RM	9.8
KT3MIF2	\$ 452.00	SAT	15.140	LS35P12D11-R	\$ 43.00	RM	9.90	LS35P41B02-R	\$ 43.00	RM	9.91
KT3MIF3	\$ 904.00	SAT	15.140	LS35P12L02-R	\$ 43.00	RM	9.90	LS35P41B11	\$ 26.00	RM	9.8
KT3PFF	\$ 264.00	SAT	15.140	LS35P13B02	\$ 27.00	RM	9.7	LS35P41C11	\$ 28.00	RM	9.8

LS35P41D11 – LS45M61D11

Alphanumeric

0

Catalog number	List price	Discount schedule	Page number	Catalog number	List price	Discount schedule	Page number	Catalog number	List price	Discount schedule	Page number
LS35P41D11	\$ 27.00	RM	9.8	LS35P91L02	\$ 27.00	RM	9.9	LS45M32B11	\$ 50.00	RM	9.37
LS35P41D11-R	\$ 43.00	RM	9.91	LS35P91L20	\$ 27.00	RM	9.9	LS45M32C11	\$ 55.00	RM	9.37
LS35P41L02	\$ 28.00	RM	9.8	LS35P92B11	\$ 25.00	RM	9.9	LS45M32D11	\$ 53.00	RM	9.37
LS35P41L02-R	\$ 43.00	RM	9.91	LS35P92B02	\$ 27.00	RM	9.9	LS45M32L02	\$ 55.00	RM	9.37
LS35P41L20	\$ 28.00	RM	9.8	LS35P92C11	\$ 27.00	RM	9.9	LS45M32L20	\$ 55.00	RM	9.37
LS35P42B02	\$ 30.00	RM	9.8	LS35P92D11	\$ 27.00	RM	9.9	LS45M33B02	\$ 50.00	RM	9.38
LS35P42B11	\$ 27.00	RM	9.8	LS35P92L02	\$ 27.00	RM	9.9	LS45M33B11	\$ 45.00	RM	9.38
LS35P42C11	\$ 30.00	RM	9.8	LS35P92L20	\$ 27.00	RM	9.9	LS45M33C11	\$ 50.00	RM	9.38
LS35P42D11	\$ 29.00	RM	9.8	LS44M53B02	\$ 61.00	RM	9.39	LS45M33D11	\$ 49.00	RM	9.38
LS35P42L02	\$ 30.00	RM	9.8	LS44M53L20	\$ 61.00	RM	9.39	LS45M33L02	\$ 50.00	RM	9.38
LS35P42L20	\$ 30.00	RM	9.8	LS44M92B02	\$ 47.00	RM	9.41	LS45M33L20	\$ 50.00	RM	9.38
LS35P50B11	\$ 23.00	RM	9.13	LS45M00B02	\$ 30.00	RM	9.45	LS45M41B02	\$ 55.00	RM	9.38
LS35P50B02	\$ 25.00	RM	9.13	LS45M00B11	\$ 28.00	RM	9.45	LS45M41B11	\$ 50.00	RM	9.38
LS35P50C11	\$ 25.00	RM	9.13	LS45M00C11	\$ 30.00	RM	9.45	LS45M41C11	\$ 55.00	RM	9.38
LS35P50D11	\$ 24.00	RM	9.13	LS45M00D11	\$ 29.00	RM	9.45	LS45M41D11	\$ 53.00	RM	9.38
LS35P50L02	\$ 25.00	RM	9.13	LS45M00L02	\$ 30.00	RM	9.45	LS45M41L02	\$ 55.00	RM	9.38
LS35P50L20	\$ 25.00	RM	9.13	LS45M00L20	\$ 30.00	RM	9.45	LS45M41L20	\$ 55.00	RM	9.38
LS35P51B02	\$ 29.00	RM	9.8	LS45M11B02	\$ 42.00	RM	9.36	LS45M42B02	\$ 63.00	RM	9.38
LS35P51B11	\$ 27.00	RM	9.8	LS45M11B11	\$ 38.00	RM	9.36	LS45M42B11	\$ 57.00	RM	9.38
LS35P51C11	\$ 29.00	RM	9.8	LS45M11C11	\$ 42.00	RM	9.36	LS45M42C11	\$ 63.00	RM	9.38
LS35P51D11	\$ 28.00	RM	9.8	LS45M11D11	\$ 41.00	RM	9.36	LS45M42D11	\$ 61.00	RM	9.38
LS35P51L02	\$ 29.00	RM	9.8	LS45M11L02	\$ 42.00	RM	9.36	LS45M42L02	\$ 63.00	RM	9.38
LS35P51L20	\$ 29.00	RM	9.8	LS45M11L20	\$ 42.00	RM	9.36	LS45M42L20	\$ 63.00	RM	9.38
LS35P52B02	\$ 30.00	RM	9.8	LS45M12B02	\$ 45.00	RM	9.36	LS45M43B11	\$ 53.00	RM	9.38
LS35P52B11	\$ 28.00	RM	9.8	LS45M12B11	\$ 41.00	RM	9.36	LS45M43C11	\$ 58.00	RM	9.39
LS35P52C11	\$ 30.00	RM	9.8	LS45M12C11	\$ 45.00	RM	9.36	LS45M43D11	\$ 57.00	RM	9.39
LS35P52D11	\$ 30.00	RM	9.8	LS45M12D11	\$ 44.00	RM	9.36	LS45M43L02	\$ 58.00	RM	9.38
LS35P52L02	\$ 30.00	RM	9.8	LS45M12L02	\$ 45.00	RM	9.36	LS45M43L20	\$ 58.00	RM	9.38
LS35P52L20	\$ 30.00	RM	9.8	LS45M12L20	\$ 45.00	RM	9.36	LS45M44B02	\$ 57.00	RM	9.39
LS35P71B02	\$ 29.00	RM	9.9	LS45M13B02	\$ 49.00	RM	9.36	LS45M44B11	\$ 51.00	RM	9.39
LS35P71B11	\$ 27.00	RM	9.9	LS45M13B11	\$ 44.00	RM	9.36	LS45M44C11	\$ 57.00	RM	9.39
LS35P71C11	\$ 29.00	RM	9.9	LS45M13C11	\$ 49.00	RM	9.36	LS45M44D11	\$ 55.00	RM	9.39
LS35P71D11	\$ 28.00	RM	9.9	LS45M13D11	\$ 48.00	RM	9.36	LS45M44L02	\$ 57.00	RM	9.39
LS35P71L02	\$ 29.00	RM	9.9	LS45M13L02	\$ 49.00	RM	9.36	LS45M44L20	\$ 57.00	RM	9.39
LS35P71L20	\$ 29.00	RM	9.9	LS45M13L20	\$ 49.00	RM	9.36	LS45M51B02	\$ 57.00	RM	9.39
LS35P72B02	\$ 29.00	RM	9.9	LS45M21B02	\$ 45.00	RM	9.36	LS45M51B11	\$ 51.00	RM	9.39
LS35P72B11	\$ 27.00	RM	9.9	LS45M21B11	\$ 41.00	RM	9.36	LS45M51C11	\$ 57.00	RM	9.39
LS35P72C11	\$ 29.00	RM	9.9	LS45M21C11	\$ 45.00	RM	9.36	LS45M51D11	\$ 55.00	RM	9.39
LS35P72D11	\$ 28.00	RM	9.9	LS45M21D11	\$ 44.00	RM	9.36	LS45M51L02	\$ 57.00	RM	9.39
LS35P72L02	\$ 29.00	RM	9.9	LS45M21L02	\$ 45.00	RM	9.36	LS45M51L20	\$ 57.00	RM	9.39
LS35P72L20	\$ 29.00	RM	9.9	LS45M21L20	\$ 45.00	RM	9.36	LS45M52B02	\$ 65.00	RM	9.39
LS35P75C11-S	\$ 51.00	RM	9.78	LS45M22B02	\$ 50.00	RM	9.37	LS45M52B11	\$ 59.00	RM	9.39
LS35P75D11-S	\$ 51.00	RM	9.78	LS45M22B11	\$ 45.00	RM	9.37	LS45M52C11	\$ 65.00	RM	9.39
LS35P75L02-S	\$ 51.00	RM	9.78	LS45M22C11	\$ 50.00	RM	9.37	LS45M52D11	\$ 63.00	RM	9.39
LS35P76C11-S	\$ 57.00	RM	9.78	LS45M22D11	\$ 48.00	RM	9.37	LS45M52L02	\$ 65.00	RM	9.39
LS35P76D11-S	\$ 57.00	RM	9.78	LS45M22L02	\$ 50.00	RM	9.37	LS45M52L20	\$ 65.00	RM	9.39
LS35P76L02-S	\$ 57.00	RM	9.78	LS45M22L20	\$ 50.00	RM	9.37	LS45M53B11	\$ 55.00	RM	9.39
LS35P77C11-S	\$ 52.00	RM	9.79	LS45M23B02	\$ 50.00	RM	9.37	LS45M53C11	\$ 61.00	RM	9.39
LS35P77D11-S	\$ 52.00	RM	9.79	LS45M23B11	\$ 45.00	RM	9.37	LS45M53D11	\$ 59.00	RM	9.39
LS35P77L02-S	\$ 52.00	RM	9.79	LS45M23C11	\$ 50.00	RM	9.37	LS45M53L02	\$ 61.00	RM	9.39
LS35P80C11-S	\$ 43.00	RM	9.69	LS45M23D11	\$ 48.00	RM	9.37	LS45M54B02	\$ 58.00	RM	9.40
LS35P80D11-S	\$ 43.00	RM	9.68	LS45M23L02	\$ 50.00	RM	9.37	LS45M54B11	\$ 53.00	RM	9.40
LS35P80L02-S	\$ 43.00	RM	9.68	LS45M23L20	\$ 50.00	RM	9.37	LS45M54C11	\$ 58.00	RM	9.40
LS35P81C11-S	\$ 52.00	RM	9.72	LS45M31B02	\$ 47.00	RM	9.37	LS45M54D11	\$ 57.00	RM	9.40
LS35P81D11-S	\$ 52.00	RM	9.72	LS45M31B11	\$ 43.00	RM	9.37	LS45M54L02	\$ 58.00	RM	9.40
LS35P81L02-S	\$ 52.00	RM	9.72	LS45M31C11	\$ 47.00	RM	9.37	LS45M54L20	\$ 58.00	RM	9.40
LS35P91B02	\$ 27.00	RM	9.9	LS45M31D11	\$ 46.00	RM	9.37	LS45M61B02	\$ 55.00	RM	9.40
LS35P91B11	\$ 25.00	RM	9.9	LS45M31L02	\$ 47.00	RM	9.37	LS45M61B11	\$ 50.00	RM	9.40
LS35P91C11	\$ 27.00	RM	9.9	LS45M31L20	\$ 47.00	RM	9.37	LS45M61C11	\$ 55.00	RM	9.40
LS35P91D11	\$ 27.00	RM	9.9	LS45M32B02	\$ 55.00	RM	9.37	LS45M61D11	\$ 53.00	RM	9.40

LS45M61L02 – LS65M11L02

Catalog number	List price	Discount schedule	Page number	Catalog number	List price	Discount schedule	Page number	Catalog number	List price	Discount schedule	Page number
LS45M61L02	\$ 55.00	RM	9.40	LS45P13L20	\$ 40.00	RM	9.14	LS45P53L20	\$ 47.00	RM	9.16
LS45M61L20	\$ 55.00	RM	9.40	LS45P31B02	\$ 37.00	RM	9.14	LS45P54B02	\$ 45.00	RM	9.16
LS45M62B02	\$ 55.00	RM	9.40	LS45P31B11	\$ 34.00	RM	9.14	LS45P54B11	\$ 41.00	RM	9.16
LS45M62B11	\$ 50.00	RM	9.40	LS45P31C11	\$ 37.00	RM	9.14	LS45P54C11	\$ 45.00	RM	9.16
LS45M62C11	\$ 55.00	RM	9.40	LS45P31D11	\$ 36.00	RM	9.14	LS45P54D11	\$ 44.00	RM	9.16
LS45M62D11	\$ 53.00	RM	9.40	LS45P31L02	\$ 37.00	RM	9.14	LS45P54L02	\$ 45.00	RM	9.16
LS45M62L02	\$ 55.00	RM	9.40	LS45P31L20	\$ 37.00	RM	9.14	LS45P54L20	\$ 45.00	RM	9.16
LS45M62L20	\$ 55.00	RM	9.40	LS45P32B02	\$ 43.00	RM	9.15	LS45P61B02	\$ 46.00	RM	9.17
LS45M71B02	\$ 53.00	RM	9.40	LS45P32B11	\$ 39.00	RM	9.15	LS45P61B11	\$ 41.00	RM	9.17
LS45M71B11	\$ 47.00	RM	9.40	LS45P32C11	\$ 43.00	RM	9.15	LS45P61C11	\$ 46.00	RM	9.17
LS45M71C11	\$ 53.00	RM	9.40	LS45P32D11	\$ 42.00	RM	9.15	LS45P61D11	\$ 44.00	RM	9.17
LS45M71D11	\$ 51.00	RM	9.40	LS45P32L02	\$ 43.00	RM	9.15	LS45P61L02	\$ 46.00	RM	9.17
LS45M71L02	\$ 53.00	RM	9.40	LS45P32L20	\$ 43.00	RM	9.15	LS45P61L20	\$ 46.00	RM	9.17
LS45M71L20	\$ 53.00	RM	9.40	LS45P33B02	\$ 39.00	RM	9.15	LS45P62B11	\$ 41.00	RM	9.17
LS45M72B02	\$ 52.00	RM	9.41	LS45P33B11	\$ 36.00	RM	9.15	LS45P62B02	\$ 45.00	RM	9.17
LS45M72B11	\$ 47.00	RM	9.41	LS45P33C11	\$ 39.00	RM	9.15	LS45P62C11	\$ 45.00	RM	9.17
LS45M72C11	\$ 52.00	RM	9.41	LS45P33D11	\$ 38.00	RM	9.15	LS45P62D11	\$ 44.00	RM	9.17
LS45M72D11	\$ 50.00	RM	9.41	LS45P33L02	\$ 39.00	RM	9.15	LS45P62L02	\$ 45.00	RM	9.17
LS45M72L02	\$ 52.00	RM	9.41	LS45P33L20	\$ 39.00	RM	9.15	LS45P62L20	\$ 45.00	RM	9.17
LS45M72L20	\$ 52.00	RM	9.41	LS45P41B02	\$ 43.00	RM	9.15	LS45P71B02	\$ 43.00	RM	9.17
LS45M91B02	\$ 45.00	RM	9.41	LS45P41B11	\$ 39.00	RM	9.15	LS45P71B11	\$ 38.00	RM	9.17
LS45M91B11	\$ 41.00	RM	9.41	LS45P41C11	\$ 43.00	RM	9.15	LS45P71C11	\$ 43.00	RM	9.17
LS45M91C11	\$ 45.00	RM	9.41	LS45P41D11	\$ 42.00	RM	9.15	LS45P71D11	\$ 41.00	RM	9.17
LS45M91D11	\$ 43.00	RM	9.41	LS45P41L02	\$ 43.00	RM	9.15	LS45P71L02	\$ 43.00	RM	9.17
LS45M91L02	\$ 45.00	RM	9.41	LS45P41L20	\$ 43.00	RM	9.15	LS45P71L20	\$ 43.00	RM	9.17
LS45M91L20	\$ 45.00	RM	9.41	LS45P42B11	\$ 47.00	RM	9.15	LS45P72B02	\$ 42.00	RM	9.17
LS45M92B11	\$ 43.00	RM	9.41	LS45P42B02	\$ 52.00	RM	9.15	LS45P72B11	\$ 38.00	RM	9.17
LS45M92C11	\$ 47.00	RM	9.41	LS45P42C11	\$ 52.00	RM	9.15	LS45P72C11	\$ 42.00	RM	9.17
LS45M92D11	\$ 46.00	RM	9.41	LS45P42D11	\$ 50.00	RM	9.15	LS45P72D11	\$ 41.00	RM	9.17
LS45M92L02	\$ 47.00	RM	9.41	LS45P42L02	\$ 52.00	RM	9.15	LS45P72L02	\$ 42.00	RM	9.17
LS45M92L20	\$ 47.00	RM	9.41	LS45P42L20	\$ 52.00	RM	9.15	LS45P72L20	\$ 42.00	RM	9.17
LS45M93B02	\$ 47.00	RM	9.41	LS45P43B11	\$ 42.00	RM	9.15	LS45P91B02	\$ 35.00	RM	9.18
LS45M93B11	\$ 42.00	RM	9.41	LS45P43B02	\$ 47.00	RM	9.15	LS45P91B11	\$ 32.00	RM	9.18
LS45M93C11	\$ 47.00	RM	9.41	LS45P43C11	\$ 47.00	RM	9.15	LS45P91C11	\$ 35.00	RM	9.18
LS45M93D11	\$ 45.00	RM	9.41	LS45P43D11	\$ 45.00	RM	9.15	LS45P91D11	\$ 34.00	RM	9.18
LS45M93L02	\$ 47.00	RM	9.41	LS45P43L02	\$ 47.00	RM	9.15	LS45P91L02	\$ 35.00	RM	9.18
LS45M93L20	\$ 47.00	RM	9.41	LS45P43L20	\$ 47.00	RM	9.15	LS45P91L20	\$ 35.00	RM	9.18
LS45P00B02	\$ 25.00	RM	9.22	LS45P44B02	\$ 45.00	RM	9.15	LS45P92B02	\$ 38.00	RM	9.18
LS45P00B11	\$ 23.00	RM	9.22	LS45P44B11	\$ 41.00	RM	9.15	LS45P92B11	\$ 35.00	RM	9.18
LS45P00C11	\$ 25.00	RM	9.22	LS45P44C11	\$ 45.00	RM	9.15	LS45P92C11	\$ 38.00	RM	9.18
LS45P00D11	\$ 24.00	RM	9.22	LS45P44D11	\$ 44.00	RM	9.15	LS45P92D11	\$ 37.00	RM	9.18
LS45P00L02	\$ 25.00	RM	9.22	LS45P44L02	\$ 45.00	RM	9.15	LS45P92L02	\$ 38.00	RM	9.18
LS45P00L20	\$ 25.00	RM	9.22	LS45P44L20	\$ 45.00	RM	9.15	LS45P92L20	\$ 38.00	RM	9.18
LS45P11B02	\$ 33.00	RM	9.14	LS45P51B02	\$ 43.00	RM	9.16	LS45P93B02	\$ 37.00	RM	9.18
LS45P11B11	\$ 30.00	RM	9.14	LS45P51B11	\$ 39.00	RM	9.16	LS45P93B11	\$ 33.00	RM	9.18
LS45P11C11	\$ 33.00	RM	9.14	LS45P51C11	\$ 43.00	RM	9.16	LS45P93C11	\$ 37.00	RM	9.18
LS45P11D11	\$ 32.00	RM	9.14	LS45P51D11	\$ 42.00	RM	9.16	LS45P93D11	\$ 35.00	RM	9.18
LS45P11L02	\$ 33.00	RM	9.14	LS45P51L02	\$ 43.00	RM	9.16	LS45P93L02	\$ 37.00	RM	9.18
LS45P11L20	\$ 33.00	RM	9.14	LS45P51L20	\$ 43.00	RM	9.16	LS45P93L20	\$ 37.00	RM	9.18
LS45P12B02	\$ 35.00	RM	9.14	LS45P52B02	\$ 52.00	RM	9.16	LS65M00B02	\$ 32.00	RM	9.57
LS45P12B11	\$ 32.00	RM	9.14	LS45P52B11	\$ 47.00	RM	9.16	LS65M00B11	\$ 30.00	RM	9.57
LS45P12C11	\$ 35.00	RM	9.14	LS45P52C11	\$ 52.00	RM	9.16	LS65M00C11	\$ 32.00	RM	9.57
LS45P12D11	\$ 34.00	RM	9.14	LS45P52D11	\$ 50.00	RM	9.16	LS65M00D11	\$ 31.00	RM	9.57
LS45P12L02	\$ 35.00	RM	9.14	LS45P52L02	\$ 52.00	RM	9.16	LS65M00L02	\$ 32.00	RM	9.57
LS45P12L20	\$ 35.00	RM	9.14	LS45P52L20	\$ 52.00	RM	9.16	LS65M00L20	\$ 32.00	RM	9.57
LS45P13B02	\$ 40.00	RM	9.14	LS45P53B02	\$ 47.00	RM	9.16	LS65M11B02	\$ 44.00	RM	9.48
LS45P13B11	\$ 37.00	RM	9.14	LS45P53B11	\$ 43.00	RM	9.16	LS65M11B11	\$ 40.00	RM	9.48
LS45P13C11	\$ 40.00	RM	9.14	LS45P53C11	\$ 47.00	RM	9.16	LS65M11C11	\$ 44.00	RM	9.48
LS45P13D11	\$ 39.00	RM	9.14	LS45P53D11	\$ 46.00	RM	9.16	LS65M11D11	\$ 43.00	RM	9.48
LS45P13L02	\$ 40.00	RM	9.14	LS45P53L02	\$ 47.00	RM	9.16	LS65M11L02	\$ 44.00	RM	9.48

LS65M11L20 – LSR1305

Alphanumeric

0

Catalog number	List price	Discount schedule	Page number	Catalog number	List price	Discount schedule	Page number	Catalog number	List price	Discount schedule	Page number
LS65M11L20	\$ 44.00	RM	9.48	LS65M42L20	\$ 65.00	RM	9.50	LS65M72L20	\$ 54.00	RM	9.53
LS65M12B11	\$ 42.00	RM	9.48	LS65M43B02	\$ 60.00	RM	9.51	LS65M91B02	\$ 47.00	RM	9.53
LS65M12B02	\$ 47.00	RM	9.48	LS65M43B11	\$ 54.00	RM	9.51	LS65M91B11	\$ 42.00	RM	9.53
LS65M12C11	\$ 47.00	RM	9.48	LS65M43C11	\$ 60.00	RM	9.51	LS65M91C11	\$ 47.00	RM	9.53
LS65M12D11	\$ 45.00	RM	9.48	LS65M43D11	\$ 58.00	RM	9.51	LS65M91D11	\$ 45.00	RM	9.53
LS65M12L02	\$ 47.00	RM	9.48	LS65M43L02	\$ 60.00	RM	9.51	LS65M91L02	\$ 47.00	RM	9.53
LS65M12L20	\$ 47.00	RM	9.48	LS65M43L20	\$ 60.00	RM	9.51	LS65M91L20	\$ 47.00	RM	9.53
LS65M13B02	\$ 51.00	RM	9.49	LS65M44B02	\$ 58.00	RM	9.51	LS65M92B02	\$ 49.00	RM	9.53
LS65M13B11	\$ 46.00	RM	9.49	LS65M44B11	\$ 53.00	RM	9.51	LS65M92B11	\$ 44.00	RM	9.53
LS65M13C11	\$ 51.00	RM	9.49	LS65M44C11	\$ 58.00	RM	9.51	LS65M92C11	\$ 49.00	RM	9.53
LS65M13D11	\$ 49.00	RM	9.49	LS65M44D11	\$ 56.00	RM	9.51	LS65M92D11	\$ 47.00	RM	9.53
LS65M13L02	\$ 51.00	RM	9.49	LS65M44L02	\$ 58.00	RM	9.51	LS65M92L02	\$ 49.00	RM	9.53
LS65M13L20	\$ 51.00	RM	9.49	LS65M44L20	\$ 58.00	RM	9.51	LS65M92L20	\$ 49.00	RM	9.53
LS65M21B02	\$ 47.00	RM	9.48	LS65M51B02	\$ 59.00	RM	9.51	LS65M93B02	\$ 48.00	RM	9.53
LS65M21B11	\$ 42.00	RM	9.48	LS65M51B11	\$ 53.00	RM	9.51	LS65M93B11	\$ 44.00	RM	9.53
LS65M21C11	\$ 47.00	RM	9.48	LS65M51C11	\$ 59.00	RM	9.51	LS65M93C11	\$ 48.00	RM	9.53
LS65M21D11	\$ 45.00	RM	9.48	LS65M51D11	\$ 57.00	RM	9.51	LS65M93D11	\$ 47.00	RM	9.53
LS65M21L02	\$ 47.00	RM	9.48	LS65M51L02	\$ 59.00	RM	9.51	LS65M93L02	\$ 48.00	RM	9.53
LS65M21L20	\$ 47.00	RM	9.48	LS65M51L20	\$ 59.00	RM	9.51	LS65M93L20	\$ 48.00	RM	9.53
LS65M22B02	\$ 52.00	RM	9.49	LS65M52B02	\$ 67.00	RM	9.51	LSA30P03	\$ 5.00	RM	9.68
LS65M22B11	\$ 47.00	RM	9.49	LS65M52B11	\$ 60.00	RM	9.51	LSA30P04	\$ 5.00	RM	9.68
LS65M22C11	\$ 52.00	RM	9.49	LS65M52C11	\$ 67.00	RM	9.51	LSA30P05	\$ 5.00	RM	9.13
LS65M22D11	\$ 50.00	RM	9.49	LS65M52D11	\$ 65.00	RM	9.51	LSA30P06	\$ 5.00	RM	9.13
LS65M22L02	\$ 52.00	RM	9.49	LS65M52L02	\$ 67.00	RM	9.51	LSA30P07	\$ 9.00	RM	9.69
LS65M22L20	\$ 52.00	RM	9.49	LS65M52L20	\$ 67.00	RM	9.51	LSA30P08	\$ 9.00	RM	9.70
LS65M23B02	\$ 52.00	RM	9.49	LS65M53B02	\$ 62.00	RM	9.51	LSA30P09	\$ 11.00	RM	9.70
LS65M23B11	\$ 47.00	RM	9.49	LS65M53B11	\$ 56.00	RM	9.51	LSA30X41	\$ 3.00	RM	9.13
LS65M23C11	\$ 52.00	RM	9.49	LS65M53C11	\$ 62.00	RM	9.51	LSA30X42	\$ 5.00	RM	9.13
LS65M23D11	\$ 50.00	RM	9.49	LS65M53D11	\$ 60.00	RM	9.51	LSA30X51	\$ 5.00	RM	9.13
LS65M23L02	\$ 52.00	RM	9.49	LS65M53L02	\$ 62.00	RM	9.51	LSA30X52	\$ 6.00	RM	9.13
LS65M23L20	\$ 52.00	RM	9.49	LS65M53L20	\$ 62.00	RM	9.51	LSA30X71	\$ 5.00	RM	9.13
LS65M31B02	\$ 49.00	RM	9.49	LS65M54B02	\$ 60.00	RM	9.52	LSA30X72	\$ 5.00	RM	9.13
LS65M31B11	\$ 44.00	RM	9.49	LS65M54B11	\$ 54.00	RM	9.52	LSA30X73	\$ 5.00	RM	9.13
LS65M31C11	\$ 49.00	RM	9.49	LS65M54C11	\$ 60.00	RM	9.52	LSA30X74	\$ 6.00	RM	9.13
LS65M31D11	\$ 47.00	RM	9.49	LS65M54D11	\$ 58.00	RM	9.52	LSA30X75	\$ 6.00	RM	9.13
LS65M31L02	\$ 49.00	RM	9.49	LS65M54L02	\$ 60.00	RM	9.52	LSA40X41	\$ 6.00	RM	9.23
LS65M31L20	\$ 49.00	RM	9.49	LS65M54L20	\$ 60.00	RM	9.52	LSA40X42	\$ 14.00	RM	9.23
LS65M32B02	\$ 57.00	RM	9.49	LS65M61B02	\$ 57.00	RM	9.52	LSA40X43	\$ 9.00	RM	9.23
LS65M32B11	\$ 51.00	RM	9.49	LS65M61B11	\$ 52.00	RM	9.52	LSA40X44	\$ 8.00	RM	9.23
LS65M32C11	\$ 57.00	RM	9.49	LS65M61C11	\$ 57.00	RM	9.52	LSA40X51	\$ 5.00	RM	9.24
LS65M32D11	\$ 55.00	RM	9.49	LS65M61D11	\$ 55.00	RM	9.52	LSA40X52	\$ 13.00	RM	9.24
LS65M32L02	\$ 57.00	RM	9.49	LS65M61L02	\$ 57.00	RM	9.52	LSA40X53	\$ 9.00	RM	9.24
LS65M32L20	\$ 57.00	RM	9.49	LS65M61L20	\$ 57.00	RM	9.52	LSA40X54	\$ 7.00	RM	9.24
LS65M33B02	\$ 52.00	RM	9.50	LS65M62B02	\$ 57.00	RM	9.52	LSA40X61	\$ 7.00	RM	9.24
LS65M33B11	\$ 47.00	RM	9.50	LS65M62B11	\$ 51.00	RM	9.52	LSA40X62	\$ 7.00	RM	9.24
LS65M33C11	\$ 52.00	RM	9.50	LS65M62C11	\$ 57.00	RM	9.52	LSA40X71	\$ 4.00	RM	9.24
LS65M33D11	\$ 51.00	RM	9.50	LS65M62D11	\$ 55.00	RM	9.52	LSA40X72	\$ 4.00	RM	9.24
LS65M33L02	\$ 52.00	RM	9.50	LS65M62L02	\$ 57.00	RM	9.52	LSA40X73	\$ 5.00	RM	9.24
LS65M33L20	\$ 52.00	RM	9.50	LS65M62L20	\$ 57.00	RM	9.52	LSC30XB02	\$ 16.00	RM	9.13
LS65M41B02	\$ 57.00	RM	9.50	LS65M71B02	\$ 54.00	RM	9.53	LSC30XB11	\$ 14.00	RM	9.13
LS65M41B11	\$ 51.00	RM	9.50	LS65M71B11	\$ 49.00	RM	9.53	LSC30XC11	\$ 16.00	RM	9.13
LS65M41C11	\$ 57.00	RM	9.50	LS65M71C11	\$ 54.00	RM	9.53	LSC30XD11	\$ 14.00	RM	9.13
LS65M41D11	\$ 55.00	RM	9.50	LS65M71D11	\$ 53.00	RM	9.53	LSC30XL02	\$ 16.00	RM	9.13
LS65M41L02	\$ 57.00	RM	9.50	LS65M71L02	\$ 54.00	RM	9.53	LSC30XL20	\$ 16.00	RM	9.13
LS65M41L20	\$ 57.00	RM	9.50	LS65M71L20	\$ 54.00	RM	9.53	LSC40XB02	\$ 17.00	RM	9.24
LS65M42B02	\$ 65.00	RM	9.50	LS65M72B02	\$ 54.00	RM	9.53	LSC40XB11	\$ 15.00	RM	9.24
LS65M42B11	\$ 58.00	RM	9.50	LS65M72B11	\$ 49.00	RM	9.53	LSC40XC11	\$ 17.00	RM	9.24
LS65M42C11	\$ 65.00	RM	9.50	LS65M72C11	\$ 54.00	RM	9.53	LSC40XD11	\$ 15.00	RM	9.24
LS65M42D11	\$ 63.00	RM	9.50	LS65M72D11	\$ 52.00	RM	9.53	LSC40XL02	\$ 17.00	RM	9.24
LS65M42L02	\$ 65.00	RM	9.50	LS65M72L02	\$ 54.00	RM	9.53	LSC40XL20	\$ 17.00	RM	9.24
								LSR1305	\$ 5.00	RM	9.13

LSTE11 – MS496-100E

Catalog number	List price	Discount schedule	Page number	Catalog number	List price	Discount schedule	Page number	Catalog number	List price	Discount schedule	Page number
LSTE11	\$ 14.00	RM	9.45	LT300-AC	\$ 10.00	ABA	1.29	MS325-HKF11	\$ 33.00	MA	5.11
LSTE12	\$ 17.00	RM	9.45	LT300-AL	\$ 10.00	ABA	1.29	MS325-HKF20	\$ 33.00	MA	5.11
LSTE13	\$ 20.00	RM	9.45	LT300-AY	\$ 10.00	ABA	1.29	MS325-SA1	\$ 15.00	MA	5.11
LSTE21	\$ 17.00	RM	9.45	LT320E	\$ 41.00	ABA	2.22	MS325-SA3	\$ 37.50	MA	5.11
LSTE22	\$ 21.00	RM	9.45	LT460-AC	\$ 20.00	ABA	1.29	MS325-SK01	\$ 33.00	MA	5.11
LSTE23	\$ 21.00	RM	9.45	LT460-AL	\$ 20.00	ABA	1.29	MS325-SK10	\$ 33.00	MA	5.11
LSTE31	\$ 19.00	RM	9.45	LT500E	\$ 52.00	ABA	2.22	MS325-SM1	\$ 24.00	MA	5.12
LSTE32	\$ 26.00	RM	9.45	LT6-B	\$ 15.00	AA	4.12	MS325-ST110	\$ 82.50	MA	5.11
LSTE33	\$ 21.00	RM	9.45	LT750-AC	\$ 20.00	ABA	1.29	MS325-ST24	\$ 82.50	MA	5.11
LSTE40	\$ 20.00	RM	9.46	LT750-AL	\$ 20.00	ABA	1.29	MS325-UA110	\$ 82.50	MA	5.11
LSTE41	\$ 26.00	RM	9.46	LT800E	\$ 56.00	ABA	2.22	MS325-UA230	\$ 82.50	MA	5.11
LSTE42	\$ 34.00	RM	9.46	LW-110	\$ 15.00	ABA	1.29	MS325-UA24	\$ 82.50	MA	5.11
LSTE43	\$ 29.00	RM	9.46	LW110	\$ 95.00	ABA	1.29	MS325-UA400	\$ 82.50	MA	5.11
LSTE44	\$ 28.00	RM	9.46	LW185	\$ 120.00	ABA	1.29	MS325-UA415	\$ 82.50	MA	5.11
LSTE50	\$ 22.00	RM	9.47	LW300	\$ 130.00	ABA	1.29	MS325-UA48	\$ 82.50	MA	5.11
LSTE51	\$ 27.00	RM	9.46	LW460	\$ 295.00	ABA	1.29	MS325-UA480	\$ 82.50	MA	5.11
LSTE52	\$ 35.00	RM	9.46	LW750	\$ 355.00	ABA	1.29	MS325-UA60	\$ 82.50	MA	5.11
LSTE53	\$ 31.00	RM	9.46	LX185	\$ 90.00	ABA	1.29	MS325-VB7	\$ 12.00	MA	5.12
LSTE54	\$ 29.00	RM	9.46	LX300	\$ 140.00	ABA	1.29	MS450-16	\$ 450.00	MA	5.15
LSTE61	\$ 29.00	RM	9.46	LX460	\$ 195.00	ABA	1.29	MS450-16E	\$ 525.00	MA	5.16
LSTE62	\$ 29.00	RM	9.46	LX750	\$ 225.00	ABA	1.29	MS450-20	\$ 450.00	MA	5.15
LSTE71	\$ 26.00	RM	9.46	LY110	\$ 40.00	ABA	1.3	MS450-20E	\$ 525.00	MA	5.16
LSTE72	\$ 26.00	RM	9.46	LY185	\$ 40.00	ABA	1.3	MS450-25	\$ 450.00	MA	5.15
LSTE73	\$ 27.00	RM	9.46	LY460	\$ 60.00	ABA	1.3	MS450-25E	\$ 525.00	MA	5.16
LSTE91	\$ 17.00	RM	9.46	LY750	\$ 60.00	ABA	1.3	MS450-32	\$ 450.00	MA	5.15
LSTE92	\$ 19.00	RM	9.46	LYA300	\$ 60.00	ABA	1.3	MS450-32E	\$ 525.00	MA	5.16
LSTE93	\$ 18.00	RM	9.46	MB-3PD	\$ 35.00	CB8	14.19	MS450-40	\$ 510.00	MA	5.15
LSTH11	\$ 9.00	RM	9.22	MB-CL	\$ 35.00	CB8	14.19	MS450-40E	\$ 585.00	MA	5.16
LSTH12	\$ 11.00	RM	9.22	MB5	\$ 25.00	RA	10.122	MS450-45	\$ 510.00	MA	5.15
LSTH13	\$ 16.00	RM	9.22	MS116-0.16	\$ 129.00	MA	5.3	MS450-45E	\$ 585.00	MA	5.16
LSTH14	\$ 12.00	RM	9.22	MS116-0.40	\$ 129.00	MA	5.3	MS450-50	\$ 510.00	MA	5.15
LSTH19	\$ 19.00	RM	9.22	MS116-0.63	\$ 129.00	MA	5.3	MS450-50E	\$ 585.00	MA	5.16
LSTH32	\$ 20.00	RM	9.22	MS116-1.0	\$ 148.50	MA	5.3	MS451-16	\$ 450.00	MA	5.15
LSTH33	\$ 17.00	RM	9.22	MS116-1.6	\$ 148.50	MA	5.3	MS451-16E	\$ 525.00	MA	5.16
LSTH35	\$ 18.00	RM	9.22	MS116-10	\$ 172.50	MA	5.3	MS451-20	\$ 450.00	MA	5.15
LSTH36	\$ 23.00	RM	9.22	MS116-12	\$ 172.50	MA	5.3	MS451-20E	\$ 525.00	MA	5.16
LSTH37	\$ 20.00	RM	9.22	MS116-16	\$ 172.50	MA	5.3	MS451-25	\$ 450.00	MA	5.15
LSTH40	\$ 14.00	RM	9.23	MS116-2.5	\$ 148.50	MA	5.3	MS451-25E	\$ 525.00	MA	5.16
LSTH41	\$ 20.00	RM	9.23	MS116-4.0	\$ 148.50	MA	5.3	MS451-32	\$ 450.00	MA	5.15
LSTH42	\$ 28.00	RM	9.23	MS116-6.3	\$ 148.50	MA	5.3	MS451-32E	\$ 525.00	MA	5.16
LSTH43	\$ 23.00	RM	9.23	MS116.0.25	\$ 129.00	MA	5.3	MS451-40	\$ 510.00	MA	5.15
LSTH44	\$ 22.00	RM	9.23	MS325-0.16	\$ 144.00	MA	5.13	MS451-40E	\$ 585.00	MA	5.16
LSTH50	\$ 15.00	RM	9.24	MS325-0.25	\$ 144.00	MA	5.13	MS451-45	\$ 510.00	MA	5.15
LSTH51	\$ 20.00	RM	9.23	MS325-0.40	\$ 144.00	MA	5.13	MS451-45E	\$ 585.00	MA	5.16
LSTH52	\$ 28.00	RM	9.23	MS325-0.63	\$ 144.00	MA	5.13	MS451-50	\$ 510.00	MA	5.15
LSTH53	\$ 24.00	RM	9.23	MS325-1.0	\$ 165.00	MA	5.13	MS451-50E	\$ 585.00	MA	5.16
LSTH54	\$ 22.00	RM	9.23	MS325-1.6	\$ 165.00	MA	5.13	MS495-100	\$ 690.00	MA	5.15
LSTH61	\$ 22.00	RM	9.23	MS325-12.5	\$ 192.00	MA	5.13	MS495-100E	\$ 810.00	MA	5.16
LSTH62	\$ 22.00	RM	9.23	MS325-16	\$ 192.00	MA	5.13	MS495-40	\$ 562.50	MA	5.15
LSTH71	\$ 19.00	RM	9.23	MS325-2.5	\$ 165.00	MA	5.13	MS495-40E	\$ 622.50	MA	5.16
LSTH72	\$ 19.00	RM	9.23	MS325-20	\$ 211.50	MA	5.13	MS495-50	\$ 562.50	MA	5.15
LSTH73	\$ 20.00	RM	9.23	MS325-25	\$ 223.50	MA	5.13	MS495-50E	\$ 622.50	MA	5.16
LSTH91	\$ 13.00	RM	9.23	MS325-4.0	\$ 165.00	MA	5.13	MS495-63	\$ 562.50	MA	5.15
LSTH92	\$ 16.00	RM	9.23	MS325-6.3	\$ 165.00	MA	5.13	MS495-63E	\$ 622.50	MA	5.16
LSTH93	\$ 14.00	RM	9.23	MS325-9.0	\$ 192.00	MA	5.13	MS495-75	\$ 600.00	MA	5.15
LT185-AC	\$ 10.00	ABA	1.29	MS325-AS	\$ 15.00	MA	5.11	MS495-75E	\$ 720.00	MA	5.16
LT185-AL	\$ 10.00	ABA	1.29	MS325-BB1	\$ 25.50	MA	5.12	MS495-90	\$ 615.00	MA	5.15
LT185-AY	\$ 10.00	ABA	1.29	MS325-HK02	\$ 33.00	MA	5.11	MS495-90E	\$ 735.00	MA	5.16
LT200A185	\$ 50.00	ABA	2.7	MS325-HK11	\$ 33.00	MA	5.11	MS496-100	\$ 690.00	MA	5.15
LT200E	\$ 41.00	ABA	2.22	MS325-HK20	\$ 33.00	MA	5.11	MS496-100E	\$ 810.00	MA	5.16

MS496-40 – NF16003-4P8A

Alphanumeric

0

Catalog number	List price	Discount schedule	Page number	Catalog number	List price	Discount schedule	Page number	Catalog number	List price	Discount schedule	Page number
MS496-40	\$ 562.50	MA	5.15	NF1003-3MB6B	\$ 1,930.00	H1E	17.138	NF1200P-3MB4A	\$ 38,360.00	H3E	17.138
MS496-40E	\$ 622.50	MA	5.16	NF1003-3PB6B	\$ 880.00	H1E	17.130	NF1200P-3PB4A	\$ 19,000.00	H3E	17.131
MS496-50	\$ 562.50	MA	5.15	NF1003-3TB8B	\$ 1,930.00	H1E	17.136	NF1200P-3TB4A	\$ 38,660.00	H3E	17.136
MS496-50E	\$ 622.50	MA	5.16	NF1003-4PB6B	\$ 1,088.00	H1E	17.134	NF1200P-4PB4A	\$ 23,750.00	H3E	17.134
MS496-63	\$ 562.50	MA	5.15	NF1003-6PB6B	\$ 1,870.00	H1E	17.135	NF1200P-6PB8A	\$ 38,360.00	H3E	17.135
MS496-63E	\$ 622.50	MA	5.16	NF1004-3BB8B	\$ 3,000.00	H1E	17.137	NF1200X-2PB4A	\$ 20,250.00	H3E	17.133
MS496-75	\$ 600.00	MA	5.15	NF1004-3MB6B	\$ 2,270.00	H1E	17.138	NF1200X-3B6A	\$ 68,800.00	H3E	17.137
MS496-75E	\$ 720.00	MA	5.16	NF1004-3PB6B	\$ 1,190.00	H1E	17.130	NF1200X-3MB4A	\$ 45,420.00	H3E	17.138
MS496-90	\$ 615.00	MA	5.15	NF1004-3TB8B	\$ 2,500.00	H1E	17.136	NF1200X-3PB4A	\$ 22,500.00	H3E	17.130
MS496-90E	\$ 735.00	MA	5.16	NF1004-4PB6B	\$ 1,300.00	H1E	17.134	NF1200X-3TB4A	\$ 45,660.00	H3E	17.136
MS497-100	\$ 690.00	MA	5.15	NF1004-6PB6B	\$ 2,210.00	H1E	17.135	NF1200X-4PB4A	\$ 28,125.00	H3E	17.134
MS497-100E	\$ 810.00	MA	5.16	NF1007-3P	\$ 2,900.00	H1E	17.131	NF1200X-6PB8A	\$ 45,360.00	H3E	17.135
MS497-16	\$ 450.00	MA	5.15	NF1007-3T	\$ 5,800.00	H1E	17.136	NF1251-2PB6A	\$ 825.00	H2E	17.133
MS497-16E	\$ 570.00	MA	5.16	NF1007-4P	\$ 3,150.00	H1E	17.134	NF1251-3MB6A	\$ 2,260.00	H2E	17.138
MS497-20	\$ 450.00	MA	5.15	NF1007-6P	\$ 3,150.00	H1E	17.135	NF1251-3PB6A	\$ 1,100.00	H2E	17.130
MS497-20E	\$ 570.00	MA	5.16	NF100E-3PB6A	\$ 660.00	H1E	17.131	NF1251-3TB8A	\$ 2,380.00	H2E	17.136
MS497-25	\$ 450.00	MA	5.15	NF100E-4PB4B	\$ 750.00	H1E	17.134	NF1251-4PB6A	\$ 1,375.00	H2E	17.134
MS497-25E	\$ 570.00	MA	5.16	NF100E-6PB6B	\$ 1,330.00	H1E	17.135	NF1251-6PB2A	\$ 2,200.00	H2E	17.135
MS497-32	\$ 450.00	MA	5.15	NF100P-3BB8B	\$ 2,600.00	H1E	17.137	NF1252-2PB6A	\$ 1,050.00	H2E	17.133
MS497-32E	\$ 570.00	MA	5.16	NF100P-3MB6B	\$ 2,000.00	H1E	17.138	NF1252-3MB6A	\$ 2,860.00	H2E	17.138
MS497-40	\$ 562.50	MA	5.15	NF100P-3PB6B	\$ 975.00	H1E	17.131	NF1252-3PB6A	\$ 1,400.00	H2E	17.131
MS497-40E	\$ 622.50	MA	5.16	NF100P-3TB8B	\$ 2,100.00	H1E	17.136	NF1252-3TB8A	\$ 2,980.00	H2E	17.136
MS497-50	\$ 562.50	MA	5.15	NF100P-4PB6B	\$ 1,200.00	H1E	17.134	NF1252-4PB6A	\$ 1,750.00	H2E	17.134
MS497-50E	\$ 622.50	MA	5.16	NF100P-6PB6B	\$ 2,000.00	H1E	17.135	NF1252-6PB4A	\$ 2,800.00	H2E	17.135
MS497-63	\$ 562.50	MA	5.15	NF100X-3BB8B	\$ 5,000.00	H1E	17.137	NF1253-2PB6A	\$ 1,050.00	H2E	17.133
MS497-63E	\$ 622.50	MA	5.16	NF100X-3MB6B	\$ 2,800.00	H1E	17.138	NF1253-3MB6A	\$ 2,860.00	H2E	17.138
MS497-75	\$ 600.00	MA	5.15	NF100X-3PB6B	\$ 1,300.00	H1E	17.130	NF1253-3PB6A	\$ 1,400.00	H2E	17.130
MS497-75E	\$ 720.00	MA	5.16	NF100X-3TB8B	\$ 4,000.00	H1E	17.136	NF1253-3TB8A	\$ 2,980.00	H2E	17.136
MS497-90	\$ 615.00	MA	5.15	NF100X-4PB6B	\$ 1,625.00	H1E	17.134	NF1253-4PB6A	\$ 1,675.00	H2E	17.134
MS497-90E	\$ 735.00	MA	5.16	NF100X-6PB6B	\$ 2,760.00	H1E	17.135	NF1253-6PB2A	\$ 2,800.00	H2E	17.135
MSMN	\$ 15.00	MA	5.5	NF12001-2PB4A	\$ 9,000.00	H3E	17.133	NF1254-2PB8A	\$ 2,100.00	H2E	17.133
N22E-84	\$ 60.00	KCN	7.5	NF12001-3B6A	\$ 30,660.00	H3E	17.137	NF1254-3MB8A	\$ 5,660.00	H2E	17.138
N3150X-2P8A	\$ 44,100.00	H3E	17.133	NF12001-3MB4A	\$ 20,420.00	H3E	17.138	NF1254-3PB8A	\$ 2,800.00	H2E	17.130
N31E-84	\$ 60.00	KCN	7.5	NF12001-3PB4A	\$ 10,000.00	H3E	17.130	NF1254-3TB8A	\$ 3,500.00	H2E	17.136
N40E-84	\$ 60.00	KCN	7.5	NF12001-3TB4A	\$ 20,660.00	H3E	17.136	NF1254-4PB6A	\$ 4,500.00	H2E	17.134
N44E-84	\$ 120.00	KCN	7.5	NF12001-4PB4A	\$ 12,500.00	H3E	17.134	NF1254-6PB4A	\$ 5,600.00	H2E	17.135
N53E-84	\$ 120.00	KCN	7.5	NF12001-6PB8A	\$ 20,360.00	H3E	17.135	NF1257-3P	\$ 4,000.00	H2E	17.131
N62E-84	\$ 120.00	KCN	7.5	NF12002-2PB4A	\$ 9,360.00	H3E	17.133	NF1257-4P	\$ 5,500.00	H2E	17.134
N71E-84	\$ 120.00	KCN	7.5	NF12002-3B6A	\$ 31,860.00	H3E	17.137	NF125E-3PB6A	\$ 1,100.00	H2E	17.131
N80E-84	\$ 120.00	KCN	7.5	NF12002-3MB4A	\$ 24,020.00	H3E	17.138	NF125P-2PB8A	\$ 2,250.00	H2E	17.133
NE12E-86	\$ 72.00	KCN	7.5	NF12002-3PB4A	\$ 10,400.00	H3E	17.131	NF125P-3MB8A	\$ 6,000.00	H2E	17.138
NE21E-86	\$ 72.00	KCN	7.5	NF12002-3TB4A	\$ 21,460.00	H3E	17.136	NF125P-3PB8A	\$ 3,000.00	H2E	17.131
NE30E-86	\$ 72.00	KCN	7.5	NF12002-4PB4A	\$ 13,000.00	H3E	17.134	NF125P-3TB8A	\$ 3,200.00	H2E	17.136
NE43E-86	\$ 144.00	KCN	7.5	NF12002-6PB8A	\$ 21,800.00	H3E	17.135	NF125P-4PB8A	\$ 3,750.00	H2E	17.134
NE52E-86	\$ 144.00	KCN	7.5	NF12003-2PB4A	\$ 10,620.00	H3E	17.133	NF125P-6PB4A	\$ 6,000.00	H2E	17.135
NE61E-86	\$ 144.00	KCN	7.5	NF12003-3B6A	\$ 36,060.00	H3E	17.137	NF125X-2PB8A	\$ 2,625.00	H2E	17.133
NE70E-86	\$ 144.00	KCN	7.5	NF12003-3MB4A	\$ 24,020.00	H3E	17.138	NF125X-3MB8A	\$ 7,060.00	H2E	17.138
NF1001-3BB8B	\$ 2,170.00	H1E	17.137	NF12003-3PB4A	\$ 11,800.00	H3E	17.130	NF125X-3PB8A	\$ 3,500.00	H2E	17.130
NF1001-3MB6B	\$ 1,390.00	H1E	17.138	NF12003-3TB4A	\$ 24,260.00	H3E	17.136	NF125X-3TB8A	\$ 5,000.00	H2E	17.136
NF1001-3PB6B	\$ 610.00	H1E	17.130	NF12003-4PB4A	\$ 14,750.00	H3E	17.134	NF125X-4PB8A	\$ 4,375.00	H2E	17.134
NF1001-3TB8B	\$ 1,510.00	H1E	17.136	NF12003-6PB4A	\$ 23,960.00	H3E	17.135	NF125X-6PB4A	\$ 7,000.00	H2E	17.135
NF1001-4PB6B	\$ 750.00	H1E	17.134	NF12004-2PB4A	\$ 16,200.00	H3E	17.133	NF16001-2PB8A	\$ 17,100.00	H3E	17.133
NF1001-6PB6B	\$ 1,330.00	H1E	17.135	NF12004-3B6A	\$ 55,040.00	H3E	17.137	NF16001-3PB8A	\$ 19,000.00	H3E	17.130
NF1002-3BB8B	\$ 2,500.00	H1E	17.137	NF12004-3MB4A	\$ 36,350.00	H3E	17.138	NF16001-4PB8A	\$ 23,750.00	H3E	17.134
NF1002-3MB6B	\$ 1,930.00	H1E	17.138	NF12004-3PB4A	\$ 18,000.00	H3E	17.130	NF16002-2PB8A	\$ 17,460.00	H3E	17.133
NF1002-3PB6B	\$ 880.00	H1E	17.131	NF12004-3TB4A	\$ 36,530.00	H3E	17.136	NF16002-3PB8A	\$ 19,400.00	H3E	17.131
NF1002-3TB8B	\$ 1,930.00	H1E	17.136	NF12004-4PB4A	\$ 22,500.00	H3E	17.134	NF16002-4PB8A	\$ 24,250.00	H3E	17.134
NF1002-4PB6B	\$ 1,025.00	H1E	17.134	NF12004-6PB8A	\$ 36,290.00	H3E	17.135	NF16003-2PB8A	\$ 18,720.00	H3E	17.133
NF1002-6PB6B	\$ 1,770.00	H1E	17.135	NF1200P-2PB4A	\$ 17,100.00	H3E	17.133	NF16003-3PB8A	\$ 20,800.00	H3E	17.130
NF1003-3BB8B	\$ 2,500.00	H1E	17.137	NF1200P-3B6A	\$ 57,660.00	H3E	17.137	NF16003-4PB8A	\$ 26,000.00	H3E	17.134

NF16004-2P8A – NF303-3BB8B

Catalog number	List price	Discount schedule	Page number	Catalog number	List price	Discount schedule	Page number	Catalog number	List price	Discount schedule	Page number
NF16004-2P8A	\$ 27,360.00	H3E	17.133	NF20001-4P8A	\$ 28,750.00	H3E	17.134	NF251-3PB6A	\$ 240.00	H1E	17.130
NF16004-3P8A	\$ 30,400.00	H3E	17.130	NF20002-2P8A	\$ 21,060.00	H3E	17.133	NF251-3PBJA	\$ 190.00	H1E	17.130
NF16004-4P8A	\$ 38,800.00	H3E	17.134	NF20002-3P8A	\$ 23,400.00	H3E	17.131	NF251-3TB8A	\$ 770.00	H1E	17.136
NF1600P-2P8A	\$ 28,000.00	H3E	17.133	NF20002-4P8A	\$ 29,240.00	H3E	17.134	NF251-4PB6A	\$ 300.00	H1E	17.134
NF1600P-3P8A	\$ 31,000.00	H3E	17.131	NF20003-2P8A	\$ 22,500.00	H3E	17.133	NF251-6PB6A	\$ 590.00	H1E	17.135
NF1600P-4P8A	\$ 38,500.00	H3E	17.134	NF20003-3P8A	\$ 25,000.00	H3E	17.130	NF252-3BB8A	\$ 1,282.00	H1E	17.137
NF1600X-2P8A	\$ 34,200.00	H3E	17.133	NF20003-4P8A	\$ 31,250.00	H3E	17.134	NF252-3MB6A	\$ 798.00	H1E	17.138
NF1600X-3P8A	\$ 38,000.00	H3E	17.130	NF20004-2P8A	\$ 31,680.00	H3E	17.133	NF252-3PB6A	\$ 314.00	H1E	17.131
NF1600X-4P8A	\$ 47,500.00	H3E	17.134	NF20004-3P8A	\$ 35,200.00	H3E	17.130	NF252-3PBJA	\$ 264.00	H1E	17.131
NF161-3BB8A	\$ 1,045.00	H1E	17.137	NF20004-4P8A	\$ 44,000.00	H3E	17.134	NF252-3TB8A	\$ 918.00	H1E	17.136
NF161-3MB6A	\$ 640.00	H1E	17.138	NF2000P-2P8A	\$ 33,300.00	H3E	17.133	NF252-4PB6A	\$ 374.00	H1E	17.134
NF161-3PB6A	\$ 235.00	H1E	17.130	NF2000P-3P8A	\$ 37,000.00	H3E	17.131	NF252-6PB6A	\$ 738.00	H1E	17.135
NF161-3PBJA	\$ 185.00	H1E	17.130	NF2000P-4P8A	\$ 46,250.00	H3E	17.134	NF253-3BB8A	\$ 1,282.00	H1E	17.137
NF161-3TB8A	\$ 760.00	H1E	17.136	NF2000X-2P8A	\$ 39,600.00	H3E	17.133	NF253-3MB6A	\$ 798.00	H1E	17.138
NF161-4PB6A	\$ 295.00	H1E	17.134	NF2000X-3P8A	\$ 44,000.00	H3E	17.130	NF253-3PB6A	\$ 314.00	H1E	17.130
NF161-6PB6A	\$ 580.00	H1E	17.135	NF2000X-4P8A	\$ 55,000.00	H3E	17.134	NF253-3PBJA	\$ 264.00	H1E	17.130
NF162-3BB8A	\$ 1,267.00	H1E	17.137	NF2001-2PB8A	\$ 1,170.00	H2E	17.133	NF253-3TB8A	\$ 918.00	H1E	17.136
NF162-3MB6A	\$ 788.00	H1E	17.138	NF2001-3BB4A	\$ 4,520.00	H2E	17.137	NF253-4PB6A	\$ 374.00	H1E	17.134
NF162-3PB6A	\$ 309.00	H1E	17.131	NF2001-3MB8A	\$ 3,010.00	H2E	17.138	NF253-6PB6A	\$ 738.00	H1E	17.135
NF162-3PBJA	\$ 259.00	H1E	17.131	NF2001-3PB8A	\$ 1,300.00	H2E	17.130	NF254-3BB8A	\$ 1,540.00	H1E	17.137
NF162-3TB8A	\$ 908.00	H1E	17.136	NF2001-3TB4A	\$ 3,150.00	H2E	17.136	NF254-3MB6A	\$ 1,160.00	H1E	17.138
NF162-4PB6A	\$ 369.00	H1E	17.134	NF2001-4PB8A	\$ 1,625.00	H2E	17.134	NF254-3PB6A	\$ 480.00	H1E	17.130
NF162-6PB6A	\$ 728.00	H1E	17.135	NF2001-6PB4A	\$ 2,950.00	H2E	17.135	NF254-3TB8A	\$ 1,230.00	H1E	17.136
NF163-3BB8A	\$ 1,267.00	H1E	17.137	NF2002-2PB8A	\$ 1,440.00	H2E	17.133	NF254-4PB6A	\$ 535.00	H1E	17.134
NF163-3MB6A	\$ 788.00	H1E	17.138	NF2002-3BB4A	\$ 5,420.00	H2E	17.137	NF254-6PB6A	\$ 1,090.00	H1E	17.135
NF163-3PB6A	\$ 309.00	H1E	17.130	NF2002-3MB8A	\$ 3,710.00	H2E	17.138	NF257-3P	\$ 1,375.00	H1E	17.131
NF163-3PBJA	\$ 259.00	H1E	17.130	NF2002-3PB8A	\$ 1,600.00	H2E	17.131	NF257-3T	\$ 4,290.00	H1E	17.136
NF163-3TB8A	\$ 908.00	H1E	17.136	NF2002-3TB4A	\$ 3,750.00	H2E	17.136	NF257-4P	\$ 1,475.00	H1E	17.134
NF163-4PB6A	\$ 369.00	H1E	17.134	NF2002-4PB8A	\$ 2,000.00	H2E	17.134	NF257-6P	\$ 4,290.00	H1E	17.135
NF163-6PB6A	\$ 728.00	H1E	17.135	NF2002-6PB4A	\$ 3,550.00	H2E	17.135	NF25E-3PB4B	\$ 240.00	H1E	17.131
NF164-3BB8A	\$ 1,480.00	H1E	17.137	NF2003-2PB8A	\$ 1,485.00	H2E	17.133	NF25E-3PBJA	\$ 190.00	H1E	17.131
NF164-3MB6A	\$ 1,120.00	H1E	17.138	NF2003-3BB4A	\$ 5,570.00	H2E	17.137	NF25E-3PBJB	\$ 215.00	H1E	17.131
NF164-3PB6A	\$ 475.00	H1E	17.130	NF2003-3MB8A	\$ 3,710.00	H2E	17.138	NF25E-4PBJB	\$ 250.00	H1E	17.134
NF164-3TB8A	\$ 1,200.00	H1E	17.136	NF2003-3PB8A	\$ 1,650.00	H2E	17.130	NF25E-6PBJB	\$ 420.00	H1E	17.135
NF164-4PB6A	\$ 530.00	H1E	17.134	NF2003-3TB4A	\$ 3,850.00	H2E	17.136	NF25P-3BB8A	\$ 1,325.00	H1E	17.137
NF164-6PB6A	\$ 1,080.00	H1E	17.135	NF2003-4PB8A	\$ 2,063.00	H2E	17.134	NF25P-3MB6A	\$ 870.00	H1E	17.138
NF167-3P	\$ 1,350.00	H1E	17.131	NF2003-6PB4A	\$ 3,650.00	H2E	17.135	NF25P-3PB6A	\$ 350.00	H1E	17.131
NF167-3T	\$ 4,280.00	H1E	17.136	NF2004-2PB8A	\$ 3,170.00	H2E	17.133	NF25P-3PBJA	\$ 300.00	H1E	17.131
NF167-4P	\$ 1,450.00	H1E	17.134	NF2004-3BB4A	\$ 11,050.00	H2E	17.137	NF25P-3TB8A	\$ 1,040.00	H1E	17.136
NF167-6P	\$ 4,280.00	H1E	17.135	NF2004-3MB8A	\$ 7,380.00	H2E	17.138	NF25P-4PB6A	\$ 410.00	H1E	17.134
NF16E-3PB4B	\$ 235.00	H1E	17.131	NF2004-3PB8A	\$ 3,520.00	H2E	17.130	NF25P-6PB6A	\$ 810.00	H1E	17.135
NF16E-3PBJA	\$ 185.00	H1E	17.131	NF2004-3TB4A	\$ 7,480.00	H2E	17.136	NF25X-3BB8A	\$ 3,820.00	H1E	17.137
NF16E-3PBJB	\$ 210.00	H1E	17.131	NF2004-4PB8A	\$ 4,400.00	H2E	17.134	NF25X-3MB6A	\$ 1,420.00	H1E	17.138
NF16E-4PBJB	\$ 245.00	H1E	17.134	NF2004-6PB4A	\$ 7,320.00	H2E	17.135	NF25X-3PB6A	\$ 590.00	H1E	17.130
NF16E-6PBJB	\$ 410.00	H1E	17.135	NF200P-2PB8A	\$ 3,600.00	H2E	17.133	NF25X-3TB8A	\$ 1,880.00	H1E	17.136
NF16P-3BB8A	\$ 1,300.00	H1E	17.137	NF200P-3BB4A	\$ 12,620.00	H2E	17.137	NF25X-4PB6A	\$ 670.00	H1E	17.134
NF16P-3MB6A	\$ 860.00	H1E	17.138	NF200P-3MB8A	\$ 8,350.00	H2E	17.138	NF25X-6PB6A	\$ 1,360.00	H1E	17.135
NF16P-3PB6A	\$ 345.00	H1E	17.131	NF200P-3PB8A	\$ 4,000.00	H2E	17.131	NF301-3BB8B	\$ 1,970.00	H1E	17.137
NF16P-3PBJA	\$ 295.00	H1E	17.131	NF200P-3TB4A	\$ 8,550.00	H2E	17.136	NF301-3MB6B	\$ 1,290.00	H1E	17.138
NF16P-3TB8A	\$ 1,000.00	H1E	17.136	NF200P-4PB8A	\$ 5,000.00	H2E	17.134	NF301-3PB6B	\$ 510.00	H1E	17.130
NF16P-4PB6A	\$ 405.00	H1E	17.134	NF200P-6PB4A	\$ 8,350.00	H2E	17.135	NF301-3TB8B	\$ 1,410.00	H1E	17.136
NF16P-6PB6A	\$ 800.00	H1E	17.135	NF200X-2PB8A	\$ 3,960.00	H2E	17.133	NF301-4PB6B	\$ 650.00	H1E	17.134
NF16X-3BB8A	\$ 3,740.00	H1E	17.137	NF200X-3BB4A	\$ 13,820.00	H2E	17.137	NF301-6PB6B	\$ 1,230.00	H1E	17.135
NF16X-3MB6A	\$ 1,410.00	H1E	17.138	NF200X-3MB8A	\$ 9,210.00	H2E	17.138	NF302-3BB8B	\$ 2,300.00	H1E	17.137
NF16X-3PB6A	\$ 585.00	H1E	17.130	NF200X-3PB8A	\$ 4,400.00	H2E	17.130	NF302-3MB6B	\$ 1,830.00	H1E	17.138
NF16X-3TB8A	\$ 1,850.00	H1E	17.136	NF200X-3TB4A	\$ 9,350.00	H2E	17.136	NF302-3PB6B	\$ 780.00	H2E	17.131
NF16X-4PB6A	\$ 665.00	H1E	17.134	NF200X-4PB8A	\$ 5,500.00	H2E	17.134	NF302-3TB8B	\$ 1,730.00	H1E	17.136
NF16X-6PB6A	\$ 1,350.00	H1E	17.135	NF200X-6PB4A	\$ 9,150.00	H2E	17.135	NF302-4PB6B	\$ 925.00	H1E	17.134
NF20001-2P8A	\$ 20,700.00	H3E	17.133	NF251-3BB8A	\$ 1,060.00	H1E	17.137	NF302-6PB6B	\$ 1,670.00	H1E	17.135
NF20001-3P8A	\$ 23,000.00	H3E	17.130	NF251-3MB6A	\$ 650.00	H1E	17.138	NF303-3BB8B	\$ 2,300.00	H1E	17.137

NF303-3MB6B – NF45P-6PB6B

Alphanumeric

0

Catalog number	List price	Discount schedule	Page number	Catalog number	List price	Discount schedule	Page number	Catalog number	List price	Discount schedule	Page number
NF303-3MB6B	\$ 1,830.00	H1E	17.138	NF322-6PB6A	\$ 758.00	H1E	17.135	NF4004-3PB4A	\$ 6,400.00	H2E	17.130
NF303-3PB6B	\$ 780.00	H1E	17.130	NF323-3BB8A	\$ 1,297.00	H1E	17.137	NF4004-3TB4A	\$ 13,250.00	H2E	17.136
NF303-3TB8B	\$ 1,830.00	H1E	17.136	NF323-3MB6A	\$ 818.00	H1E	17.138	NF4004-4PB4A	\$ 8,000.00	H2E	17.134
NF303-4PB6B	\$ 988.00	H1E	17.134	NF323-3PB6A	\$ 329.00	H1E	17.130	NF4004-6P8A	\$ 13,090.00	H2E	17.135
NF303-6PB6B	\$ 1,770.00	H1E	17.135	NF323-3PBJA	\$ 279.00	H1E	17.130	NF400P-2PB4A	\$ 5,400.00	H2E	17.133
NF304-3BB8B	\$ 2,800.00	H1E	17.137	NF323-3TB8A	\$ 954.00	H1E	17.136	NF400P-3B6A	\$ 18,660.00	H2E	17.137
NF304-3MB6B	\$ 2,170.00	H1E	17.138	NF323-4PB6A	\$ 384.00	H1E	17.134	NF400P-3MB4A	\$ 12,360.00	H2E	17.138
NF304-3PB6B	\$ 1,090.00	H1E	17.130	NF323-6PB6A	\$ 758.00	H1E	17.135	NF400P-3PB4A	\$ 6,000.00	H2E	17.131
NF304-3TB8B	\$ 2,400.00	H1E	17.136	NF324-3BB8A	\$ 1,600.00	H1E	17.137	NF400P-3TB4A	\$ 12,560.00	H2E	17.136
NF304-4PB6B	\$ 1,200.00	H1E	17.134	NF324-3MB6A	\$ 1,170.00	H1E	17.138	NF400P-4PB4A	\$ 7,500.00	H2E	17.134
NF304-6PB6B	\$ 2,110.00	H1E	17.135	NF324-3PB6A	\$ 495.00	H1E	17.130	NF400P-6P8A	\$ 12,360.00	H2E	17.135
NF307-3P	\$ 2,800.00	H2E	17.131	NF324-3TB8A	\$ 1,260.00	H1E	17.136	NF400X-2PB4A	\$ 7,200.00	H2E	17.133
NF307-3T	\$ 5,600.00	H1E	17.136	NF324-4PB6A	\$ 545.00	H1E	17.134	NF400X-3B6A	\$ 24,660.00	H2E	17.137
NF307-4P	\$ 3,050.00	H1E	17.134	NF324-6PB6A	\$ 1,110.00	H1E	17.135	NF400X-3MB4A	\$ 16,420.00	H2E	17.138
NF307-6P	\$ 3,050.00	H1E	17.135	NF327-3P	\$ 2,000.00	H1E	17.131	NF400X-3PB4A	\$ 8,000.00	H2E	17.130
NF30E-3PB6A	\$ 560.00	H2E	17.131	NF327-3T	\$ 4,300.00	H1E	17.136	NF400X-3TB4A	\$ 16,560.00	H2E	17.136
NF30E-4PB4B	\$ 650.00	H1E	17.134	NF327-4P	\$ 2,100.00	H1E	17.134	NF400X-4PB4A	\$ 10,000.00	H2E	17.134
NF30E-6PB6B	\$ 1,230.00	H1E	17.135	NF327-6P	\$ 4,600.00	H1E	17.135	NF400X-6P8A	\$ 16,360.00	H2E	17.135
NF30P-3BB8B	\$ 2,400.00	H1E	17.137	NF32E-3PB4B	\$ 255.00	H1E	17.131	NF451-3BB8B	\$ 1,215.00	H1E	17.137
NF30P-3MB6B	\$ 1,900.00	H1E	17.138	NF32E-3PBJA	\$ 225.00	H1E	17.131	NF451-3MB6B	\$ 750.00	H1E	17.138
NF30P-3PB6B	\$ 875.00	H1E	17.131	NF32E-3PBJB	\$ 230.00	H1E	17.131	NF451-3PB6B	\$ 295.00	H1E	17.130
NF30P-3TB8B	\$ 2,000.00	H1E	17.136	NF32E-4PBJB	\$ 265.00	H1E	17.134	NF451-3PBJB	\$ 245.00	H1E	17.130
NF30P-4PB6B	\$ 1,100.00	H1E	17.134	NF32E-6PBJB	\$ 450.00	H1E	17.135	NF451-3TB8B	\$ 870.00	H1E	17.136
NF30P-6PB6B	\$ 1,900.00	H1E	17.135	NF32P-3BB8A	\$ 1,350.00	H1E	17.137	NF451-4PB6B	\$ 360.00	H1E	17.134
NF30X-3BB8B	\$ 4,800.00	H1E	17.137	NF32P-3MB6A	\$ 890.00	H1E	17.138	NF451-6PB6B	\$ 690.00	H1E	17.135
NF30X-3MB6B	\$ 2,700.00	H1E	17.138	NF32P-3PB6A	\$ 365.00	H1E	17.131	NF452-3BB8B	\$ 1,312.00	H1E	17.137
NF30X-3PB6B	\$ 1,200.00	H1E	17.130	NF32P-3PBJA	\$ 315.00	H1E	17.131	NF452-3MB6B	\$ 908.00	H1E	17.138
NF30X-3TB8B	\$ 3,900.00	H1E	17.136	NF32P-3TB8A	\$ 1,100.00	H1E	17.136	NF452-3PB6B	\$ 370.00	H1E	17.131
NF30X-4PB6B	\$ 1,525.00	H1E	17.134	NF32P-4PB6A	\$ 420.00	H1E	17.134	NF452-3PBJB	\$ 320.00	H1E	17.131
NF30X-6PB6B	\$ 2,660.00	H1E	17.135	NF32P-6PB6A	\$ 830.00	H1E	17.135	NF452-3TB8B	\$ 1,018.00	H1E	17.136
NF31501-2P8A	\$ 25,200.00	H3E	17.133	NF32X-3BB8A	\$ 3,900.00	H1E	17.137	NF452-4PB6B	\$ 434.00	H1E	17.134
NF31501-3P8A	\$ 28,000.00	H3E	17.130	NF32X-3MB6A	\$ 1,440.00	H1E	17.138	NF452-6PB6B	\$ 838.00	H1E	17.135
NF31501-4P8A	\$ 35,000.00	H3E	17.134	NF32X-3PB6A	\$ 605.00	H1E	17.130	NF453-3BB8B	\$ 1,312.00	H1E	17.137
NF31502-2P8A	\$ 25,560.00	H3E	17.133	NF32X-3TB8A	\$ 1,950.00	H1E	17.136	NF453-3MB6B	\$ 908.00	H1E	17.138
NF31502-3P8A	\$ 28,400.00	H3E	17.131	NF32X-4PB6A	\$ 680.00	H1E	17.134	NF453-3PB6B	\$ 370.00	H1E	17.130
NF31502-4P8A	\$ 35,500.00	H3E	17.134	NF32X-6PB6A	\$ 1,380.00	H1E	17.135	NF453-3PBJB	\$ 320.00	H1E	17.130
NF31503-2P8A	\$ 27,000.00	H3E	17.133	NF4001-2PB4A	\$ 2,340.00	H2E	17.133	NF453-3TB8B	\$ 1,018.00	H1E	17.136
NF31503-3P8A	\$ 30,000.00	H3E	17.130	NF4001-3B6A	\$ 8,460.00	H2E	17.137	NF453-4PB6B	\$ 434.00	H1E	17.134
NF31503-4P8A	\$ 37,500.00	H3E	17.134	NF4001-3MB4A	\$ 5,920.00	H2E	17.138	NF453-6PB6B	\$ 838.00	H1E	17.135
NF31504-2P8A	\$ 35,280.00	H3E	17.133	NF4001-3PB4A	\$ 2,600.00	H2E	17.130	NF454-3BB8B	\$ 1,750.00	H1E	17.137
NF31504-3P8A	\$ 39,200.00	H3E	17.130	NF4001-3TB4A	\$ 5,960.00	H2E	17.136	NF454-3MB6B	\$ 1,200.00	H1E	17.138
NF31504-4P8A	\$ 49,000.00	H3E	17.134	NF4001-4PB4A	\$ 3,250.00	H2E	17.134	NF454-3PB6B	\$ 525.00	H1E	17.130
NF3150P-2P8A	\$ 37,800.00	H3E	17.133	NF4001-6P8A	\$ 5,860.00	H2E	17.135	NF454-3TB8B	\$ 1,340.00	H1E	17.136
NF3150P-3P8A	\$ 42,000.00	H3E	17.131	NF4002-2PB4A	\$ 2,610.00	H2E	17.133	NF454-4PB6B	\$ 570.00	H1E	17.134
NF3150P-4P8A	\$ 52,500.00	H3E	17.134	NF4002-3B6A	\$ 9,360.00	H2E	17.137	NF454-6PB6B	\$ 1,140.00	H1E	17.135
NF3150X-3P8A	\$ 49,000.00	H3E	17.130	NF4002-3MB4A	\$ 6,030.00	H2E	17.138	NF457-3P	\$ 2,100.00	H1E	17.131
NF3150X-4P8A	\$ 61,250.00	H3E	17.134	NF4002-3PB4A	\$ 2,900.00	H2E	17.131	NF457-3T	\$ 4,400.00	H1E	17.136
NF321-3BB8A	\$ 1,090.00	H1E	17.137	NF4002-3TB4A	\$ 6,460.00	H2E	17.136	NF457-4P	\$ 2,200.00	H1E	17.134
NF321-3MB6A	\$ 670.00	H1E	17.138	NF4002-4PB4A	\$ 3,625.00	H2E	17.134	NF457-6P	\$ 4,800.00	H1E	17.135
NF321-3PB6A	\$ 255.00	H1E	17.130	NF4002-6P8A	\$ 6,160.00	H2E	17.135	NF45E-3PB4B	\$ 295.00	H1E	17.131
NF321-3PFJA	\$ 205.00	H1E	17.130	NF4003-2PB4A	\$ 2,520.00	H2E	17.133	NF45E-3PBJA	\$ 245.00	H1E	17.131
NF321-3TB8A	\$ 790.00	H1E	17.136	NF4003-3B6A	\$ 9,060.00	H2E	17.137	NF45E-4PBJA	\$ 300.00	H1E	17.134
NF321-4PB6A	\$ 310.00	H1E	17.134	NF4003-3MB4A	\$ 6,030.00	H2E	17.138	NF45E-6PBJB	\$ 520.00	H1E	17.135
NF321-6PB6A	\$ 610.00	H1E	17.135	NF4003-3PB4A	\$ 2,800.00	H2E	17.130	NF45P-3BB8B	\$ 1,420.00	H1E	17.137
NF322-3BB8A	\$ 1,297.00	H1E	17.137	NF4003-3TB4A	\$ 6,160.00	H2E	17.136	NF45P-3MB6B	\$ 990.00	H1E	17.138
NF322-3MB6A	\$ 818.00	H1E	17.138	NF4003-4PB4A	\$ 3,500.00	H2E	17.134	NF45P-3PB6B	\$ 400.00	H1E	17.131
NF322-3PB6A	\$ 329.00	H1E	17.131	NF4003-6P8A	\$ 5,960.00	H2E	17.135	NF45P-3PBJB	\$ 350.00	H1E	17.131
NF322-3PBJA	\$ 279.00	H1E	17.131	NF4004-2PB4A	\$ 5,750.00	H2E	17.133	NF45P-3TB8B	\$ 1,180.00	H1E	17.136
NF322-3TB8A	\$ 938.00	H1E	17.136	NF4004-3MB4A	\$ 19,750.00	H2E	17.137	NF45P-4PB6B	\$ 465.00	H1E	17.134
NF322-4PB6A	\$ 384.00	H1E	17.134	NF4004-3PB4A	\$ 13,150.00	H2E	17.138	NF45P-6PB6B	\$ 930.00	H1E	17.135

NF45X-3BB8B – NF800X-6P8A

Catalog number	List price	Discount schedule	Page number	Catalog number	List price	Discount schedule	Page number	Catalog number	List price	Discount schedule	Page number
NF45X-3BB8B	\$ 4,050.00	H1E	17.137	NF603-3BB8B	\$ 2,400.00	H1E	17.137	NF637-4P	\$ 2,500.00	H1E	17.134
NF45X-3MB6B	\$ 1,490.00	H1E	17.138	NF603-3MB6B	\$ 1,880.00	H1E	17.138	NF637-6P	\$ 5,000.00	H1E	17.135
NF45X-3PB6B	\$ 635.00	H1E	17.130	NF603-3PB6B	\$ 830.00	H1E	17.130	NF63E-3PB4B	\$ 325.00	H2E	17.131
NF45X-3TB8B	\$ 3,500.00	H1E	17.136	NF603-3TB8B	\$ 1,880.00	H1E	17.136	NF63E-3PBJA	\$ 275.00	H1E	17.131
NF45X-4PB6B	\$ 700.00	H1E	17.134	NF603-4PB6B	\$ 1,038.00	H1E	17.134	NF63E-4PBJA	\$ 410.00	H1E	17.134
NF45X-6PB6B	\$ 1,430.00	H1E	17.135	NF603-6PB6B	\$ 1,820.00	H1E	17.135	NF63E-6PBJB	\$ 770.00	H1E	17.135
NF6001-2PB4A	\$ 4,320.00	H2E	17.133	NF604-3BB8B	\$ 2,900.00	H1E	17.137	NF63P-3BB8A	\$ 1,550.00	H1E	17.137
NF6001-3B6A	\$ 15,060.00	H2E	17.137	NF604-3MB6B	\$ 2,210.00	H1E	17.138	NF63P-3MB6A	\$ 1,090.00	H1E	17.138
NF6001-3MB4A	\$ 10,020.00	H2E	17.138	NF604-3PB6B	\$ 1,140.00	H1E	17.130	NF63P-3PB6A	\$ 430.00	H1E	17.131
NF6001-3PB4A	\$ 4,800.00	H2E	17.130	NF604-3TB8B	\$ 2,450.00	H1E	17.136	NF63P-3PBJA	\$ 380.00	H1E	17.131
NF6001-3TB4A	\$ 10,260.00	H2E	17.136	NF604-4PB6B	\$ 1,250.00	H1E	17.134	NF63P-3TB8A	\$ 1,260.00	H1E	17.136
NF6001-4PB4A	\$ 6,000.00	H2E	17.134	NF604-6PB6B	\$ 2,160.00	H1E	17.135	NF63P-4PB6A	\$ 510.00	H1E	17.134
NF6001-6P8A	\$ 9,960.00	H2E	17.135	NF607-3P	\$ 2,850.00	H2E	17.131	NF63P-6PB6A	\$ 1,030.00	H1E	17.135
NF6002-2PB4A	\$ 4,590.00	H2E	17.133	NF607-3T	\$ 5,700.00	H1E	17.136	NF63X-3BB8A	\$ 4,150.00	H1E	17.137
NF6002-3B6A	\$ 15,960.00	H2E	17.137	NF607-4P	\$ 3,100.00	H1E	17.134	NF63X-3MB6A	\$ 1,540.00	H1E	17.138
NF6002-3MB4A	\$ 10,420.00	H2E	17.138	NF607-6P	\$ 3,100.00	H1E	17.135	NF63X-3PB6A	\$ 660.00	H1E	17.130
NF6002-3PB4A	\$ 5,100.00	H2E	17.131	NF60E-3PB6A	\$ 610.00	H2E	17.131	NF63X-3TB8A	\$ 3,600.00	H1E	17.136
NF6002-3TB4A	\$ 10,760.00	H2E	17.136	NF60E-4PB4B	\$ 700.00	H1E	17.134	NF63X-4PB6A	\$ 740.00	H1E	17.134
NF6002-4PB4A	\$ 6,375.00	H2E	17.134	NF60E-6PB6B	\$ 1,280.00	H1E	17.135	NF63X-6PB6A	\$ 1,480.00	H1E	17.135
NF6002-6P8A	\$ 10,560.00	H2E	17.135	NF60P-3BB8B	\$ 2,500.00	H1E	17.137	NF8001-2PB4A	\$ 7,200.00	H2E	17.133
NF6003-2PB4A	\$ 4,500.00	H2E	17.133	NF60P-3MB6B	\$ 1,950.00	H1E	17.138	NF8001-3B6A	\$ 24,660.00	H2E	17.137
NF6003-3B6A	\$ 15,660.00	H2E	17.137	NF60P-3PB6B	\$ 925.00	H1E	17.131	NF8001-3MB4A	\$ 16,420.00	H2E	17.138
NF6003-3MB4A	\$ 10,420.00	H2E	17.138	NF60P-3TB8B	\$ 2,050.00	H1E	17.136	NF8001-3PB4A	\$ 8,000.00	H2E	17.130
NF6003-3PB4A	\$ 5,000.00	H2E	17.130	NF60P-4PB6B	\$ 1,150.00	H1E	17.134	NF8001-3TB4A	\$ 16,660.00	H2E	17.136
NF6003-3TB4A	\$ 10,660.00	H2E	17.136	NF60P-6PB6B	\$ 1,950.00	H1E	17.135	NF8001-4PB4A	\$ 10,000.00	H2E	17.134
NF6003-4PB4A	\$ 6,250.00	H2E	17.134	NF60X-3BB8B	\$ 4,900.00	H1E	17.137	NF8001-6P8A	\$ 16,360.00	H2E	17.135
NF6003-6P8A	\$ 10,360.00	H2E	17.135	NF60X-3MB6B	\$ 2,770.00	H1E	17.138	NF8002-2PB4A	\$ 7,560.00	H2E	17.133
NF6004-2PB4A	\$ 8,640.00	H2E	17.133	NF60X-3PB6B	\$ 1,250.00	H1E	17.130	NF8002-3B6A	\$ 25,860.00	H2E	17.137
NF6004-3B6A	\$ 29,330.00	H2E	17.137	NF60X-3TB8B	\$ 3,950.00	H1E	17.136	NF8002-3MB4A	\$ 19,860.00	H2E	17.138
NF6004-3MB4A	\$ 19,550.00	H2E	17.138	NF60X-4PB6B	\$ 1,575.00	H1E	17.134	NF8002-3PB4A	\$ 8,400.00	H2E	17.131
NF6004-3PB4A	\$ 9,600.00	H2E	17.130	NF60X-6PB6B	\$ 2,710.00	H1E	17.135	NF8002-3TB4A	\$ 17,460.00	H2E	17.136
NF6004-3TB4A	\$ 19,730.00	H2E	17.136	NF631-3BB8A	\$ 1,340.00	H1E	17.137	NF8002-4PB4A	\$ 10,500.00	H2E	17.134
NF6004-4PB4A	\$ 12,000.00	H2E	17.134	NF631-3MB6A	\$ 830.00	H1E	17.138	NF8002-6P8A	\$ 17,800.00	H2E	17.135
NF6004-6P8A	\$ 19,490.00	H2E	17.135	NF631-3PB6A	\$ 330.00	H1E	17.130	NF8003-2PB4A	\$ 8,460.00	H2E	17.133
NF600P-2PB4A	\$ 9,000.00	H2E	17.133	NF631-3PBJA	\$ 280.00	H1E	17.130	NF8003-3B6A	\$ 28,860.00	H2E	17.137
NF600P-3B6A	\$ 30,660.00	H2E	17.137	NF631-3TB8A	\$ 950.00	H1E	17.136	NF8003-3MB4A	\$ 19,860.00	H2E	17.138
NF600P-3MB4A	\$ 20,360.00	H2E	17.138	NF631-4PB6A	\$ 410.00	H1E	17.134	NF8003-3PB4A	\$ 9,400.00	H2E	17.130
NF600P-3PB4A	\$ 10,000.00	H2E	17.131	NF631-6PB6A	\$ 770.00	H1E	17.135	NF8003-3TB4A	\$ 19,460.00	H2E	17.136
NF600P-3TB4A	\$ 20,660.00	H2E	17.136	NF632-3BB8A	\$ 1,432.00	H1E	17.137	NF8003-4PB4A	\$ 11,750.00	H2E	17.134
NF600P-4PB4A	\$ 12,500.00	H2E	17.134	NF632-3MB6A	\$ 978.00	H1E	17.138	NF8003-6PB4A	\$ 19,800.00	H2E	17.135
NF600P-6P8A	\$ 20,360.00	H2E	17.135	NF632-3PB6A	\$ 400.00	H1E	17.131	NF8004-2PB4A	\$ 13,680.00	H2E	17.133
NF600X-2PB4A	\$ 10,800.00	H2E	17.133	NF632-3PBJA	\$ 354.00	H1E	17.131	NF8004-3B6A	\$ 46,130.00	H2E	17.137
NF600X-3B6A	\$ 36,660.00	H2E	17.137	NF632-3TB8A	\$ 1,098.00	H1E	17.136	NF8004-3MB4A	\$ 30,750.00	H2E	17.138
NF600X-3MB4A	\$ 24,420.00	H2E	17.138	NF632-4PB6A	\$ 484.00	H1E	17.134	NF8004-3PB4A	\$ 15,200.00	H2E	17.130
NF600X-3PB4A	\$ 12,000.00	H2E	17.130	NF632-6PB6A	\$ 918.00	H1E	17.135	NF8004-3TB4A	\$ 30,920.00	H2E	17.136
NF600X-3TB4A	\$ 24,660.00	H2E	17.136	NF633-3BB8A	\$ 1,432.00	H1E	17.137	NF8004-4PB4A	\$ 19,000.00	H2E	17.134
NF600X-4PB4A	\$ 15,000.00	H2E	17.134	NF633-3MB6A	\$ 978.00	H1E	17.138	NF8004-6P8A	\$ 30,690.00	H2E	17.135
NF600X-6P8A	\$ 24,360.00	H2E	17.135	NF633-3PB6A	\$ 404.00	H1E	17.130	NF800P-2PB4A	\$ 14,400.00	H2E	17.133
NF601-3BB8B	\$ 2,070.00	H1E	17.137	NF633-3PBJA	\$ 354.00	H1E	17.130	NF800P-3B6A	\$ 48,660.00	H2E	17.137
NF601-3MB6B	\$ 1,340.00	H1E	17.138	NF633-3TB8A	\$ 1,098.00	H1E	17.136	NF800P-3MB4A	\$ 32,360.00	H2E	17.138
NF601-3PB6B	\$ 560.00	H1E	17.130	NF633-4PB6A	\$ 484.00	H1E	17.134	NF800P-3PB4A	\$ 16,000.00	H3E	17.131
NF601-3TB8B	\$ 1,460.00	H1E	17.136	NF633-6PB6A	\$ 918.00	H1E	17.135	NF800P-4PB4A	\$ 20,000.00	H2E	17.134
NF601-4PB6B	\$ 700.00	H1E	17.134	NF634-3BB8A	\$ 1,850.00	H1E	17.137	NF800P-6P8A	\$ 32,360.00	H2E	17.135
NF601-6PB6B	\$ 1,280.00	H1E	17.135	NF634-3MB6A	\$ 1,245.00	H1E	17.138	NF800P-TB34A	\$ 32,660.00	H2E	17.136
NF602-3BB8B	\$ 2,400.00	H1E	17.137	NF634-3PB6A	\$ 550.00	H1E	17.130	NF800X-2PB4A	\$ 17,100.00	H2E	17.133
NF602-3MB6B	\$ 1,880.00	H1E	17.138	NF634-3TB8A	\$ 1,420.00	H1E	17.136	NF800X-3MB4A	\$ 38,420.00	H2E	17.138
NF602-3PB6B	\$ 830.00	H2E	17.131	NF634-4PB6A	\$ 595.00	H1E	17.134	NF800X-3PB4A	\$ 19,000.00	H2E	17.130
NF602-3TB8B	\$ 1,830.00	H1E	17.136	NF634-6PB6A	\$ 1,185.00	H1E	17.135	NF800X-3TB4A	\$ 38,660.00	H2E	17.136
NF602-4PB6B	\$ 975.00	H1E	17.134	NF637-3P	\$ 2,400.00	H1E	17.131	NF800X-4PB4A	\$ 23,750.00	H2E	17.134
NF602-6PB6B	\$ 1,720.00	H1E	17.135	NF637-3T	\$ 4,500.00	H1E	17.136	NF800X-6P8A	\$ 38,360.00	H2E	17.135

NF800X-8B6A – OHY65L5E011

Alphanumeric

0

Catalog number	List price	Discount schedule	Page number	Catalog number	List price	Discount schedule	Page number	Catalog number	List price	Discount schedule	Page number
NF800X-8B6A	\$ 57,660.00	H2E	17.137	OESA-ZX167	\$ 56.00	H6	17.21	OFMZ4	\$ 70.00	H6	17.104
NL22E-86	\$ 72.00	KCN	7.5	OESA250RD3	\$ 1,380.00	H5	17.100	OHB125J10	\$ 90.00	SH	15.59
NL31E-86	\$ 72.00	KCN	7.5	OESA250RD4	\$ 1,840.00	H5	17.100	OHB125L10	\$ 130.00	SH	15.59
NL40E-86	\$ 72.00	KCN	7.5	OESA400RD3	\$ 1,860.00	H5	17.100	OHB145J12	\$ 80.00	H6	17.96
NL44E-86	\$ 144.00	KCN	7.5	OESA400RD4	\$ 2,480.00	H5	17.100	OHB175J10	\$ 100.00	SH	15.59
NL53E-86	\$ 144.00	KCN	7.5	OESA630RD3	\$ 2,900.00	H5	17.100	OHB175L10	\$ 140.00	SH	15.59
NL62E-86	\$ 144.00	KCN	7.5	OESA630RD4	\$ 3,860.00	H5	17.100	OHB1AH1	\$ 22.00	H6	17.10
NL71E-86	\$ 144.00	KCN	7.5	OESA800RD3	\$ 4,760.00	H5	17.100	OHB1PH	\$ 22.00	H6	17.17
NL80E-86	\$ 144.00	KCN	7.5	OESA800RD4	\$ 6,340.00	H5	17.100	OHB1RH	\$ 22.00	H6	17.17
OA1G01	\$ 20.00	H6	17.18	OESAXZ1-S10/4	\$ 290.00	H6	17.99	OHB2AJ	\$ 30.00	H6	5.5
OA1G10	\$ 20.00	H6	17.18	OESAXZ1-S11/4	\$ 290.00	H6	17.99	OHB2AJ1	\$ 28.00	H6	17.10
OA2G11	\$ 40.00	H6	17.21	OESAXZ1-S3/4	\$ 290.00	H6	17.99	OHB2AJE011	\$ 40.00	H6	17.16
OAZX1	\$ 20.00	H6	17.21	OESAXZ1-S10	\$ 220.00	H6	17.99	OHB2PJ	\$ 28.00	H6	17.17
OBEA-01	\$ 28.00	H6	17.21	OESAXZ1-S11	\$ 220.00	H6	17.99	OHB2RJ	\$ 28.00	H6	17.17
OBEA-01AU	\$ 56.00	H6	17.21	OESAXZ1-S2	\$ 220.00	H6	17.99	OHB3AH1	\$ 24.00	H6	17.10
OBEA-10	\$ 28.00	H6	17.21	OESAXZ1-S2/4	\$ 290.00	H6	17.99	OHB3PH	\$ 24.00	H6	17.17
OBEA-10AU	\$ 56.00	H6	17.21	OESAXZ1-S3	\$ 220.00	H6	17.99	OHB3RH	\$ 24.00	H6	17.17
OBEA-ZX01	\$ 32.00	H6	17.21	OESAXZ1-S4	\$ 220.00	H6	17.99	OHB45J10	\$ 20.00	SH	15.59
OBEA-ZX10	\$ 32.00	H6	17.21	OESAXZ1-S4/4	\$ 290.00	H6	17.99	OHB45J5	\$ 70.00	H6	17.11
OEMO002/240VAC	\$ 6,514.00	H6	17.105	OESAXZ1-S5	\$ 220.00	H6	17.99	OHB45L10	\$ 110.00	SH	15.59
OEMO002/110VAC	\$ 6,514.00	H6	17.105	OESAXZ1-S5/4	\$ 290.00	H6	17.99	OHB65J10	\$ 70.00	SH	15.59
OEMO002/220VAC	\$ 6,514.00	H6	17.105	OESAXZ1-S6	\$ 220.00	H6	17.99	OHB65J5	\$ 80.00	H6	17.11
OEMO002/220VDC	\$ 6,514.00	H6	17.105	OESAXZ1-S6/4	\$ 290.00	H6	17.99	OHB65J5E011	\$ 90.00	H6	17.16
OEMO003/230VAC	\$ 6,514.00	H6	17.105	OESAXZ1-S7	\$ 220.00	H6	17.99	OHB65J6	\$ 80.00	H6	17.15
OEMO002/24VDCAC	\$ 6,514.00	H6	17.105	OESAXZ1-S7/4	\$ 290.00	H6	17.99	OHB65L10	\$ 110.00	SH	15.59
OEMO002/48VDCAC	\$ 6,514.00	H6	17.105	OESAXZ1-S8	\$ 220.00	H6	17.99	OHB65L5	\$ 120.00	H6	17.11
OEMO003/110VAC	\$ 7,644.00	H6	17.105	OESAXZ1-S8/4	\$ 290.00	H6	17.99	OHB65L5E011	\$ 130.00	H6	17.16
OEMO003/110VDC	\$ 7,644.00	H6	17.105	OESAXZ1-S9	\$ 220.00	H6	17.99	OHB66J6	\$ 80.00	H6	15.139
OEMO003/220VAC	\$ 7,644.00	H6	17.105	OESAXZ1-S9/4	\$ 290.00	H6	17.99	OHB80J6	\$ 90.00	H6	17.15
OEMO003/220VDC	\$ 7,644.00	H6	17.105	OESAXZ2-S2	\$ 400.00	H6	17.99	OHB80L6	\$ 130.00	H6	15.139
OEMO003/230VAC	\$ 7,644.00	H6	17.105	OESAXZ2-S2/4	\$ 530.00	H6	17.99	OHB95J10	\$ 80.00	SH	15.59
OEMO003/240VAC	\$ 7,644.00	H6	17.105	OESAXZ2-S3	\$ 400.00	H6	17.99	OHB95L10	\$ 120.00	SH	15.59
OEMO003/24VDCAC	\$ 7,644.00	H6	17.105	OESAXZ2-S3/4	\$ 530.00	H6	17.99	OHG125J10	\$ 90.00	SH	15.59
OEMO003/48VDCAC	\$ 7,644.00	H6	17.105	OESAXZ2-S4	\$ 400.00	H6	17.99	OHG125L10	\$ 130.00	SH	15.59
OEMO202/110VAC	\$ 7,644.00	H6	17.105	OESAXZ2-S4/4	\$ 530.00	H6	17.99	OHG175J10	\$ 100.00	SH	15.59
OEMO202/220VAC	\$ 7,644.00	H6	17.105	OESAXZ2-S5	\$ 400.00	H6	17.99	OHG175L10	\$ 140.00	SH	15.59
OEMO202/220VDC	\$ 7,644.00	H6	17.105	OESAXZ2-S5/4	\$ 530.00	H6	17.99	OHG45J10	\$ 70.00	SH	15.59
OEMO202/240VAC	\$ 7,644.00	H6	17.105	OESAXZ2-S6	\$ 400.00	H6	17.99	OHG45L10	\$ 110.00	SH	15.59
OEMO202/24VDCAC	\$ 7,644.00	H6	17.105	OESAXZ2-S6/4	\$ 530.00	H6	17.99	OHG65J10	\$ 70.00	SH	15.59
OEMO202/48VDCAC	\$ 7,644.00	H6	17.105	OETL-ZK19	\$ 40.00	H6	17.22	OHG65L10	\$ 110.00	SH	15.59
OEMO303/110VAC	\$ 9,490.00	H6	17.105	OETL-ZT100	\$ 40.00	H6	17.29	OHG95J10	\$ 80.00	SH	15.59
OEMO303/220VAC	\$ 9,490.00	H6	17.105	OETL-ZT80A	\$ 1,280.00	H6	17.29	OHG95L10	\$ 120.00	SH	15.59
OEMO303/240VAC	\$ 9,490.00	H6	17.105	OETL-ZT80L	\$ 1,220.00	H6	17.29	OHY145J12	\$ 80.00	H6	17.96
OEMO303/24VDCAC	\$ 9,490.00	H6	17.105	OETL-ZW12	\$ 560.00	H6	17.95	OHY1AH1	\$ 22.00	H6	17.10
OEMO303/48VDCAC	\$ 9,490.00	H6	17.105	OETL-ZW13	\$ 560.00	H6	17.95	OHY1PH	\$ 22.00	H6	17.17
OEMOZX1	\$ 400.00	H6	17.105	OETL-ZW14	\$ 140.00	H6	17.95	OHY1RH	\$ 22.00	H6	17.17
OEMOZX2	\$ 400.00	H6	17.105	OETL-ZW15	\$ 160.00	H6	17.95	OHY2AJ	\$ 30.00	H6	5.12
OES200J3-S	\$ 1,800.00	H5	17.96	OETL-ZW16	\$ 190.00	H6	17.21	OHY2AJ1	\$ 28.00	H6	17.10
OES200R03	\$ 1,220.00	H5	17.99	OETL-ZW24	\$ 80.00	H6	17.14	OHY2AJE011	\$ 40.00	H6	17.16
OES200R04	\$ 1,510.00	H5	17.99	OETL-ZW3	\$ 140.00	H6	17.95	OHY2PJ	\$ 28.00	H6	17.17
OES400J3-S	\$ 2,600.00	H5	17.96	OETL-ZW5	\$ 190.00	H6	17.29	OHY2RJ	\$ 28.00	H6	17.17
OES400R03	\$ 1,740.00	H5	17.99	OETL-ZW9	\$ 260.00	H6	17.95	OHY3AH1	\$ 24.00	H6	17.10
OES400R04	\$ 2,140.00	H5	17.99	OETL-ZX108	\$ 794.00	H6	17.29	OHY3PH	\$ 24.00	H6	17.17
OES600R03	\$ 2,640.00	H5	17.99	OETL-ZX58	\$ 14.00	H6	17.13	OHY3RH	\$ 24.00	H6	17.17
OES600R04	\$ 3,270.00	H5	17.99	OETL-ZX74	\$ 190.00	H6	17.96	OHY45J5	\$ 70.00	H6	17.11
OES800R04	\$ 5,710.00	H5	17.99	OETL-ZX95	\$ 100.00	H6	17.21	OHY65J5	\$ 80.00	H6	17.11
OES800R03	\$ 4,590.00	H5	17.99	OEZNP1	\$ 20.00	H6	17.21	OHY65J5E011	\$ 90.00	H6	17.16
OESA-ZW1	\$ 300.00	H6	17.22	OFM240	\$ 290.00	H6	17.104	OHY65J6	\$ 80.00	H6	17.15
OESA-ZW1X	\$ 340.00	H6	17.22	OFM600	\$ 290.00	H6	17.104	OHY65L5	\$ 120.00	H6	17.11
OESA-ZW2	\$ 220.00	H6	17.22	OFMZ4	\$ 20.00	H6	17.104	OHY65L5E011	\$ 130.00	H6	17.16

OHY66J6 – OPY1EN1

Catalog number	List price	Discount schedule	Page number	Catalog number	List price	Discount schedule	Page number	Catalog number	List price	Discount schedule	Page number
OHY66J6	\$ 80.00	H6	15.139	OMURR1PB	\$ 55.00	CX	11.5	ONSO43PB	\$ 85.00	CX	11.7
OHY7	\$ 28.00	H6	17.11	OMURR3PB	\$ 70.00	CX	11.5	ONSO51PB	\$ 65.00	CX	11.8
OHY80J6	\$ 90.00	H6	17.15	OMV30PB	\$ 75.00	CX	11.9	ONSO52PB	\$ 75.00	CX	11.8
OHY80L6	\$ 130.00	H6	15.139	OMV32PB	\$ 75.00	CX	11.9	ONST301M	\$ 45.00	CX	11.6
OHZX5	\$ 24.00	H6	17.21	OMV3PB	\$ 50.00	CX	11.6	ONST301PB	\$ 45.00	CX	11.6
OHZX6	\$ 20.00	H6	17.17	OMVN30PB	\$ 70.00	CX	11.8	ONST31M	\$ 40.00	CX	11.4
OMA01KB	\$ 50.00	CX	11.2	OMVN3PB	\$ 45.00	CX	11.4	ONST31PB	\$ 40.00	CX	11.4
OMA01PB	\$ 30.00	CX	11.2	OMWS1PB	\$ 30.00	CX	11.3	ONST32PB	\$ 50.00	CX	11.4
OMA02PB	\$ 35.00	CX	11.2	OMWS2PB	\$ 40.00	CX	11.3	ONST33PB	\$ 70.00	CX	11.4
OMA03KB	\$ 60.00	CX	11.2	OMWS3PB	\$ 50.00	CX	11.3	ONST34PB	\$ 90.00	CX	11.4
OMA03PB	\$ 40.00	CX	11.2	OMWS4PB	\$ 60.00	CX	11.3	ONST41PB	\$ 50.00	CX	11.6
OMA04PB	\$ 45.00	CX	11.2	OMX99	\$ 2.60	CX	11.10	ONST42PB	\$ 70.00	CX	11.6
OMA05PB	\$ 50.00	CX	11.2	ONA01KB	\$ 60.00	CX	11.2	ONST43PB	\$ 85.00	CX	11.6
OMA06PB	\$ 60.00	CX	11.2	ONA01M	\$ 50.00	CX	11.2	ONST51PB	\$ 65.00	CX	11.7
OMA1KB	\$ 50.00	CX	11.2	ONA01PB	\$ 40.00	CX	11.2	ONST52PB	\$ 75.00	CX	11.7
OMA1PB	\$ 30.00	CX	11.2	ONA02M	\$ 60.00	CX	11.2	ONU1KB	\$ 65.00	CX	11.5
OMA2PB	\$ 35.00	CX	11.2	ONA02PB	\$ 45.00	CX	11.2	ONU1M	\$ 70.00	CX	11.5
OMA3KB	\$ 60.00	CX	11.2	ONA03KB	\$ 70.00	CX	11.2	ONU1PB	\$ 70.00	CX	11.5
OMA3PB	\$ 40.00	CX	11.2	ONA03M	\$ 70.00	CX	11.2	ONU2M	\$ 80.00	CX	11.5
OMA4PB	\$ 45.00	CX	11.2	ONA03PB	\$ 50.00	CX	11.2	ONU2PB	\$ 80.00	CX	11.5
OMA5PB	\$ 50.00	CX	11.2	ONA04PB	\$ 55.00	CX	11.2	ONU3KB	\$ 80.00	CX	11.5
OMA6PB	\$ 60.00	CX	11.2	ONA05PB	\$ 60.00	CX	11.2	ONU3M	\$ 90.00	CX	11.5
OMAU31PB	\$ 50.00	CX	11.6	ONA06M	\$ 80.00	CX	11.2	ONU3PB	\$ 90.00	CX	11.5
OMF101	\$ 1.70	CX	11.10	ONA06PB	\$ 70.00	CX	11.2	ONU4M	\$ 100.00	CX	11.5
OMFB72	\$ 3.00	CX	11.10	ONA1KB	\$ 60.00	CX	11.2	ONU4PB	\$ 100.00	CX	11.5
OMNX80	\$ 6.00	CX	11.10	ONA1M	\$ 50.00	CX	11.2	ONUR139M	\$ 80.00	CX	11.7
OMPB1	\$ 20.00	CX	11.10	ONA1PB	\$ 40.00	CX	11.2	ONUR139PB	\$ 75.00	CX	11.7
OMSA2PB	\$ 35.00	CX	11.2	ONA2M	\$ 60.00	CX	11.2	ONURR1M	\$ 65.00	CX	11.5
OMSE158PB	\$ 45.00	CX	11.2	ONA2PB	\$ 45.00	CX	11.2	ONURR1PB	\$ 65.00	CX	11.5
OMSE2PB	\$ 35.00	CX	11.2	ONA3KB	\$ 70.00	CX	11.2	ONURR2PB	\$ 80.00	CX	11.5
OMSEA10PB	\$ 40.00	CX	11.4	ONA3M	\$ 70.00	CX	11.2	ONURR3PB	\$ 90.00	CX	11.5
OMSO21PB	\$ 35.00	CX	11.4	ONA3PB	\$ 68.00	CX	11.2	ONV30M	\$ 80.00	CX	11.9
OMSO22PB	\$ 45.00	CX	11.4	ONA4PB	\$ 55.00	CX	11.2	ONV30PB	\$ 80.00	CX	11.9
OMSO23PB	\$ 60.00	CX	11.4	ONA5PB	\$ 60.00	CX	11.2	ONV32PB	\$ 85.00	CX	11.9
OMSO24PB	\$ 75.00	CX	11.4	ONA6M	\$ 80.00	CX	11.2	ONV3M	\$ 55.00	CX	11.6
OMSO31PB	\$ 40.00	CX	11.6	ONA6PB	\$ 70.00	CX	11.2	ONV3PB	\$ 55.00	CX	11.6
OMSO32PB	\$ 60.00	CX	11.6	ONAU31M	\$ 55.00	CX	11.6	ONVN30M	\$ 75.00	CX	11.8
OMSO33PB	\$ 75.00	CX	11.6	ONAU31PB	\$ 55.00	CX	11.6	ONVN30PB	\$ 75.00	CX	11.8
OMSO34PB	\$ 90.00	CX	11.6	ONAU32PB	\$ 60.00	CX	11.6	ONVN3M	\$ 50.00	CX	11.4
OMSO41PB	\$ 45.00	CX	11.7	ONF101	\$ 3.10	CX	11.10	ONVN3PB	\$ 50.00	CX	11.4
OMSO42PB	\$ 65.00	CX	11.7	ONFB72	\$ 7.00	CX	11.10	ONW3PB	\$ 70.00	CX	11.4
OMSO43PB	\$ 80.00	CX	11.7	ONPB1	\$ 25.00	CX	11.10	ONWS1M	\$ 40.00	CX	11.3
OMSO51PB	\$ 55.00	CX	11.8	ONSA2PB	\$ 45.00	CX	11.2	ONWS1PB	\$ 40.00	CX	11.3
OMSO52PB	\$ 65.00	CX	11.8	ONSE158M	\$ 50.00	CX	11.2	ONWS2M	\$ 50.00	CX	11.3
OMST301PB	\$ 40.00	CX	11.6	ONSE158PB	\$ 50.00	CX	11.2	ONWS2PB	\$ 50.00	CX	11.3
OMST31PB	\$ 35.00	CX	11.4	ONSE2PB	\$ 45.00	CX	11.2	ONWS3M	\$ 60.00	CX	11.3
OMST32PB	\$ 45.00	CX	11.4	ONSEA10M	\$ 45.00	CX	11.4	ONWS3PB	\$ 60.00	CX	11.3
OMST33PB	\$ 60.00	CX	11.4	ONSEA10PB	\$ 45.00	CX	11.4	ONWS4M	\$ 70.00	CX	11.3
OMST34PB	\$ 75.00	CX	11.4	ONSO21M	\$ 40.00	CX	11.4	ONWS4PB	\$ 70.00	CX	11.3
OMST41PB	\$ 40.00	CX	11.6	ONSO21PB	\$ 40.00	CX	11.4	ONZ10L2	\$ 40.00	CX	11.10
OMST42PB	\$ 60.00	CX	11.6	ONSO22PB	\$ 50.00	CX	11.4	ONZ10L4	\$ 40.00	CX	11.10
OMST43PB	\$ 75.00	CX	11.6	ONSO23PB	\$ 65.00	CX	11.4	ONZ10L6	\$ 40.00	CX	11.10
OMST51PB	\$ 55.00	CX	11.7	ONSO24PB	\$ 80.00	CX	11.4	ONZ20B	\$ 37.00	CX	11.10
OMST52PB	\$ 65.00	CX	11.7	ONSO31M	\$ 45.00	CX	11.6	ONZ20RY	\$ 37.00	CX	11.10
OMU1KB	\$ 55.00	CX	11.5	ONSO31PB	\$ 45.00	CX	11.6	OPB1	\$ 6.00	H6	17.19
OMU1PB	\$ 50.00	CX	11.5	ONSO32PB	\$ 65.00	CX	11.6	OPB1EN1	\$ 10.00	H6	17.19
OMU2PB	\$ 50.00	CX	11.5	ONSO33PB	\$ 80.00	CX	11.6	OPB2	\$ 8.00	H6	17.19
OMU3KB	\$ 70.00	CX	11.5	ONSO34PB	\$ 95.00	CX	11.6	OPB2EN1	\$ 12.00	H6	17.19
OMU3PB	\$ 60.00	CX	11.5	ONSO41PB	\$ 50.00	CX	11.7	OPY1	\$ 6.00	H6	17.19
OMU4PB	\$ 65.00	CX	11.5	ONSO42PB	\$ 70.00	CX	11.7	OPY1EN1	\$ 10.00	H6	17.19

OPY2 – OTPS60EP

Alphanumeric

0

Catalog number	List price	Discount schedule	Page number	Catalog number	List price	Discount schedule	Page number	Catalog number	List price	Discount schedule	Page number
OPY2	\$ 8.00	H6	17.19	OSC50F3	\$ 150.00	H6	17.98	OT45B6-170	\$ 196.00	H1	17.8
OPY2EN1	\$ 12.00	H6	17.19	OSC50F4	\$ 200.00	H6	17.98	OT45E3	\$ 100.00	H1	17.10
OS100JF30	\$ 690.00	H4	17.97	OSC60J3	\$ 150.00	H6	17.98	OT45E3C	\$ 328.00	H1	17.16
OS100JS30	\$ 640.00	H4	17.96	OSC60J4	\$ 200.00	H6	17.98	OT45E6	\$ 260.00	H1	17.15
OS125RF0322	\$ 700.00	H4	17.100	OSC63B3	\$ 150.00	H6	17.98	OT45ET3	\$ 104.00	H1	17.17
OS125RF0422	\$ 930.00	H4	17.100	OSC63B4	\$ 200.00	H6	17.98	OT45ET3S	\$ 132.00	H1	17.8
OS160RD03	\$ 700.00	H4	17.100	OSC63D3	\$ 150.00	H6	17.98	OT600B4-280	\$ 2,706.00	H2	17.8
OS160RD0380	\$ 700.00	H4	17.100	OSC63D4	\$ 200.00	H6	17.98	OT60B2A1-180	\$ 209.00	H1	17.8
OS160RD04	\$ 930.00	H4	17.100	OSC63F3	\$ 150.00	H6	17.98	OT60B6-170	\$ 271.00	H1	17.8
OS160RD0480	\$ 930.00	H4	17.100	OSC63F4	\$ 200.00	H6	17.98	OT60E3	\$ 175.00	H1	17.10
OS160RF0327	\$ 700.00	H4	17.100	OSZA15	\$ 200.00	ABA	1.3	OT60E3C	\$ 478.00	H1	17.16
OS160RF0427	\$ 930.00	H4	17.100	OT100B2A1-180	\$ 234.00	H1	17.8	OT60E6	\$ 410.00	H1	17.15
OS25RF1210	\$ 400.00	H4	17.100	OT100B6-170	\$ 296.00	H1	17.8	OT60ET3	\$ 179.00	H1	17.17
OS25RF2210	\$ 530.00	H4	17.100	OT100E3	\$ 200.00	H1	17.10	OT60ET3P	\$ 279.00	H1	17.8
OS30ACCF30	\$ 500.00	H4	17.97	OT100E3C	\$ 514.00	H1	17.16	OT60ET3S	\$ 207.00	H1	17.8
OS30ACCS30	\$ 360.00	H4	17.96	OT100E6	\$ 460.00	H1	17.15	OT63B2A1-180	\$ 154.00	H1	17.8
OS30AJF30	\$ 500.00	H4	17.97	OT100ET3	\$ 204.00	H1	17.17	OT63B6-170	\$ 216.00	H1	17.8
OS30AJS30	\$ 360.00	H4	17.96	OT100ET3P	\$ 304.00	H1	17.8	OT63E3	\$ 120.00	H1	17.10
OS32M12	\$ 130.00	H4	17.98	OT100ET3S	\$ 232.00	H1	17.8	OT63E3C	\$ 368.00	H1	17.16
OS32M22F	\$ 150.00	H4	17.98	OT1200B4-280	\$ 7,926.00	H3	17.8	OT63E6	\$ 300.00	H1	17.15
OS32M22N1	\$ 200.00	H4	17.98	OT1600M8-325	\$ 17,630.00	H3	17.8	OT63ET3	\$ 124.00	H1	17.17
OS32MS30	\$ 210.00	H4	17.98	OT160B6-210	\$ 516.00	H2	17.8	OT63ET3S	\$ 152.00	H1	17.8
OS32MS40F	\$ 270.00	H4	17.98	OT160E2	\$ 380.00	H2	17.20	OT800B4-280	\$ 5,066.00	H2	17.8
OS32MS40N1	\$ 320.00	H4	17.98	OT160E3	\$ 420.00	H2	17.20	OTPA116A2P1	\$ 75.00	MA	5.4
OS32RD12	\$ 500.00	H4	17.100	OT160ET3	\$ 548.00	H2	17.20	OTPA116L2P1	\$ 75.00	MA	5.4
OS32RD22	\$ 660.00	H4	17.100	OT160ET3P	\$ 640.00	H2	17.8	OTPA325A2P1	\$ 75.00	MA	5.12
OS32RF1214	\$ 400.00	H4	17.100	OT16B2A1-180	\$ 100.00	H1	17.8	OTPA325B2P1	\$ 75.00	MA	5.12
OS32RF2214	\$ 530.00	H4	17.100	OT16B6-170	\$ 162.00	H1	17.8	OTPD125ED	\$ 50.00	H6	17.18
OS60JF30	\$ 590.00	H4	17.97	OT16E3	\$ 66.00	H1	17.10	OTPD125EP	\$ 54.00	H6	17.12
OS60JS30	\$ 540.00	H4	17.96	OT16E3C	\$ 258.00	H1	17.16	OTPD32ED	\$ 28.00	H6	17.18
OS63RD12	\$ 500.00	H4	17.100	OT16E6	\$ 192.00	H1	17.15	OTPD32EP	\$ 28.00	H6	17.12
OS63RD22	\$ 660.00	H4	17.100	OT16ET3	\$ 70.00	H1	17.17	OTPD60EP	\$ 50.00	H6	17.12
OS63RF1214	\$ 500.00	H4	17.100	OT16ET3S	\$ 98.00	H1	17.8	OTPD63ED	\$ 36.00	H6	17.18
OS63RF2214	\$ 660.00	H4	17.100	OT2000M8-325	\$ 19,430.00	H3	17.8	OTPD63EP	\$ 36.00	H6	17.12
OS63X12	\$ 230.00	H4	17.98	OT200B8-240	\$ 804.00	H2	17.8	OTPE125ED	\$ 50.00	H6	17.18
OS63X22F	\$ 290.00	H4	17.98	OT25B2A1-180	\$ 106.00	H1	17.8	OTPE125EP	\$ 50.00	H6	17.12
OS63X22N1	\$ 340.00	H4	17.98	OT25B6-170	\$ 168.00	H1	17.8	OTPE160EP	\$ 100.00	H6	17.21
OS63XS30	\$ 390.00	H4	17.98	OT25E3	\$ 72.00	H1	17.10	OTPE32ED	\$ 20.00	H6	17.18
OS63XS40F	\$ 450.00	H4	17.98	OT25E3C	\$ 270.00	H1	17.16	OTPE32EP	\$ 20.00	H6	17.12
OS63XS40N1	\$ 500.00	H4	17.98	OT25E6	\$ 204.00	H1	17.15	OTPE63ED	\$ 36.00	H6	17.18
OSC16D301	\$ 150.00	H6	17.98	OT25ET3	\$ 76.00	H1	17.17	OTPE63EP	\$ 36.00	H6	17.12
OSC16D401	\$ 200.00	H6	17.98	OT25ET3S	\$ 104.00	H1	17.8	OTPL125ED	\$ 54.00	H6	17.18
OSC25F310	\$ 150.00	H6	17.98	OT30B2A1-180	\$ 184.00	H1	17.8	OTPL125EP	\$ 54.00	H6	17.12
OSC25F410	\$ 200.00	H6	17.98	OT30B6-170	\$ 246.00	H1	17.8	OTPL32ED	\$ 36.00	H6	17.18
OSC30ACCF30	\$ 150.00	H6	17.98	OT30E3	\$ 150.00	H1	17.10	OTPL32EP	\$ 36.00	H6	17.12
OSC30ACCF4	\$ 200.00	H6	17.98	OT30E3C	\$ 428.00	H1	17.16	OTPL63ED	\$ 44.00	H6	17.18
OSC30AJ3	\$ 150.00	H6	17.98	OT30E6	\$ 360.00	H1	17.15	OTPL63EP	\$ 44.00	H6	17.12
OSC30AJ4	\$ 200.00	H6	17.98	OT30ET3	\$ 154.00	H1	17.17	OTPN125ED	\$ 50.00	H6	17.18
OSC32B3A1	\$ 150.00	H6	17.98	OT30ET3P	\$ 254.00	H1	17.8	OTPN125EP	\$ 50.00	H6	17.12
OSC32B3A2	\$ 150.00	H6	17.98	OT30ET3S	\$ 182.00	H1	17.8	OTPN160EP	\$ 100.00	H6	17.21
OSC32B3E1	\$ 150.00	H6	17.98	OT3150M8-325	\$ 21,130.00	H3	17.8	OTPN32ED	\$ 20.00	H6	17.18
OSC32B3F1	\$ 150.00	H6	17.98	OT32B2A1-180	\$ 110.00	H1	17.8	OTPN32EP	\$ 20.00	H6	17.12
OSC32B4A1	\$ 200.00	H6	17.98	OT32B6-170	\$ 172.00	H1	17.8	OTPN63ED	\$ 36.00	H6	17.18
OSC32B4A2	\$ 200.00	H6	17.98	OT32E3	\$ 76.00	H1	17.10	OTPN63EP	\$ 36.00	H6	17.12
OSC32B4E1	\$ 200.00	H6	17.98	OT32E3C	\$ 288.00	H1	17.16	OTPS125ED	\$ 54.00	H6	17.18
OSC32B4F1	\$ 200.00	H6	17.98	OT32E6	\$ 212.00	H1	17.15	OTPS125EP	\$ 54.00	H6	17.12
OSC32F314	\$ 150.00	H6	17.98	OT32ET3	\$ 80.00	H1	17.17	OTPS160EP	\$ 100.00	H6	17.21
OSC32F414	\$ 200.00	H6	17.98	OT32ET3S	\$ 108.00	H1	17.8	OTPS32ED	\$ 36.00	H6	17.18
OSC35D302	\$ 150.00	H6	17.98	OT400B4-280	\$ 1,736.00	H2	17.8	OTPS32EP	\$ 36.00	H6	17.12
OSC35D402	\$ 200.00	H6	17.98	OT45B2A1-180	\$ 134.00	H1	17.8	OTPS60EP	\$ 54.00	H6	17.12

OTPS63ED – P30L1-60

Catalog number	List price	Discount schedule	Page number	Catalog number	List price	Discount schedule	Page number	Catalog number	List price	Discount schedule	Page number
OTPS63ED	\$ 44.00	H6	17.18	P105L1-60	\$ 2,940.00	PSSE	6.5	P22DB1-60K	\$ 1,835.00	PSSE	6.6
OTPS63EP	\$ 44.00	H6	17.12	P105L2-48M	\$ 3,375.00	PSSE	6.5	P22DF1-48B	\$ 1,580.00	PSSE	6.6
OTS125T1	\$ 10.00	H6	17.19	P105L2-60M	\$ 3,715.00	PSSE	6.5	P22DF1-60B	\$ 1,835.00	PSSE	6.6
OTS125T3	\$ 20.00	H6	17.19	P105LB1-48T	\$ 3,600.00	PSSE	6.6	P22L1-48	\$ 1,155.00	PSSE	6.5
OTS32T1	\$ 4.00	H6	17.19	P105LB1-60T	\$ 4,195.00	PSSE	6.6	P22L1-60	\$ 1,295.00	PSSE	6.5
OTS32T3	\$ 8.00	H6	17.19	P105LF1-48D	\$ 3,600.00	PSSE	6.6	P22L2-48M	\$ 1,480.00	PSSE	6.5
OTS63T1	\$ 6.00	H6	17.19	P105LF1-60D	\$ 4,195.00	PSSE	6.6	P22L2-60M	\$ 1,620.00	PSSE	6.5
OTS63T3	\$ 12.00	H6	17.19	P142D1-48	\$ 3,350.00	PSSE	6.5	P22LB1-48G	\$ 1,580.00	PSSE	6.6
OTZS1	\$ 13.00	H6	17.11	P142D1-60	\$ 3,800.00	PSSE	6.5	P22LB1-60G	\$ 1,835.00	PSSE	6.6
OTZS2	\$ 13.00	H6	17.22	P142D2-48M	\$ 4,225.00	PSSE	6.5	P22LF1-48B	\$ 1,580.00	PSSE	6.6
OTZW10	\$ 100.00	H6	17.22	P142D2-60M	\$ 4,675.00	PSSE	6.5	P22LF1-60B	\$ 1,835.00	PSSE	6.6
OTZW17	\$ 340.00	H6	17.14	P142DB1-48Y	\$ 4,550.00	PSSE	6.6	P24R10	\$ 305.00	F1	19.15
OTZW17X	\$ 380.00	H6	17.14	P142DB1-60Y	\$ 5,365.00	PSSE	6.6	P24R12.5	\$ 364.00	F1	19.15
OTZW6	\$ 240.00	H6	17.14	P142DF1-48E	\$ 4,550.00	PSSE	6.6	P24R14	\$ 412.00	F1	19.15
OTZW6X	\$ 280.00	H6	17.14	P142DF1-60E	\$ 5,365.00	PSSE	6.6	P24R15	\$ 434.00	F1	19.15
OTZW8	\$ 60.00	H6	17.14	P142L1-48	\$ 3,350.00	PSSE	6.5	P24R2.5	\$ 220.00	F1	19.15
OXP10X148	\$ 24.00	SH	15.59	P142L1-60	\$ 3,800.00	PSSE	6.5	P24R3.5	\$ 241.00	F1	19.15
OXP10X225	\$ 26.00	SH	15.59	P142L2-48M	\$ 4,225.00	PSSE	6.5	P24R5	\$ 273.00	F1	19.15
OXP10X500	\$ 32.00	SH	15.59	P142L2-60M	\$ 4,675.00	PSSE	6.5	P250D1-48	\$ 4,300.00	PSSE	6.5
OXP12X325	\$ 40.00	H6	17.96	P142LB1-48V	\$ 4,550.00	PSSE	6.6	P250D1-60	\$ 4,750.00	PSSE	6.5
OXP5X150	\$ 14.00	H6	17.11	P142LB1-60V	\$ 5,365.00	PSSE	6.6	P250D2-48M	\$ 5,700.00	PSSE	6.5
OXPSX150-45	\$ 14.00	H6	17.11	P142LF1-48D	\$ 4,550.00	PSSE	6.6	P250D2-60M	\$ 6,140.00	PSSE	6.5
OXPSX170	\$ 16.00	H6	17.11	P142LF1-60D	\$ 5,365.00	PSSE	6.6	P250DB1-48C	\$ 6,100.00	PSSE	6.6
OXPSX170-45	\$ 16.00	H6	17.11	P175D1-48	\$ 3,780.00	PSSE	6.5	P250DB1-60D	\$ 7,900.00	PSSE	6.6
OXPSX265	\$ 18.00	H6	17.11	P175D1-60	\$ 4,150.00	PSSE	6.5	P250DF1-48F	\$ 6,100.00	PSSE	6.6
OXPSX265-45	\$ 18.00	H6	17.11	P175D2-48M	\$ 5,180.00	PSSE	6.5	P250DF1-60F	\$ 7,900.00	PSSE	6.6
OXPSX400	\$ 30.00	H6	17.11	P175D2-60M	\$ 5,550.00	PSSE	6.5	P250L1-48	\$ 4,300.00	PSSE	6.5
OXPSX400-45	\$ 30.00	H6	17.11	P175DB1-48Z	\$ 5,580.00	PSSE	6.6	P250L1-60	\$ 4,750.00	PSSE	6.5
OXPSX500	\$ 42.00	H6	17.11	P175DB1-60Z	\$ 5,950.00	PSSE	6.6	P250L2-48M	\$ 5,700.00	PSSE	6.5
OXPSX500-45	\$ 42.00	H6	17.11	P175DF1-48E	\$ 5,580.00	PSSE	6.6	P250L2-60M	\$ 6,140.00	PSSE	6.5
OXP6X130	\$ 12.00	H6	17.15	P175DF1-60E	\$ 5,950.00	PSSE	6.6	P250LB1-48Y	\$ 6,100.00	PSSE	6.6
OXP6X130-45	\$ 12.00	H6	17.20	P175L1-48	\$ 3,780.00	PSSE	6.5	P250LB1-60Y	\$ 7,900.00	PSSE	6.6
OXP6X150	\$ 12.00	H6	17.15	P175L1-60	\$ 4,150.00	PSSE	6.5	P250LF1-48E	\$ 6,100.00	PSSE	6.6
OXP6X210	\$ 16.00	H6	17.15	P175L2-48M	\$ 5,180.00	PSSE	6.5	P250LF1-60E	\$ 7,900.00	PSSE	6.6
OXP6X210-45	\$ 16.00	H6	17.20	P175L2-60M	\$ 5,550.00	PSSE	6.5	P300D1-48	\$ 4,760.00	PSSE	6.5
OXP6X290	\$ 20.00	H6	17.15	P175LB1-48X	\$ 5,580.00	PSSE	6.6	P300D1-60	\$ 5,215.00	PSSE	6.5
OXP6X290-45	\$ 20.00	H6	17.20	P175LB1-60X	\$ 5,950.00	PSSE	6.6	P300D2-48M	\$ 6,460.00	PSSE	6.5
OXP6X360	\$ 24.00	H6	17.15	P175LF1-48E	\$ 5,580.00	PSSE	6.6	P300D2-60M	\$ 6,915.00	PSSE	6.5
OXP6X360-45	\$ 24.00	H6	17.20	P175LF1-60E	\$ 5,950.00	PSSE	6.6	P300DB1-48D	\$ 6,560.00	PSSE	6.6
OXP6X430	\$ 28.00	H6	15.139	P18D1-48	\$ 1,095.00	PSSE	6.5	P300DB1-60D	\$ 8,360.00	PSSE	6.6
OXS5X105	\$ 4.00	H6	5.12	P18D1-60	\$ 1,219.00	PSSE	6.5	P300DF1-48F	\$ 6,560.00	PSSE	6.6
OXS5X120	\$ 4.00	H6	17.16	P18D2-48M	\$ 1,395.00	PSSE	6.5	P300DF1-60F	\$ 8,360.00	PSSE	6.6
OXS5X130	\$ 6.00	H6	17.10	P18D2-60M	\$ 1,519.00	PSSE	6.5	P300L1-48	\$ 4,760.00	PSSE	6.5
OXS5X150	\$ 6.00	H6	17.16	P18DB1-48J	\$ 1,370.00	PSSE	6.6	P300L1-60	\$ 5,215.00	PSSE	6.5
OXS5X180	\$ 9.00	H6	5.12	P18DB1-60J	\$ 1,709.00	PSSE	6.6	P300L2-48M	\$ 6,460.00	PSSE	6.5
OXS5X250	\$ 12.00	H6	17.16	P18DF1-48B	\$ 1,370.00	PSSE	6.6	P300L2-60M	\$ 6,915.00	PSSE	6.5
OXS5X330	\$ 20.00	H6	17.16	P18DF1-60B	\$ 1,709.00	PSSE	6.6	P300LB1-48Z	\$ 6,560.00	PSSE	6.6
OXS5X85	\$ 4.00	H6	17.16	P18L1-48	\$ 1,095.00	PSSE	6.5	P300LB1-60Z	\$ 8,360.00	PSSE	6.6
OZXA-24	\$ 24.00	H6	17.96	P18L1-60	\$ 1,219.00	PSSE	6.5	P300LF1-48E	\$ 6,560.00	PSSE	6.6
OZXA-25	\$ 80.00	H6	17.96	P18L2-48M	\$ 1,395.00	PSSE	6.5	P300LF1-60E	\$ 8,360.00	PSSE	6.6
OZXA-26	\$ 190.00	H6	17.96	P18L2-60M	\$ 1,519.00	PSSE	6.5	P30D1-48	\$ 1,155.00	PSSE	6.5
P105D1-48	\$ 2,600.00	PSSE	6.5	P18LB1-48E	\$ 1,370.00	PSSE	6.6	P30D1-60	\$ 1,295.00	PSSE	6.5
P105D1-60	\$ 2,940.00	PSSE	6.5	P18LB1-60E	\$ 1,709.00	PSSE	6.6	P30D2-48M	\$ 1,480.00	PSSE	6.5
P105D2-48M	\$ 3,375.00	PSSE	6.5	P18LF1-48A	\$ 1,370.00	PSSE	6.6	P30D2-60M	\$ 1,620.00	PSSE	6.5
P105D2-60M	\$ 3,715.00	PSSE	6.5	P18LF1-60A	\$ 1,709.00	PSSE	6.6	P30DB1-48L	\$ 1,580.00	PSSE	6.6
P105DB1-48Y	\$ 3,600.00	PSSE	6.6	P22D1-48	\$ 1,155.00	PSSE	6.5	P30DB1-60N	\$ 1,835.00	PSSE	6.6
P105DB1-60X	\$ 4,195.00	PSSE	6.6	P22D1-60	\$ 1,295.00	PSSE	6.5	P30DF1-48C	\$ 1,580.00	PSSE	6.6
P105DF1-48E	\$ 3,600.00	PSSE	6.6	P22D2-48M	\$ 1,480.00	PSSE	6.5	P30DF1-60C	\$ 1,835.00	PSSE	6.6
P105DF1-60E	\$ 4,195.00	PSSE	6.6	P22D2-60M	\$ 1,620.00	PSSE	6.5	P30L1-48	\$ 1,155.00	PSSE	6.5
P105L1-48	\$ 2,600.00	PSSE	6.5	P22DB1-48K	\$ 1,580.00	PSSE	6.6	P30L1-60	\$ 1,295.00	PSSE	6.5

P30L2-48M – PR111/P-A-LI

Alphanumeric

0

Catalog number	List price	Discount schedule	Page number	Catalog number	List price	Discount schedule	Page number	Catalog number	List price	Discount schedule	Page number
P30L2-48M	\$ 1,480.00	PSSE	6.5	P50DF1-60D	\$ 2,565.00	PSSE	6.6	PDM11-FBP.050	\$ 45.70	I/O	6.34
P30L2-60M	\$ 1,620.00	PSSE	6.5	P50L1-48	\$ 1,595.00	PSSE	6.5	PDP21-FBP.025	\$ 390.39	I/O	6.34
P30LB1-48J	\$ 1,580.00	PSSE	6.6	P50L1-60	\$ 1,820.00	PSSE	6.5	PDR11-FBP.120	-	I/O	6.34
P30LB1-60J	\$ 1,835.00	PSSE	6.6	P50L2-48M	\$ 2,045.00	PSSE	6.5	PDX11-FBP.100	\$ 64.75	I/O	6.34
P30LF1-48B	\$ 1,580.00	PSSE	6.6	P50L2-60M	\$ 2,270.00	PSSE	6.5	PDX11-FBP.300	\$ 99.03	I/O	6.34
P30LF1-60B	\$ 1,835.00	PSSE	6.6	P50LB1-48N	\$ 2,195.00	PSSE	6.6	PDX11-FBP.500	\$ 133.30	I/O	6.34
P37D1-48	\$ 1,325.00	PSSE	6.5	P50LB1-60N	\$ 2,565.00	PSSE	6.6	PDX11-FBP.999	\$ 1,416.82	I/O	6.34
P37D1-60	\$ 1,475.00	PSSE	6.5	P50LF1-48C	\$ 2,195.00	PSSE	6.6	PEB-010-24	\$ 755.00	SSP	6.57
P37D2-48M	\$ 1,725.00	PSSE	6.5	P50LF1-60C	\$ 2,565.00	PSSE	6.6	PEB-010-48	\$ 755.00	SSP	6.57
P37D2-60M	\$ 1,875.00	PSSE	6.5	P60D1-48	\$ 1,860.00	PSSE	6.5	PEB-010-48-1	\$ 805.00	SSPE	6.58
P37DB1-48N	\$ 1,750.00	PSSE	6.6	P60D1-60	\$ 2,135.00	PSSE	6.5	PEB-010-60	\$ 755.00	SSP	6.57
P37DB1-60N	\$ 2,440.00	PSSE	6.6	P60D2-48M	\$ 2,360.00	PSSE	6.5	PEB-010-60-1	\$ 805.00	SSPE	6.58
P37DF1-48C	\$ 1,750.00	PSSE	6.6	P60D2-60M	\$ 2,635.00	PSSE	6.5	PEB-024-24	\$ 1,070.00	SSP	6.57
P37DF1-60C	\$ 2,040.00	PSSE	6.6	P60DB1-48T	\$ 2,460.00	PSSE	6.6	PEB-024-48	\$ 1,070.00	SSP	6.57
P37L1-48	\$ 1,325.00	PSSE	6.5	P60DB1-60S	\$ 2,905.00	PSSE	6.6	PEB-024-48-1	\$ 1,120.00	SSPE	6.58
P37L1-60	\$ 1,475.00	PSSE	6.5	P60DF1-48D	\$ 2,460.00	PSSE	6.6	PEB-024-60	\$ 1,070.00	SSP	6.57
P37L2-48M	\$ 1,725.00	PSSE	6.5	P60DF1-60D	\$ 2,905.00	PSSE	6.6	PEB-024-60-1	\$ 1,120.00	SSPE	6.58
P37L2-60M	\$ 1,875.00	PSSE	6.5	P60L1-48	\$ 1,860.00	PSSE	6.5	PEB-050-24	\$ 1,450.00	SSP	6.57
P37LB1-48K	\$ 1,750.00	PSSE	6.6	P60L1-60	\$ 2,135.00	PSSE	6.5	PEB-050-48	\$ 1,450.00	SSP	6.57
P37LB1-60K	\$ 2,040.00	PSSE	6.6	P60L2-48M	\$ 2,360.00	PSSE	6.5	PEB-050-48-1	\$ 1,650.00	SSPE	6.58
P37LF1-48B	\$ 1,750.00	PSSE	6.6	P60L2-60M	\$ 2,635.00	PSSE	6.5	PEB-050-60	\$ 1,450.00	SSP	6.57
P37LF1-60B	\$ 2,040.00	PSSE	6.6	P60LB1-48N	\$ 2,460.00	PSSE	6.6	PEB-050-60-1	\$ 1,650.00	SSPE	6.58
P44D1-48	\$ 1,475.00	PSSE	6.5	P60LB1-60N	\$ 2,905.00	PSSE	6.6	PEB-100-24	\$ 2,250.00	SSP	6.57
P44D1-60	\$ 1,755.00	PSSE	6.5	P60LF1-48C	\$ 2,460.00	PSSE	6.6	PEB-100-48	\$ 2,250.00	SSP	6.57
P44D2-48M	\$ 1,925.00	PSSE	6.5	P60LF1-60C	\$ 2,905.00	PSSE	6.6	PEB-100-48-1	\$ 2,450.00	SSPE	6.58
P44D2-60M	\$ 2,205.00	PSSE	6.5	P72D1-48	\$ 1,935.00	PSSE	6.5	PEB-100-60	\$ 2,250.00	SSP	6.57
P44DB1-48R	\$ 2,075.00	PSSE	6.6	P72D1-60	\$ 2,225.00	PSSE	6.5	PEB-100-60-1	\$ 2,450.00	SSPE	6.58
P44DB1-60R	\$ 2,400.00	PSSE	6.6	P72D2-48M	\$ 2,485.00	PSSE	6.5	PEB-1000-24	\$ 13,000.00	SSP	6.57
P44DF1-48C	\$ 2,075.00	PSSE	6.6	P72D2-60M	\$ 2,775.00	PSSE	6.5	PEB-1000-48	\$ 13,000.00	SSP	6.57
P44DF1-60C	\$ 2,400.00	PSSE	6.6	P72DB1-48T	\$ 2,535.00	PSSE	6.6	PEB-1000-48-1	\$ 13,500.00	SSPE	6.58
P44L1-48	\$ 1,475.00	PSSE	6.5	P72DB1-60T	\$ 3,010.00	PSSE	6.6	PEB-1000-60	\$ 13,000.00	SSP	6.57
P44L1-60	\$ 1,755.00	PSSE	6.5	P72DF1-48D	\$ 2,535.00	PSSE	6.6	PEB-1000-60-1	\$ 13,500.00	SSPE	6.58
P44L2-48M	\$ 1,925.00	PSSE	6.5	P72DF1-60D	\$ 3,010.00	PSSE	6.6	PEB-200-24	\$ 3,900.00	SSP	6.57
P44L2-60M	\$ 2,205.00	PSSE	6.5	P72L1-48	\$ 1,935.00	PSSE	6.5	PEB-200-48	\$ 3,900.00	SSP	6.57
P44LB1-48L	\$ 2,075.00	PSSE	6.6	P72L1-60	\$ 2,225.00	PSSE	6.5	PEB-200-48-1	\$ 4,320.00	SSPE	6.58
P44LB1-60L	\$ 2,400.00	PSSE	6.6	P72L2-48M	\$ 2,485.00	PSSE	6.5	PEB-200-60	\$ 3,900.00	SSP	6.57
P44LF1-48C	\$ 2,075.00	PSSE	6.6	P72L2-60M	\$ 2,775.00	PSSE	6.5	PEB-200-60-1	\$ 4,320.00	SSPE	6.58
P44LF1-60B	\$ 2,400.00	PSSE	6.6	P72LB1-48R	\$ 2,535.00	PSSE	6.6	PEB-300-24	\$ 4,300.00	SSP	6.57
P44R1.5	\$ 193.00	F1	19.15	P72LB1-60R	\$ 3,010.00	PSSE	6.6	PEB-300-48	\$ 4,300.00	SSP	6.57
P44R10	\$ 257.00	F1	19.15	P72LF1-48C	\$ 2,535.00	PSSE	6.6	PEB-300-48-1	\$ 4,800.00	SSPE	6.58
P44R15	\$ 289.00	F1	19.15	P72LF1-60C	\$ 3,010.00	PSSE	6.6	PEB-300-60	\$ 4,300.00	SSP	6.57
P44R2	\$ 198.00	F1	19.15	P82D2-60M	\$ 3,580.00	PSSE	6.5	PEB-300-60-1	\$ 4,800.00	SSPE	6.58
P44R20	\$ 370.00	F1	19.15	P85D1-48	\$ 2,475.00	PSSE	6.5	PEB-400-24	\$ 6,500.00	SSP	6.57
P44R21	\$ 380.00	F1	19.15	P85D1-60	\$ 2,805.00	PSSE	6.5	PEB-400-48	\$ 6,500.00	SSP	6.57
P44R22.5	\$ 402.00	F1	19.15	P85D2-48M	\$ 3,250.00	PSSE	6.5	PEB-400-48-1	\$ 7,000.00	SSPE	6.58
P44R25	\$ 423.00	F1	19.15	P85DB1-48V	\$ 3,475.00	PSSE	6.6	PEB-400-60	\$ 6,500.00	SSP	6.57
P44R27	\$ 445.00	F1	19.15	P85DB1-60X	\$ 4,060.00	PSSE	6.6	PEB-400-60-1	\$ 7,000.00	SSPE	6.58
P44R3	\$ 209.00	F1	19.15	P85DF1-48D	\$ 3,485.00	PSSE	6.6	PEB-550-24	\$ 8,700.00	SSP	6.57
P44R30	\$ 477.00	F1	19.15	P85DF1-60E	\$ 4,060.00	PSSE	6.6	PEB-550-48	\$ 8,700.00	SSP	6.57
P44R4	\$ 220.00	F1	19.15	P85L1-48	\$ 2,475.00	PSSE	6.5	PEB-550-48-1	\$ 9,200.00	SSPE	6.58
P44R5	\$ 231.00	F1	19.15	P85L1-60	\$ 2,805.00	PSSE	6.5	PEB-550-60	\$ 8,700.00	SSP	6.57
P44R6	\$ 241.00	F1	19.15	P85L2-48M	\$ 3,250.00	PSSE	6.5	PEB-550-60-1	\$ 9,200.00	SSPE	6.58
P44R7.5	\$ 247.00	F1	19.15	P85L2-60M	\$ 3,580.00	PSSE	6.5	PEB-800-24	\$ 10,250.00	SSP	6.57
P50D1-48	\$ 1,595.00	PSSE	6.5	P85LB1-48S	\$ 3,475.00	PSSE	6.6	PEB-800-48	\$ 10,250.00	SSP	6.57
P50D1-60	\$ 1,820.00	PSSE	6.5	P85LB1-60S	\$ 4,060.00	PSSE	6.6	PEB-800-48-1	\$ 10,750.00	SSPE	6.58
P50D2-48M	\$ 2,045.00	PSSE	6.5	P85LF1-48D	\$ 3,475.00	PSSE	6.6	PEB-800-60	\$ 10,250.00	SSP	6.57
P50D2-60M	\$ 2,270.00	PSSE	6.5	P85LF1-60D	\$ 4,060.00	PSSE	6.6	PEB-800-60-1	\$ 10,750.00	SSPE	6.58
P50DB1-48S	\$ 2,195.00	PSSE	6.6	PDF11-FBP.0	\$ 38.09	I/O	6.34	PG16-1/2NPT	\$ 10.00	MA	5.4
P50DB1-60S	\$ 2,565.00	PSSE	6.6	PDF11-FBP.050	\$ 45.70	I/O	6.34	PR010/T	\$ 12,500.00	EX	16.31
P50DF1-48D	\$ 2,195.00	PSSE	6.6	PDM11-FBP.0	\$ 38.09	I/O	6.34	PR111/P-A-LI	\$ 1,089.00	EX	16.26

PR111/P-A-LSI – S2-BM6

Catalog number	List price	Discount schedule	Page number	Catalog number	List price	Discount schedule	Page number	Catalog number	List price	Discount schedule	Page number
PR111/P-A-LSI	\$ 1,604.00	EX	16.26	PSCT-60	\$ 70.00	PSS	6.8	PSTB470-600-70	\$ 7,000.00	PST	6.25
PR111/P-A-LSIG	\$ 2,297.00	EX	16.26	PSCT-75	\$ 130.00	PSS	6.8	PSTB570-600-70	\$ 8,550.00	PST	6.25
PR111/P-LI	\$ 1,089.00	EX	16.26	PSLK-185	\$ 150.00	PSS	6.31	PSTB720-600-70	\$ 9,630.00	PST	6.25
PR111/P-LSI	\$ 1,604.00	EX	16.26	PSLK-300	\$ 195.00	PSS	6.31	PSTB840-600-70	\$ 10,900.00	PST	6.25
PR111/P-LSIG	\$ 2,297.00	EX	16.26	PSLK-300/2	\$ 280.00	PSS	6.31	RA5	\$ 75.00	ABA	1.23
PR112/P-A-LSI	\$ 3,299.00	EX	16.26	PSLK-580/2	\$ 350.00	PSS	6.31	RC-EH250/415	\$ 26.00	ABA	1.21
PR112/P-A-LSIG	\$ 3,993.00	EX	16.26	PSLK-750/3	\$ 525.00	PSS	6.31	RC-EH250/48	\$ 26.00	ABA	1.21
PR112/P-LSI	\$ 3,299.00	EX	16.26	PSLW-44	\$ 65.00	PSS	6.8	RC-EH800/110	\$ 26.00	ABA	1.21
PR112/P-LSIG	\$ 3,993.00	EX	16.26	PSLW-72	\$ 70.00	PSS	6.8	RC-EH800/600	\$ 26.00	ABA	1.21
PR112/PD-A-LSI	\$ 7,979.00	EX	16.26	PSS03-220B	\$ 270.00	PSS	6.3	RC325-110V	\$ 165.00	MA	5.11
PR112/PD-A-LSIG	\$ 8,672.00	EX	16.26	PSS03-400B	\$ 270.00	PSS	6.3	RC325-230V	\$ 165.00	MA	5.11
PR112/PD-LSI	\$ 7,979.00	EX	16.26	PSS03-480B	\$ 270.00	PSS	6.3	RC325-24V	\$ 165.00	MA	5.11
PR112/PD-LSIG	\$ 8,672.00	EX	16.26	PSS105/181-500F	\$ 1,700.00	PSS	6.4	RC325-48V	\$ 165.00	MA	5.11
PR113/P-A-LSIG	\$ 8,412.00	EX	16.26	PSS105/181-690F	\$ 2,040.00	PSS	6.4	RC325-60V	\$ 165.00	MA	5.11
PR113/P-LSIG	\$ 8,412.00	EX	16.26	PSS12-220B	\$ 345.00	PSS	6.3	RC5-1/133	\$ 30.00	ABA	1.21
PR113/PD-A-LSIG	\$ 13,091.00	EX	16.26	PSS12-400B	\$ 345.00	PSS	6.3	RC5-1/250	\$ 30.00	ABA	1.21
PR113/PD-LSIG	\$ 13,091.00	EX	16.26	PSS12-480B	\$ 345.00	PSS	6.3	RC5-1/440	\$ 30.00	ABA	1.21
PR120/B	\$ 275.00	EX	16.31	PSS12-600B	\$ 375.00	PSS	6.3	RC5-1/50	\$ 30.00	ABA	1.21
PS1-2-0	\$ 24.00	MA	5.5	PSS142/245-500F	\$ 2,250.00	PSS	6.4	RC5-2/133	\$ 30.00	ABA	1.21
PS1-2-1	\$ 24.00	MA	5.5	PSS142/245-690F	\$ 2,700.00	PSS	6.4	RC5-2/250	\$ 30.00	ABA	1.21
PS1-2-2	\$ 24.00	MA	5.5	PSS175/300-500F	\$ 2,900.00	PSS	6.4	RC5-2/440	\$ 30.00	ABA	1.21
PS1-3-0	\$ 30.00	MA	5.5	PSS175/300-690F	\$ 3,395.00	PSS	6.4	RC5-2/50	\$ 30.00	ABA	1.21
PS1-3-1	\$ 30.00	MA	5.5	PSS18/30-500F	\$ 620.00	PSS	6.4	RFL1	\$ 12.00	RA	10.122
PS1-3-2	\$ 30.00	MA	5.5	PSS18/30-690F	\$ 744.00	PSS	6.4	RT/264	\$ 30.00	ABA	1.123
PS1-4-0	\$ 36.00	MA	5.5	PSS25-220B	\$ 405.00	PSS	6.3	RT5/150	\$ 30.00	ABA	1.123
PS1-4-1	\$ 36.00	MA	5.5	PSS25-400B	\$ 405.00	PSS	6.3	RT5/264	\$ 30.00	ABA	1.21
PS1-4-2	\$ 36.00	MA	5.5	PSS25-480B	\$ 405.00	PSS	6.3	RT5/32	\$ 30.00	ABA	1.123
PS1-5-0	\$ 42.00	MA	5.5	PSS25-600B	\$ 445.00	PSS	6.3	RT5/65	\$ 30.00	ABA	1.123
PS1-5-1	\$ 42.00	MA	5.5	PSS250/430-500F	\$ 3,400.00	PSS	6.4	RT5/90	\$ 30.00	ABA	1.123
PS1-5-2	\$ 42.00	MA	5.5	PSS250/430-690F	\$ 3,965.00	PSS	6.4	RV-BC6/250	\$ 24.00	AA	4.12
PS3-2-0	\$ 24.00	MA	5.12	PSS30/52-500F	\$ 680.00	PSS	6.4	RV-BC6/380	\$ 24.00	AA	4.12
PS3-2-1	\$ 30.00	MA	5.12	PSS30/52-690F	\$ 820.00	PSS	6.4	RV-BC6/60	\$ 24.00	AA	4.12
PS3-2-2	\$ 30.00	MA	5.12	PSS300/515-500F	\$ 3,950.00	PSS	6.4	RV5/133	\$ 30.00	ABA	1.21
PS3-3-0	\$ 30.00	MA	5.12	PSS300/515-690F	\$ 4,530.00	PSS	6.4	RV5/250	\$ 30.00	ABA	1.21
PS3-3-1	\$ 34.50	MA	5.12	PSS37/64-500F	\$ 750.00	PSS	6.4	RV5/440	\$ 30.00	ABA	1.21
PS3-4-0	\$ 33.00	MA	5.12	PSS37/64-690F	\$ 900.00	PSS	6.4	RV5/50	\$ 30.00	ABA	1.21
PS3-4-1	\$ 37.50	MA	5.12	PSS44/76-500F	\$ 900.00	PSS	6.4	S1-M1	\$ 24.00	MA	5.5
PS3-4-2	\$ 37.50	MA	5.12	PSS44/76-690F	\$ 1,080.00	PSS	6.4	S1-M2	\$ 24.00	MA	5.5
PS3-5-0	\$ 39.00	MA	5.12	PSS50/85-500F	\$ 1,120.00	PSS	6.4	S1E-1	\$ 200.00	SE	15.66
PS3-5-1	\$ 42.00	MA	5.12	PSS50/85-690F	\$ 1,345.00	PSS	6.4	S1E-3R12	\$ 305.00	SE	15.66
PS4-2-0	\$ 51.00	MA	5.17	PSS60/105-500F	\$ 1,325.00	PSS	6.4	S1F5M18WC1PO	\$ 110.00	RP	10.75
PS4-2-2	\$ 58.50	MA	5.17	PSS60/105-690F	\$ 1,590.00	PSS	6.4	S1N015TL	\$ 392.00	S1	15.30
PS4-3-0	\$ 60.00	MA	5.17	PSS72/124-500F	\$ 1,460.00	PSS	6.4	S1N020TL	\$ 392.00	S1	15.30
PS4-3-2	\$ 60.00	MA	5.17	PSS72/124-690F	\$ 1,750.00	PSS	6.4	S1N025TL	\$ 392.00	S1	15.30
PS4-4-0	\$ 76.50	MA	5.17	PSS85/147-500F	\$ 1,650.00	PSS	6.4	S1N030TL	\$ 392.00	S1	15.30
PS4-4-2	\$ 84.00	MA	5.17	PSS85/147-690F	\$ 1,980.00	PSS	6.4	S1N040TL	\$ 392.00	S1	15.30
PSB-3UL	\$ 60.00	CB8	14.15	PST105-600-70	\$ 2,410.00	PST	6.25	S1N050TL	\$ 392.00	S1	15.30
PSB-53UL	\$ 40.00	CB8	14.15	PST142-600-70	\$ 3,375.00	PST	6.25	S1N060TL	\$ 392.00	S1	15.30
PSB-END3	\$ 2.00	CB8	14.17	PST175-600-70	\$ 3,420.00	PST	6.25	S1N070TL	\$ 459.00	S1	15.30
PSB-END4	\$ 2.00	CB8	14.17	PST210-600-70	\$ 3,870.00	PST	6.25	S1N080TL	\$ 459.00	S1	15.30
PSB-END5	\$ 2.00	CB8	14.17	PST250-600-70	\$ 4,350.00	PST	6.25	S1N090TL	\$ 459.00	S1	15.30
PSB-END6	\$ 2.00	CB8	14.17	PST300-600-70	\$ 1,330.00	PST	6.25	S1N100TL	\$ 459.00	S1	15.30
PSCT-100	\$ 130.00	PSS	6.8	PST300-600-70	\$ 4,480.00	PST	6.25	S2-A1	\$ 138.00	CB8	14.18
PSCT-125	\$ 130.00	PSS	6.8	PST37-600-70	\$ 1,360.00	PST	6.25	S2-A2	\$ 138.00	CB8	14.18
PSCT-150	\$ 130.00	PSS	6.8	PST44-600-70	\$ 1,390.00	PST	6.25	S2-BM1	\$ 216.00	CB8	14.18
PSCT-200	\$ 130.00	PSS	6.8	PST50-600-70	\$ 1,730.00	PST	6.25	S2-BM2	\$ 216.00	CB8	14.18
PSCT-250	\$ 130.00	PSS	6.8	PST72-600-70	\$ 1,755.00	PST	6.25	S2-BM3	\$ 216.00	CB8	14.18
PSCT-40	\$ 70.00	PSS	6.8	PST85-600-70	\$ 2,380.00	PST	6.25	S2-BM4	\$ 216.00	CB8	14.18
PSCT-400	\$ 130.00	PSS	6.8	PSTB1050-600-70	\$ 18,000.00	PST	6.25	S2-BM5	\$ 216.00	CB8	14.18
PSCT-50	\$ 70.00	PSS	6.8	PSTB370-600-70	\$ 5,660.00	PST	6.25	S2-BM6	\$ 216.00	CB8	14.18

S2-H02 – S263-CO.5NA

Alphanumeric

0

Catalog number	List price	Discount schedule	Page number	Catalog number	List price	Discount schedule	Page number	Catalog number	List price	Discount schedule	Page number
S2-H02	\$ 36.00	CB8	14.18	S261-C6NA	\$ 84.00	CB5	14.7	S262-D40	\$ 116.00	CB5	14.8
S2-H11	\$ 36.00	CB8	14.18	S261-C8	\$ 42.00	CB5	14.7	S262-D50	\$ 136.00	CB5	14.8
S2-H12	\$ 54.00	CB8	14.18	S261-C8NA	\$ 84.00	CB5	14.7	S262-D6	\$ 96.00	CB5	14.8
S2-H20	\$ 36.00	CB8	14.18	S261-CO.5	\$ 42.00	CB5	14.7	S262-D63	\$ 152.00	CB5	14.8
S2-H21	\$ 54.00	CB8	14.18	S261-CO.5NA	\$ 84.00	CB5	14.7	S262-D8	\$ 96.00	CB5	14.8
S2-H21KL	\$ 60.00	CB8	14.18	S261-D1	\$ 42.00	CB5	14.8	S262-DO.5	\$ 96.00	CB5	14.8
S2-NT	\$ 27.00	CB8	14.18	S261-D1.6	\$ 42.00	CB5	14.8	S263-B10	\$ 118.00	CB5B	14.6
S2-S	\$ 48.00	CB8	14.18	S261-D10	\$ 42.00	CB5	14.8	S263-B10NA	\$ 142.00	CB5B	14.6
S2-S/H	\$ 58.00	CB8	14.18	S261-D13	\$ 42.00	CB5	14.8	S263-B13	\$ 118.00	CB5B	14.6
S2-SCR	-	CB7	14.11	S261-D16	\$ 42.00	CB5	14.8	S263-B13NA	\$ 142.00	CB5B	14.6
S22-KS15	\$ 96.00	CB5	14.9	S261-D2	\$ 42.00	CB5	14.8	S263-B16	\$ 118.00	CB5B	14.6
S261-B10	\$ 36.00	CB5B	14.6	S261-D20	\$ 42.00	CB5	14.8	S263-B16NA	\$ 142.00	CB5B	14.6
S261-B10NA	\$ 62.00	CB5B	14.6	S261-D25	\$ 46.00	CB5	14.8	S263-B20	\$ 130.00	CB5B	14.6
S261-B13	\$ 36.00	CB5B	14.6	S261-D3	\$ 42.00	CB5	14.8	S263-B20NA	\$ 162.00	CB5B	14.6
S261-B13NA	\$ 62.00	CB5B	14.6	S261-D32	\$ 48.00	CB5	14.8	S263-B25	\$ 132.00	CB5B	14.6
S261-B16	\$ 36.00	CB5B	14.6	S261-D4	\$ 42.00	CB5	14.8	S263-B25NA	\$ 168.00	CB5B	14.6
S261-B16NA	\$ 62.00	CB5B	14.6	S261-D40	\$ 52.00	CB5	14.8	S263-B32	\$ 142.00	CB5B	14.6
S261-B20	\$ 38.00	CB5B	14.6	S261-D50	\$ 60.00	CB5	14.8	S263-B32NA	\$ 176.00	CB5B	14.6
S261-B20NA	\$ 68.00	CB5B	14.6	S261-D6	\$ 42.00	CB5	14.8	S263-B40	\$ 148.00	CB5B	14.6
S261-B25	\$ 38.00	CB5B	14.6	S261-D63	\$ 68.00	CB5	14.8	S263-B40NA	\$ 184.00	CB5B	14.6
S261-B25NA	\$ 72.00	CB5B	14.6	S261-D8	\$ 42.00	CB5	14.8	S263-B50	\$ 170.00	CB5B	14.6
S261-B32	\$ 40.00	CB5B	14.6	S261-DO.5	\$ 42.00	CB5	14.8	S263-B50NA	\$ 212.00	CB5B	14.6
S261-B32NA	\$ 74.00	CB5B	14.6	S262-B10	\$ 78.00	CB5B	14.6	S263-B6	\$ 118.00	CB5B	14.6
S261-B40	\$ 42.00	CB5B	14.6	S262-B13	\$ 78.00	CB5B	14.6	S263-B63	\$ 194.00	CB5B	14.6
S261-B40NA	\$ 76.00	CB5B	14.6	S262-B16	\$ 78.00	CB5B	14.6	S263-B63NA	\$ 240.00	CB5B	14.6
S261-B50	\$ 48.00	CB5B	14.6	S262-B20	\$ 86.00	CB5B	14.6	S263-B6NA	\$ 142.00	CB5B	14.6
S261-B50NA	\$ 90.00	CB5B	14.6	S262-B25	\$ 88.00	CB5B	14.6	S263-C1	\$ 138.00	CB5	14.7
S261-B6	\$ 36.00	CB5B	14.6	S262-B32	\$ 94.00	CB5B	14.6	S263-C1.6	\$ 138.00	CB5	14.7
S261-B63	\$ 56.00	CB5B	14.6	S262-B40	\$ 98.00	CB5B	14.6	S263-C1.6NA	\$ 200.00	CB5	14.7
S261-B63NA	\$ 102.00	CB5B	14.6	S262-B50	\$ 112.00	CB5B	14.6	S263-C10	\$ 138.00	CB5	14.7
S261-B6NA	\$ 62.00	CB5B	14.6	S262-B6	\$ 78.00	CB5B	14.6	S263-C10NA	\$ 200.00	CB5	14.7
S261-C1	\$ 42.00	CB5	14.7	S262-B63	\$ 128.00	CB5B	14.6	S263-C13	\$ 138.00	CB5	14.7
S261-C1.6	\$ 42.00	CB5	14.7	S262-C1	\$ 96.00	CB5	14.7	S263-C13NA	\$ 200.00	CB5	14.7
S261-C1.6NA	\$ 84.00	CB5	14.7	S262-C1.6	\$ 96.00	CB5	14.7	S263-C16	\$ 138.00	CB5	14.7
S261-C10	\$ 42.00	CB5	14.7	S262-C10	\$ 96.00	CB5	14.7	S263-C16NA	\$ 200.00	CB5	14.7
S261-C10NA	\$ 84.00	CB5	14.7	S262-C13	\$ 96.00	CB5	14.7	S263-C1NA	\$ 200.00	CB5	14.7
S261-C13	\$ 42.00	CB5	14.7	S262-C16	\$ 96.00	CB5	14.7	S263-C2	\$ 138.00	CB5	14.7
S261-C13NA	\$ 84.00	CB5	14.7	S262-C2	\$ 96.00	CB5	14.7	S263-C20	\$ 138.00	CB5	14.7
S261-C16	\$ 42.00	CB5	14.7	S262-C20	\$ 96.00	CB5	14.7	S263-C20NA	\$ 200.00	CB5	14.7
S261-C16NA	\$ 84.00	CB5	14.7	S262-C25	\$ 106.00	CB5	14.7	S263-C25	\$ 156.00	CB5	14.7
S261-C1NA	\$ 84.00	CB5	14.7	S262-C3	\$ 96.00	CB5	14.7	S263-C25NA	\$ 206.00	CB5	14.7
S261-C2	\$ 42.00	CB5	14.7	S262-C32	\$ 106.00	CB5	14.7	S263-C2NA	\$ 200.00	CB5	14.7
S261-C20	\$ 42.00	CB5	14.7	S262-C4	\$ 96.00	CB5	14.7	S263-C3	\$ 138.00	CB5	14.7
S261-C20NA	\$ 84.00	CB5	14.7	S262-C40	\$ 116.00	CB5	14.7	S263-C32	\$ 158.00	CB5	14.7
S261-C25	\$ 46.00	CB5	14.7	S262-C50	\$ 136.00	CB5	14.7	S263-C32NA	\$ 212.00	CB5	14.7
S261-C25NA	\$ 88.00	CB5	14.7	S262-C6	\$ 96.00	CB5	14.7	S263-C3NA	\$ 200.00	CB5	14.7
S261-C2NA	\$ 84.00	CB5	14.7	S262-C63	\$ 152.00	CB5	14.7	S263-C4	\$ 138.00	CB5	14.7
S261-C3	\$ 42.00	CB5	14.7	S262-C8	\$ 96.00	CB5	14.7	S263-C40	\$ 174.00	CB5	14.7
S261-C32	\$ 48.00	CB5	14.7	S262-CO.5	\$ 96.00	CB5	14.7	S263-C40NA	\$ 224.00	CB5	14.7
S261-C32NA	\$ 90.00	CB5	14.7	S262-D1	\$ 96.00	CB5	14.8	S263-C4NA	\$ 200.00	CB5	14.7
S261-C3NA	\$ 84.00	CB5	14.7	S262-D1.6	\$ 96.00	CB5	14.8	S263-C50	\$ 200.00	CB5	14.7
S261-C4	\$ 42.00	CB5	14.7	S262-D10	\$ 96.00	CB5	14.8	S263-C50NA	\$ 264.00	CB5	14.7
S261-C40	\$ 52.00	CB5	14.7	S262-D13	\$ 96.00	CB5	14.8	S263-C6	\$ 138.00	CB5	14.7
S261-C40NA	\$ 96.00	CB5	14.7	S262-D16	\$ 96.00	CB5	14.8	S263-C63	\$ 228.00	CB5	14.7
S261-C4NA	\$ 84.00	CB5	14.7	S262-D2	\$ 96.00	CB5	14.8	S263-C63NA	\$ 304.00	CB5	14.7
S261-C50	\$ 60.00	CB5	14.7	S262-D20	\$ 96.00	CB5	14.8	S263-C6NA	\$ 200.00	CB5	14.7
S261-C50NA	\$ 112.00	CB5	14.7	S262-D25	\$ 106.00	CB5	14.8	S263-C8	\$ 138.00	CB5	14.7
S261-C6	\$ 42.00	CB5	14.7	S262-D3	\$ 96.00	CB5	14.8	S263-C8NA	\$ 200.00	CB5	14.7
S261-C63	\$ 68.00	CB5	14.7	S262-D32	\$ 106.00	CB5	14.8	S263-CO.5	\$ 138.00	CB5	14.7
S261-C63NA	\$ 130.00	CB5	14.7	S262-D4	\$ 96.00	CB5	14.8	S263-CO.5NA	\$ 200.00	CB5	14.7

S263-D1 – S281-K40W

Catalog number	List price	Discount schedule	Page number	Catalog number	List price	Discount schedule	Page number	Catalog number	List price	Discount schedule	Page number
S263-D1	\$ 138.00	CB5	14.8	S271-K3	\$ 42.00	CB5	14.9	S273-K32NA	\$ 212.00	CB5	14.9
S263-D1.6	\$ 138.00	CB5	14.8	S271-K32	\$ 48.00	CB5	14.9	S273-K3NA	\$ 200.00	CB5	14.9
S263-D10	\$ 138.00	CB5	14.8	S271-K32NA	\$ 90.00	CB5	14.9	S273-K4	\$ 138.00	CB5	14.9
S263-D13	\$ 138.00	CB5	14.8	S271-K3NA	\$ 84.00	CB5	14.9	S273-K40	\$ 174.00	CB5	14.9
S263-D16	\$ 138.00	CB5	14.8	S271-K4	\$ 42.00	CB5	14.9	S273-K40NA	\$ 224.00	CB5	14.9
S263-D2	\$ 138.00	CB5	14.8	S271-K40	\$ 52.00	CB5	14.9	S273-K4NA	\$ 200.00	CB5	14.9
S263-D20	\$ 138.00	CB5	14.8	S271-K40NA	\$ 96.00	CB5	14.9	S273-K50	\$ 200.00	CB5	14.9
S263-D25	\$ 156.00	CB5	14.8	S271-K4NA	\$ 84.00	CB5	14.9	S273-K50NA	\$ 264.00	CB5	14.9
S263-D3	\$ 138.00	CB5	14.8	S271-K50	\$ 60.00	CB5	14.9	S273-K6	\$ 138.00	CB5	14.9
S263-D32	\$ 158.00	CB5	14.8	S271-K50NA	\$ 112.00	CB5	14.9	S273-K63	\$ 228.00	CB5	14.9
S263-D4	\$ 138.00	CB5	14.8	S271-K6	\$ 42.00	CB5	14.9	S273-K63NA	\$ 304.00	CB5	14.9
S263-D40	\$ 174.00	CB5	14.8	S271-K63	\$ 68.00	CB5	14.9	S273-K6NA	\$ 200.00	CB5	14.9
S263-D50	\$ 200.00	CB5	14.8	S271-K63NA	\$ 130.00	CB5	14.9	S273-K8	\$ 138.00	CB5	14.9
S263-D6	\$ 138.00	CB5	14.8	S271-K6NA	\$ 84.00	CB5	14.9	S273-K8NA	\$ 200.00	CB5	14.9
S263-D63	\$ 228.00	CB5	14.8	S271-K8	\$ 42.00	CB5	14.9	S273-KO.5	\$ 138.00	CB5	14.9
S263-D8	\$ 138.00	CB5	14.8	S271-K8NA	\$ 84.00	CB5	14.9	S273-KO.5NA	\$ 200.00	CB5	14.9
S263-DO.5	\$ 138.00	CB5	14.8	S271-KO.5	\$ 42.00	CB5	14.9	S273-KS15	\$ 138.00	CB5	14.9
S264-B10	\$ 156.00	CB5B	14.6	S271-KO.5NA	\$ 84.00	CB5	14.9	S273-KS30	\$ 158.00	CB5	14.9
S264-B13	\$ 156.00	CB5B	14.6	S271-KS15	\$ 42.00	CB5	14.9	S273-KS5	\$ 138.00	CB5	14.9
S264-B16	\$ 156.00	CB5B	14.6	S271-KS30	\$ 48.00	CB5	14.9	S273-KS60	\$ 228.00	CB5	14.9
S264-B20	\$ 172.00	CB5B	14.6	S271-KS5	\$ 42.00	CB5	14.9	S274-K1	\$ 218.00	CB5	14.9
S264-B25	\$ 176.00	CB5B	14.6	S271-KS60	\$ 68.00	CB5	14.9	S274-K1.6	\$ 218.00	CB5	14.9
S264-B32	\$ 188.00	CB5B	14.6	S272-K1	\$ 96.00	CB5	14.9	S274-K10	\$ 218.00	CB5	14.9
S264-B40	\$ 196.00	CB5B	14.6	S272-K1.6	\$ 96.00	CB5	14.9	S274-K13	\$ 218.00	CB5	14.9
S264-B50	\$ 224.00	CB5B	14.6	S272-K10	\$ 96.00	CB5	14.9	S274-K16	\$ 218.00	CB5	14.9
S264-B6	\$ 156.00	CB5B	14.6	S272-K13	\$ 96.00	CB5	14.9	S274-K2	\$ 218.00	CB5	14.9
S264-B63	\$ 256.00	CB5B	14.6	S272-K16	\$ 96.00	CB5	14.9	S274-K20	\$ 218.00	CB5	14.9
S264-C1	\$ 218.00	CB5	14.7	S272-K2	\$ 96.00	CB5	14.9	S274-K25	\$ 234.00	CB5	14.9
S264-C1.6	\$ 218.00	CB5	14.7	S272-K20	\$ 96.00	CB5	14.9	S274-K3	\$ 218.00	CB5	14.9
S264-C10	\$ 218.00	CB5	14.7	S272-K25	\$ 106.00	CB5	14.9	S274-K32	\$ 238.00	CB5	14.9
S264-C13	\$ 218.00	CB5	14.7	S272-K3	\$ 96.00	CB5	14.9	S274-K4	\$ 218.00	CB5	14.9
S264-C16	\$ 218.00	CB5	14.7	S272-K32	\$ 106.00	CB5	14.9	S274-K40	\$ 260.00	CB5	14.9
S264-C2	\$ 218.00	CB5	14.7	S272-K4	\$ 96.00	CB5	14.9	S274-K50	\$ 300.00	CB5	14.9
S264-C20	\$ 218.00	CB5	14.7	S272-K40	\$ 116.00	CB5	14.9	S274-K6	\$ 218.00	CB5	14.9
S264-C25	\$ 234.00	CB5	14.7	S272-K50	\$ 136.00	CB5	14.9	S274-K63	\$ 338.00	CB5	14.9
S264-C3	\$ 218.00	CB5	14.7	S272-K6	\$ 96.00	CB5	14.9	S274-K8	\$ 218.00	CB5	14.9
S264-C32	\$ 238.00	CB5	14.7	S272-K63	\$ 152.00	CB5	14.9	S274-KO.5	\$ 218.00	CB5	14.9
S264-C4	\$ 218.00	CB5	14.7	S272-K8	\$ 96.00	CB5	14.9	S281-K1	\$ 54.00	CB7	14.10
S264-C40	\$ 260.00	CB5	14.7	S272-KO.5	\$ 96.00	CB5	14.9	S281-K1.6	\$ 54.00	CB7	14.10
S264-C50	\$ 300.00	CB5	14.7	S272-KS30	\$ 106.00	CB5	14.9	S281-K1.6W	\$ 54.00	CB7	14.11
S264-C6	\$ 218.00	CB5	14.7	S272-KS5	\$ 96.00	CB5	14.9	S281-K10	\$ 54.00	CB7	14.10
S264-C63	\$ 338.00	CB5	14.7	S272-KS60	\$ 152.00	CB5	14.9	S281-K10W	\$ 54.00	CB7	14.11
S264-C8	\$ 218.00	CB5	14.7	S273-K1	\$ 138.00	CB5	14.9	S281-K13	\$ 54.00	CB7	14.10
S264-CO.5	\$ 218.00	CB5	14.7	S273-K1.6	\$ 138.00	CB5	14.9	S281-K13W	\$ 54.00	CB7	14.11
S271-K1	\$ 42.00	CB5	14.9	S273-K1.6NA	\$ 200.00	CB5	14.9	S281-K16	\$ 54.00	CB7	14.10
S271-K1.6	\$ 42.00	CB5	14.9	S273-K10	\$ 138.00	CB5	14.9	S281-K16W	\$ 54.00	CB7	14.11
S271-K1.6NA	\$ 84.00	CB5	14.9	S273-K10NA	\$ 200.00	CB5	14.9	S281-K1W	\$ 54.00	CB7	14.11
S271-K10	\$ 42.00	CB5	14.9	S273-K13	\$ 138.00	CB5	14.9	S281-K2	\$ 54.00	CB7	14.10
S271-K10NA	\$ 84.00	CB5	14.9	S273-K13NA	\$ 200.00	CB5	14.9	S281-K20	\$ 54.00	CB7	14.10
S271-K13	\$ 42.00	CB5	14.9	S273-K16	\$ 138.00	CB5	14.9	S281-K20W	\$ 54.00	CB7	14.11
S271-K13NA	\$ 84.00	CB5	14.9	S273-K16NA	\$ 200.00	CB5	14.9	S281-K25	\$ 56.00	CB7	14.10
S271-K16	\$ 42.00	CB5	14.9	S273-K1NA	\$ 200.00	CB5	14.9	S281-K25W	\$ 56.00	CB7	14.11
S271-K16NA	\$ 84.00	CB5	14.9	S273-K2	\$ 138.00	CB5	14.9	S281-K2W	\$ 54.00	CB7	14.11
S271-K1NA	\$ 84.00	CB5	14.9	S273-K20	\$ 138.00	CB5	14.9	S281-K3	\$ 54.00	CB7	14.10
S271-K2	\$ 42.00	CB5	14.9	S273-K20NA	\$ 200.00	CB5	14.9	S281-K32	\$ 58.00	CB7	14.10
S271-K20	\$ 42.00	CB5	14.9	S273-K25	\$ 156.00	CB5	14.9	S281-K32W	\$ 58.00	CB7	14.11
S271-K20NA	\$ 84.00	CB5	14.9	S273-K25NA	\$ 206.00	CB5	14.9	S281-K3W	\$ 54.00	CB7	14.11
S271-K25	\$ 46.00	CB5	14.9	S273-K2NA	\$ 200.00	CB5	14.9	S281-K4	\$ 54.00	CB7	14.10
S271-K25NA	\$ 88.00	CB5	14.9	S273-K3	\$ 138.00	CB5	14.9	S281-K40	\$ 64.00	CB7	14.10
S271-K2NA	\$ 84.00	CB5	14.9	S273-K32	\$ 158.00	CB5	14.9	S281-K40W	\$ 64.00	CB7	14.11

S281-K4W – S282UC-K3

Alphanumeric

0

Catalog number	List price	Discount schedule	Page number	Catalog number	List price	Discount schedule	Page number	Catalog number	List price	Discount schedule	Page number
S281-K4W	\$ 54.00	CB7	14.11	S281UC-K16	\$ 104.00	CB7	14.12	S282-K10W	\$ 128.00	CB7	14.11
S281-K50	\$ 70.00	CB7	14.10	S281UC-K2	\$ 104.00	CB7	14.12	S282-K13	\$ 128.00	CB7	14.10
S281-K50W	\$ 70.00	CB7	14.11	S281UC-K20	\$ 104.00	CB7	14.12	S282-K13W	\$ 128.00	CB7	14.11
S281-K6	\$ 54.00	CB7	14.10	S281UC-K25	\$ 108.00	CB7	14.12	S282-K16	\$ 128.00	CB7	14.10
S281-K63	\$ 80.00	CB7	14.10	S281UC-K3	\$ 104.00	CB7	14.12	S282-K16W	\$ 128.00	CB7	14.11
S281-K63W	\$ 80.00	CB7	14.11	S281UC-K32	\$ 110.00	CB7	14.12	S282-K1W	\$ 128.00	CB7	14.11
S281-K6W	\$ 54.00	CB7	14.11	S281UC-K4	\$ 104.00	CB7	14.12	S282-K2	\$ 128.00	CB7	14.10
S281-K8	\$ 54.00	CB7	14.10	S281UC-K40	\$ 116.00	CB7	14.12	S282-K20	\$ 128.00	CB7	14.10
S281-K8W	\$ 54.00	CB7	14.11	S281UC-K50	\$ 136.00	CB7	14.12	S282-K20W	\$ 128.00	CB7	14.11
S281-KO.2	\$ 54.00	CB7	14.10	S281UC-K6	\$ 104.00	CB7	14.12	S282-K25	\$ 130.00	CB7	14.10
S281-KO.2W	\$ 54.00	CB7	14.11	S281UC-K63	\$ 152.00	CB7	14.12	S282-K25W	\$ 130.00	CB7	14.11
S281-KO.3	\$ 54.00	CB7	14.10	S281UC-K8	\$ 104.00	CB7	14.12	S282-K2W	\$ 128.00	CB7	14.11
S281-KO.3W	\$ 54.00	CB7	14.11	S281UC-KO.2	\$ 104.00	CB7	14.12	S282-K3	\$ 128.00	CB7	14.10
S281-KO.5	\$ 54.00	CB7	14.10	S281UC-KO.3	\$ 104.00	CB7	14.12	S282-K32	\$ 134.00	CB7	14.10
S281-KO.5W	\$ 54.00	CB7	14.11	S281UC-KO.5	\$ 104.00	CB7	14.12	S282-K32W	\$ 134.00	CB7	14.11
S281-KO.75	\$ 54.00	CB7	14.10	S281UC-KO.75	\$ 104.00	CB7	14.12	S282-K3W	\$ 128.00	CB7	14.11
S281-KO.75W	\$ 54.00	CB7	14.11	S281UC-Z1	\$ 168.00	CB7	14.13	S282-K4	\$ 128.00	CB7	14.10
S281-Z1	\$ 70.00	CB7	14.13	S281UC-Z1.6	\$ 168.00	CB7	14.13	S282-K40	\$ 134.00	CB7	14.10
S281-Z1.6	\$ 70.00	CB7	14.13	S281UC-Z10	\$ 168.00	CB7	14.13	S282-K40W	\$ 134.00	CB7	14.11
S281-Z10	\$ 70.00	CB7	14.13	S281UC-Z16	\$ 168.00	CB7	14.13	S282-K4W	\$ 128.00	CB7	14.11
S281-Z16	\$ 70.00	CB7	14.13	S281UC-Z2	\$ 168.00	CB7	14.13	S282-K50	\$ 162.00	CB7	14.10
S281-Z2	\$ 70.00	CB7	14.13	S281UC-Z20	\$ 168.00	CB7	14.13	S282-K50W	\$ 162.00	CB7	14.11
S281-Z20	\$ 70.00	CB7	14.13	S281UC-Z25	\$ 170.00	CB7	14.13	S282-K6	\$ 128.00	CB7	14.10
S281-Z25	\$ 70.00	CB7	14.13	S281UC-Z3	\$ 168.00	CB7	14.13	S282-K63	\$ 182.00	CB7	14.10
S281-Z3	\$ 70.00	CB7	14.13	S281UC-Z32	\$ 176.00	CB7	14.13	S282-K63W	\$ 182.00	CB7	14.11
S281-Z32	\$ 74.00	CB7	14.13	S281UC-Z4	\$ 168.00	CB7	14.13	S282-K6W	\$ 128.00	CB7	14.11
S281-Z4	\$ 70.00	CB7	14.13	S281UC-Z40	\$ 188.00	CB7	14.13	S282-K8	\$ 128.00	CB7	14.10
S281-Z40	\$ 78.00	CB7	14.13	S281UC-Z50	\$ 216.00	CB7	14.13	S282-K8W	\$ 128.00	CB7	14.11
S281-Z50	\$ 88.00	CB7	14.13	S281UC-Z6	\$ 168.00	CB7	14.13	S282-KO.2	\$ 128.00	CB7	14.10
S281-Z6	\$ 70.00	CB7	14.13	S281UC-Z63	\$ 242.00	CB7	14.13	S282-KO.2W	\$ 128.00	CB7	14.11
S281-Z63	\$ 100.00	CB7	14.13	S281UC-Z8	\$ 168.00	CB7	14.13	S282-KO.3	\$ 128.00	CB7	14.10
S281-Z8	\$ 70.00	CB7	14.13	S281UC-ZO.5	\$ 168.00	CB7	14.13	S282-KO.3W	\$ 128.00	CB7	14.11
S281-ZO.5	\$ 70.00	CB7	14.13	S281UX-K0.2	\$ 70.00	CB12	14.34	S282-KO.5	\$ 128.00	CB7	14.10
S281U-K0.2	\$ 70.00	CB12	14.34	S281UX-K0.3	\$ 70.00	CB12	14.34	S282-KO.5W	\$ 128.00	CB7	14.11
S281U-K0.3	\$ 70.00	CB12	14.34	S281UX-K0.5	\$ 70.00	CB12	14.34	S282-KO.75	\$ 128.00	CB7	14.10
S281U-K0.5	\$ 70.00	CB12	14.34	S281UX-K0.75	\$ 70.00	CB12	14.34	S282-KO.75W	\$ 128.00	CB7	14.11
S281U-K0.75	\$ 70.00	CB12	14.34	S281UX-K1	\$ 70.00	CB12	14.34	S282-Z1	\$ 162.00	CB7	14.13
S281U-K1	\$ 70.00	CB12	14.34	S281UX-K1.6	\$ 70.00	CB12	14.34	S282-Z1.6	\$ 162.00	CB7	14.13
S281U-K1.6	\$ 70.00	CB12	14.34	S281UX-K10	\$ 70.00	CB12	14.34	S282-Z10	\$ 162.00	CB7	14.13
S281U-K10	\$ 70.00	CB12	14.34	S281UX-K13	\$ 70.00	CB12	14.34	S282-Z16	\$ 162.00	CB7	14.13
S281U-K13	\$ 70.00	CB12	14.34	S281UX-K15	\$ 70.00	CB12	14.34	S282-Z2	\$ 162.00	CB7	14.13
S281U-K15	\$ 70.00	CB12	14.34	S281UX-K16	\$ 70.00	CB12	14.34	S282-Z20	\$ 162.00	CB7	14.13
S281U-K16	\$ 70.00	CB12	14.34	S281UX-K2	\$ 70.00	CB12	14.34	S282-Z25	\$ 184.00	CB7	14.13
S281U-K2	\$ 70.00	CB12	14.34	S281UX-K20	\$ 70.00	CB12	14.34	S282-Z3	\$ 162.00	CB7	14.13
S281U-K20	\$ 70.00	CB12	14.34	S281UX-K25	\$ 70.00	CB12	14.34	S282-Z32	\$ 170.00	CB7	14.13
S281U-K25	\$ 70.00	CB12	14.34	S281UX-K3	\$ 70.00	CB12	14.34	S282-Z4	\$ 162.00	CB7	14.13
S281U-K3	\$ 70.00	CB12	14.34	S281UX-K30	\$ 74.00	CB12	14.34	S282-Z40	\$ 176.00	CB7	14.13
S281U-K30	\$ 74.00	CB12	14.34	S281UX-K32	\$ 74.00	CB12	14.34	S282-Z50	\$ 206.00	CB7	14.13
S281U-K32	\$ 74.00	CB12	14.34	S281UX-K4	\$ 70.00	CB12	14.34	S282-Z6	\$ 162.00	CB7	14.13
S281U-K4	\$ 70.00	CB12	14.34	S281UX-K40	\$ 78.00	CB12	14.34	S282-Z63	\$ 232.00	CB7	14.13
S281U-K40	\$ 78.00	CB12	14.34	S281UX-K5	\$ 70.00	CB12	14.34	S282-Z8	\$ 162.00	CB7	14.13
S281U-K5	\$ 70.00	CB12	14.34	S281UX-K50	\$ 88.00	CB12	14.34	S282-ZO.5	\$ 162.00	CB7	14.13
S281U-K50	\$ 88.00	CB12	14.34	S281UX-K6	\$ 70.00	CB12	14.34	S282UC-K1	\$ 242.00	CB7	14.12
S281U-K6	\$ 70.00	CB12	14.34	S281UX-K60	\$ 100.00	CB12	14.34	S282UC-K1.6	\$ 242.00	CB7	14.12
S281U-K60	\$ 100.00	CB12	14.34	S281UX-K63	\$ 100.00	CB12	14.34	S282UC-K10	\$ 242.00	CB7	14.12
S281U-K63	\$ 100.00	CB12	14.34	S281UX-K8	\$ 70.00	CB12	14.34	S282UC-K16	\$ 242.00	CB7	14.12
S281U-K8	\$ 70.00	CB12	14.34	S282-K1	\$ 128.00	CB7	14.10	S282UC-K2	\$ 242.00	CB7	14.12
S281UC-K1	\$ 104.00	CB7	14.12	S282-K1.6	\$ 128.00	CB7	14.10	S282UC-K20	\$ 242.00	CB7	14.12
S281UC-K1.6	\$ 104.00	CB7	14.12	S282-K1.6W	\$ 128.00	CB7	14.11	S282UC-K25	\$ 248.00	CB7	14.12
S281UC-K10	\$ 104.00	CB7	14.12	S282-K10	\$ 128.00	CB7	14.10	S282UC-K3	\$ 242.00	CB7	14.12

S282UC-K32 – S294-C100

Catalog number	List price	Discount schedule	Page number	Catalog number	List price	Discount schedule	Page number	Catalog number	List price	Discount schedule	Page number
S282UC-K32	\$ 256.00	CB7	14.12	S283-K1W	\$ 194.00	CB7	14.11	S283UC-K63	\$ 534.00	CB7	14.12
S282UC-K4	\$ 242.00	CB7	14.12	S283-K2	\$ 194.00	CB7	14.10	S283UC-K8	\$ 370.00	CB7	14.12
S282UC-K40	\$ 266.00	CB7	14.12	S283-K20	\$ 194.00	CB7	14.10	S283UC-KO.2	\$ 370.00	CB7	14.12
S282UC-K50	\$ 312.00	CB7	14.12	S283-K20W	\$ 194.00	CB7	14.11	S283UC-KO.3	\$ 370.00	CB7	14.12
S282UC-K6	\$ 242.00	CB7	14.12	S283-K25	\$ 196.00	CB7	14.10	S283UC-KO.5	\$ 370.00	CB7	14.12
S282UC-K63	\$ 348.00	CB7	14.12	S283-K25W	\$ 196.00	CB7	14.11	S283UC-KO.75	\$ 370.00	CB7	14.12
S282UC-K8	\$ 242.00	CB7	14.12	S283-K2W	\$ 194.00	CB7	14.11	S283UC-Z1	\$ 594.00	CB7	14.13
S282UC-KO.2	\$ 242.00	CB7	14.12	S283-K3	\$ 194.00	CB7	14.10	S283UC-Z1.6	\$ 594.00	CB7	14.13
S282UC-KO.3	\$ 242.00	CB7	14.12	S283-K32	\$ 200.00	CB7	14.10	S283UC-Z10	\$ 594.00	CB7	14.13
S282UC-KO.5	\$ 242.00	CB7	14.12	S283-K32W	\$ 200.00	CB7	14.11	S283UC-Z16	\$ 594.00	CB7	14.13
S282UC-KO.75	\$ 242.00	CB7	14.12	S283-K3W	\$ 194.00	CB7	14.11	S283UC-Z2	\$ 594.00	CB7	14.13
S282UC-Z1	\$ 390.00	CB7	14.13	S283-K4	\$ 194.00	CB7	14.10	S283UC-Z20	\$ 594.00	CB7	14.13
S282UC-Z1.6	\$ 390.00	CB7	14.13	S283-K40	\$ 214.00	CB7	14.10	S283UC-Z25	\$ 603.00	CB7	14.13
S282UC-Z10	\$ 390.00	CB7	14.13	S283-K40W	\$ 214.00	CB7	14.11	S283UC-Z3	\$ 594.00	CB7	14.13
S282UC-Z16	\$ 390.00	CB7	14.13	S283-K4W	\$ 194.00	CB7	14.11	S283UC-Z32	\$ 612.00	CB7	14.13
S282UC-Z2	\$ 390.00	CB7	14.13	S283-K50	\$ 246.00	CB7	14.10	S283UC-Z4	\$ 594.00	CB7	14.13
S282UC-Z20	\$ 390.00	CB7	14.13	S283-K50W	\$ 246.00	CB7	14.11	S283UC-Z40	\$ 657.00	CB7	14.13
S282UC-Z25	\$ 398.00	CB7	14.13	S283-K6	\$ 194.00	CB7	14.10	S283UC-Z50	\$ 756.00	CB7	14.13
S282UC-Z3	\$ 390.00	CB7	14.13	S283-K63	\$ 280.00	CB7	14.10	S283UC-Z6	\$ 594.00	CB7	14.13
S282UC-Z32	\$ 410.00	CB7	14.13	S283-K63W	\$ 280.00	CB7	14.11	S283UC-Z63	\$ 855.00	CB7	14.13
S282UC-Z4	\$ 390.00	CB7	14.13	S283-K6W	\$ 194.00	CB7	14.11	S283UC-Z8	\$ 594.00	CB7	14.13
S282UC-Z40	\$ 426.00	CB7	14.13	S283-K8	\$ 194.00	CB7	14.10	S283UC-ZO.5	\$ 594.00	CB7	14.13
S282UC-Z50	\$ 498.00	CB7	14.13	S283-K8W	\$ 194.00	CB7	14.11	S283UX-KO.2	\$ 244.00	CB12	14.34
S282UC-Z6	\$ 390.00	CB7	14.13	S283-KO.2	\$ 194.00	CB7	14.10	S283UX-KO.3	\$ 244.00	CB12	14.34
S282UC-Z63	\$ 558.00	CB7	14.13	S283-KO.2W	\$ 194.00	CB7	14.11	S283UX-KO.5	\$ 244.00	CB12	14.34
S282UC-Z8	\$ 390.00	CB7	14.13	S283-KO.3	\$ 194.00	CB7	14.10	S283UX-KO.75	\$ 244.00	CB12	14.34
S282UC-ZO.5	\$ 390.00	CB7	14.13	S283-KO.3W	\$ 194.00	CB7	14.11	S283UX-K1	\$ 244.00	CB12	14.34
S282UX-KO.2	\$ 162.00	CB12	14.34	S283-KO.5	\$ 194.00	CB7	14.10	S283UX-K1.6	\$ 244.00	CB12	14.34
S282UX-KO.3	\$ 162.00	CB12	14.34	S283-KO.5W	\$ 194.00	CB7	14.11	S283UX-K10	\$ 244.00	CB12	14.34
S282UX-KO.5	\$ 162.00	CB12	14.34	S283-KO.75	\$ 194.00	CB7	14.10	S283UX-K13	\$ 244.00	CB12	14.34
S282UX-KO.75	\$ 162.00	CB12	14.34	S283-KO.75W	\$ 194.00	CB7	14.11	S283UX-K15	\$ 244.00	CB12	14.34
S282UX-K1	\$ 162.00	CB12	14.34	S283-Z1	\$ 244.00	CB7	14.13	S283UX-K16	\$ 244.00	CB12	14.34
S282UX-K1.6	\$ 162.00	CB12	14.34	S283-Z1.6	\$ 244.00	CB7	14.13	S283UX-K2	\$ 244.00	CB12	14.34
S282UX-K10	\$ 162.00	CB12	14.34	S283-Z10	\$ 244.00	CB7	14.13	S283UX-K20	\$ 244.00	CB12	14.34
S282UX-K13	\$ 162.00	CB12	14.34	S283-Z16	\$ 244.00	CB7	14.13	S283UX-K25	\$ 244.00	CB12	14.34
S282UX-K15	\$ 162.00	CB12	14.34	S283-Z2	\$ 244.00	CB7	14.13	S283UX-K3	\$ 244.00	CB12	14.34
S282UX-K16	\$ 162.00	CB12	14.34	S283-Z20	\$ 244.00	CB7	14.13	S283UX-K30	\$ 254.00	CB12	14.34
S282UX-K2	\$ 162.00	CB12	14.34	S283-Z25	\$ 248.00	CB7	14.13	S283UX-K32	\$ 254.00	CB12	14.34
S282UX-K20	\$ 162.00	CB12	14.34	S283-Z3	\$ 244.00	CB7	14.13	S283UX-K4	\$ 244.00	CB12	14.34
S282UX-K25	\$ 162.00	CB12	14.34	S283-Z32	\$ 254.00	CB7	14.13	S283UX-K40	\$ 266.00	CB12	14.34
S282UX-K3	\$ 162.00	CB12	14.34	S283-Z4	\$ 244.00	CB7	14.13	S283UX-K5	\$ 244.00	CB12	14.34
S282UX-K30	\$ 170.00	CB12	14.34	S283-Z40	\$ 266.00	CB7	14.13	S283UX-K50	\$ 306.00	CB12	14.34
S282UX-K32	\$ 170.00	CB12	14.34	S283-Z50	\$ 306.00	CB7	14.13	S283UX-K6	\$ 244.00	CB12	14.34
S282UX-K4	\$ 162.00	CB12	14.34	S283-Z6	\$ 244.00	CB7	14.13	S283UX-K60	\$ 344.00	CB12	14.34
S282UX-K40	\$ 176.00	CB12	14.34	S283-Z63	\$ 344.00	CB7	14.13	S283UX-K63	\$ 344.00	CB12	14.34
S282UX-K5	\$ 162.00	CB12	14.34	S283-Z8	\$ 244.00	CB7	14.13	S283UX-K8	\$ 244.00	CB12	14.34
S282UX-K50	\$ 206.00	CB12	14.34	S283-ZO.5	\$ 244.00	CB7	14.13	S290-A1	\$ 144.00	CB9	14.14
S282UX-K6	\$ 162.00	CB12	14.34	S283UC-K1	\$ 370.00	CB7	14.12	S290-A2	\$ 144.00	CB9	14.14
S282UX-K60	\$ 232.00	CB12	14.34	S283UC-K1.6	\$ 370.00	CB7	14.12	S290-H11	\$ 72.00	CB9	14.14
S282UX-K63	\$ 232.00	CB12	14.34	S283UC-K10	\$ 370.00	CB7	14.12	S290-S	\$ 112.00	CB9	14.14
S282UX-K8	\$ 162.00	CB12	14.34	S283UC-K16	\$ 370.00	CB7	14.12	S291-C100	\$ 144.00	CB9	14.14
S283-K1	\$ 194.00	CB7	14.10	S283UC-K2	\$ 370.00	CB7	14.12	S291-C125	\$ 192.00	CB9	14.14
S283-K1.6	\$ 194.00	CB7	14.10	S283UC-K20	\$ 370.00	CB7	14.12	S291-C80	\$ 138.00	CB9	14.14
S283-K1.6W	\$ 194.00	CB7	14.11	S283UC-K25	\$ 382.00	CB7	14.12	S292-C100	\$ 364.00	CB9	14.14
S283-K10	\$ 194.00	CB7	14.10	S283UC-K3	\$ 370.00	CB7	14.12	S292-C125	\$ 568.00	CB9	14.14
S283-K10W	\$ 194.00	CB7	14.11	S283UC-K32	\$ 408.00	CB7	14.12	S292-C80	\$ 340.00	CB9	14.14
S283-K13	\$ 194.00	CB7	14.10	S283UC-K4	\$ 370.00	CB7	14.12	S293-C100	\$ 548.00	CB9	14.14
S283-K13W	\$ 194.00	CB7	14.11	S283UC-K40	\$ 448.00	CB7	14.12	S293-C125	\$ 732.00	CB9	14.14
S283-K16	\$ 194.00	CB7	14.10	S283UC-K50	\$ 472.00	CB7	14.12	S293-C80	\$ 536.00	CB9	14.14
S283-K16W	\$ 194.00	CB7	14.11	S283UC-K6	\$ 370.00	CB7	14.12	S294-C100	\$ 756.00	CB9	14.14

S294-C125 – S3NQ040TW

Alphanumeric

0

Catalog number	List price	Discount schedule	Page number	Catalog number	List price	Discount schedule	Page number	Catalog number	List price	Discount schedule	Page number
S294-C125	\$ 948.00	CB9	14.14	S3HQ050TW	\$ 688.00	S3	15.33	S3LQ050TW	\$ 916.00	S3	15.33
S294-C80	\$ 740.00	CB9	14.14	S3HQ060TW	\$ 688.00	S3	15.33	S3LQ060TW	\$ 916.00	S3	15.33
S2C-DH	\$ 76.00	CB8	14.19	S3HQ070TW	\$ 780.00	S3	15.33	S3LQ070TW	\$ 1,123.00	S3	15.33
S2E-1	\$ 200.00	SE	15.66	S3HQ080TW	\$ 780.00	S3	15.33	S3LQ080TW	\$ 1,123.00	S3	15.33
S2E-3R12	\$ 305.00	SE	15.66	S3HQ090TW	\$ 780.00	S3	15.33	S3LQ090TW	\$ 1,123.00	S3	15.33
S2NK125	\$ 100.00	SE	15.66	S3HQ100TW	\$ 780.00	S3	15.33	S3LQ100TW	\$ 1,123.00	S3	15.33
S3B175TW	\$ 590.00	S3	15.32	S3HQ125TW	\$ 1,762.00	S3	15.33	S3LQ125TW	\$ 2,511.00	S3	15.33
S3B175TW-2	\$ 460.00	S3	15.32	S3HQ150TW	\$ 1,762.00	S3	15.33	S3LQ150TW	\$ 2,511.00	S3	15.33
S3B200TW	\$ 590.00	S3	15.32	S3HQ175TW	\$ 1,762.00	S3	15.33	S3LQ175TW	\$ 2,511.00	S3	15.33
S3B200TW-2	\$ 460.00	S3	15.32	S3HQ200TW	\$ 1,762.00	S3	15.33	S3LQ200TW	\$ 2,511.00	S3	15.33
S3B225DW	\$ 410.00	S3	15.34	S3HQ225TW	\$ 1,762.00	S3	15.33	S3LQ225TW	\$ 2,511.00	S3	15.33
S3B225TW	\$ 590.00	S3	15.32	S3L003MW	\$ 710.00	SM	15.34	S3N003MW	\$ 568.00	SM	15.34
S3B225TW-2	\$ 460.00	S3	15.32	S3L005MW	\$ 710.00	SM	15.34	S3N005MW	\$ 568.00	SM	15.34
S3D100W	\$ 531.00	S3	15.34	S3L010MW	\$ 710.00	SM	15.34	S3N010MW	\$ 568.00	SM	15.34
S3D160W	\$ 892.00	S3	15.34	S3L015TW	\$ 824.00	S3	15.32	S3N015TW	\$ 413.00	S3	15.32
S3D250W	\$ 1,393.00	S3	15.34	S3L015TW-2	\$ 634.00	S3	15.32	S3N015TW-2	\$ 316.00	S3	15.32
S3E-1	\$ 235.00	SE	15.66	S3L020TW	\$ 824.00	S3	15.32	S3N020TW	\$ 413.00	S3	15.32
S3E-3R12	\$ 395.00	SE	15.66	S3L020TW-2	\$ 634.00	S3	15.32	S3N020TW-2	\$ 316.00	S3	15.32
S3H015TW	\$ 619.00	S3	15.32	S3L025MW	\$ 710.00	SM	15.34	S3N025MW	\$ 568.00	SM	15.34
S3H015TW-2	\$ 527.00	S3	15.32	S3L025TW	\$ 824.00	S3	15.32	S3N025TW	\$ 413.00	S3	15.32
S3H020TW	\$ 619.00	S3	15.32	S3L025TW-2	\$ 634.00	S3	15.32	S3N025TW-2	\$ 316.00	S3	15.32
S3H020TW-2	\$ 527.00	S3	15.32	S3L030TW	\$ 824.00	S3	15.32	S3N030TW	\$ 413.00	S3	15.32
S3H025TW	\$ 619.00	S3	15.32	S3L030TW-2	\$ 634.00	S3	15.32	S3N030TW-2	\$ 316.00	S3	15.32
S3H025TW-2	\$ 527.00	S3	15.32	S3L035TW	\$ 824.00	S3	15.32	S3N035TW	\$ 413.00	S3	15.32
S3H030TW	\$ 619.00	S3	15.32	S3L035TW-2	\$ 634.00	S3	15.32	S3N035TW-2	\$ 316.00	S3	15.32
S3H030TW-2	\$ 527.00	S3	15.32	S3L040TW	\$ 824.00	S3	15.32	S3N040TW	\$ 413.00	S3	15.32
S3H035TW	\$ 619.00	S3	15.32	S3L040TW-2	\$ 634.00	S3	15.32	S3N040TW-2	\$ 316.00	S3	15.32
S3H035TW-2	\$ 527.00	S3	15.32	S3L050MW	\$ 710.00	SM	15.34	S3N050MW	\$ 633.00	SM	15.34
S3H040TW	\$ 619.00	S3	15.32	S3L050TW	\$ 824.00	S3	15.32	S3N050TW	\$ 413.00	S3	15.32
S3H040TW-2	\$ 527.00	S3	15.32	S3L050TW-2	\$ 634.00	S3	15.32	S3N050TW-2	\$ 316.00	S3	15.32
S3H050TW	\$ 619.00	S3	15.32	S3L060TW	\$ 824.00	S3	15.32	S3N060TW	\$ 413.00	S3	15.32
S3H050TW-2	\$ 527.00	S3	15.32	S3L060TW-2	\$ 634.00	S3	15.32	S3N060TW-2	\$ 316.00	S3	15.32
S3H060TW	\$ 619.00	S3	15.32	S3L070TW	\$ 1,010.00	S3	15.32	S3N070TW	\$ 504.00	S3	15.32
S3H060TW-2	\$ 527.00	S3	15.32	S3L070TW-2	\$ 816.00	S3	15.32	S3N070TW-2	\$ 407.00	S3	15.32
S3H070TW	\$ 702.00	S3	15.32	S3L080TW	\$ 1,010.00	S3	15.32	S3N080TW	\$ 504.00	S3	15.32
S3H070TW-2	\$ 617.00	S3	15.32	S3L080TW-2	\$ 816.00	S3	15.32	S3N080TW-2	\$ 407.00	S3	15.32
S3H080TW	\$ 702.00	S3	15.32	S3L090TW	\$ 1,010.00	S3	15.32	S3N090TW	\$ 504.00	S3	15.32
S3H080TW-2	\$ 617.00	S3	15.32	S3L090TW-2	\$ 816.00	S3	15.32	S3N090TW-2	\$ 407.00	S3	15.32
S3H090TW	\$ 702.00	S3	15.32	S3L100MW	\$ 843.00	SM	15.34	S3N100MW	\$ 763.00	SM	15.34
S3H090TW-2	\$ 617.00	S3	15.32	S3L100TW	\$ 1,010.00	S3	15.32	S3N100TW	\$ 504.00	S3	15.32
S3H100TW	\$ 702.00	S3	15.32	S3L100TW-2	\$ 816.00	S3	15.32	S3N100TW-2	\$ 407.00	S3	15.32
S3H100TW-2	\$ 617.00	S3	15.32	S3L125MW	\$ 1,910.00	SM	15.34	S3N125MW	\$ 929.00	SM	15.34
S3H125TW	\$ 1,586.00	S3	15.32	S3L125TW	\$ 2,260.00	S3	15.32	S3N125TW	\$ 1,131.00	S3	15.32
S3H125TW-2	\$ 1,376.00	S3	15.32	S3L125TW-2	\$ 1,818.00	S3	15.32	S3N125TW-2	\$ 911.00	S3	15.32
S3H150DW	\$ 892.00	S3	15.34	S3L150MW	\$ 1,910.00	SM	15.34	S3N150MW	\$ 929.00	SM	15.34
S3H150TW	\$ 1,586.00	S3	15.32	S3L150TW	\$ 2,260.00	S3	15.32	S3N150TW	\$ 1,131.00	S3	15.32
S3H150TW-2	\$ 1,376.00	S3	15.32	S3L150TW-2	\$ 1,818.00	S3	15.32	S3N150TW-2	\$ 911.00	S3	15.32
S3H175TW	\$ 1,586.00	S3	15.32	S3L175TW	\$ 2,260.00	S3	15.32	S3N175TW	\$ 1,131.00	S3	15.32
S3H175TW-2	\$ 1,376.00	S3	15.32	S3L175TW-2	\$ 1,818.00	S3	15.32	S3N175TW-2	\$ 911.00	S3	15.32
S3H200TW	\$ 1,586.00	S3	15.32	S3L200MW	\$ 1,910.00	SM	15.34	S3N200TW	\$ 1,131.00	S3	15.32
S3H200TW-2	\$ 1,376.00	S3	15.32	S3L200TW	\$ 2,260.00	S3	15.32	S3N200TW-2	\$ 911.00	S3	15.32
S3H225DW	\$ 1,254.00	S3	15.34	S3L200TW-2	\$ 1,818.00	S3	15.32	S3N225TW	\$ 1,131.00	S3	15.32
S3H225TW	\$ 1,586.00	S3	15.32	S3L225TW	\$ 2,260.00	S3	15.32	S3N225TW-2	\$ 911.00	S3	15.32
S3H225TW-2	\$ 1,376.00	S3	15.32	S3L225TW-2	\$ 1,818.00	S3	15.32	S3NK225	\$ 135.00	SE	15.66
S3HQ015TW	\$ 688.00	S3	15.33	S3LQ015TW	\$ 916.00	S3	15.33	S3NQ015TW	\$ 459.00	S3	15.33
S3HQ020TW	\$ 688.00	S3	15.33	S3LQ020TW	\$ 916.00	S3	15.33	S3NQ020TW	\$ 459.00	S3	15.33
S3HQ025TW	\$ 688.00	S3	15.33	S3LQ025TW	\$ 916.00	S3	15.33	S3NQ025TW	\$ 459.00	S3	15.33
S3HQ030TW	\$ 688.00	S3	15.33	S3LQ030TW	\$ 916.00	S3	15.33	S3NQ030TW	\$ 459.00	S3	15.33
S3HQ035TW	\$ 688.00	S3	15.33	S3LQ035TW	\$ 916.00	S3	15.33	S3NQ035TW	\$ 459.00	S3	15.33
S3HQ040TW	\$ 688.00	S3	15.33	S3LQ040TW	\$ 916.00	S3	15.33	S3NQ040TW	\$ 459.00	S3	15.33

S3NQ050TW – S502-B32

Catalog number	List price	Discount schedule	Page number	Catalog number	List price	Discount schedule	Page number	Catalog number	List price	Discount schedule	Page number
S3NQ050TW	\$ 459.00	S3	15.33	S4N100EW	\$ 2,813.00	S4	15.36	S501-D50	\$ 210.00	CB10	14.38
S3NQ060TW	\$ 459.00	S3	15.33	S4N100MW	\$ 1,347.00	S4	15.38	S501-D63	\$ 226.00	CB10	14.38
S3NQ070TW	\$ 560.00	S3	15.33	S4N100MW-2	\$ 1,073.00	S4	15.38	S501-K0.15	\$ 182.00	CB10	14.39
S3NQ080TW	\$ 560.00	S3	15.33	S4N250BW	\$ 1,347.00	S4	15.36	S501-K0.21	\$ 182.00	CB10	14.39
S3NQ090TW	\$ 560.00	S3	15.33	S4N250BW-2	\$ 1,073.00	S4	15.36	S501-K0.3	\$ 182.00	CB10	14.39
S3NQ100TW	\$ 560.00	S3	15.33	S4N250CW	\$ 1,913.00	S4	15.36	S501-K0.42	\$ 182.00	CB10	14.39
S3NQ125TW	\$ 1,257.00	S3	15.33	S4N250CW-2	\$ 1,679.00	S4	15.36	S501-K0.58	\$ 182.00	CB10	14.39
S3NQ150TW	\$ 1,257.00	S3	15.33	S4N250EW	\$ 2,813.00	S4	15.36	S501-K0.8	\$ 182.00	CB10	14.39
S3NQ175TW	\$ 1,257.00	S3	15.33	S4N250MW	\$ 1,347.00	S4	15.38	S501-K1.1	\$ 182.00	CB10	14.39
S3NQ200TW	\$ 1,257.00	S3	15.33	S4N250MW-2	\$ 1,073.00	S4	15.38	S501-K1.5	\$ 182.00	CB10	14.39
S3NQ225TW	\$ 1,257.00	S3	15.33	S4NK240	\$ 155.00	SE	15.66	S501-K11	\$ 182.00	CB10	14.39
S4-M1	\$ 81.00	MA	5.17	S4NQ100BW	\$ 1,482.00	S4	15.37	S501-K15	\$ 182.00	CB10	14.39
S460SRF3-70*6F	\$ 32,025.00	ACE	3.54	S4NQ100CW	\$ 2,104.00	S4	15.37	S501-K2.1	\$ 182.00	CB10	14.39
S4E-1	\$ 305.00	SE	15.66	S4NQ100EW	\$ 3,094.00	S4	15.37	S501-K20	\$ 182.00	CB10	14.39
S4E-3R12	\$ 575.00	SE	15.66	S4NQ250BW	\$ 1,482.00	S4	15.37	S501-K26	\$ 182.00	CB10	14.39
S4H100BW	\$ 3,030.00	S4	15.36	S4NQ250CW	\$ 2,104.00	S4	15.37	S501-K3	\$ 182.00	CB10	14.39
S4H100BW-2	\$ 2,572.00	S4	15.36	S4NQ250EW	\$ 3,094.00	S4	15.37	S501-K32	\$ 202.00	CB10	14.39
S4H100CW	\$ 3,596.00	S4	15.36	S500-BB23	\$ 56.00	CB8	14.42	S501-K37	\$ 202.00	CB10	14.39
S4H100CW-2	\$ 3,138.00	S4	15.36	S500-BB33	\$ 95.00	CB8	14.42	S501-K4.2	\$ 182.00	CB10	14.39
S4H100EW	\$ 4,496.00	S4	15.36	S500-BB43	\$ 132.00	CB8	14.42	S501-K41	\$ 226.00	CB10	14.39
S4H100MW	\$ 3,030.00	S4	15.38	S500-BB53	\$ 171.00	CB8	14.42	S501-K5.8	\$ 182.00	CB10	14.39
S4H100MW-2	\$ 2,572.00	S4	15.38	S500-BB63	\$ 208.00	CB8	14.42	S501-K8	\$ 182.00	CB10	14.39
S4H250BW	\$ 3,030.00	S4	15.36	S500-H02	\$ 84.00	CB8	14.42	S501K45	\$ 226.00	CB10	14.39
S4H250BW-2	\$ 2,572.00	S4	15.36	S500-H11	\$ 84.00	CB8	14.42	S501UC-B10	\$ 226.00	CB10	14.40
S4H250CW	\$ 3,596.00	S4	15.36	S500-H20	\$ 84.00	CB8	14.42	S501UC-B13	\$ 226.00	CB10	14.40
S4H250CW-2	\$ 3,138.00	S4	15.36	S500-K1	\$ 16.00	CB8	14.19	S501UC-B16	\$ 226.00	CB10	14.40
S4H250DW	\$ 1,215.00	S4	15.38	S500-K2	\$ 25.00	CB8	14.42	S501UC-B20	\$ 226.00	CB10	14.40
S4H250EW	\$ 4,496.00	S4	15.36	S500-ME1	\$ 60.00	CB8	14.19	S501UC-B25	\$ 226.00	CB10	14.40
S4H250MW	\$ 3,030.00	S4	15.38	S500-ME2	\$ 70.00	CB8	14.19	S501UC-B32	\$ 226.00	CB10	14.40
S4H250MW-2	\$ 2,572.00	S4	15.38	S500-ME3	\$ 80.00	CB8	14.19	S501UC-B40	\$ 226.00	CB10	14.40
S4HQ100BW	\$ 3,333.00	S4	15.37	S500-RD3	\$ 100.00	CB8	14.42	S501UC-B50	\$ 258.00	CB10	14.40
S4HQ100CW	\$ 3,956.00	S4	15.37	S500-S02	\$ 92.00	CB8	14.42	S501UC-B6	\$ 226.00	CB10	14.40
S4HQ100EW	\$ 4,946.00	S4	15.37	S500-S11	\$ 92.00	CB8	14.42	S501UC-B63	\$ 292.00	CB10	14.40
S4HQ250BW	\$ 3,333.00	S4	15.37	S500-S20	\$ 92.00	CB8	14.42	S501UC-K0.15	\$ 250.00	CB10	14.41
S4HQ250CW	\$ 3,956.00	S4	15.37	S501-B10	\$ 168.00	CB10	14.38	S501UC-K0.21	\$ 250.00	CB10	14.41
S4HQ250EW	\$ 4,946.00	S4	15.37	S501-B13	\$ 168.00	CB10	14.38	S501UC-K0.3	\$ 250.00	CB10	14.41
S4L100BW	\$ 3,950.00	S4	15.36	S501-B16	\$ 168.00	CB10	14.38	S501UC-K0.42	\$ 250.00	CB10	14.41
S4L100BW-2	\$ 3,159.00	S4	15.36	S501-B20	\$ 168.00	CB10	14.38	S501UC-K0.58	\$ 250.00	CB10	14.41
S4L100CW	\$ 4,516.00	S4	15.36	S501-B25	\$ 168.00	CB10	14.38	S501UC-K0.8	\$ 250.00	CB10	14.41
S4L100CW-2	\$ 3,725.00	S4	15.36	S501-B32	\$ 168.00	CB10	14.38	S501UC-K1.1	\$ 250.00	CB10	14.41
S4L100EW	\$ 5,416.00	S4	15.36	S501-B40	\$ 168.00	CB10	14.38	S501UC-K1.5	\$ 250.00	CB10	14.41
S4L100MW	\$ 3,950.00	S4	15.38	S501-B50	\$ 186.00	CB10	14.38	S501UC-K11	\$ 250.00	CB10	14.41
S4L100MW-2	\$ 3,159.00	S4	15.38	S501-B6	\$ 168.00	CB10	14.38	S501UC-K15	\$ 250.00	CB10	14.41
S4L250BW	\$ 3,950.00	S4	15.36	S501-B63	\$ 202.00	CB10	14.38	S501UC-K2.1	\$ 250.00	CB10	14.41
S4L250BW-2	\$ 3,159.00	S4	15.36	S501-C10	\$ 168.00	CB10	14.38	S501UC-K20	\$ 250.00	CB10	14.41
S4L250CW	\$ 4,516.00	S4	15.36	S501-C13	\$ 168.00	CB10	14.38	S501UC-K26	\$ 250.00	CB10	14.41
S4L250CW-2	\$ 3,725.00	S4	15.36	S501-C16	\$ 168.00	CB10	14.38	S501UC-K3	\$ 250.00	CB10	14.41
S4L250EW	\$ 5,416.00	S4	15.36	S501-C20	\$ 168.00	CB10	14.38	S501UC-K32	\$ 286.00	CB10	14.41
S4L250MW	\$ 3,950.00	S4	15.38	S501-C25	\$ 168.00	CB10	14.38	S501UC-K37	\$ 286.00	CB10	14.41
S4L250MW-2	\$ 3,159.00	S4	15.38	S501-C32	\$ 168.00	CB10	14.38	S501UC-K4.2	\$ 250.00	CB10	14.41
S4LQ100BW	\$ 4,345.00	S4	15.37	S501-C40	\$ 168.00	CB10	14.38	S501UC-K41	\$ 320.00	CB10	14.41
S4LQ100CW	\$ 4,968.00	S4	15.37	S501-C50	\$ 184.00	CB10	14.38	S501UC-K45	\$ 320.00	CB10	14.41
S4LQ100EW	\$ 5,958.00	S4	15.37	S501-C6	\$ 168.00	CB10	14.38	S501UC-K5.8	\$ 250.00	CB10	14.41
S4LQ250BW	\$ 4,345.00	S4	15.37	S501-C63	\$ 202.00	CB10	14.38	S501UC-K8	\$ 250.00	CB10	14.41
S4LQ250CW	\$ 4,968.00	S4	15.37	S501-D13	\$ 190.00	CB10	14.38	S502-B10	\$ 328.00	CB10	14.38
S4LQ250EW	\$ 5,958.00	S4	15.37	S501-D16	\$ 190.00	CB10	14.38	S502-B13	\$ 328.00	CB10	14.38
S4N100BW	\$ 1,347.00	S4	15.36	S501-D20	\$ 190.00	CB10	14.38	S502-B16	\$ 328.00	CB10	14.38
S4N100BW-2	\$ 1,073.00	S4	15.36	S501-D25	\$ 190.00	CB10	14.38	S502-B20	\$ 328.00	CB10	14.38
S4N100CW	\$ 1,913.00	S4	15.36	S501-D32	\$ 190.00	CB10	14.38	S502-B25	\$ 328.00	CB10	14.38
S4N100CW-2	\$ 1,679.00	S4	15.36	S501-D40	\$ 190.00	CB10	14.38	S502-B32	\$ 328.00	CB10	14.38

S502-B40 – S504UC-K37

Alphanumeric

0

Catalog number	List price	Discount schedule	Page number	Catalog number	List price	Discount schedule	Page number	Catalog number	List price	Discount schedule	Page number
S502-B40	\$ 328.00	CB10	14.38	S502UC-K1.5	\$ 488.00	CB10	14.41	S503-K45	\$ 828.00	CB10	14.39
S502-B50	\$ 362.00	CB10	14.38	S502UC-K11	\$ 488.00	CB10	14.41	S503-K5.8	\$ 518.00	CB10	14.39
S502-B6	\$ 328.00	CB10	14.38	S502UC-K15	\$ 488.00	CB10	14.41	S503-K8	\$ 518.00	CB10	14.39
S502-B63	\$ 392.00	CB10	14.38	S502UC-K2.1	\$ 488.00	CB10	14.41	S503UC-B10	\$ 646.00	CB10	14.40
S502-C10	\$ 328.00	CB10	14.38	S502UC-K20	\$ 488.00	CB10	14.41	S503UC-B13	\$ 646.00	CB10	14.40
S502-C13	\$ 328.00	CB10	14.38	S502UC-K26	\$ 488.00	CB10	14.41	S503UC-B16	\$ 646.00	CB10	14.40
S502-C16	\$ 328.00	CB10	14.38	S502UC-K3	\$ 488.00	CB10	14.41	S503UC-B20	\$ 646.00	CB10	14.40
S502-C20	\$ 328.00	CB10	14.38	S502UC-K32	\$ 558.00	CB10	14.41	S503UC-B25	\$ 646.00	CB10	14.40
S502-C25	\$ 328.00	CB10	14.38	S502UC-K37	\$ 558.00	CB10	14.41	S503UC-B32	\$ 646.00	CB10	14.40
S502-C32	\$ 328.00	CB10	14.38	S502UC-K4.2	\$ 488.00	CB10	14.41	S503UC-B40	\$ 646.00	CB10	14.40
S502-C40	\$ 328.00	CB10	14.38	S502UC-K41	\$ 622.00	CB10	14.41	S503UC-B50	\$ 734.00	CB10	14.40
S502-C50	\$ 362.00	CB10	14.38	S502UC-K45	\$ 622.00	CB10	14.41	S503UC-B6	\$ 646.00	CB10	14.40
S502-C6	\$ 328.00	CB10	14.38	S502UC-K5.8	\$ 488.00	CB10	14.41	S503UC-B63	\$ 832.00	CB10	14.40
S502-C63	\$ 392.00	CB10	14.38	S502UC-K8	\$ 488.00	CB10	14.41	S503UC-K0.15	\$ 712.00	CB10	14.41
S502-D13	\$ 372.00	CB10	14.38	S503-B10	\$ 478.00	CB10	14.38	S503UC-K0.21	\$ 712.00	CB10	14.41
S502-D16	\$ 372.00	CB10	14.38	S503-B13	\$ 478.00	CB10	14.38	S503UC-K0.3	\$ 712.00	CB10	14.41
S502-D20	\$ 372.00	CB10	14.38	S503-B16	\$ 478.00	CB10	14.38	S503UC-K0.42	\$ 712.00	CB10	14.41
S502-D25	\$ 372.00	CB10	14.38	S503-B20	\$ 478.00	CB10	14.38	S503UC-K0.58	\$ 712.00	CB10	14.41
S502-D32	\$ 372.00	CB10	14.38	S503-B25	\$ 478.00	CB10	14.38	S503UC-K0.8	\$ 712.00	CB10	14.41
S502-D40	\$ 372.00	CB10	14.38	S503-B32	\$ 478.00	CB10	14.38	S503UC-K1.1	\$ 712.00	CB10	14.41
S502-D50	\$ 408.00	CB10	14.38	S503-B40	\$ 478.00	CB10	14.38	S503UC-K1.5	\$ 712.00	CB10	14.41
S502-D63	\$ 442.00	CB10	14.38	S503-B50	\$ 526.00	CB10	14.38	S503UC-K11	\$ 712.00	CB10	14.41
S502-K0.15	\$ 356.00	CB10	14.39	S503-B6	\$ 478.00	CB10	14.38	S503UC-K15	\$ 712.00	CB10	14.41
S502-K0.21	\$ 356.00	CB10	14.39	S503-B63	\$ 574.00	CB10	14.38	S503UC-K2.1	\$ 712.00	CB10	14.41
S502-K0.3	\$ 356.00	CB10	14.39	S503-C10	\$ 478.00	CB10	14.38	S503UC-K20	\$ 712.00	CB10	14.41
S502-K0.42	\$ 356.00	CB10	14.39	S503-C13	\$ 478.00	CB10	14.38	S503UC-K26	\$ 712.00	CB10	14.41
S502-K0.58	\$ 356.00	CB10	14.39	S503-C16	\$ 478.00	CB10	14.38	S503UC-K3	\$ 712.00	CB10	14.41
S502-K1.1	\$ 356.00	CB10	14.39	S503-C20	\$ 478.00	CB10	14.38	S503UC-K32	\$ 814.00	CB10	14.41
S502-K1.5	\$ 356.00	CB10	14.39	S503-C25	\$ 478.00	CB10	14.38	S503UC-K37	\$ 814.00	CB10	14.41
S502-K11	\$ 356.00	CB10	14.39	S503-C32	\$ 478.00	CB10	14.38	S503UC-K4.2	\$ 712.00	CB10	14.41
S502-K15	\$ 356.00	CB10	14.39	S503-C40	\$ 478.00	CB10	14.38	S503UC-K41	\$ 910.00	CB10	14.41
S502-K2.1	\$ 356.00	CB10	14.39	S503-C50	\$ 526.00	CB10	14.38	S503UC-K45	\$ 910.00	CB10	14.41
S502-K20	\$ 356.00	CB10	14.39	S503-C6	\$ 478.00	CB10	14.38	S503UC-K5.8	\$ 712.00	CB10	14.41
S502-K26	\$ 356.00	CB10	14.39	S503-C63	\$ 574.00	CB10	14.38	S503UC-K8	\$ 712.00	CB10	14.41
S502-K3	\$ 356.00	CB10	14.39	S503-D13	\$ 544.00	CB10	14.38	S504UC-B10	\$ 908.00	CB10	14.40
S502-K32	\$ 392.00	CB10	14.39	S503-D16	\$ 544.00	CB10	14.38	S504UC-B13	\$ 908.00	CB10	14.40
S502-K37	\$ 392.00	CB10	14.39	S503-D20	\$ 544.00	CB10	14.38	S504UC-B16	\$ 908.00	CB10	14.40
S502-K4.2	\$ 356.00	CB10	14.39	S503-D25	\$ 544.00	CB10	14.38	S504UC-B20	\$ 908.00	CB10	14.40
S502-K41	\$ 442.00	CB10	14.39	S503-D32	\$ 544.00	CB10	14.38	S504UC-B25	\$ 908.00	CB10	14.40
S502-K45	\$ 442.00	CB10	14.39	S503-D40	\$ 544.00	CB10	14.38	S504UC-B32	\$ 908.00	CB10	14.40
S502-K5.8	\$ 356.00	CB10	14.39	S503-D50	\$ 600.00	CB10	14.38	S504UC-B40	\$ 908.00	CB10	14.40
S502-K8	\$ 356.00	CB10	14.39	S503-D63	\$ 646.00	CB10	14.38	S504UC-B50	\$ 1,030.00	CB10	14.40
S502-K0.8	\$ 356.00	CB10	14.39	S503-K0.15	\$ 518.00	CB10	14.39	S504UC-B6	\$ 908.00	CB10	14.40
S502UC-B10	\$ 442.00	CB10	14.40	S503-K0.21	\$ 518.00	CB10	14.39	S504UC-B63	\$ 1,164.00	CB10	14.40
S502UC-B13	\$ 442.00	CB10	14.40	S503-K0.3	\$ 518.00	CB10	14.39	S504UC-K0.15	\$ 996.00	CB10	14.41
S502UC-B16	\$ 442.00	CB10	14.40	S503-K0.42	\$ 518.00	CB10	14.39	S504UC-K0.21	\$ 996.00	CB10	14.41
S502UC-B20	\$ 442.00	CB10	14.40	S503-K0.58	\$ 518.00	CB10	14.39	S504UC-K0.3	\$ 996.00	CB10	14.41
S502UC-B25	\$ 442.00	CB10	14.40	S503-K0.8	\$ 518.00	CB10	14.39	S504UC-K0.42	\$ 996.00	CB10	14.41
S502UC-B32	\$ 442.00	CB10	14.40	S503-K1.1	\$ 518.00	CB10	14.39	S504UC-K0.58	\$ 996.00	CB10	14.41
S502UC-B40	\$ 442.00	CB10	14.40	S503-K1.5	\$ 518.00	CB10	14.39	S504UC-K0.8	\$ 996.00	CB10	14.41
S502UC-B50	\$ 502.00	CB10	14.40	S503-K11	\$ 518.00	CB10	14.39	S504UC-K1.1	\$ 996.00	CB10	14.41
S502UC-B6	\$ 442.00	CB10	14.40	S503-K15	\$ 518.00	CB10	14.39	S504UC-K1.5	\$ 996.00	CB10	14.41
S502UC-B63	\$ 568.00	CB10	14.40	S503-K2.1	\$ 518.00	CB10	14.39	S504UC-K11	\$ 996.00	CB10	14.41
S502UC-K0.15	\$ 488.00	CB10	14.41	S503-K20	\$ 518.00	CB10	14.39	S504UC-K15	\$ 996.00	CB10	14.41
S502UC-K0.21	\$ 488.00	CB10	14.41	S503-K26	\$ 518.00	CB10	14.39	S504UC-K2.1	\$ 996.00	CB10	14.41
S502UC-K0.3	\$ 488.00	CB10	14.41	S503-K3	\$ 518.00	CB10	14.39	S504UC-K20	\$ 996.00	CB10	14.41
S502UC-K0.42	\$ 488.00	CB10	14.41	S503-K32	\$ 574.00	CB10	14.39	S504UC-K26	\$ 996.00	CB10	14.41
S502UC-K0.58	\$ 488.00	CB10	14.41	S503-K37	\$ 574.00	CB10	14.39	S504UC-K3	\$ 996.00	CB10	14.41
S502UC-K0.8	\$ 488.00	CB10	14.41	S503-K4.2	\$ 518.00	CB10	14.39	S504UC-K32	\$ 1,142.00	CB10	14.41
S502UC-K1.1	\$ 488.00	CB10	14.41	S503-K41	\$ 644.00	CB10	14.39	S504UC-K37	\$ 1,142.00	CB10	14.41

S504UC-K4.2 – SC10M30NV2AO

Catalog number	List price	Discount schedule	Page number	Catalog number	List price	Discount schedule	Page number	Catalog number	List price	Discount schedule	Page number
S504UC-K4.2	\$ 996.00	CB10	14.41	S6H600DW	\$ 3,275.00	S6	15.46	S6N800MW	\$ 4,802.00	S6	15.46
S504UC-K41	\$ 1,276.00	CB10	14.41	S6H600EW	\$ 8,661.00	S6	15.44	S6N800MW-2	\$ 3,842.00	S6	15.46
S504UC-K45	\$ 1,276.00	CB10	14.41	S6H600MW	\$ 5,271.00	S6	15.46	S6N800TW	\$ 4,802.00	S6	15.44
S504UC-K5.8	\$ 996.00	CB10	14.41	S6H600MW-2	\$ 4,275.00	S6	15.46	S6N800TW-2	\$ 3,842.00	S6	15.44
S504UC-K8	\$ 996.00	CB10	14.41	S6H600TW	\$ 5,271.00	S6	15.44	S6NK800	\$ 350.00	SE	15.66
S5E-1	\$ 305.00	SE	15.66	S6H600TW-2	\$ 4,275.00	S6	15.44	S6NQ600BW	\$ 3,969.00	S6	15.45
S5E-3R12	\$ 575.00	SE	15.66	S6H800BW	\$ 6,465.00	S6	15.44	S6NQ600CW	\$ 5,498.00	S6	15.45
S5H300TW	\$ 3,654.00	S5	15.40	S6H800BW-2	\$ 5,275.00	S6	15.44	S6NQ600EW	\$ 7,698.00	S6	15.45
S5H300TW-2	\$ 3,285.00	S5	15.40	S6H800CW	\$ 7,855.00	S6	15.44	S6NQ800BW	\$ 5,282.00	S6	15.45
S5H400BW	\$ 3,654.00	S5	15.40	S6H800CW-2	\$ 6,665.00	S6	15.44	S6NQ800CW	\$ 6,811.00	S6	15.45
S5H400BW-2	\$ 3,285.00	S5	15.40	S6H800DW	\$ 4,248.00	S6	15.46	S6NQ800EW	\$ 9,011.00	S6	15.45
S5H400CW	\$ 4,320.00	S5	15.40	S6H800EW	\$ 9,855.00	S6	15.44	S7D1000W	\$ 7,300.00	S7	15.50
S5H400CW-2	\$ 3,951.00	S5	15.40	S6H800MW	\$ 6,465.00	S6	15.46	S7D1250W	\$ 7,300.00	S7	15.50
S5H400DW	\$ 1,994.00	S5	15.42	S6H800MW-2	\$ 5,270.00	S6	15.46	S7E-1	\$ 685.00	SE	15.66
S5H400EW	\$ 5,220.00	S5	15.40	S6H800TW	\$ 6,465.00	S6	15.44	S7E-3R12	\$ 905.00	SE	15.66
S5H400MW	\$ 3,654.00	S5	15.42	S6H800TW-2	\$ 5,275.00	S6	15.44	S7H1000BW	\$ 7,724.00	S7	15.48
S5H400MW-2	\$ 3,285.00	S5	15.42	S6HQ600BW	\$ 5,798.00	S6	15.45	S7H1000BW-2	\$ 6,959.00	S7	15.48
S5H400TW	\$ 3,654.00	S5	15.40	S6HQ600CW	\$ 7,327.00	S6	15.45	S7H1000CW	\$ 8,039.00	S7	15.48
S5H400TW-2	\$ 3,285.00	S5	15.40	S6HQ600EW	\$ 9,527.00	S6	15.45	S7H1000CW-2	\$ 8,039.00	S7	15.48
S5HQ400BW	\$ 4,019.00	S5	15.41	S6HQ800BW	\$ 7,112.00	S6	15.45	S7H1000DW	\$ 7,300.00	S7	15.50
S5HQ400CW	\$ 4,752.00	S5	15.41	S6HQ800CW	\$ 8,641.00	S6	15.45	S7H1000EW	\$ 10,604.00	S7	15.48
S5HQ400EW	\$ 5,742.00	S5	15.41	S6HQ800EW	\$ 10,841.00	S6	15.45	S7H1000MW	\$ 7,724.00	S7	15.50
S5L300TW	\$ 4,733.00	S5	15.40	S6L600BW	\$ 6,482.00	S6	15.44	S7H1000MW-2	\$ 6,959.00	S7	15.50
S5L300TW-2	\$ 3,945.00	S5	15.40	S6L600BW-2	\$ 5,481.00	S6	15.44	S7H1200BW	\$ 7,724.00	S7	15.48
S5L400BW	\$ 4,733.00	S5	15.40	S6L600CW	\$ 7,872.00	S6	15.44	S7H1200BW-2	\$ 6,959.00	S7	15.48
S5L400BW-2	\$ 3,945.00	S5	15.40	S6L600CW-2	\$ 6,871.00	S6	15.44	S7H1200CW	\$ 8,804.00	S7	15.48
S5L400CW	\$ 5,399.00	S5	15.40	S6L600EW	\$ 8,972.00	S6	15.44	S7H1200CW-2	\$ 8,039.00	S7	15.48
S5L400CW-2	\$ 4,611.00	S5	15.40	S6L600MW	\$ 6,482.00	S6	15.46	S7H1200DW	\$ 7,300.00	S7	15.50
S5L400EW	\$ 6,299.00	S5	15.40	S6L600MW-2	\$ 5,481.00	S6	15.46	S7H1200EW	\$ 10,604.00	S7	15.48
S5L400MW	\$ 4,733.00	S5	15.42	S6L600TW	\$ 6,482.00	S6	15.44	S7H1200MW	\$ 7,724.00	S7	15.50
S5L400MW-2	\$ 3,945.00	S5	15.42	S6L600TW-2	\$ 5,481.00	S6	15.44	S7H1200MW-2	\$ 6,959.00	S7	15.50
S5L400TW	\$ 4,733.00	S5	15.40	S6L800BW	\$ 7,676.00	S6	15.44	S7HQ1000BW	\$ 8,495.00	S7	15.49
S5L400TW-2	\$ 3,945.00	S5	15.40	S6L800BW-2	\$ 6,476.00	S6	15.44	S7HQ1000CW	\$ 9,684.00	S7	15.49
S5LQ400BW	\$ 5,206.00	S5	15.41	S6L800CW	\$ 9,066.00	S6	15.44	S7HQ1000EW	\$ 11,664.00	S7	15.49
S5LQ400CW	\$ 5,939.00	S5	15.41	S6L800CW-2	\$ 7,866.00	S6	15.44	S7HQ1200BW	\$ 8,495.00	S7	15.49
S5LQ400EW	\$ 6,929.00	S5	15.41	S6L800EW	\$ 11,066.00	S6	15.44	S7HQ1200CW	\$ 9,684.00	S7	15.49
S5N300TW	\$ 2,151.00	S5	15.40	S6L800MW	\$ 7,676.00	S6	15.46	S7HQ1200EW	\$ 11,664.00	S7	15.49
S5N300TW-2	\$ 1,798.00	S5	15.40	S6L800MW-2	\$ 6,476.00	S6	15.46	S7NK1200	\$ 535.00	SE	15.66
S5N400BW	\$ 2,151.00	S5	15.40	S6L800TW	\$ 7,676.00	S6	15.44	S8ES250-1	\$ 5,285.00	SE	15.66
S5N400BW-2	\$ 1,798.00	S5	15.40	S6L800TW-2	\$ 6,476.00	S6	15.44	S8ES250-3R12	\$ 5,285.00	SE	15.66
S5N400CW	\$ 2,817.00	S5	15.40	S6LQ600BW	\$ 7,130.00	S6	15.45	S8V16CW	\$ 12,540.00	S8	15.52
S5N400CW-2	\$ 2,464.00	S5	15.40	S6LQ600CW	\$ 8,659.00	S6	15.45	S8V16DW	\$ 9,620.00	S8	15.52
S5N400EW	\$ 3,717.00	S5	15.40	S6LQ600EW	\$ 9,869.00	S6	15.45	S8V16EW	\$ 14,505.00	S8	15.52
S5N400MW	\$ 2,151.00	S5	15.42	S6LQ800BW	\$ 8,444.00	S6	15.45	S8V16MW	\$ 11,267.00	S8	15.52
S5N400MW-2	\$ 1,798.00	S5	15.42	S6LQ800CW	\$ 9,973.00	S6	15.45	S8V20CW	\$ 14,427.00	S8	15.52
S5N400TW	\$ 2,151.00	S5	15.40	S6LQ800EW	\$ 12,173.00	S6	15.45	S8V20DW	\$ 10,999.00	S8	15.52
S5N400TW-2	\$ 1,798.00	S5	15.40	S6N600BW	\$ 3,608.00	S6	15.44	S8V20EW	\$ 16,561.00	S8	15.52
S5NK400	\$ 260.00	SE	15.66	S6N600BW-2	\$ 2,847.00	S6	15.44	S8V20MW	\$ 12,988.00	S8	15.52
S5NQ400BW	\$ 2,366.00	S5	15.41	S6N600CW	\$ 4,998.00	S6	15.44	S8V25CW	\$ 21,561.00	S8	15.52
S5NQ400CW	\$ 3,099.00	S5	15.41	S6N600CW-2	\$ 4,237.00	S6	15.44	S8V25DW	\$ 16,267.00	S8	15.52
S5NQ400EW	\$ 4,089.00	S5	15.41	S6N600EW	\$ 6,998.00	S6	15.44	S8V25EW	\$ 24,487.00	S8	15.52
S6D400W	\$ 3,275.00	S6	15.46	S6N600MW	\$ 3,608.00	S6	15.46	S8V25MW	\$ 20,916.00	S8	15.52
S6D630W	\$ 3,275.00	S6	15.46	S6N600MW-2	\$ 2,847.00	S6	15.46	S8VQ16CW	\$ 13,168.00	S8	15.52
S6D800W	\$ 4,248.00	S6	15.46	S6N600TW	\$ 3,608.00	S6	15.44	S8VQ16EW	\$ 15,231.00	S8	15.52
S6E-1	\$ 685.00	SE	15.66	S6N600TW-2	\$ 2,847.00	S6	15.44	S8VQ20CW	\$ 15,148.00	S8	15.52
S6E-3R12	\$ 905.00	SE	15.66	S6N800BW	\$ 4,802.00	S6	15.44	S8VQ20EW	\$ 17,390.00	S8	15.52
S6H600BW	\$ 5,271.00	S6	15.44	S6N800BW-2	\$ 3,842.00	S6	15.44	SA1	\$ 9.00	CB8	14.19
S6H600BW-2	\$ 4,275.00	S6	15.44	S6N800CW	\$ 6,192.00	S6	15.44	SA2	\$ 19.00	CB8	14.19
S6H600CW	\$ 6,661.00	S6	15.44	S6N800CW-2	\$ 5,232.00	S6	15.44	SA450	\$ 30.00	MA	5.18
S6H600CW-2	\$ 5,665.00	S6	15.44	S6N800EW	\$ 8,192.00	S6	15.44	SC10M30NV2AO	\$ 265.00	RP	10.82

SCF10M30NC1PO – SOLXM18NC1PO

Alphanumeric

0

Catalog number	List price	Discount schedule	Page number	Catalog number	List price	Discount schedule	Page number	Catalog number	List price	Discount schedule	Page number
SCF10M30NC1PO	\$ 225.00	RP	10.81	SIF2M12NV2DO	\$ 70.00	RP	10.23	SIN40Q55UTAK	\$ 210.00	RP	10.22
SCF10M30NV2AO	\$ 265.00	RP	10.82	SIF2M12NV2NK	\$ 82.00	RP	10.63	SIN40Q55UTAK4	\$ 310.00	RP	10.72
SCF10M30NV2PO	\$ 220.00	RP	10.81	SIF2M12NV2NO	\$ 72.00	RP	10.38	SIN40Q55UTPK	\$ 120.00	RP	10.69
SD-PZ1	\$ 40.00	CB8	14.20	SIF2M12NV2PK	\$ 82.00	RP	10.63	SIN4M12EC1DO	\$ 73.00	RP	10.25
SD-PZ2	\$ 40.00	CB8	14.20	SIF2M12NV2PO	\$ 72.00	RP	10.38	SIN4M12EC1NO	\$ 60.00	RP	10.46
SIF0.8Z4NC8PO	\$ 111.00	RP	10.31	SIF2M12SC1PO	\$ 76.00	RP	10.39	SIN4M12EC1PO	\$ 60.00	RP	10.46
SIF0.8Z4NU2PO	\$ 107.00	RP	10.31	SIF2M12SU2PO	\$ 81.00	RP	10.38	SIN4M12EV2AC	\$ 101.00	RP	10.13
SIF1.5M8EC1NO	\$ 68.00	RP	10.33	SIF2M12WC1PO	\$ 70.00	RP	10.73	SIN4M12NC1NO	\$ 76.00	RP	10.45
SIF1.5M8EC1PO	\$ 68.00	RP	10.33	SIF40Q80UTPK	\$ 225.00	RP	10.70	SIN4M12NC1PO	\$ 76.00	RP	10.45
SIF1.5M8NV2NO	\$ 76.00	RP	10.34	SIF5M18EC1DO	\$ 73.00	RP	10.27	SIN4M12NC2AO	\$ 103.00	RP	10.13
SIF1.5M8NV2PO	\$ 76.00	RP	10.34	SIF5M18EC1NO	\$ 63.00	RP	10.48	SIN4M12NV2DO	\$ 70.00	RP	10.26
SIF1.5M8SC1NO	\$ 80.00	RP	10.36	SIF5M18EC1PO	\$ 63.00	RP	10.48	SIN4M12NV2NK	\$ 83.00	RP	10.63
SIF1.5M8SC1PO	\$ 80.00	RP	10.36	SIF5M18NC1NO	\$ 84.00	RP	10.47	SIN4M12NV2NO	\$ 72.00	RP	10.44
SIF1.5M8SU2PO	\$ 85.00	RP	10.34	SIF5M18NC1PO	\$ 84.00	RP	10.47	SIN4M12NV2PK	\$ 83.00	RP	10.63
SIF1.5MBNV2DO	\$ 80.00	RP	10.23	SIF5M18NC2AO	\$ 103.00	RP	10.14	SIN4M12NV2PO	\$ 72.00	RP	10.44
SIF1.5Z6NC8PO	\$ 82.00	RP	10.32	SIF5M18NC7AC	\$ 103.00	RP	10.15	SIN4M12SC1PO	\$ 76.00	RP	10.45
SIF1.5Z6NU2PO	\$ 80.00	RP	10.32	SIF5M18NC7AO	\$ 103.00	RP	10.15	SIN4M12SU2PO	\$ 81.00	RP	10.44
SIF10M30EC1DO	\$ 95.00	RP	10.29	SIF5M18NV2AC	\$ 101.00	RP	10.14	SIN4M12WC1PO	\$ 70.00	RP	10.74
SIF10M30EC1PO	\$ 79.00	RP	10.54	SIF5M18NV2AO	\$ 101.00	RP	10.14	SIN50Q80UTPK	\$ 210.00	RP	10.70
SIF10M30NC1NO	\$ 88.00	RP	10.53	SIF5M18NV2DO	\$ 84.00	RP	10.26	SIN50Q80UTPO	\$ 210.00	RP	10.62
SIF10M30NC1PO	\$ 88.00	RP	10.53	SIF5M18NV2NK	\$ 84.00	RP	10.64	SIN6M12NC1PO	\$ 124.00	RP	10.49
SIF10M30NC2AO	\$ 110.00	RP	10.17	SIF5M18NV2NO	\$ 82.00	RP	10.47	SIN6M12NV2PO	\$ 118.00	RP	10.49
SIF10M30NC7AC	\$ 112.00	RP	10.17	SIF5M18NV2PK	\$ 84.00	RP	10.64	SIN8M18EC1DO	\$ 75.00	RP	10.28
SIF10M30NC7AO	\$ 112.00	RP	10.17	SIF5M18NV2PO	\$ 82.00	RP	10.47	SIN8M18EC1PO	\$ 63.00	RP	10.52
SIF10M30NV2AC	\$ 108.00	RP	10.16	SIF6B45NV2PO	\$ 120.00	RP	10.50	SIN8M18NC1NO	\$ 84.00	RP	10.51
SIF10M30NV2AO	\$ 108.00	RP	10.16	SIN12M18NC1PO	\$ 111.00	RP	10.55	SIN8M18NC1PO	\$ 84.00	RP	10.51
SIF10M30NV2DO	\$ 84.00	RP	10.29	SIN12M18NV2PO	\$ 109.00	RP	10.55	SIN8M18NC7AC	\$ 111.00	RP	10.16
SIF10M30NV2NK	\$ 92.00	RP	10.65	SIN15M30EC1DO	\$ 95.00	RP	10.30	SIN8M18NC7AO	\$ 111.00	RP	10.16
SIF10M30NV2NO	\$ 86.00	RP	10.53	SIN15M30EC1PO	\$ 79.00	RP	10.57	SIN8M18NV2AC	\$ 108.00	RP	10.15
SIF10M30NV2PK	\$ 92.00	RP	10.65	SIN15M30NC1NO	\$ 84.00	RP	10.56	SIN8M18NV2AO	\$ 108.00	RP	10.15
SIF10M30NV2PO	\$ 86.00	RP	10.53	SIN15M30NC1PO	\$ 84.00	RP	10.56	SIN8M18NV2DO	\$ 84.00	RP	10.28
SIF10M30WC1PO	\$ 100.00	RP	10.77	SIN15M30NC2AO	\$ 110.00	RP	10.18	SIN8M18NV2NK	\$ 85.00	RP	10.64
SIF15Q40NC1PO	\$ 116.00	RP	10.58	SIN15M30NC7AO	\$ 112.00	RP	10.19	SIN8M18NV2NO	\$ 82.00	RP	10.51
SIF15Q40UTAK	\$ 135.00	RP	10.20	SIN15M30NV2AC	\$ 108.00	RP	10.18	SIN8M18NV2PK	\$ 85.00	RP	10.64
SIF15Q40UTNK	\$ 136.00	RP	10.66	SIN15M30NV2AO	\$ 108.00	RP	10.18	SIN8M18NV2PO	\$ 82.00	RP	10.51
SIF15Q40UTNO	\$ 135.00	RP	10.58	SIN15M30NV2DO	\$ 84.00	RP	10.30	SIN8M18WC1PO	\$ 110.00	RP	10.76
SIF15Q40UTPK	\$ 136.00	RP	10.66	SIN15M30NV2NK	\$ 94.00	RP	10.65	SK1-02	\$ 33.00	MA	5.4
SIF15Q40UTPO	\$ 135.00	RP	10.58	SIN15M30NV2NO	\$ 80.00	RP	10.56	SK1-11	\$ 33.00	MA	5.4
SIF15Q40WTAO	\$ 280.00	RP	10.80	SIN15M30NV2PK	\$ 94.00	RP	10.65	SK1-20	\$ 33.00	MA	5.4
SIF15Q40WTPO	\$ 190.00	RP	10.79	SIN15M30NV2PO	\$ 80.00	RP	10.56	SK4-11	\$ 60.00	MA	5.18
SIF20Q40NC1PO	\$ 114.00	RP	10.59	SIN15M30WC1PO	\$ 100.00	RP	10.78	SLTH31	\$ 15.00	RM	9.22
SIF20Q40SC1PO	\$ 114.00	RP	10.60	SIN15Q30UC7AC	\$ 123.00	RP	10.19	SMR-39	\$ 21.00	CB8	14.19
SIF20Q40TC1PK	\$ 114.00	RP	10.67	SIN15Q30UC7AO	\$ 123.00	RP	10.19	SOD20000B75NTKK	\$ 125.00	RO	10.93
SIF20Q40TC1PO	\$ 114.00	RP	10.60	SIN20Q40UTAK	\$ 135.00	RP	10.20	SOD2000B75NTKK	\$ 125.00	RO	10.93
SIF20Q40UTNK	\$ 120.00	RP	10.66	SIN20Q40UTAK4	\$ 260.00	RP	10.71	SOD200M18NC1PO	\$ 82.00	RO	10.89
SIF20Q40UTPK	\$ 120.00	RP	10.66	SIN2M8EC1PO	\$ 68.00	RP	10.35	SOD400B26NU2PO	\$ 129.00	RO	10.90
SIF20Q40UTPO	\$ 109.00	RP	10.59	SIN2M8NC1NO	\$ 80.00	RP	10.37	SOD500B45NC1NKS	\$ 155.00	RO	10.91
SIF2B28NV0.1NC	\$ 109.00	RP	10.40	SIN2M8NC1PO	\$ 80.00	RP	10.37	SOD500B45NC1PKS	\$ 155.00	RO	10.91
SIF2B28NV0.1NO	\$ 109.00	RP	10.40	SIN2M8NV2NO	\$ 76.00	RP	10.36	SOD800B75NTPOS	\$ 107.00	RO	10.92
SIF2B28NV0.1PC	\$ 109.00	RP	10.40	SIN2M8NV2PO	\$ 76.00	RP	10.36	SOLD100M18NGVM8	\$ 74.00	RO	10.105
SIF2B28NV0.1PO	\$ 109.00	RP	10.40	SIN2M8SU2PO	\$ 85.00	RP	10.37	SOLD15B50NPVM3	\$ 89.00	RO	10.107
SIF2M12EC1DO	\$ 73.00	RP	10.24	SIN30Q40SC1PO	\$ 114.00	RP	10.61	SOLD45M18NGMM8	\$ 96.00	RO	10.105
SIF2M12EC1NO	\$ 60.00	RP	10.42	SIN30Q40TC1PK	\$ 124.00	RP	10.68	SOLD50B50NPVM6	\$ 53.00	RO	10.107
SIF2M12EC1PO	\$ 60.00	RP	10.42	SIN30Q40UC7AK	\$ 127.00	RP	10.21	SOLT150B50NPVM3	\$ 65.00	RO	10.108
SIF2M12EV2AC	\$ 101.00	RP	10.11	SIN30Q40UTNK	\$ 124.00	RP	10.68	SOLT150B50NPVM4	\$ 57.00	RO	10.108
SIF2M12NC1NO	\$ 76.00	RP	10.39	SIN30Q40UTNO	\$ 112.00	RP	10.61	SOLT700M18NGMM8	\$ 126.00	RO	10.106
SIF2M12NC1PC	\$ 76.00	RP	10.41	SIN30Q40UTPK	\$ 124.00	RP	10.68	SOLT700M18NGVM8	\$ 106.00	RO	10.106
SIF2M12NC1PO	\$ 76.00	RP	10.39	SIN30Q40UTPO	\$ 112.00	RP	10.61	SOLT700M1NGMM8	\$ 126.00	RO	10.106
SIF2M12NC2AO	\$ 103.00	RP	10.12	SIN3M8NC8PO	\$ 128.00	RP	10.43	SOLXB50NU2POS	\$ 163.00	RO	10.103
SIF2M12NV2AO	\$ 101.00	RP	10.12	SIN3M8NV2PO	\$ 125.00	RP	10.43	SOLXM18NC1PO	\$ 129.00	RO	10.102

SOR1500M18NC1PO – T060L1-48

Catalog number	List price	Discount schedule	Page number	Catalog number	List price	Discount schedule	Page number	Catalog number	List price	Discount schedule	Page number
SOR1500M18NC1PO	\$ 82.00	RO	10.94	SZ-BSK5	\$ 4.00	CB8	14.17	T025LF1-48B	\$ 2,110.00	PSTE	6.28
SOR2000B15NI2PO	\$ 129.00	RO	10.95	SZ-ESK1	\$ 10.00	CB8	14.17	T025LF1-60B	\$ 2,065.00	PSTE	6.28
SOR2000B26NU2PO	\$ 129.00	RO	10.95	SZ-ESK2	\$ 10.00	CB8	14.17	T030D1-48	\$ 1,655.00	PSTE	6.27
SOR3000M18NC1PO	\$ 82.00	RO	10.96	SZ-KS1/12	\$ 12.00	CB8	14.15	T030D1-60	\$ 1,655.00	PSTE	6.27
SOR5000B75NTKK	\$ 125.00	RO	10.97	SZ-KS1/56	\$ 36.00	CB8	14.15	T030D2-48M	\$ 1,930.00	PSTE	6.27
SOR5000B75NTPOS	\$ 107.00	RO	10.97	SZ-KS16/12N	\$ 13.00	CB8	14.17	T030D2-60M	\$ 1,905.00	PSTE	6.27
SOR6000B45NC1NKS	\$ 155.00	RO	10.99	SZ-KS16/56N	\$ 55.00	CB8	14.17	T030DB1-48L	\$ 2,255.00	PSTE	6.29
SOR6000B45NC1PKS	\$ 155.00	RO	10.99	SZ-KS2/56	\$ 46.00	CB8	14.15	T030DB1-60K	\$ 2,080.00	PSTE	6.29
SORG2000B45NC1NKS	\$ 195.00	RO	10.98	SZ-KS3/39N	\$ 50.00	CB8	14.16	T030DF1-48C	\$ 2,255.00	PSTE	6.29
SORG2000B45NC1PKS	\$ 195.00	RO	10.98	SZ-KS4/39N	\$ 56.00	CB8	14.16	T030DF1-60B	\$ 2,080.00	PSTE	6.29
SOT15MB45NC1NKS	\$ 215.00	RO	10.100	SZ-PSB12N	\$ 176.00	CB8	14.15	T030L1-48	\$ 1,715.00	PSTE	6.26
SOT15MB45NC1PKS	\$ 215.00	RO	10.100	SZ-PSB23N	\$ 50.00	CB8	14.17	T030L1-60	\$ 1,685.00	PSTE	6.26
SOT20MB75NTKK	\$ 225.00	RO	10.101	SZ-PSB24N	\$ 176.00	CB8	14.17	T030L2-48M	\$ 2,165.00	PSTE	6.26
SSM-138300-E	-	SSME	6.51	SZ-PSB46N	\$ 124.00	CB8	14.16	T030L2-60M	\$ 2,085.00	PSTE	6.26
SSM-138300-E-S	-	SSME	6.51	SZ-PSB48N	\$ 158.00	CB8	14.16	T030LB1-48L	\$ 2,315.00	PSTE	6.28
SSM-138600-E	-	SSME	6.51	SZ-PSB4N	\$ 130.00	CB8	14.15	T030LB1-60K	\$ 2,110.00	PSTE	6.28
SSM-138600-E-S	-	SSME	6.51	SZ-PSB50N	\$ 124.00	CB8	14.16	T030LF1-48C	\$ 2,315.00	PSTE	6.28
SSM-23200-E	-	SSME	6.51	SZ-PSB52N	\$ 158.00	CB8	14.16	T030LF1-60B	\$ 2,110.00	PSTE	6.28
SSM-23200-E-S	-	SSME	6.51	SZ-PSB54N	\$ 122.00	CB8	14.15	T040D1-48	\$ 1,685.00	PSTE	6.27
SSM-23400-E	-	SSME	6.51	SZ-PSB56N	\$ 122.00	CB8	14.15	T040D1-60	\$ 1,655.00	PSTE	6.27
SSM-23400-E-S	-	SSME	6.51	SZ-PSB58N	\$ 198.00	CB8	14.17	T040D2-48M	\$ 2,085.00	PSTE	6.27
SSM-23600-E	-	SSME	6.51	SZ-PSB60N	\$ 238.00	CB8	14.17	T040D2-60M	\$ 1,930.00	PSTE	6.27
SSM-23600-E-S	-	SSME	6.51	SZ-PSB62N	\$ 204.00	CB8	14.15	T040DB1-48N	\$ 2,285.00	PSTE	6.29
SSM-33200-E	-	SSME	6.51	SZ-PSB64N	\$ 236.00	CB8	14.15	T040DB1-60L	\$ 2,255.00	PSTE	6.29
SSM-33200-E-S	-	SSME	6.51	SZ-PSB92N	\$ 174.00	CB8	14.16	T040DF1-48C	\$ 2,285.00	PSTE	6.29
SSM-33400-E	-	SSME	6.51	SZ-VB45.32	\$ 68.00	CB8	14.15	T040DF1-60C	\$ 2,255.00	PSTE	6.29
SSM-33400-E-S	-	SSME	6.51	T-10	\$ 7,700.00	G	13.6	T040L1-48	\$ 2,055.00	PSTE	6.26
SSM-33600-E	-	SSME	6.51	T-20	\$ 4,112.50	G	13.6	T040L1-60	\$ 1,715.00	PSTE	6.26
SSM-33600-E-S	-	SSME	6.51	T-30	\$ 2,550.00	G	13.6	T040L2-48M	\$ 2,555.00	PSTE	6.26
SSM-41200-E	-	SSME	6.51	T-40	\$ 1,450.00	G	13.6	T040L2-60M	\$ 2,165.00	PSTE	6.26
SSM-41200-E-S	-	SSME	6.51	T010L1-48	\$ 1,655.00	PSTE	6.26	T040LB1-48N	\$ 2,655.00	PSTE	6.28
SSM-41400-E	-	SSME	6.51	T010L2-48M	\$ 1,905.00	PSTE	6.26	T040LB1-60L	\$ 2,315.00	PSTE	6.28
SSM-41400-E-S	-	SSME	6.51	T010LB1-48E	\$ 2,055.00	PSTE	6.28	T040LF1-48C	\$ 2,655.00	PSTE	6.28
SSM-41600-E	-	SSME	6.51	T010LF1-48A	\$ 2,055.00	PSTE	6.28	T040LF1-60C	\$ 2,315.00	PSTE	6.28
SSM-41600-E-S	-	SSME	6.51	T015L1-60	\$ 1,655.00	PSTE	6.26	T050D1-48	\$ 1,715.00	PSTE	6.27
SSM-66200-E	-	SSME	6.51	T015L2-60M	\$ 1,905.00	PSTE	6.26	T050D1-60	\$ 1,685.00	PSTE	6.27
SSM-66200-E-S	-	SSME	6.51	T015LB1-60E	\$ 2,055.00	PSTE	6.28	T050D2-48M	\$ 2,165.00	PSTE	6.27
SSM-66400-E	-	SSME	6.51	T015LF1-60A	\$ 2,055.00	PSTE	6.28	T050D2-60M	\$ 2,085.00	PSTE	6.27
SSM-66400-E-S	-	SSME	6.51	T020D1-48	\$ 1,655.00	PSTE	6.27	T050DB1-48R	\$ 2,315.00	PSTE	6.29
SSM-66600-E	-	SSME	6.51	T020D2-48M	\$ 1,905.00	PSTE	6.27	T050DB1-60N	\$ 2,285.00	PSTE	6.29
SSM-66600-E-S	-	SSME	6.51	T020DB1-48J	\$ 2,065.00	PSTE	6.29	T050DF1-48C	\$ 2,315.00	PSTE	6.29
ST-E	\$ 12.00	CB8	17.13	T020DF1-48B	\$ 2,065.00	PSTE	6.29	T050DF1-60C	\$ 2,285.00	PSTE	6.29
ST1	\$ 140.00	RA	10.122	T020L1-48	\$ 1,655.00	PSTE	6.26	T050L1-48	\$ 2,080.00	PSTE	6.26
STL-ST	\$ 74.00	CB8	14.19	T020L2-48M	\$ 1,930.00	PSTE	6.26	T050L1-60	\$ 2,055.00	PSTE	6.26
SUD.5KM30NC1M	\$ 730.00	RU	10.115	T020LB1-48J	\$ 2,065.00	PSTE	6.28	T050L2-48M	\$ 2,630.00	PSTE	6.26
SUD.5KM30NC1NOS	\$ 422.00	RU	10.112	T020LF1-48B	\$ 2,065.00	PSTE	6.28	T050L2-60M	\$ 2,555.00	PSTE	6.26
SUD.5KM30NC1POS	\$ 422.00	RU	10.112	T025D1-48	\$ 1,655.00	PSTE	6.27	T050LB1-48R	\$ 2,680.00	PSTE	6.28
SUD2KM30NC1M	\$ 740.00	RU	10.115	T025D1-60	\$ 1,655.00	PSTE	6.27	T050LB1-60N	\$ 2,655.00	PSTE	6.28
SUD2KM30NC1NOS	\$ 430.00	RU	10.112	T025D2-48M	\$ 1,905.00	PSTE	6.27	T050LF1-48C	\$ 2,680.00	PSTE	6.28
SUD2KM30NC1POS	\$ 430.00	RU	10.112	T025D2-60M	\$ 1,905.00	PSTE	6.27	T050LF1-60C	\$ 2,655.00	PSTE	6.28
SUD4KM30NC1M	\$ 760.00	RU	10.116	T025DB1-48K	\$ 2,080.00	PSTE	6.29	T060D1-48	\$ 2,055.00	PSTE	6.27
SUD4KM30NC1NOS	\$ 450.00	RU	10.113	T025DB1-60J	\$ 2,065.00	PSTE	6.29	T060D1-60	\$ 1,715.00	PSTE	6.27
SUD4KM30NC1POS	\$ 450.00	RU	10.113	T025DF1-48B	\$ 2,080.00	PSTE	6.29	T060D2-48M	\$ 2,555.00	PSTE	6.27
SUD6KM30NC1M	\$ 840.00	RU	10.116	T025DF1-60B	\$ 2,065.00	PSTE	6.29	T060D2-60M	\$ 2,165.00	PSTE	6.27
SUD6KM30NC1NOS	\$ 470.00	RU	10.113	T025L1-48	\$ 1,685.00	PSTE	6.26	T060DB1-48S	\$ 3,055.00	PSTE	6.29
SUD6KM30NC1POS	\$ 470.00	RU	10.113	T025L1-60	\$ 1,655.00	PSTE	6.26	T060DB1-60R	\$ 2,315.00	PSTE	6.29
SZ-AS71	\$ 10.00	CB8	14.20	T025L2-48M	\$ 2,085.00	PSTE	6.26	T060DF1-48D	\$ 3,055.00	PSTE	6.29
SZ-AS78	\$ 10.00	CB8	14.20	T025L2-60M	\$ 1,930.00	PSTE	6.26	T060DF1-60C	\$ 2,315.00	PSTE	6.29
SZ-AST121	\$ 15.00	CB8	14.20	T025LB1-48K	\$ 2,110.00	PSTE	6.28	T060FL1-60C	\$ 2,680.00	PSTE	6.28
SZ-AST501	\$ 15.00	CB8	14.20	T025LB1-60J	\$ 2,065.00	PSTE	6.28	T060L1-48	\$ 2,705.00	PSTE	6.26

T060L1-60 – T2H060TW-2

Alphanumeric

0

Catalog number	List price	Discount schedule	Page number	Catalog number	List price	Discount schedule	Page number	Catalog number	List price	Discount schedule	Page number
T060L1-60	\$ 2,080.00	PSTE	6.26	T125D2-48M	\$ 3,460.00	PSTE	6.27	T1N070TL	\$ 479.00	S1T	15.133
T060L2-48M	\$ 3,355.00	PSTE	6.26	T125D2-60M	\$ 3,355.00	PSTE	6.27	T1N080TL	\$ 479.00	S1T	15.133
T060L2-60M	\$ 2,630.00	PSTE	6.26	T125DB1-48X	\$ 4,535.00	PSTE	6.29	T1N090TL	\$ 479.00	S1T	15.133
T060LB1-48S	\$ 3,705.00	PSTE	6.28	T125DB1-60V	\$ 3,905.00	PSTE	6.29	T1N100DL	\$ 431.00	S1T	15.133
T060LB1-60R	\$ 2,680.00	PSTE	6.28	T125DF1-48E	\$ 4,535.00	PSTE	6.29	T1N100TL	\$ 479.00	S1T	15.133
T060LF1-48D	\$ 3,705.00	PSTE	6.28	T125DF1-60D	\$ 3,905.00	PSTE	6.29	T200D1-48	\$ 3,920.00	PSTE	6.27
T075D1-48	\$ 2,080.00	PSTE	6.27	T125L1-48	\$ 3,920.00	PSTE	6.26	T200D1-60	\$ 3,875.00	PSTE	6.27
T075D1-60	\$ 2,055.00	PSTE	6.27	T125L1-60	\$ 3,875.00	PSTE	6.26	T200D2-48M	\$ 5,120.00	PSTE	6.27
T075D2-48M	\$ 2,630.00	PSTE	6.27	T125L2-48M	\$ 5,120.00	PSTE	6.26	T200D2-60M	\$ 4,775.00	PSTE	6.27
T075D2-60M	\$ 2,555.00	PSTE	6.27	T125L2-60M	\$ 4,775.00	PSTE	6.26	T200DB1-48Z	\$ 5,720.00	PSTE	6.29
T075DB1-48T	\$ 3,080.00	PSTE	6.29	T125LB1-48X	\$ 5,720.00	PSTE	6.28	T200DB1-60Y	\$ 5,675.00	PSTE	6.29
T075DB1-60S	\$ 3,055.00	PSTE	6.29	T125LB1-60V	\$ 5,075.00	PSTE	6.28	T200DF1-48E	\$ 5,720.00	PSTE	6.29
T075DF1-48D	\$ 3,080.00	PSTE	6.29	T125LF1-48E	\$ 5,720.00	PSTE	6.28	T200DF1-60E	\$ 5,675.00	PSTE	6.29
T075DF1-60D	\$ 3,055.00	PSTE	6.29	T125LF1-60D	\$ 5,075.00	PSTE	6.28	T200L1-48	\$ 4,850.00	PSTE	6.26
T075L1-48	\$ 2,735.00	PSTE	6.26	T1500D1-48M	\$ 21,000.00	PSTE	6.27	T200L1-60	\$ 4,370.00	PSTE	6.26
T075L1-60	\$ 2,705.00	PSTE	6.26	T1500D1-60M	\$ 12,900.00	PSTE	6.27	T200L2-48M	\$ 6,550.00	PSTE	6.26
T075L2-48M	\$ 3,460.00	PSTE	6.26	T1500D2-48M	\$ 22,750.00	PSTE	6.27	T200L2-60M	\$ 5,770.00	PSTE	6.26
T075L2-60M	\$ 3,355.00	PSTE	6.26	T1500D2-60M	\$ 14,650.00	PSTE	6.27	T200LB1-48Z	\$ 6,650.00	PSTE	6.28
T075LB1-48T	\$ 3,735.00	PSTE	6.28	T1500DB1-48NM	\$ 33,500.00	PSTE	6.29	T200LB1-60Y	\$ 6,170.00	PSTE	6.28
T075LB1-60S	\$ 3,705.00	PSTE	6.28	T1500DB1-60MM	\$ 22,900.00	PSTE	6.29	T200LF1-48E	\$ 6,650.00	PSTE	6.28
T075LF1-48D	\$ 3,735.00	PSTE	6.28	T1500DF1-48NM	\$ 33,500.00	PSTE	6.29	T200LF1-60E	\$ 6,170.00	PSTE	6.28
T075LF1-60D	\$ 3,705.00	PSTE	6.28	T1500DF1-60LM	\$ 22,900.00	PSTE	6.29	T250D1-48	\$ 4,370.00	PSTE	6.27
T1000D1-48M	\$ 10,830.00	PSTE	6.27	T150D1-48	\$ 3,875.00	PSTE	6.27	T250D1-60	\$ 3,920.00	PSTE	6.27
T1000D1-60M	\$ 10,830.00	PSTE	6.27	T150D1-60	\$ 2,735.00	PSTE	6.27	T250D2-48M	\$ 5,770.00	PSTE	6.27
T1000D2-48M	\$ 12,130.00	PSTE	6.27	T150D2-48M	\$ 4,775.00	PSTE	6.27	T250D2-60M	\$ 5,120.00	PSTE	6.27
T1000D2-60M	\$ 12,130.00	PSTE	6.27	T150D2-60M	\$ 3,460.00	PSTE	6.27	T250DB1-48B	\$ 6,870.00	PSTE	6.29
T1000DB1-48LM	\$ 20,830.00	PSTE	6.29	T150DB1-48Y	\$ 5,675.00	PSTE	6.29	T250DB1-60Z	\$ 5,720.00	PSTE	6.29
T1000DB1-60KM	\$ 18,030.00	PSTE	6.29	T150DB1-60X	\$ 4,535.00	PSTE	6.29	T250DF1-48F	\$ 6,870.00	PSTE	6.29
T1000DF1-48KM	\$ 20,830.00	PSTE	6.29	T150DF1-48E	\$ 5,675.00	PSTE	6.29	T250DF1-60E	\$ 5,720.00	PSTE	6.29
T1000DF1-60KM	\$ 18,030.00	PSTE	6.29	T150DF1-60E	\$ 4,535.00	PSTE	6.29	T250L1-48	\$ 5,080.00	PSTE	6.26
T1000L1-60M	\$ 21,000.00	PSTE	6.26	T150L1-48	\$ 4,370.00	PSTE	6.26	T250L1-60	\$ 4,850.00	PSTE	6.26
T1000L2-60M	\$ 22,300.00	PSTE	6.26	T150L1-60	\$ 3,920.00	PSTE	6.26	T250L2-48M	\$ 7,830.00	PSTE	6.26
T1000LB1-60KM	\$ 28,200.00	PSTE	6.28	T150L2-48M	\$ 5,770.00	PSTE	6.26	T250L2-60M	\$ 6,550.00	PSTE	6.26
T1000LF1-60KB	\$ 28,200.00	PSTE	6.28	T150L2-60M	\$ 5,120.00	PSTE	6.26	T250LB1-48B	\$ 7,580.00	PSTE	6.28
T100D1-48	\$ 2,705.00	PSTE	6.27	T150LB1-48Y	\$ 6,170.00	PSTE	6.28	T250LB1-60Z	\$ 6,650.00	PSTE	6.28
T100D1-60	\$ 2,080.00	PSTE	6.27	T150LB1-60X	\$ 5,720.00	PSTE	6.28	T250LF1-48F	\$ 7,580.00	PSTE	6.28
T100D2-48M	\$ 3,355.00	PSTE	6.27	T150LF1-48E	\$ 6,170.00	PSTE	6.28	T250LF1-60E	\$ 6,650.00	PSTE	6.28
T100D2-60M	\$ 2,630.00	PSTE	6.27	T150LF1-60E	\$ 5,720.00	PSTE	6.28	T2H010BW-2	-	S2T	15.135
T100DB1-48V	\$ 3,905.00	PSTE	6.29	T1800D1-60M	\$ 21,000.00	PSTE	6.27	T2H015TW	\$ 785.00	S2T	15.135
T100DB1-60T	\$ 3,080.00	PSTE	6.29	T1800D2-60M	\$ 22,750.00	PSTE	6.27	T2H015TW-2	-	S2T	15.135
T100DF1-48D	\$ 3,905.00	PSTE	6.29	T1800DB1-60NM	\$ 33,500.00	PSTE	6.29	T2H020MW	\$ 561.00	S2T	15.135
T100DF1-60D	\$ 3,080.00	PSTE	6.29	T1800DF1-60NM	\$ 33,500.00	PSTE	6.29	T2H020TW	\$ 785.00	S2T	15.135
T100FL1-60D	\$ 3,735.00	PSTE	6.28	T1B015TL-1	\$ 230.00	S1T	15.133	T2H020TW-2	-	S2T	15.135
T100L1-48	\$ 3,875.00	PSTE	6.26	T1B020TL-1	\$ 230.00	S1T	15.133	T2H025BW	\$ 1,243.00	S2T	15.135
T100L1-60	\$ 2,735.00	PSTE	6.26	T1B025TL-1	\$ 230.00	S1T	15.133	T2H025BW-2	-	S2T	15.135
T100L2-48M	\$ 4,775.00	PSTE	6.26	T1B030TL-1	\$ 230.00	S1T	15.133	T2H025E5W	-	S2T	15.135
T100L2-60M	\$ 3,460.00	PSTE	6.26	T1B040TL-1	\$ 230.00	S1T	15.133	T2H025TW	\$ 785.00	S2T	15.135
T100LB1-48V	\$ 5,075.00	PSTE	6.28	T1B050TL-1	\$ 230.00	S1T	15.133	T2H025TW-2	-	S2T	15.135
T100LB1-60T	\$ 3,735.00	PSTE	6.28	T1B060TL-1	\$ 230.00	S1T	15.133	T2H030TW	\$ 785.00	S2T	15.135
T100LF1-48D	\$ 5,075.00	PSTE	6.28	T1B070TL-1	\$ 262.00	S1T	15.133	T2H030TW-2	-	S2T	15.135
T1200D1-48M	\$ 12,900.00	PSTE	6.27	T1B080TL-1	\$ 262.00	S1T	15.133	T2H040TW	\$ 785.00	S2T	15.135
T1200D1-60M	\$ 10,830.00	PSTE	6.27	T1B090TL-1	\$ 262.00	S1T	15.133	T2H040TW-2	-	S2T	15.135
T1200D2-48M	\$ 14,650.00	PSTE	6.27	T1B100TL-1	\$ 262.00	S1T	15.133	T2H050MW	\$ 628.00	S2T	15.135
T1200D2-60M	\$ 12,130.00	PSTE	6.27	T1N015TL	\$ 402.00	S1T	15.133	T2H050TW	\$ 785.00	S2T	15.135
T1200DB1-48MM	\$ 22,900.00	PSTE	6.29	T1N020TL	\$ 402.00	S1T	15.133	T2H050TW-2	-	S2T	15.135
T1200DB1-60LM	\$ 20,830.00	PSTE	6.29	T1N025TL	\$ 402.00	S1T	15.133	T2H060BW	\$ 1,243.00	S2T	15.135
T1200DF1-48LM	\$ 22,900.00	PSTE	6.29	T1N030TL	\$ 402.00	S1T	15.133	T2H060BW-2	-	S2T	15.135
T1200DF1-60KM	\$ 20,830.00	PSTE	6.29	T1N040TL	\$ 402.00	S1T	15.133	T2H060E5W	-	S2T	15.135
T125D1-48	\$ 2,735.00	PSTE	6.27	T1N050TL	\$ 402.00	S1T	15.133	T2H060TW	\$ 785.00	S2T	15.135
T125D1-60	\$ 2,705.00	PSTE	6.27	T1N060TL	\$ 402.00	S1T	15.133	T2H060TW-2	-	S2T	15.135

T2H070TW – T6350PS1

Catalog number	List price	Discount schedule	Page number	Catalog number	List price	Discount schedule	Page number	Catalog number	List price	Discount schedule	Page number
T2H070TW	\$ 961.00	S2T	15.135	T300LF1-48FM	\$ 8,860.00	PSTE	6.28	T4045SF1	\$ 39.00	AT	12.5
T2H070TW-2	-	S2T	15.135	T300LF1-60F	\$ 7,580.00	PSTE	6.28	T4050PSF1	\$ 45.00	AT	12.5
T2H080TW	\$ 961.00	S2T	15.135	T350D1-48	\$ 5,080.00	PSTE	6.27	T4075PSF1	\$ 50.00	AT	12.5
T2H080TW-2	-	S2T	15.135	T350D1-60	\$ 4,850.00	PSTE	6.27	T41.5K1	\$ 230.00	AT	12.5
T2H090TW	\$ 961.00	S2T	15.135	T350D2-48M	\$ 7,830.00	PSTE	6.27	T4100PSF1	\$ 55.00	AT	12.5
T2H090TW-2	-	S2T	15.135	T350D2-60M	\$ 6,550.00	PSTE	6.27	T4150PSF1	\$ 59.00	AT	12.5
T2H100BW	\$ 1,419.00	S2T	15.135	T350DB1-48D	\$ 8,680.00	PSTE	6.29	T41K1	\$ 160.00	AT	12.5
T2H100BW-2	-	S2T	15.135	T350DB1-60C	\$ 7,450.00	PSTE	6.29	T4200PSF1	\$ 70.00	AT	12.5
T2H100E5W	-	S2T	15.135	T350DF1-48F	\$ 8,680.00	PSTE	6.29	T4250PSF1	\$ 78.00	AT	12.5
T2H100MW	\$ 753.00	S2T	15.135	T350DF1-60F	\$ 7,450.00	PSTE	6.29	T42K1	\$ 280.00	AT	12.5
T2H100TW	\$ 961.00	S2T	15.135	T350L1-48M	\$ 7,700.00	PSTE	6.26	T4300PSF1	\$ 85.00	AT	12.5
T2H100TW-2	-	S2T	15.135	T350L1-60M	\$ 6,260.00	PSTE	6.26	T4350PSF1	\$ 92.00	AT	12.5
T2S015TW	\$ 575.00	S2T	15.135	T350L2-48M	\$ 8,550.00	PSTE	6.26	T43K1	\$ 395.00	AT	12.5
T2S015TW-2	-	S2T	15.135	T350L2-60M	\$ 6,910.00	PSTE	6.26	T4500PSF1	\$ 123.00	AT	12.5
T2S020MW	\$ 498.00	S2T	15.135	T350LB1-48DM	\$ 11,300.00	PSTE	6.28	T45K1	\$ 660.00	AT	12.5
T2S020TW	\$ 575.00	S2T	15.135	T350LB1-60CM	\$ 8,860.00	PSTE	6.28	T4750PS1	\$ 145.00	AT	12.5
T2S020TW-2	-	S2T	15.135	T350LF1-48FM	\$ 11,300.00	PSTE	6.28	T500D1-48M	\$ 6,260.00	PSTE	6.27
T2S025BW	\$ 1,033.00	S2T	15.135	T350LF1-60FM	\$ 8,860.00	PSTE	6.28	T500D1-60	\$ 5,080.00	PSTE	6.27
T2S025BW-2	-	S2T	15.135	T3N060TW	\$ 406.00	S3T	15.137	T500D2-48M	\$ 6,910.00	PSTE	6.27
T2S025E5W	-	S2T	15.135	T3N070TW	\$ 489.00	S3T	15.137	T500D2-60M	\$ 7,830.00	PSTE	6.27
T2S025TW	\$ 575.00	S2T	15.135	T3N080TW	\$ 489.00	S3T	15.137	T500DB1-48GM	\$ 11,460.00	PSTE	6.29
T2S025TW-2	-	S2T	15.135	T3N090TW	\$ 489.00	S3T	15.137	T500DB1-60E	\$ 9,180.00	PSTE	6.29
T2S030TW	\$ 575.00	S2T	15.135	T3N100TW	\$ 489.00	S3T	15.137	T500DF1-48HM	\$ 11,460.00	PSTE	6.29
T2S030TW-2	-	S2T	15.135	T3N125TW	\$ 1,034.00	S3T	15.137	T500DF1-60G	\$ 9,180.00	PSTE	6.29
T2S040TW	\$ 575.00	S2T	15.135	T3N150TW	\$ 1,034.00	S3T	15.137	T500L1-48M	\$ 9,350.00	PSTE	6.26
T2S040TW-2	-	S2T	15.135	T3N175TW	\$ 1,034.00	S3T	15.137	T500L1-60M	\$ 7,700.00	PSTE	6.26
T2S050MW	\$ 558.00	S2T	15.135	T3N200TW	\$ 1,034.00	S3T	15.137	T500L2-48M	\$ 10,350.00	PSTE	6.26
T2S050TW	\$ 575.00	S2T	15.135	T3N225TW	\$ 1,034.00	S3T	15.137	T500L2-60M	\$ 8,550.00	PSTE	6.26
T2S050TW-2	-	S2T	15.135	T3S060TW	\$ 523.00	S3T	15.137	T500LB1-48GM	\$ 14,550.00	PSTE	6.28
T2S060BW	\$ 1,033.00	S2T	15.135	T3S070TW	\$ 641.00	S3T	15.137	T500LB1-60EM	\$ 11,800.00	PSTE	6.28
T2S060BW-2	-	S2T	15.135	T3S080TW	\$ 641.00	S3T	15.137	T500LF1-48HM	\$ 14,550.00	PSTE	6.28
T2S060E5W	-	S2T	15.135	T3S090TW	\$ 641.00	S3T	15.137	T500LF1-60GM	\$ 11,800.00	PSTE	6.28
T2S060TW	\$ 575.00	S2T	15.135	T3S100MW	\$ 711.00	S3T	15.137	T600D1-48M	\$ 7,700.00	PSTE	6.27
T2S060TW-2	-	S2T	15.135	T3S100TW	\$ 641.00	S3T	15.137	T600D1-60M	\$ 6,260.00	PSTE	6.27
T2S070TW	\$ 661.00	S2T	15.135	T3S125MW	\$ 734.00	S3T	15.137	T600D2-48M	\$ 8,550.00	PSTE	6.27
T2S070TW-2	-	S2T	15.135	T3S125TW	\$ 1,430.00	S3T	15.137	T600D2-60M	\$ 6,910.00	PSTE	6.27
T2S080TW	\$ 661.00	S2T	15.135	T3S150DW	\$ 714.00	S3T	15.137	T600DB1-48JM	\$ 12,900.00	PSTE	6.29
T2S080TW-2	-	S2T	15.135	T3S150MW	\$ 860.00	S3T	15.137	T600DB1-60GM	\$ 11,460.00	PSTE	6.29
T2S090TW	\$ 661.00	S2T	15.135	T3S150TW	\$ 1,430.00	S3T	15.137	T600DF1-48HM	\$ 12,900.00	PSTE	6.29
T2S090TW-2	-	S2T	15.135	T3S175TW	\$ 1,430.00	S3T	15.137	T600DF1-60HM	\$ 11,460.00	PSTE	6.29
T2S100BW	\$ 1,119.00	S2T	15.135	T3S200MW	\$ 915.00	S3T	15.137	T600L1-60M	\$ 9,350.00	PSTE	6.26
T2S100BW-2	-	S2T	15.135	T3S200TW	\$ 1,430.00	S3T	15.137	T600L148M	\$ 10,830.00	PSTE	6.26
T2S100E5W	-	S2T	15.135	T3S225DW	\$ 1,003.00	S3T	15.137	T600L2-48M	\$ 11,830.00	PSTE	6.26
T2S100MW	\$ 670.00	S2T	15.135	T3S225TW	\$ 1,430.00	S3T	15.137	T600L2-60M	\$ 10,350.00	PSTE	6.26
T2S100TW	\$ 661.00	S2T	15.135	T400D1-48	\$ 5,080.00	PSTE	6.27	T600LB1-48JM	\$ 16,030.00	PSTE	6.28
T2S100TW-2	-	S2T	15.135	T400D1-60	\$ 5,080.00	PSTE	6.27	T600LB1-60GM	\$ 14,550.00	PSTE	6.28
T300D1-48	\$ 4,850.00	PSTE	6.27	T400D2-48M	\$ 7,830.00	PSTE	6.27	T600LF1-48HM	\$ 16,030.00	PSTE	6.28
T300D1-60	\$ 4,370.00	PSTE	6.27	T400D2-60M	\$ 7,830.00	PSTE	6.27	T600LF1-60HB	\$ 14,550.00	PSTE	6.28
T300D2-48M	\$ 6,550.00	PSTE	6.27	T400DB1-48E	\$ 9,180.00	PSTE	6.29	T6045S1	\$ 41.00	AT	12.6
T300D2-60M	\$ 5,770.00	PSTE	6.27	T400DB1-60D	\$ 8,680.00	PSTE	6.29	T6050PS1	\$ 47.00	AT	12.6
T300DB1-48C	\$ 7,450.00	PSTE	6.29	T400DF1-48G	\$ 9,180.00	PSTE	6.29	T6075PS1	\$ 52.00	AT	12.6
T300DB1-60B	\$ 6,870.00	PSTE	6.29	T400DF1-60F	\$ 8,680.00	PSTE	6.29	T61.5K1	\$ 258.00	AT	12.6
T300DF1-48F	\$ 7,450.00	PSTE	6.29	T400L1-48M	\$ 7,700.00	PSTE	6.26	T6100PS1	\$ 58.00	AT	12.6
T300DF1-60F	\$ 6,870.00	PSTE	6.29	T400L1-60M	\$ 7,700.00	PSTE	6.26	T6150PS1	\$ 73.00	AT	12.6
T300L1-48M	\$ 6,260.00	PSTE	6.26	T400L2-48M	\$ 8,550.00	PSTE	6.26	T61K1	\$ 220.00	AT	12.6
T300L1-60	\$ 5,080.00	PSTE	6.26	T400L2-60M	\$ 8,550.00	PSTE	6.26	T6200PS1	\$ 87.00	AT	12.6
T300L2-48M	\$ 6,910.00	PSTE	6.26	T400LB1-48EM	\$ 11,800.00	PSTE	6.28	T6250PS1	\$ 92.00	AT	12.6
T300L2-60M	\$ 7,830.00	PSTE	6.26	T400LB1-60DM	\$ 11,300.00	PSTE	6.28	T62K1	\$ 319.00	AT	12.6
T300LB1-48CM	\$ 8,860.00	PSTE	6.28	T400LF1-48GM	\$ 11,800.00	PSTE	6.28	T6300PS1	\$ 102.00	AT	12.6
T300LB1-60B	\$ 7,580.00	PSTE	6.28	T400LF1-60FM	\$ 11,300.00	PSTE	6.28	T6350PS1	\$ 106.00	AT	12.6

T63K1 – TC4350F1

Alphanumeric

0

Catalog number	List price	Discount schedule	Page number	Catalog number	List price	Discount schedule	Page number	Catalog number	List price	Discount schedule	Page number
T63K1	\$ 622.00	AT	12.6	T900LB1-60KM	\$ 27,500.00	PSTE	6.28	TAL16-30-10-*	\$ 218.00	AA	1.122
T6500PS1	\$ 132.00	AT	12.6	T900LF1-48KM	\$ 28,200.00	PSTE	6.28	TAL16-40-00-*	\$ 268.00	AA	1.122
T65K1	\$ 1,222.00	AT	12.6	T900LF1-60JB	\$ 27,500.00	PSTE	6.28	TAL26-22-00-*	\$ 303.00	AA	1.122
T6750PS1	\$ 175.00	AT	12.6	TA110DU110	\$ 165.00	TCA	2.6	TAL26-30-01-*	\$ 263.00	AA	1.122
T700D1-48M	\$ 9,350.00	PSTE	6.27	TA110DU90	\$ 165.00	TCA	2.6	TAL26-30-10-*	\$ 263.00	AA	1.122
T700D1-60M	\$ 7,700.00	PSTE	6.27	TA200DU110	\$ 165.00	TCA	2.6	TAL26-40-00-*	\$ 303.00	AA	1.122
T700D2-48M	\$ 10,350.00	PSTE	6.27	TA200DU135	\$ 225.00	TCA	2.6	TAL30-30-01-*	\$ 338.00	AA	1.122
T700D2-60M	\$ 8,550.00	PSTE	6.27	TA200DU150	\$ 225.00	TCA	2.6	TAL30-30-10-*	\$ 338.00	AA	1.122
T700DB1-48JM	\$ 15,850.00	PSTE	6.29	TA200DU175	\$ 225.00	TCA	2.6	TAL40-30-01-*	\$ 354.00	AA	1.122
T700DB1-60JM	\$ 12,900.00	PSTE	6.29	TA200DU200	\$ 225.00	TCA	2.6	TAL40-30-10-*	\$ 354.00	AA	1.122
T700DF1-48JM	\$ 15,850.00	PSTE	6.29	TA200DU90	\$ 165.00	TCA	2.6	TAL9-22-00-*	\$ 190.00	AA	1.122
T700DF1-60HM	\$ 12,900.00	PSTE	6.29	TA25DU0.16	\$ 63.00	TAA	2.6	TAL9-30-01-*	\$ 141.00	AA	1.122
T700L1-48M	\$ 12,900.00	PSTE	6.26	TA25DU0.25	\$ 63.00	TAA	2.6	TAL9-30-10-*	\$ 141.00	AA	1.122
T700L1-60M	\$ 10,830.00	PSTE	6.26	TA25DU0.4	\$ 63.00	TAA	2.6	TAL9-40-00-*	\$ 190.00	AA	1.122
T700L2-48M	\$ 14,000.00	PSTE	6.26	TA25DU0.63	\$ 63.00	TAA	2.6	TC2050F	\$ 57.00	AT	12.7
T700L2-60M	\$ 11,830.00	PSTE	6.26	TA25DU1.0	\$ 63.00	TAA	2.6	TC2075F	\$ 64.00	AT	12.7
T700LB1-48JM	\$ 19,400.00	PSTE	6.28	TA25DU1.4	\$ 63.00	TAA	2.6	TC2100F	\$ 76.00	AT	12.7
T700LB1-60JM	\$ 16,030.00	PSTE	6.28	TA25DU1.8	\$ 63.00	TAA	2.6	TC2150F	\$ 101.00	AT	12.7
T700LF1-48JM	\$ 19,400.00	PSTE	6.28	TA25DU11	\$ 63.00	TAA	2.6	TC2200F	\$ 114.00	AT	12.7
T700LF1-60HB	\$ 16,030.00	PSTE	6.28	TA25DU14	\$ 63.00	TAA	2.6	TC2250F	\$ 125.00	AT	12.7
T7DU1.0	\$ 48.00	AA	4.8	TA25DU19	\$ 63.00	TAA	2.6	TC2300F	\$ 139.00	AT	12.7
T7DU1.6	\$ 48.00	AA	4.8	TA25DU2.4	\$ 63.00	TAA	2.6	TC2350F	\$ 161.00	AT	12.7
T7DU12.0	\$ 48.00	AA	4.8	TA25DU25	\$ 63.00	TAA	2.6	TC2500F	\$ 179.00	AT	12.7
T7DU2.4	\$ 48.00	AA	4.8	TA25DU3.1	\$ 63.00	TAA	2.6	TC2750F	\$ 267.00	AT	12.7
T7DU4.0	\$ 48.00	AA	4.8	TA25DU32	\$ 63.00	TAA	2.6	TC305021	\$ 81.00	AT	12.8
T7DU6.0	\$ 48.00	AA	4.8	TA25DU4.0	\$ 63.00	TAA	2.6	TC3050F	\$ 57.00	AT	12.9
T7DU9.0	\$ 48.00	AA	4.8	TA25DU5.0	\$ 63.00	TAA	2.6	TC307521	\$ 83.00	AT	12.8
T7DUO.16	\$ 48.00	AA	4.8	TA25DU6.5	\$ 63.00	TAA	2.6	TC3075F	\$ 64.00	AT	12.9
T7DUO.24	\$ 48.00	AA	4.8	TA25DU8.5	\$ 63.00	TAA	2.6	TC310021	\$ 94.00	AT	12.8
T7DUO.4	\$ 48.00	AA	4.8	TA42DU25	\$ 78.00	TBA	2.6	TC3100F	\$ 76.00	AT	12.9
T7DUO.6	\$ 48.00	AA	4.8	TA42DU32	\$ 78.00	TBA	2.6	TC315021	\$ 120.00	AT	12.8
T800D1-48M	\$ 10,830.00	PSTE	6.27	TA42DU42	\$ 78.00	TBA	2.6	TC3150F	\$ 101.00	AT	12.9
T800D1-60M	\$ 9,350.00	PSTE	6.27	TA450DU185	\$ 488.00	TCA	2.6	TC320021	\$ 133.00	AT	12.8
T800D2-48M	\$ 12,130.00	PSTE	6.27	TA450DU235	\$ 488.00	TCA	2.6	TC3200F	\$ 114.00	AT	12.9
T800D2-60M	\$ 10,350.00	PSTE	6.27	TA450DU310	\$ 488.00	TCA	2.6	TC325021	\$ 154.00	AT	12.8
T800DB1-48KM	\$ 17,330.00	PSTE	6.29	TA75DU25	\$ 102.00	TBA	2.6	TC3250F	\$ 125.00	AT	12.9
T800DB1-60JM	\$ 15,850.00	PSTE	6.29	TA75DU32	\$ 102.00	TBA	2.6	TC330021	\$ 178.00	AT	12.8
T800DF1-48JM	\$ 17,330.00	PSTE	6.29	TA75DU42	\$ 102.00	TBA	2.6	TC3300F	\$ 139.00	AT	12.9
T800DF1-60JM	\$ 15,850.00	PSTE	6.29	TA75DU52	\$ 102.00	TBA	2.6	TC335021	\$ 193.00	AT	12.8
T800L1-48M	\$ 21,000.00	PSTE	6.26	TA75DU63	\$ 102.00	TBA	2.6	TC3350F	\$ 161.00	AT	12.9
T800L1-60M	\$ 12,900.00	PSTE	6.26	TA75DU80	\$ 102.00	TBA	2.6	TC350021	\$ 210.00	AT	12.8
T800L2-48M	\$ 22,300.00	PSTE	6.26	TA80DU42	\$ 135.00	TCA	2.6	TC3500F	\$ 179.00	AT	12.9
T800L2-60M	\$ 14,000.00	PSTE	6.26	TA80DU52	\$ 135.00	TCA	2.6	TC375021	\$ 260.00	AT	12.8
T800LB1-48KM	\$ 27,500.00	PSTE	6.28	TA80DU63	\$ 135.00	TCA	2.6	TC3750F	\$ 267.00	AT	12.9
T800LB1-60JM	\$ 19,400.00	PSTE	6.28	TA80DU80	\$ 135.00	TCA	2.6	TC40501	\$ 55.00	AT	12.7
T800LF1-48JM	\$ 27,500.00	PSTE	6.28	TAE110-30-00-*	\$ 755.00	AA	1.122	TC4050F1	\$ 62.00	AT	12.9
T800LF1-60JB	\$ 19,400.00	PSTE	6.28	TAE110-30-11-*	\$ 795.00	AA	1.122	TC40751	\$ 62.00	AT	12.7
T900D1-48M	\$ 10,830.00	PSTE	6.27	TAE45-40-00-*	\$ 405.00	AA	1.122	TC4075F1	\$ 70.00	AT	12.9
T900D1-60M	\$ 10,830.00	PSTE	6.27	TAE50-30-00-*	\$ 388.00	AA	1.122	TC41001	\$ 72.00	AT	12.7
T900D2-48M	\$ 12,130.00	PSTE	6.27	TAE50-30-11-*	\$ 428.00	AA	1.122	TC4100F1	\$ 91.00	AT	12.9
T900D2-60M	\$ 12,130.00	PSTE	6.27	TAE50-40-00-*	\$ 505.00	AA	1.122	TC41501	\$ 88.00	AT	12.7
T900DB1-48KM	\$ 18,030.00	PSTE	6.29	TAE75-30-00-*	\$ 560.00	AA	1.122	TC4150F1	\$ 109.00	AT	12.9
T900DB1-60KM	\$ 17,330.00	PSTE	6.29	TAE75-30-11-*	\$ 600.00	AA	1.122	TC42001	\$ 101.00	AT	12.7
T900DF1-48KM	\$ 18,030.00	PSTE	6.29	TAE75-40-00-*	\$ 615.00	AA	1.122	TC4200F1	\$ 127.00	AT	12.9
T900DF1-60JM	\$ 17,330.00	PSTE	6.29	TAE95-30-00-*	\$ 600.00	AA	1.122	TC42501	\$ 120.00	AT	12.7
T900L1-48M	\$ 21,000.00	PSTE	6.26	TAE95-30-11-*	\$ 640.00	AA	1.122	TC4250F1	\$ 146.00	AT	12.9
T900L1-60M	\$ 21,000.00	PSTE	6.26	TAL12-30-01-*	\$ 173.00	AA	1.122	TC43001	\$ 130.00	AT	12.7
T900L2-48M	\$ 22,300.00	PSTE	6.26	TAL12-30-10-*	\$ 173.00	AA	1.122	TC4300F1	\$ 172.00	AT	12.9
T900L2-60M	\$ 22,300.00	PSTE	6.26	TAL16-22-00-*	\$ 268.00	AA	1.122	TC43501	\$ 154.00	AT	12.7
T900LB1-48KM	\$ 28,200.00	PSTE	6.28	TAL16-30-01-*	\$ 218.00	AA	1.122	TC4350F1	\$ 178.00	AT	12.9

TC45001 – ZLS255

Catalog number	List price	Discount schedule	Page number	Catalog number	List price	Discount schedule	Page number	Catalog number	List price	Discount schedule	Page number
TC45001	\$ 168.00	AT	12.7	UA75-30-11-84	\$ 480.00	AA	1.15	ZAF75-*	\$ 120.00	ABA	1.26
TC4500F1	\$ 204.00	AT	12.9	UA95-30-00-84	\$ 465.00	AA	1.15	ZAF750-*	\$ 525.00	ABA	1.26
TC47501	\$ 242.00	AT	12.7	UA95-30-11-84	\$ 495.00	AA	1.15	ZAL16-*	\$ 36.00	ABA	1.26
TC60501	\$ 56.00	AT	12.8	VB6CM-*	\$ 105.00	AA	4.3	ZAL16Z-*	\$ 36.00	ABA	1.26
TC60751	\$ 63.00	AT	12.8	VB6CMSP-*01	\$ 105.00	AA	4.3	ZAL40-*	\$ 42.00	ABA	1.26
TC61001	\$ 76.00	AT	12.8	VB6M-*	\$ 104.00	AA	4.3	ZL110	\$ 255.00	ABA	1.25
TC61501	\$ 100.00	AT	12.8	VB6M-*01	\$ 104.00	AA	4.3	ZL1350	\$ 4,255.00	ABA	1.25
TC62001	\$ 113.00	AT	12.8	VB6MFP-*	\$ 104.00	AA	4.3	ZL145	\$ 300.00	ABA	1.25
TC62501	\$ 124.00	AT	12.8	VB6MFP-*01	\$ 104.00	AA	4.3	ZL1650	\$ 4,890.00	ABA	1.25
TC63001	\$ 137.00	AT	12.8	VB6MSP-*	\$ 104.00	AA	4.3	ZL185	\$ 420.00	ABA	1.25
TC63501	\$ 160.00	AT	12.8	VB6MSP-*01	\$ 104.00	AA	4.3	ZL210	\$ 525.00	ABA	1.25
TC65001	\$ 178.00	AT	12.8	VB7M-*	\$ 143.00	AA	4.3	ZL260	\$ 855.00	ABA	1.25
TC67501	\$ 264.00	AT	12.8	VB7M-*01	\$ 143.00	AA	4.3	ZL300	\$ 1,020.00	ABA	1.25
TE5S-115	\$ 120.00	ABA	1.31	VB7MFP-*	\$ 143.00	AA	4.3	ZL400	\$ 1,716.00	ABA	1.25
TE5S-230	\$ 120.00	ABA	1.31	VB7MFP-*01	\$ 143.00	AA	4.3	ZL460	\$ 2,434.00	ABA	1.25
TE5S-24	\$ 120.00	ABA	1.31	VB7MSP-*	\$ 143.00	AA	4.3	ZL50	\$ 113.00	ABA	1.25
TNL22E-*	\$ 121.00	KCN	7.6	VB7MSP-*01	\$ 143.00	AA	4.3	ZL580	\$ 3,795.00	ABA	1.25
TNL31E-*	\$ 121.00	KCN	7.6	VBC6M-*01	\$ 105.00	AA	4.3	ZL63	\$ 135.00	ABA	1.25
TNL40E-*	\$ 121.00	KCN	7.6	VBC6MFP-*	\$ 105.00	AA	4.3	ZL75	\$ 158.00	ABA	1.25
TNL44E-*	\$ 180.00	KCN	7.6	VBC6MFP-*01	\$ 105.00	AA	4.3	ZL750	\$ 3,960.00	ABA	1.25
TNL62E-*	\$ 180.00	KCN	7.6	VBC6MSP-*	\$ 105.00	AA	4.3	ZL95	\$ 225.00	ABA	1.25
TP180DA	\$ 108.00	ABA	1.17	VBC7M-*	\$ 156.00	AA	4.3	ZLS100	\$ 25.00	CB13	20.7
TP180IA	\$ 108.00	ABA	1.17	VBC7M-*01	\$ 156.00	AA	4.3	ZLS101	\$ 20.00	CB13	20.7
TP40DA	\$ 108.00	ABA	1.17	VBC7MFP-*	\$ 156.00	AA	4.3	ZLS160	\$ 20.00	CB13	20.6
TP40IA	\$ 108.00	ABA	1.17	VBC7MFP-*01	\$ 156.00	AA	4.3	ZLS161	\$ 20.00	CB13	20.6
UA1-120	\$ 82.50	MA	5.4	VBC7MSP-*	\$ 156.00	AA	4.3	ZLS162	\$ 20.00	CB13	20.6
UA1-230	\$ 82.50	MA	5.4	VBC7MSP-*01	\$ 156.00	AA	4.3	ZLS163	\$ 20.00	CB13	20.6
UA1-24	\$ 82.50	MA	5.4	VE5-1	\$ 45.00	ABA	1.17	ZLS166	\$ 30.00	CB13	20.6
UA1-400	\$ 82.50	MA	5.4	VE5-2	\$ 45.00	ABA	1.17	ZLS167	\$ 30.00	CB13	20.6
UA1-415	\$ 82.50	MA	5.4	VM300/460H	\$ 130.00	ABA	1.17	ZLS168	\$ 30.00	CB13	20.6
UA1-48	\$ 82.50	MA	5.4	VM300/460V	\$ 250.00	ABA	1.17	ZLS169	\$ 30.00	CB13	20.6
UA1-60	\$ 82.50	MA	5.4	VM300H	\$ 110.00	ABA	1.17	ZLS170	\$ 30.00	CB13	20.6
UA1-HK-120	\$ 97.50	MA	5.4	VM300V	\$ 205.00	ABA	1.17	ZLS171	\$ 30.00	CB13	20.6
UA1-HK-230	\$ 97.50	MA	5.4	VM5-1	\$ 21.00	ABA	1.17	ZLS172	\$ 30.00	CB13	20.6
UA1-HK-24	\$ 97.50	MA	5.4	VM750H	\$ 150.00	ABA	1.17	ZLS173	\$ 30.00	CB13	20.6
UA1-HK-400	\$ 97.50	MA	5.4	VM750V	\$ 270.00	ABA	1.17	ZLS174	\$ 10.00	CB13	20.6
UA1-HK-415	\$ 97.50	MA	5.4	WB75A-*	\$ 84.00	ABA	1.25	ZLS176	\$ 20.00	CB13	20.6
UA1-HK-48	\$ 97.50	MA	5.4	WLA12-30-84	\$ 422.00	AA	5.14	ZLS177	\$ 20.00	CB13	20.6
UA1-HK-60	\$ 97.50	MA	5.4	WLA16-30-84	\$ 464.00	AA	5.14	ZLS178	\$ 20.00	CB13	20.6
UA110	\$ 266.00	CB8	14.42	WLA26-30-84	\$ 531.00	AA	5.14	ZLS179	\$ 20.00	CB13	20.6
UA110-30-00-84	\$ 525.00	AA	1.15	WLA9-30-84	\$ 294.00	AA	5.14	ZLS183	\$ 60.00	CB13	20.6
UA110-30-11-84	\$ 570.00	AA	1.15	XUS001628	\$ 800.00	TL	13.8	ZLS183BT	\$ 60.00	CB13	20.6
UA12	\$ 266.00	CB8	14.42	XUS001629	\$ 300.00	TL	13.8	ZLS183TB	\$ 60.00	CB13	20.6
UA230	\$ 266.00	CB8	14.42	XUS002518	\$ 1,200.00	TL	13.9	ZLS183TT	\$ 60.00	CB13	20.6
UA24	\$ 266.00	CB8	14.42	XUS002519	\$ 495.00	TL	13.9	ZLS189	\$ 90.00	CB13	20.6
UA26-30-10-84	\$ 225.00	AA	1.15	ZA110-*	\$ 60.00	ABA	1.26	ZLS189BT	\$ 90.00	CB13	20.6
UA30-30-10-84	\$ 338.00	AA	1.15	ZA16-*	\$ 24.00	ABA	1.26	ZLS189TB	\$ 90.00	CB13	20.6
UA4-120	\$ 93.00	MA	5.17	ZA185-*	\$ 150.00	ABA	1.26	ZLS189TT	\$ 90.00	CB13	20.6
UA4-208	\$ 93.00	MA	5.17	ZA300-*	\$ 180.00	ABA	1.26	ZLS200	\$ 95.00	CB13	20.5
UA4-240	\$ 93.00	MA	5.17	ZA40-*	\$ 30.00	ABA	1.26	ZLS224	\$ 120.00	CB13	20.5
UA4-400	\$ 93.00	MA	5.17	ZA75-*	\$ 57.00	ABA	1.109	ZLS225	\$ 110.00	CB13	20.5
UA4-480	\$ 93.00	MA	5.17	ZAE110-*	\$ 90.00	ABA	1.26	ZLS239	\$ 10.00	CB13	20.7
UA4-HK-230	\$ 117.00	MA	5.17	ZAE16-*	\$ 24.00	ABA	1.26	ZLS240	\$ 110.00	CB13	20.5
UA4-HK-400	\$ 117.00	MA	5.17	ZAE40-*	\$ 30.00	ABA	1.26	ZLS241	\$ 120.00	CB13	20.5
UA4-HK-480	\$ 117.00	MA	5.17	ZAE75-*	\$ 57.00	ABA	1.26	ZLS250	\$ 60.00	CB13	20.5
UA48	\$ 266.00	CB8	14.42	ZAF110-*	\$ 165.00	ABA	1.26	ZLS251	\$ 60.00	CB13	20.5
UA50-30-00-84	\$ 345.00	AA	1.15	ZAF1650-*	\$ 920.00	ABA	1.26	ZLS252	\$ 60.00	CB13	20.5
UA50-30-11-84	\$ 375.00	AA	1.15	ZAF185-*	\$ 200.00	ABA	1.26	ZLS253	\$ 60.00	CB13	20.5
UA500	\$ 266.00	CB8	14.42	ZAF300-*	\$ 240.00	ABA	1.26	ZLS254	\$ 60.00	CB13	20.8
UA75-30-00-84	\$ 450.00	AA	1.15	ZAF460-*	\$ 450.00	ABA	1.26	ZLS255	\$ 60.00	CB13	20.8

ZLS722 – ZW750

Alphanumeric

0

Catalog number	List price	Discount schedule	Page number	Catalog number	List price	Discount schedule	Page number	Catalog number	List price	Discount schedule	Page number
ZLS722	\$ 30.00	CB13	20.7								
ZLS730	\$ 30.00	CB13	20.5								
ZLS750	\$ 240.00	CB13	20.4								
ZLS751	\$ 260.00	CB13	20.4								
ZLS752	\$ 290.00	CB13	20.4								
ZLS753	\$ 320.00	CB13	20.4								
ZLS754	\$ 340.00	CB13	20.4								
ZLS755	\$ 380.00	CB13	20.4								
ZLS756	\$ 390.00	CB13	20.4								
ZLS757	\$ 430.00	CB13	20.4								
ZLS758	\$ 590.00	CB13	20.4								
ZLS759	\$ 660.00	CB13	20.4								
ZLS766	\$ 470.00	CB13	20.4								
ZLS767	\$ 540.00	CB13	20.4								
ZLS806	\$ 28.00	CB13	20.5								
ZLS808	\$ 30.00	CB13	20.5								
ZLS810	\$ 15.00	CB13	20.8								
ZLS811	\$ 17.00	CB13	20.8								
ZLS812	\$ 22.00	CB13	20.8								
ZLS813	\$ 40.00	CB13	20.8								
ZLS815	\$ 22.00	CB13	20.8								
ZLS816	\$ 40.00	CB13	20.8								
ZLS820	\$ 100.00	CB13	20.8								
ZLS821	\$ 12.00	CB13	20.8								
ZLS825	\$ 90.00	CB13	20.8								
ZLS832	\$ 25.00	CB13	20.8								
ZLS833	\$ 50.00	CB13	20.8								
ZLT45	\$ 150.00	ABA	1.25								
ZLT50	\$ 150.00	ABA	1.25								
ZLT75	\$ 210.00	ABA	1.25								
ZLU110	\$ 347.00	ABA	1.25								
ZLU50	\$ 150.00	ABA	1.25								
ZLU75	\$ 215.00	ABA	1.25								
ZLU95	\$ 306.00	ABA	1.25								
ZP1650-*	\$ 1,620.00	ABA	1.26								
ZW185	\$ 130.00	ABA	1.29								
ZW300	\$ 180.00	ABA	1.29								
ZW460	\$ 190.00	ABA	1.29								
ZW750	\$ 230.00	ABA	1.29								

Alphanumeric