

# Plastic Limit switches

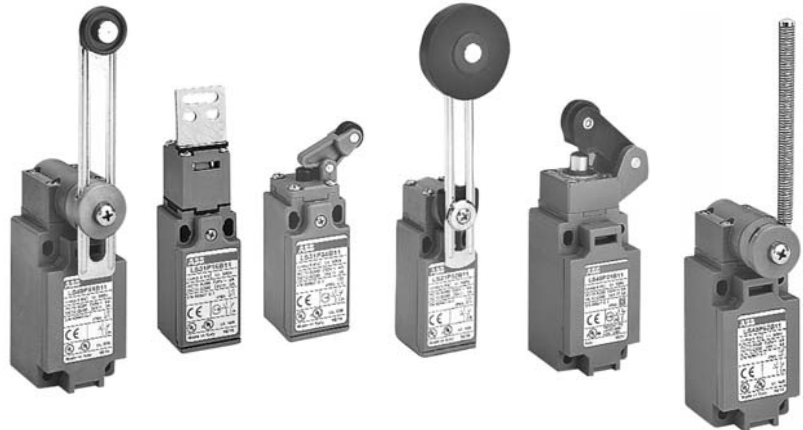

## Limit Switches

Plastic casing, 30mm & 40mm  
Assembled  
Components



9

### Description

Limit switches are made of reinforced UL-V0 thermoplastic fiberglass, offer double insulation  $\square$  and a degree of protection of IP 65 and UL Type 4.

Casings come in 2 dimensions:

- 30mm width  
– LS35P
- 40mm width  
– LS45P

### Applications

**Easy to use, electromechanical limit switches offer specific qualities:**

- Visible operation
- Electrically separated contacts
- Precise operating points (consistency)
- Immune to electromagnetic disturbances

**Limit switches used for these mechanical applications:**

- Presence/absence
- Positioning and travel limit
- Objects passing/counting

UL Listed file #E191693

## Selection guide

### 30mm & 40mm, IP65, UL Type 4

#### 30mm width — LS35P



LS35P16

LS35P11

LS35P13

LS35P31

CENELEC conformity

—

EN 50 047

EN 50 047

EN 50 047

Actuating device and actuation type

Key translation movement

Plain plunger

Roller plunger

Roller lever

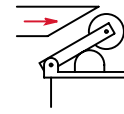
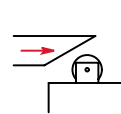
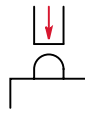
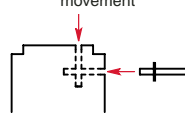

Positive contact opening



#### 40mm width — LS45P



LS45P11

LS45P13

LS45P31

LS45P41

CENELEC conformity

EN 50 041

EN 50 041

—

EN 50 041

Actuating device and actuation type

Plain plunger

Roller plunger

Roller lever

Roller lever

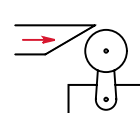
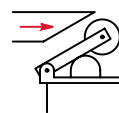
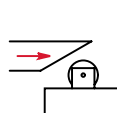
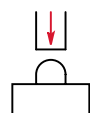

Positive contact opening



# Selection guide

## 30mm & 40mm, IP65, UL Type 4

Plastic  
Limit switches



LS35P32

LS35P41

LS35P51

LS35P71

LS35P91

—  
Roller lever

EN 50 047  
Roller lever

—  
Adjustable roller lever

—  
Adjustable rod lever

—  
Flexible rod

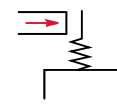
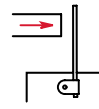
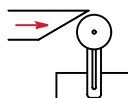
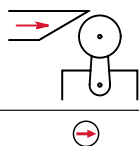
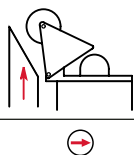

LS45P44

LS45P51

LS45P54

LS45P61

LS45P72

LS45P91

—  
Roller lever

—  
Adjustable roller levers

—  
Adjustable flexible and rigid rod levers

EN 50 041  
Flexible rod

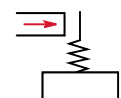
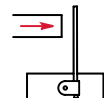
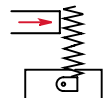
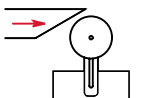
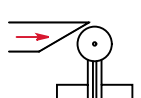
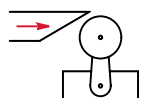

## General information

### 30mm & 40mm, IP65, UL Type 4

#### Applications

Easy to use, electromechanical limit switches offer specific qualities:

- Visible operation
- Able to switch strong currents (10 A conventional thermal current)
- Electrically separated contacts
- Precise operating points (consistency)
- Immune to electromagnetic disturbances

Limit switches used for these mechanical applications:

- Presence/absence
- Positioning and travel limit
- Objects passing/counting

#### Description

Limit switches, which are made of reinforced UL-V0 thermoplastic fiberglass, offer double insulation  and a degree of protection of IP 65 and UL type 4

Casings come in 2 dimensions:

- 30mm width  
– LS35P
- 40mm width  
– LS45P

9

30 or 40mm width casings with standardized dimensions corresponding to:

- EN 50047 for 30mm width
- EN 50041 for 40mm width

Mounting the casing:

- 2 x M4 screws on top part for 30mm width
- 2 or 4 x M5 screws for 40mm width

Block of 2 contacts:

- Contact configuration: N.O. + N.C., 2 N.O., 2 N.C.
- Positive opening operation
- Snap action or slow action
- Zb shape: the 2 contacts are electrically separated

Connecting terminals:

- M3.5 (+, -) pozidriv 2 screw
- Screw head with captive cable clamp
- Markings conform with IEC 947—1, IEC 947—5—1, EN 50005 and 50013 standards

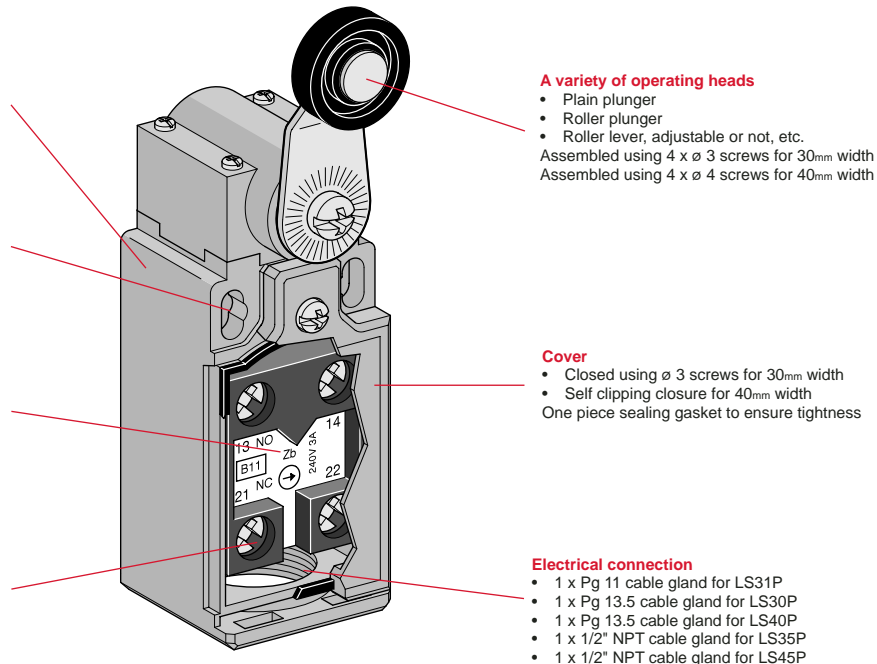

#### A variety of operating heads

- Plain plunger
  - Roller plunger
  - Roller lever, adjustable or not, etc.
- Assembled using 4 x  $\varnothing$  3 screws for 30mm width  
Assembled using 4 x  $\varnothing$  4 screws for 40mm width

#### Cover

- Closed using  $\varnothing$  3 screws for 30mm width
  - Self clipping closure for 40mm width
- One piece sealing gasket to ensure tightness

#### Electrical connection

- 1 x Pg 11 cable gland for LS31P
- 1 x Pg 13.5 cable gland for LS30P
- 1 x Pg 13.5 cable gland for LS40P
- 1 x 1/2" NPT cable gland for LS35P
- 1 x 1/2" NPT cable gland for LS45P

#### Catalog number explanation

**LS 35 P 41 B 11**

Limit switch

#### Casing width

- 30 = 30mm width+1 cable inlet for Pg 13.5 cable gland
- 31 = 30mm width+1 cable inlet for Pg 11 cable gland
- 35 = 30mm width+1 cable inlet for 1/2" NPT cable gland
- 40 = 40mm width+1 cable inlet for Pg 13.5 cable gland
- 45 = 40mm width+1 cable inlet for 1/2" NPT cable gland

Plastic casing

Operating heads: codes 10 – 93

#### Contact block

- 11: 1 N.O. contact + 1 N.C. contact
- 20: 2 N.O. contacts
- 02: 2 N.C. contacts

B: Zb Snap action

L: Zb Slow action (contact dependent)

D: Zb Slow action non-overlapping late make

C: Zb Slow action overlapping early make

# General information

## Implementation

### 30mm & 40mm, IP65, UL Type 4

Plastic  
Limit switches

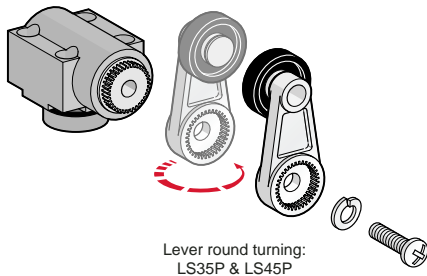

Lever round turning:  
LS35P & LS45P

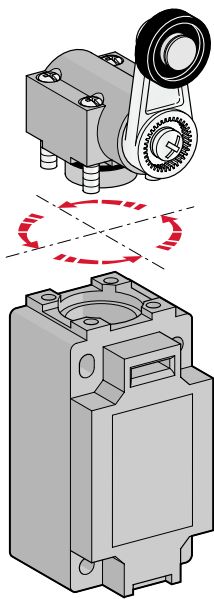

Head orientation:  
LS35P & LS45P

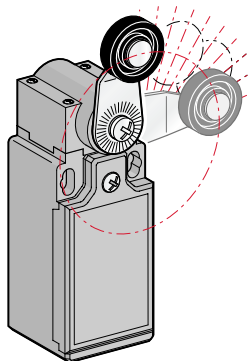

Free position adjustment  
10 in 10° of lever:  
LS35P

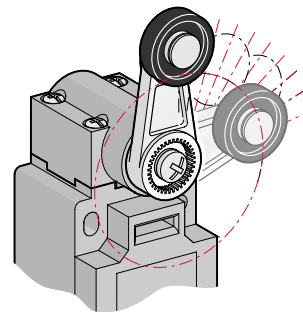

Free position adjustment  
9 in 9° of lever:  
LS45P

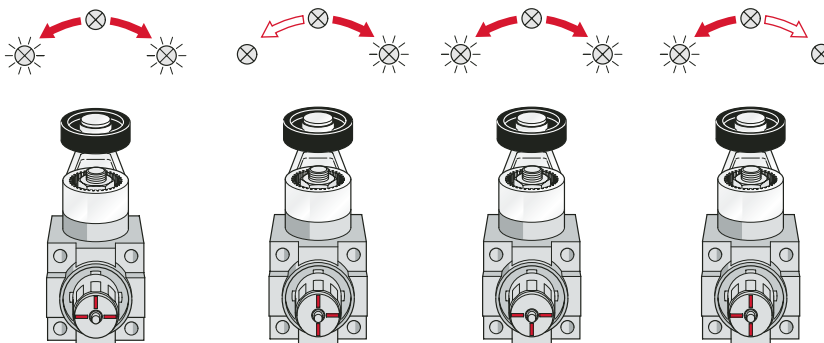
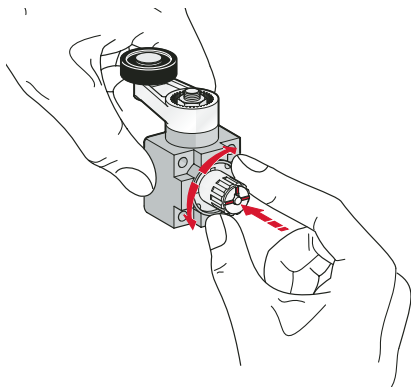

Operating mode selection only, LS45P

9

## Assembled 30mm, IP 65, UL Type 4

### Movement to be detected

#### Key translation, on end or lateral

#### On end

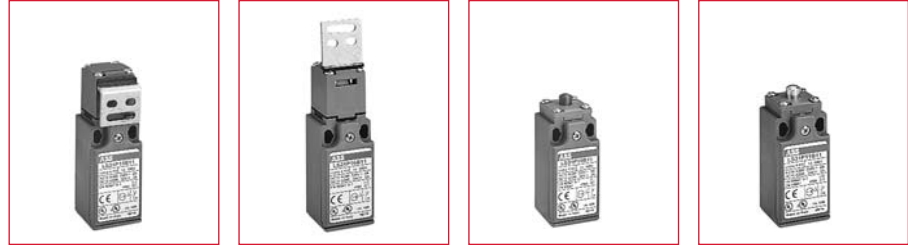

### Operating head type

	Right angle key	Straight key	Plain thermoplastic plunger	Plain steel plunger
Conformity / (N.C. contact with positive opening operation)			EN 50 047	EN 50 047
Maximum actuation speed <b>m/s</b>	0.5	0.5	0.5	0.5
Min. force: - actuation <b>N</b>	18	18	9	9
- positive opening operation <b>N</b>	60	60	44	44

9

	Catalog number List price	LS35P15B11 \$ 31	LS35P16B11 \$ 33	LS35P10B11 \$ 22	LS35P11B11 \$ 22
Snap action contacts 	Catalog number List price	LS35P15D11 33	LS35P16D11 35	LS35P10D11 23	LS35P11D11 23
Non-overlapping Slow action contacts 	Catalog number List price	LS35P15C11 34	LS35P16C11 36	LS35P10C11 24	LS35P11C11 24
Overlapping Slow action contacts 	Catalog number List price	LS35P15L02 34	LS35P16L02 36	LS35P10L02 24	LS35P11L02 24
Slow action contacts 	Catalog number List price	LS35P15L20 34	LS35P16L20 36	LS35P10L20 24	LS35P11L20 24
Slow action contacts 	Catalog number List price	LS35P15B02 34	LS35P16B02 36	LS35P10B02 24	LS35P11B02 24
Snap action contacts 	Weight (packing per unit) <b>kg</b>	0.085	0.085	0.065	0.070

### Approximate dimensions (mm)

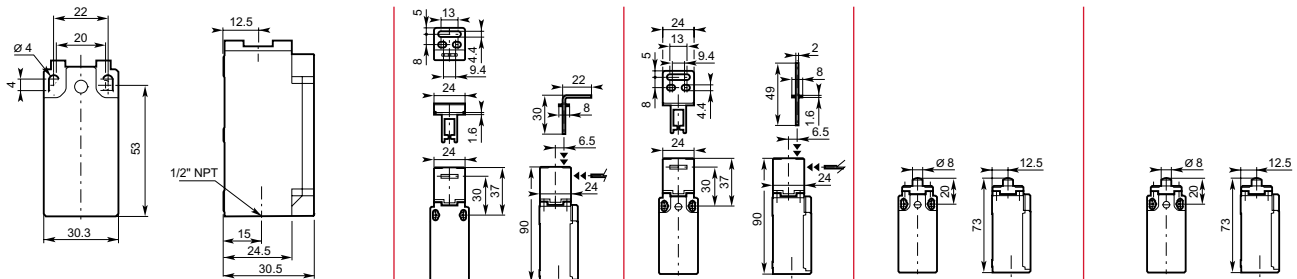

# Assembled 30mm, IP 65, UL Type 4

Plastic  
Limit switches

## 30° Cam Translat.

## 30° Unidirectional Cam Translation Movement



Plastic roller plunger	Plastic roller lever on plastic plunger	Plastic roller lever on steel plunger	Plastic roller lever on steel plunger	Plastic roller lever on plastic plunger
EN 50 047	EN 50 047	EN 50 047		
0.3	1	1	1	1
12	7	7	3	3
41	24	24	24	24

<b>LS35P13B11</b> <b>\$ 25</b> 0 1.4 3.3 7.8 11.2 mm 21-22 13-14 13-14 21-22 13-14	<b>LS35P30B11</b> <b>\$ 24</b> 0 3.0 7.1 16.9 24.4 mm 21-22 13-14 13-14 21-22 13-14	<b>LS35P31B11</b> <b>\$ 25</b> 0 3.0 7.1 16.9 24.4 mm 21-22 13-14 13-14 21-22 13-14	<b>LS35P32B11</b> <b>\$ 24</b> 0 2.6 6.2 14.7 21.3 mm 21-22 13-14 13-14 21-22 13-14	<b>LS35P34B11</b> <b>\$ 25</b> 0 2.6 6.2 14.7 21.3 mm 21-22 13-14 13-14 21-22 13-14
<b>LS35P13D11</b> <b>26</b> 0 2.6 5.1 11.4 mm 13-14 4.7	<b>LS35P30D11</b> <b>25</b> 0 5.6 10.9 24.4 mm 13-14 10.1	<b>LS35P31D11</b> <b>26</b> 0 5.6 10.9 24.4 mm 13-14 10.1	<b>LS35P32D11</b> <b>25</b> 0 4.9 9.4 21.1 mm 13-14 8.8	<b>LS35P34D11</b> <b>26</b> 0 4.9 9.4 21.1 mm 13-14 8.8
<b>LS35P13C11</b> <b>27</b> 0 4.6 7.0 11.4 mm 13-14 2.6	<b>LS35P30C11</b> <b>26</b> 0 9.8 15.0 24.4 mm 13-14 5.6	<b>LS35P31C11</b> <b>27</b> 0 9.8 15.0 24.4 mm 13-14 5.6	<b>LS35P32C11</b> <b>26</b> 0 8.5 13.0 21.1 mm 13-14 4.9	<b>LS35P34C11</b> <b>27</b> 0 8.5 13.0 21.1 mm 13-14 4.9
<b>LS35P13L02</b> <b>27</b> 0 2.3 4.7 11.4 mm 11-12 21-22	<b>LS35P30L02</b> <b>26</b> 0 4.9 10.1 24.4 mm 11-12 21-22	<b>LS35P31L02</b> <b>27</b> 0 4.9 10.1 24.4 mm 11-12 21-22	<b>LS35P32L02</b> <b>26</b> 0 4.2 8.8 21.1 mm 11-12 21-22	<b>LS35P34L02</b> <b>27</b> 0 4.2 8.8 21.1 mm 11-12 21-22
<b>LS35P13L20</b> <b>27</b> 0 2.3 11.4 mm 13-14 23-24	<b>LS35P30L20</b> <b>26</b> 0 4.9 24.4 mm 13-14 23-24	<b>LS35P31L20</b> <b>27</b> 0 4.9 24.4 mm 13-14 23-24	<b>LS35P32L20</b> <b>26</b> 0 4.2 21.1 mm 13-14 23-24	<b>LS35P34L20</b> <b>27</b> 0 4.2 21.1 mm 13-14 23-24
<b>LS35P13B02</b> <b>27</b> 0 1.4 3.3 7.8 11.2 mm 11-12 21-22 11-12 21-22	<b>LS35P30B02</b> <b>26</b> 0 3.0 7.1 16.9 24.4 mm 11-12 21-22 11-12 21-22	<b>LS35P31B02</b> <b>27</b> 0 3.0 7.1 16.9 24.4 mm 11-12 21-22 11-12 21-22	<b>LS35P32B02</b> <b>26</b> 0 2.6 6.2 14.7 21.3 mm 11-12 21-22 11-12 21-22	<b>LS35P34B02</b> <b>27</b> 0 2.6 6.2 14.7 21.3 mm 11-12 21-22 11-12 21-22
0.070	0.065	0.070	0.075	0.070

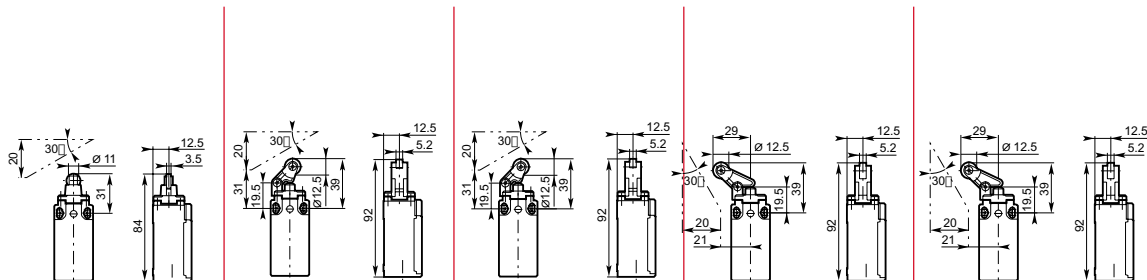

## Assembled 30mm, IP 65, UL Type 4

### Movement to be detected

#### 30° Cam translation movement

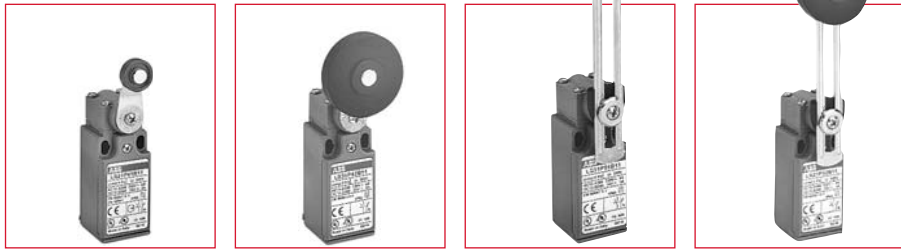

### Operating head type

	Ø 18 Polyamide roller lever	Ø 45 Rubber roller lever	Adjustable Ø 18 polyamide roller lever	Adjustable Ø 45 rubber roller lever
Conformity / (N.C. contact with positive opening operation)	EN 50 047			
Maximum actuation speed	m/s 1.5	1.5	1.5	1.5
Min. torque: - actuation	N.m 0.10	0.10	0.10	0.10
- positive opening operation	N.m 0.32	—	—	—

### 9 Additional technical data

Snap action contacts	Catalog number List price	LS35P41B11 \$ 26	LS35P42B11 \$ 27	LS35P51B11 \$ 27	LS35P52B11 \$ 28
	Operation diagram				
Non-overlapping slow action contacts	Catalog number List price	LS35P41D11 27	LS35P42D11 29	LS35P51D11 28	LS35P52D11 30
	Operation diagram				
Overlapping slow action contacts	Catalog number List price	LS35P41C11 28	LS35P42C11 30	LS35P51C11 29	LS35P52C11 30
	Operation diagram				
Slow action contacts	Catalog number List price	LS35P41L02 28	LS35P42L02 30	LS35P51L02 29	LS35P52L02 30
	Operation diagram				
Slow action contacts	Catalog number List price	LS35P41L20 28	LS35P42L20 30	LS35P51L20 29	LS35P52L20 30
	Operation diagram				
Snap action contacts	Catalog number List price	LS35P41B02 28	LS35P42B02 30	LS35P51B02 29	LS35P52B02 30
	Operation diagram				
Weight (packing per unit)	kg	0.090	0.120	0.100	0.130

### Dimensions (mm)

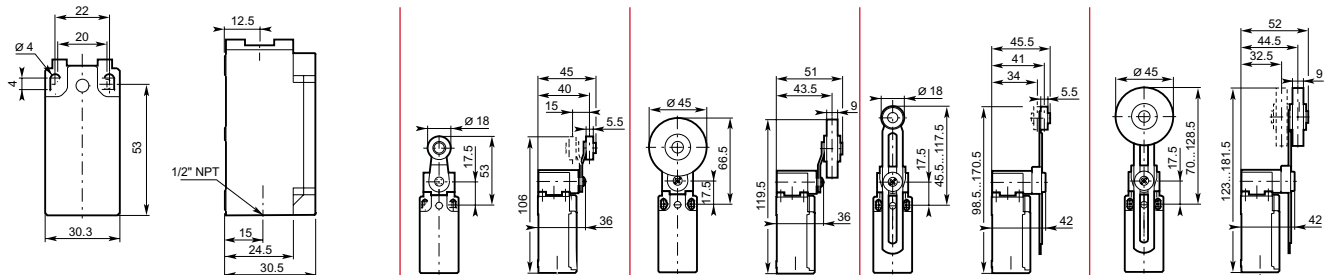



# Assembled 30mm, IP 65, UL Type 4

Plastic  
Limit switches

## Movement to be detected



## Operating head type

	Adjustable $\varnothing$ 3 stainless steel rod lever	Adjustable $\varnothing$ 3 fiber-glass rod lever	Spring rod	Flexible rod with insulated end
Conformity /  (N.C. contact with positive opening operation)				
Maximum actuation speed	m/s 1.5	m/s 1.5	m/s 1	m/s 1
Min. torque: - actuation	N.m 0.10	N.m 0.10	N.m 0.12	N.m 0.12
- positive opening operation	N.m —	N.m —	N.m —	N.m —

9

	Catalog number	LS35P71B11	LS35P72B11	LS35P91B11	LS35P92B11
Snap action contacts	List price	\$ 27	\$ 27	\$ 25	\$ 25
	Operation diagram				
Non-overlapping Slow action contacts	Catalog number	LS35P71D11	LS35P72D11	LS35P91D11	LS35P92D11
	List price	28	28	27	27
	Operation diagram				
Overlapping Slow action contacts	Catalog number	LS35P71C11	LS35P72C11	LS35P91C11	LS35P92C11
	List price	29	29	27	27
	Operation diagram				
Slow action contacts	Catalog number	LS35P71L02	LS35P72L02	LS35P91L02	LS35P92L02
	List price	29	29	27	27
	Operation diagram				
Slow action contacts	Catalog number	LS35P71L20	LS35P72L20	LS35P91L20	LS35P92L20
	List price	29	29	27	27
	Operation diagram				
Snap action contacts	Catalog number	LS35P71B02	LS35P72B02	LS35P91B02	LS35P92B02
	List price	29	29	27	27
	Operation diagram				
Weight (packing per unit)	kg	0.100	0.100	0.080	0.080

## Dimensions (mm)

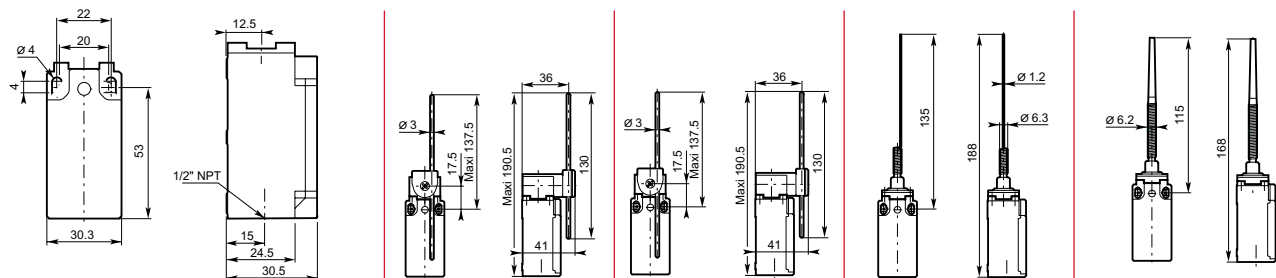

## Components

### 30mm, IP 65, UL Type 4



LS35P40B11



LSA30X41



LSC30XD11

#### Casings with contact block and angular motion head (without actuator)

	<b>LS</b>	<b>35</b>	<b>P</b>	<b>40</b>	<b>B11</b>	
Limit Switch.....	LS					
Casing width 30 mm .....		3				
<b>Cable inlet</b>						
1 cable inlet for Pg 13.5 cable gland.....		0				
1 cable inlet for Pg 11 cable gland .....		1				
1 cable inlet M16 x 1.5 for ISO 16 cable gland .....		2				
1 cable inlet M20 x 1.5 for ISO 20 cable gland .....		3				
1 cable inlet by 1/2" NPT plastic adaptor.....		5				
<b>Plastic casing</b> .....			P			
<b>Operating heads (without actuator)</b>						
With angular movement for non-adjustable roller levers .....				40		
With angular movement for adjustable roller or rod levers .....				50		
						<b>Contacts</b>
						11 .....1 N.O. + 1 N.C. contacts
						02 .....2 N.C. contacts
						20 .....2 N.O. contacts
						<b>Snap action</b>
						B .....Zb Snap
						<b>Dependent (slow) action</b>
						L .....Zb Slow / Simultaneous
						D .....Zb Non-overlapping late make
						C .....Zb Overlapping early make

#### Separate actuators (lever, key)

	<b>LS</b>	<b>A</b>	<b>30</b>	<b>X</b>	<b>41</b>	
Limit Switch.....	LS					
Actuator (lever, key) .....		A				
Casing width: 30 mm .....			30			
						<b>Reference of actuators</b>
						05, 06 .....key
						41, 42 .....non-adjustable roller lever
						51, 52 .....adjustable roller lever
						71, 72, 73, 74 .....adjustable rod lever
						<b>For casing</b>
						M .....Metal
						P .....Plastic
						X .....Plastic or metal

#### Separate contact blocks

	<b>LS</b>	<b>C</b>	<b>30</b>	<b>X</b>	<b>D</b>	<b>11</b>	
Limit Switch.....	LS						
Contact blocks .....		C					
Casing width: 30 mm .....			30				
<b>For casing:</b>							
Metal .....					M		
Plastic .....					P		
Plastic or metal .....					X		
							<b>Contacts</b>
							11 .....1 N.O. + 1 N.C. contacts
							02 .....2 N.C. contacts
							20 .....2 N.O. contacts
							<b>Snap action:</b>
							B .....Zb Snap
							<b>Dependent (slow) action:</b>
							L .....Zb Slow / Simultaneous
							D .....Zb Non-overlapping late make
							C .....Zb Overlapping early make

# Components

## 30mm, IP 65, UL Type 4

Plastic  
Limit switches

- Casings equipped with angular motion head (without actuator)
- Separate actuators
- Separate contact blocks



LSA30X42



LSA30X41 (A Shape)

Roller levers (non-adjustable)



LSA30X52



LSA30X51

Adjustable roller levers



LSA30X71

Adjustable rod levers



LSA30X72



LSA30X73



LSA30X74



LS35P40 casings equipped with angular motion head for roller levers (non-adjustable)

- ➔ LS35P40B11, LS35P40D11, LS35P40C11, LS35P40L02, LS35P40B02
- ⊗ LS35P40L20



LS30P50 ... LS35P50 casings equipped with angular motion head for adjustable roller or rod levers

- ⊗ LS35P50B11, LS35P50D11, LS35P50C11, LS35P50L02, LS35P50L20, LS35P50B02



Contact blocks

- ➔ LSC30XB11, LSC30XD11, LSC30XC11, LSC30XL02, LSC30XB02
- ⊗ LSC30XL20

➔ Suitable for positive opening operation (IEC 60947-5-1 and EN 50041).

**Warning!** The positive opening operation of limit switch is only guaranteed if the elements noted with ➔ are fitted.

## Components

### 30mm, IP 65, UL Type 4

⊖ "N.C." contact with positive opening operation or element (subassembly, head, lever) suitable for positive opening operation.

**Warning! The positive opening operation of limit switch is only guaranteed if the elements noted with ⊖ are fitted.**



LS35P40B11

#### Casings with angular motion head for non-adjustable roller levers, delivered without actuator

Contact blocks						Positive opening operation	Actuation speed max. m/s	Unit weight kg (1 pc)	Catalog number	List price
B11	D11	C11	L02	L20	B02					
1						⊖	1.5	0.092	LS35P40B11	\$ 23
	1					⊖	1.5	0.092	LS35P40D11	24
		1				⊖	1.5	0.092	LS35P40C11	25
			1			⊖	1.5	0.092	LS35P40L02	25
				1		⊗	1.5	0.092	LS35P40L20	25
					1	⊖	1.5	0.092	LS35P40B02	25

# Components

## 30mm, IP 65, UL Type 4

Plastic  
Limit switches

⊕ "N.C." contact with positive opening operation or element (subassembly, head, lever) suitable for positive opening operation.

**Warning! The positive opening operation of limit switch is only guaranteed if the elements noted with ⊕ are fitted.**



LS35P50B11



LSA30X41



LSA30X42



LSA30X51



LSA30X71



LSA30P05



LSA30P06



LSC30XD11



LSR1305

### Casings with angular motion head for adjustable rod or roller levers, delivered without actuator

Contact blocks						Positive opening operation	Actuation speed max. m/s	Unit weight kg (1 pc)	Catalog number	List price
B11	D11	C11	L02	L20	B02					
1						⊕	1.5	0.092	LS35P50B11	\$ 23
	1					⊕	1.5	0.092	LS35P50D11	24
		1				⊕	1.5	0.092	LS35P50C11	25
			1			⊕	1.5	0.092	LS35P50L02	25
				1		⊕	1.5	0.092	LS35P50L20	25
					1	⊕	1.5	0.092	LS35P50B02	25

### Actuators for LS35P40 (delivered with M3.5 screw)

#### To be actuated by 30° cam

- ⊕ 18mm polyamide roller lever ①
- ⊕ 45mm rubber roller lever ①

⊕ ⊕

— —

0.012 0.026

LSA30X41 LSA30X42

3 5

### Actuators for LS35P50 (delivered with M3.5 screw and adaptation parts)

#### To be actuated by 30° cam

- ⊕ 18mm adjustable polyamide roller lever ①
- ⊕ 45mm adjustable rubber roller lever ①

⊕ ⊕

— —

0.022 0.035

LSA30X51 LSA30X52

5 6

#### To be actuated by fully directional translation movement

- ⊕ 3mm adjustable inox rod lever, 170mm ①
- ⊕ 3mm adjustable fiberglass rod lever, 170mm ①
- ⊕ 6mm adjustable polyamide rod lever, 195mm ①
- ⊕ 6mm adjustable fiberglass rod lever, 195mm ①

⊕ ⊕ ⊕ ⊕

— — — —

0.021 0.015 0.018 0.022

LSA30X71 LSA30X72 LSA30X73 LSA30X74

5 5 5 6

### Right angle key for LS35P15

Right angle key (mounting 13mm)

⊕

—

0.013

LSA30P05

5

### Straight key for LS35P16

Straight key (mounting 13mm)

⊕

—

0.013

LSA30P06

5

### Separate contact blocks

- ⊕ 1 NC & 1 NO 2-pole snap action
- ⊕ 1 NC & 1 NO 2-pole non-overlapping slow action
- ⊕ 1 NO & 1 NC 2-pole non-overlapping slow action
- ⊕ 2 NC 2-pole simultaneous slow action
- ⊕ 2 NO 2-pole simultaneous slow action
- ⊕ 2 NC 2-pole snap action

⊕ ⊕ ⊕ ⊕ ⊕ ⊕

— — — — — —

0.025 0.025 0.025 0.025 0.025 0.025

LSC30XB11 LSC30XD11 LSC30XC11 LSC30XL02 LSC30XL20 LSC30XB02

14 14 16 16 16 16

### 1/2" NPT plastic adaptors

1 piece

—

—

0.007

LSR1305

5

① Free position adjustment of lever 10° by 10° over 360°.

## Assembled 40mm, IP 65, UL Type 4

### Movement to be detected

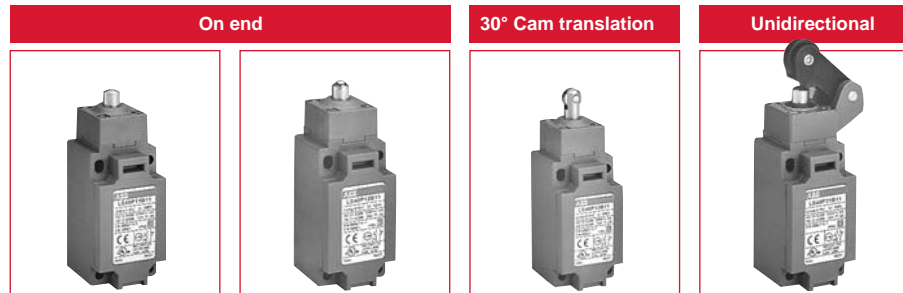

### Operating head type

	Steel plain plunger	Steel ball plunger	Steel roller plunger	Polyamide roller lever
Conformity /  (N.C. contact with positive opening operation)	EN 50 041	EN 50 041	EN 50 041	
Maximum actuation speed m/s	0.5	0.5	0.5	1
Min. force/torque:				
- actuation	22 N	22 N	16 N	12 N
- positive opening operation	66 N	66 N	48 N	40 N

### 9



	Catalog number	LS45P11B11	LS45P12B11	LS45P13B11	LS45P31B11
Snap action contacts	List price	\$ 30	\$ 32	\$ 37	\$ 34
	Operation diagram				
Non-overlapping Slow action contacts	Catalog number	LS45P11D11	LS45P12D11	LS45P13D11	LS45P31D11
List price		32	34	39	36
	Operation diagram				
Overlapping Slow action contacts	Catalog number	LS45P11C11	LS45P12C11	LS45P13C11	LS45P31C11
List price		33	35	40	37
	Operation diagram				
Slow action contacts	Catalog number	LS45P11L02	LS45P12L02	LS45P13L02	LS45P31L02
List price		33	35	40	37
	Operation diagram				
Slow action contacts	Catalog number	LS45P11L20	LS45P12L20	LS45P13L20	LS45P31L20
List price		33	35	40	37
	Operation diagram				
Snap action contacts	Catalog number	LS45P11B02	LS45P12B02	LS45P13B02	LS45P31B02
List price		33	35	40	37
	Operation diagram				
Weight (packing per unit)	kg	0.140	0.140	0.145	0.175

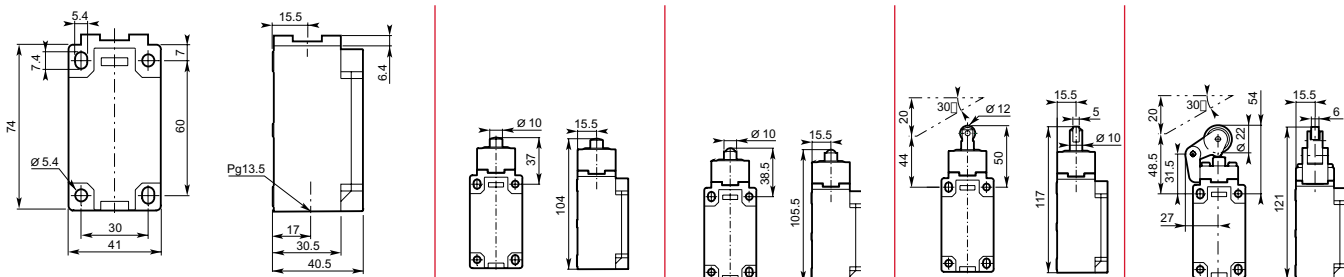







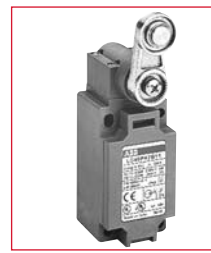
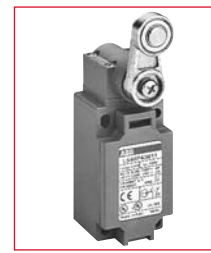
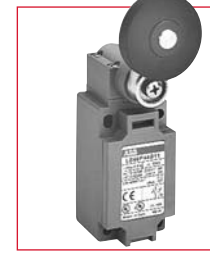

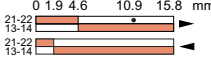
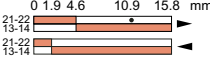
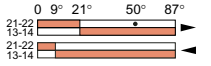
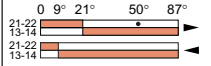
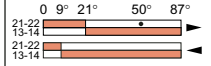
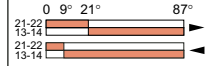
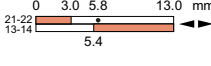
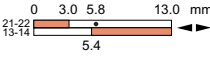
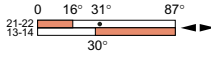
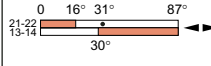
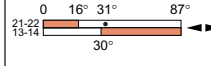
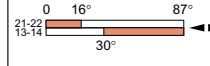
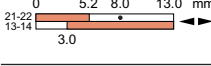
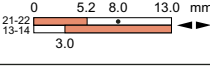
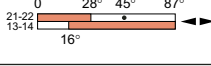
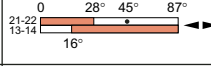
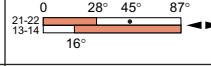
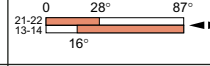
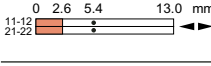
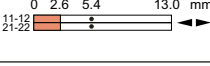
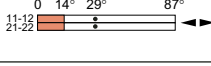
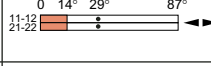
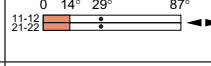
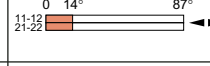
### Dimensions (mm)

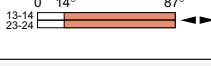

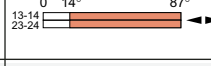
# Assembled 40mm, IP 65, UL Type 4

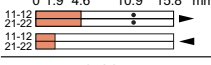
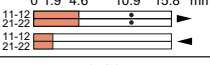
Plastic  
Limit switches

30° Cam transl.		30° Cam translation movement			
					
Stainless steel roller lever	Ball-bearing roller lever	Ø 22 Polyamide roller lever	Ø 22 Stainless steel roller lever	Ø 22 Ball-bearing roller lever	Ø 45 Rubber roller lever
1 12 N 40 N	1 12 N 40 N	EN 50 041 1.5 0.15 N.m 0.44 N.m	EN 50 041 1.5 0.15 N.m 0.44 N.m	EN 50 041 1.5 0.15 N.m 0.44 N.m	1.5 0.15 N.m -

LS45P32B11 \$ 39	LS45P33B11 \$ 36	LS45P41B11 \$ 39	LS45P42B11 \$ 47	LS45P43B11 \$ 42	LS45P44B11 \$ 41
					
LS45P32D11 42	LS45P33D11 38	LS45P41D11 42	LS45P42D11 50	LS45P43D11 45	LS45P44D11 44
					
LS45P32C11 43	LS45P33C11 39	LS45P41C11 43	LS45P42C11 52	LS45P43C11 47	LS45P44C11 45
					
LS45P32L02 43	LS45P33L02 39	LS45P41L02 43	LS45P42L02 52	LS45P43L02 47	LS45P44L02 45
					
LS45P32L20 43	LS45P33L20 39	LS45P41L20 43	LS45P42L20 52	LS45P43L20 47	LS45P44L20 45
					
LS45P32B02 43	LS45P33B02 39	LS45P41B02 43	LS45P42B02 52	LS45P43B02 47	LS45P44B02 45
					
0.185	0.185	0.185	0.195	0.195	0.205

## Dimensions (in mm)

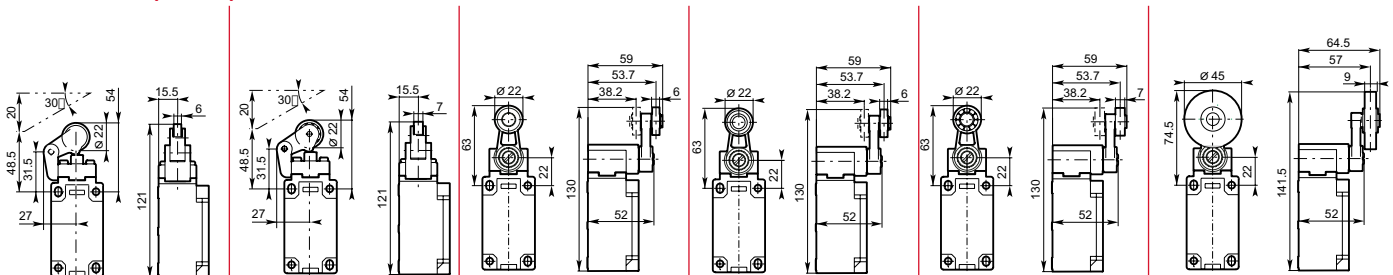

## Assembled 40mm, IP 65, UL Type 4

Movement to be detected

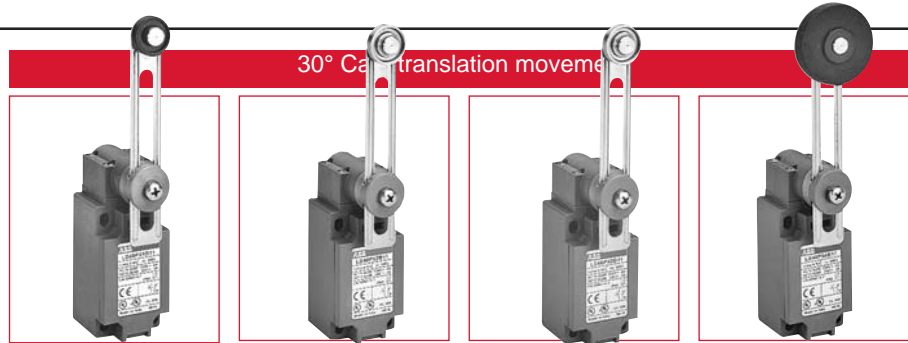

Operating head Catalog number

	Adjustable Ø 22 polyamide roller lever	Adjustable Ø 22 stainless steel roller lever	Adjustable Ø 22 stainless steel ball-bearing roller lever	Adjustable Ø 45 rubber roller lever
Conformity / (N.C. contact with positive opening operation)	☑	☑	☑	☑
Maximum actuation speed	m/s 1.5	m/s 1.5	m/s 1.5	m/s 1.5
Min. torque: - actuation	N.m 0.15	N.m 0.15	N.m 0.15	N.m 0.15
- positive opening operation	N.m —	N.m —	N.m —	N.m —

9

		LS45P51B11 \$ 39	LS45P52B11 \$ 47	LS45P53B11 \$ 43	LS45P54B11 \$ 41
Snap action contacts	Catalog number List price	LS45P51B11 \$ 39	LS45P52B11 \$ 47	LS45P53B11 \$ 43	LS45P54B11 \$ 41
	Operation diagram				
Non-overlapping Slow action contacts	Catalog number List price	LS45P51D11 42	LS45P52D11 50	LS45P53D11 46	LS45P54D11 44
	Operation diagram				
Overlapping Slow action contacts	Catalog number List price	LS45P51C11 43	LS45P52C11 52	LS45P53C11 47	LS45P54C11 45
	Operation diagram				
Slow action contacts	Catalog number List price	LS45P51L02 43	LS45P52L02 52	LS45P53L02 47	LS45P54L02 45
	Operation diagram				
Slow action contacts	Catalog number List price	LS45P51L20 43	LS45P52L20 52	LS45P53L20 47	LS45P54L20 45
	Operation diagram				
Snap action contacts	Catalog number List price	LS45P51B02 43	LS45P52B02 52	LS45P53B02 47	LS45P54B02 45
	Operation diagram				
Weight (packing per unit)	kg	0.190	0.200	0.200	0.200

Dimensions (in mm)

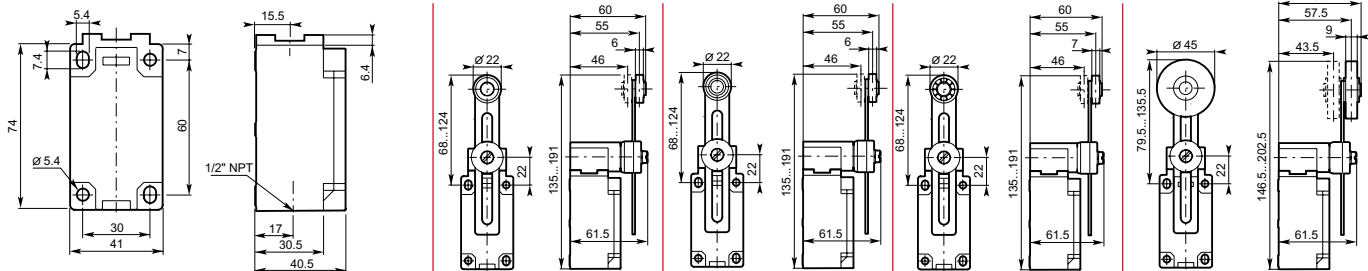



# Assembled 40mm, IP 65, UL Type 4

Plastic  
Limit switches

## Movement to be detected

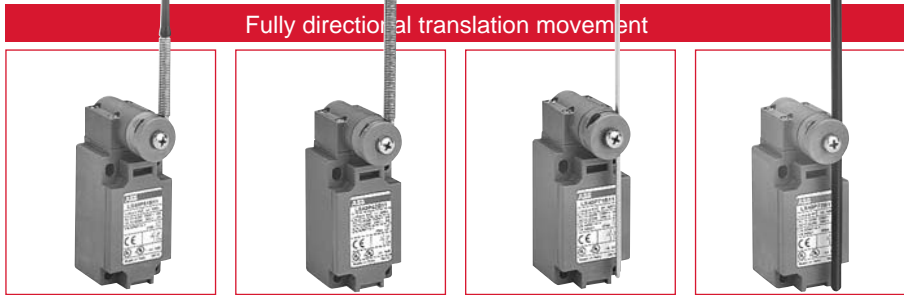

## Operating head type

	Flexible lever with insulated end	Coil spring lever	Adjustable Ø 3 stainless steel rod lever	Adjustable ø 6 polyamide rod lever
Conformity /  (N.C. contact with positive opening operation)			EN 50 041	EN 50 041
Maximum actuation speed	m/s	1.5	1.5	1.5
Min. torque: - actuation	N.m	0.15	0.15	0.15
- positive opening operation	N.m	-	-	-

Snap action contacts	Catalog number	LS45P61B11	LS45P62B11	LS45P71B11	LS45P72B11
	List price	\$ 41	\$ 41	\$ 38	\$ 38
	Operation diagram				
Non-overlapping Slow action contacts	Catalog number	LS45P61D11	LS45P62D11	LS45P71D11	LS45P72D11
	List price	44	44	41	41
	Operation diagram				
Overlapping Slow action contacts	Catalog number	LS45P61C11	LS45P62C11	LS45P71C11	LS45P72C11
	List price	46	45	43	42
	Operation diagram				
Slow action contacts	Catalog number	LS45P61L02	LS45P62L02	LS45P71L02	LS45P72L02
	List price	46	45	43	42
	Operation diagram				
Slow action contacts	Catalog number	LS45P61L20	LS45P62L20	LS45P71L20	LS45P72L20
	List price	46	45	43	42
	Operation diagram				
Snap action contacts	Catalog number	LS45P61B02	LS45P62B02	LS45P71B02	LS45P72B02
	List price	46	45	43	42
	Operation diagram				
Weight (packing per unit)	kg	0.190	0.190	0.185	0.185

## Dimensions (in mm)

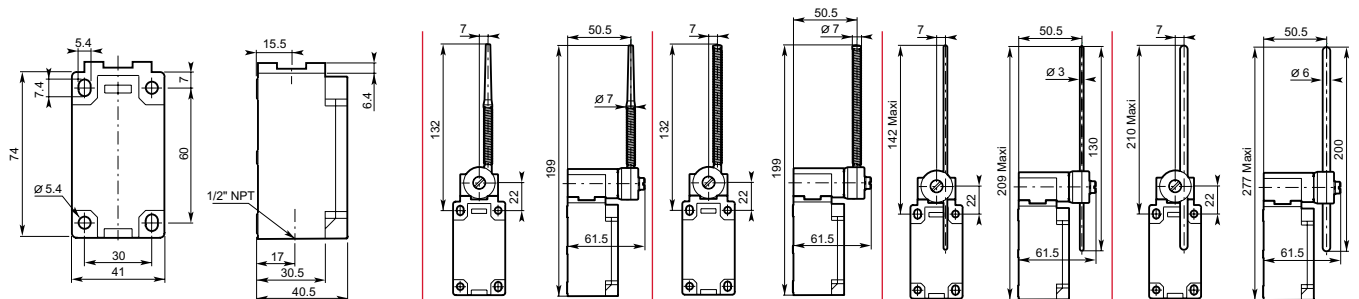

## Assembled 40mm, IP 65, UL Type 4

### Movement to be detected

### Multidirectional

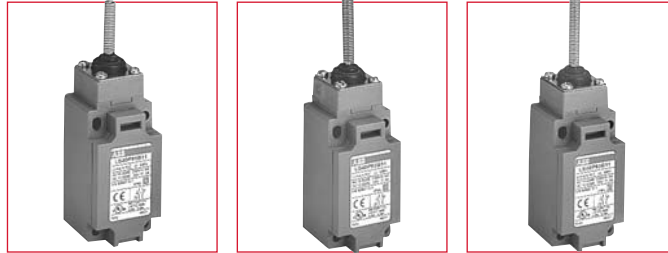

### Operating head type

	Spring rod	Flexible rod with insulated end	Coil spring rod
Conformity / $\odot$ (N.C. contact with positive opening operation)	<input type="checkbox"/>	<input type="checkbox"/>	<input type="checkbox"/>
Maximum actuation speed	1	1	1
Min. torque: - actuation	0.18	0.18	0.18
- positive opening operation	-	-	-

9

	Catalog number	LS45P91B11	LS45P92B11	LS45P93B11
Snap action contacts	List price	\$ 32	\$ 35	\$ 33
	Operation diagram			
Non-overlapping Slow action contacts	Catalog number	LS45P91D11	LS45P92D11	LS45P93D11
List price	34	37	35	
	Operation diagram			
Overlapping Slow action contacts	Catalog number	LS45P91C11	LS45P92C11	LS45P93C11
List price	35	38	37	
	Operation diagram			
Slow action contacts	Catalog number	LS45P91L02	LS45P92L02	LS45P93L02
List price	35	38	37	
	Operation diagram			
Slow action contacts	Catalog number	LS45P91L20	LS45P92L20	LS45P93L20
List price	35	38	37	
	Operation diagram			
Snap action contacts	Catalog number	LS45P91B02	LS45P92B02	LS45P93B02
List price	35	38	37	
	Operation diagram			
Weight (packing per unit)	kg	0.135	0.140	0.145

### Dimensions (in mm)

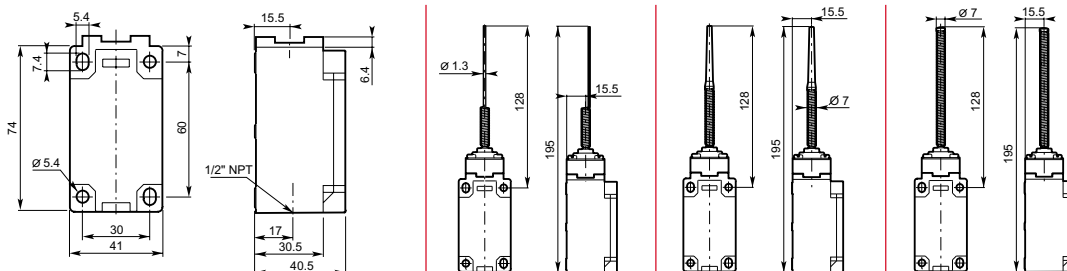

# Components

## 40mm, IP 65, UL Type 4



### Bodies with contact block for rectilinear or angular motion heads

	<b>LS</b>	<b>45</b>	<b>P</b>	<b>00</b>	<b>B 11</b>	
Limit Switch.....	LS					<b>Contacts</b>
Casing width 40 mm .....		3				<b>11</b> ..... 1 N.O. + 1 N.C. contacts
<b>Cable inlet</b>						<b>02</b> ..... 2 N.C. contacts
1 cable inlet for Pg 13.5 cable gland.....						<b>20</b> ..... 2 N.O. contacts
1 cable inlet M20 x 1.5 for ISO 20 cable gland.....						
1 cable inlet for 1/2" NPT .....						
Plastic casing.....			P			<b>Snap action</b>
Without operating head .....				00		<b>B</b> .....Zb Snap
						<b>Dependent (slow) action</b>
						<b>L</b> .....Zb Slow / Simultaneous
						<b>D</b> .....Zb Non-overlapping late make
						<b>C</b> .....Zb Overlapping early make

### Operating heads

	<b>LS</b>	<b>T</b>	<b>H</b>	<b>41</b>	
Limit Switch.....	LS				<b>References of heads</b>
Operating head .....		T			<b>11 ... 14, 19</b> ... with rectilinear movement (plain plunger, steel ball plunger or roller plunger)
For plastic casing 40 mm width .....				40	<b>31 ... 37</b> ..... with rectilinear movement (roller lever on steel plunger)
					<b>40</b> ..... with angular movement (without actuator) actuator to be ordered separately
					<b>41 ... 44</b> ..... with angular movement (roller lever)
					<b>50</b> ..... with angular movement (without actuator) actuator to be ordered separately
					<b>51 ... 54</b> ..... with angular movement (adjustable roller lever)
					<b>61, 62</b> ..... flexible lever (spring)
					<b>71, 72, 73</b> ..... adjustable lever (rod)
					<b>91 ... 93</b> ..... multidirectional angular movement (spring rod)

### Separate actuators (roller lever, adjustable roller or rod levers, etc.)

	<b>LS</b>	<b>A</b>	<b>40</b>	<b>X</b>	<b>51</b>	
Limit Switch.....	LS					<b>Reference of actuators</b>
Actuator (roller) .....		A				<b>41 ... 44</b> .....non-adjustable roller lever
Casing width: 40 mm .....			40			<b>51 ... 54</b> .....adjustable roller lever
						<b>61, 62</b> .....flexible lever (spring)
						<b>71, 72, 73</b> .....adjustable lever (rod)
						<b>For casing</b>
						<b>M</b> ..... Metal
						<b>P</b> ..... Plastic
						<b>X</b> ..... Plastic or metal

### Separate contact blocks

	<b>LS</b>	<b>C</b>	<b>40</b>	<b>X</b>	<b>C</b>	<b>11</b>	
Limit Switch.....	LS						<b>Contacts</b>
Contact blocks .....		C					<b>11</b> ..... 1 N.O. + 1 N.C. contacts
Casing width: 40 mm .....			40				<b>02</b> ..... 2 N.C. contacts
							<b>20</b> ..... 2 N.O. contacts
<b>For casing</b>							Snap action:
Metal .....					M		<b>B</b> .....Zb Snap
Plastic .....					P		Dependent (slow) action:
Plastic or metal .....					X		<b>L</b> .....Zb Slow / Simultaneous
							<b>D</b> .....Zb Non-overlapping late make
							<b>C</b> .....Zb Overlapping early make

## Components

40mm, IP 65, UL Type 4

- Bodies with contact block
- Operating heads with actuator

9

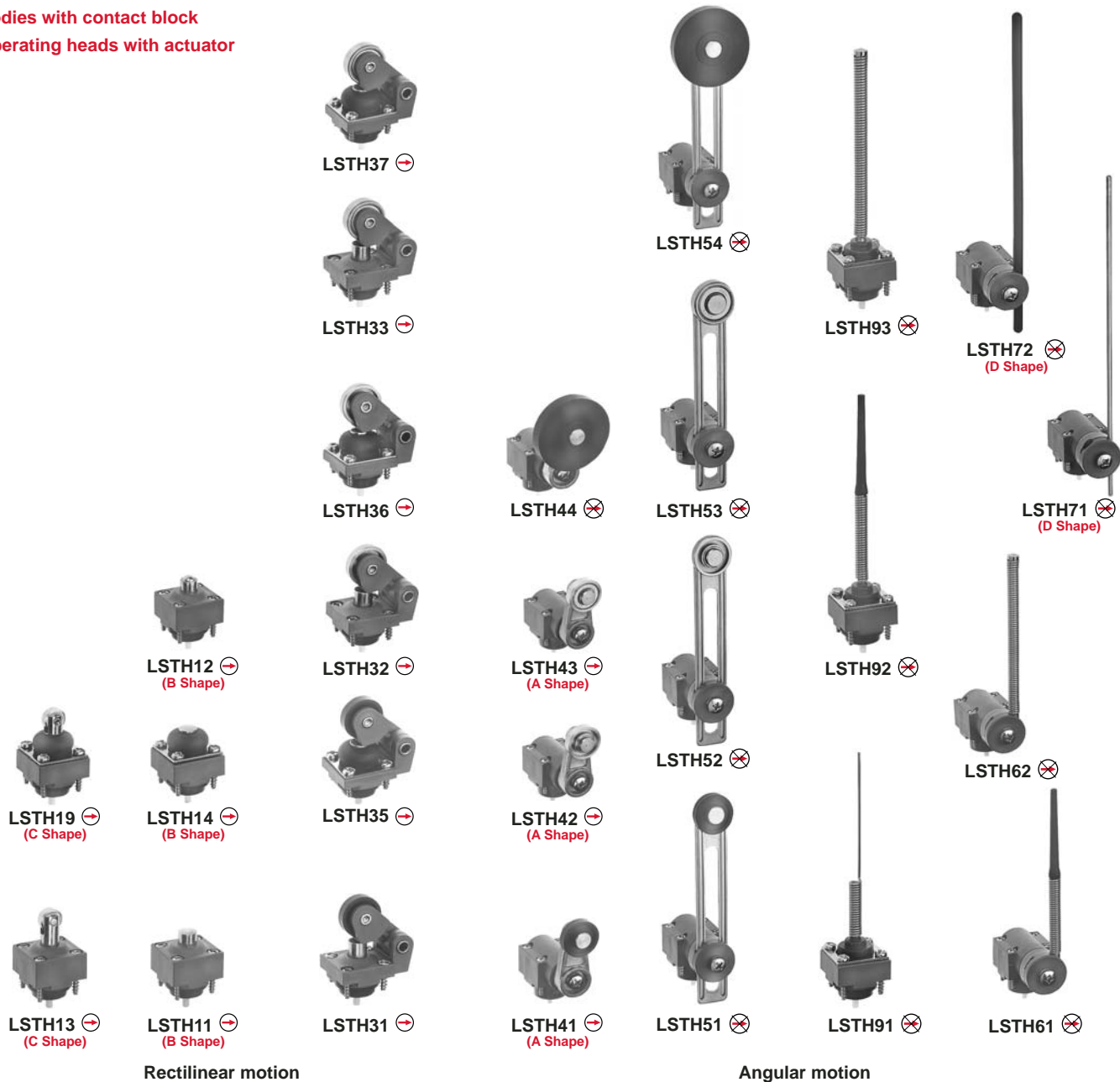

Rectilinear motion

Angular motion

### LSTH... rectilinear motion heads

- To be actuated from end.  
With plunger (plain or with ball): LSTH11, LSTH12 and LSTH14.
- To be actuated by 30° cam translation.  
With roller plunger: LSTH13, LSTH19.
- To be actuated unidirectionally by 30° cam translation.  
With roller lever on steel plunger: LSTH31 ... LSTH37.

### LSTH... angular motion heads

- To be actuated by 30° cam translation.  
With roller lever: LSTH41 ... LSTH54.
- To be actuated by fully directional translation movement.  
With rod or spring lever: LSTH61 ... LSTH72.
- To be actuated multidirectionally.  
With spring rod: LSTH91 ... LSTH93.



### Bodies with contact block

➔ LS45P00B11, LS45P00D11, LS45P00C11, LS45P00L02, LS45P00B02

⊗ LS45P00L20

Suitable for positive opening operation (IEC 60947-5-1 and EN 50041).

**Warning!** The positive opening operation of limit switch is only guaranteed if the elements noted with ➔ are fitted.

# Components

## 40mm, IP 65, UL Type 4

Plastic  
Limit switches

- Bodies with contact block
- Angular motion heads (without actuator)
- Separate actuators
- Separate contact blocks

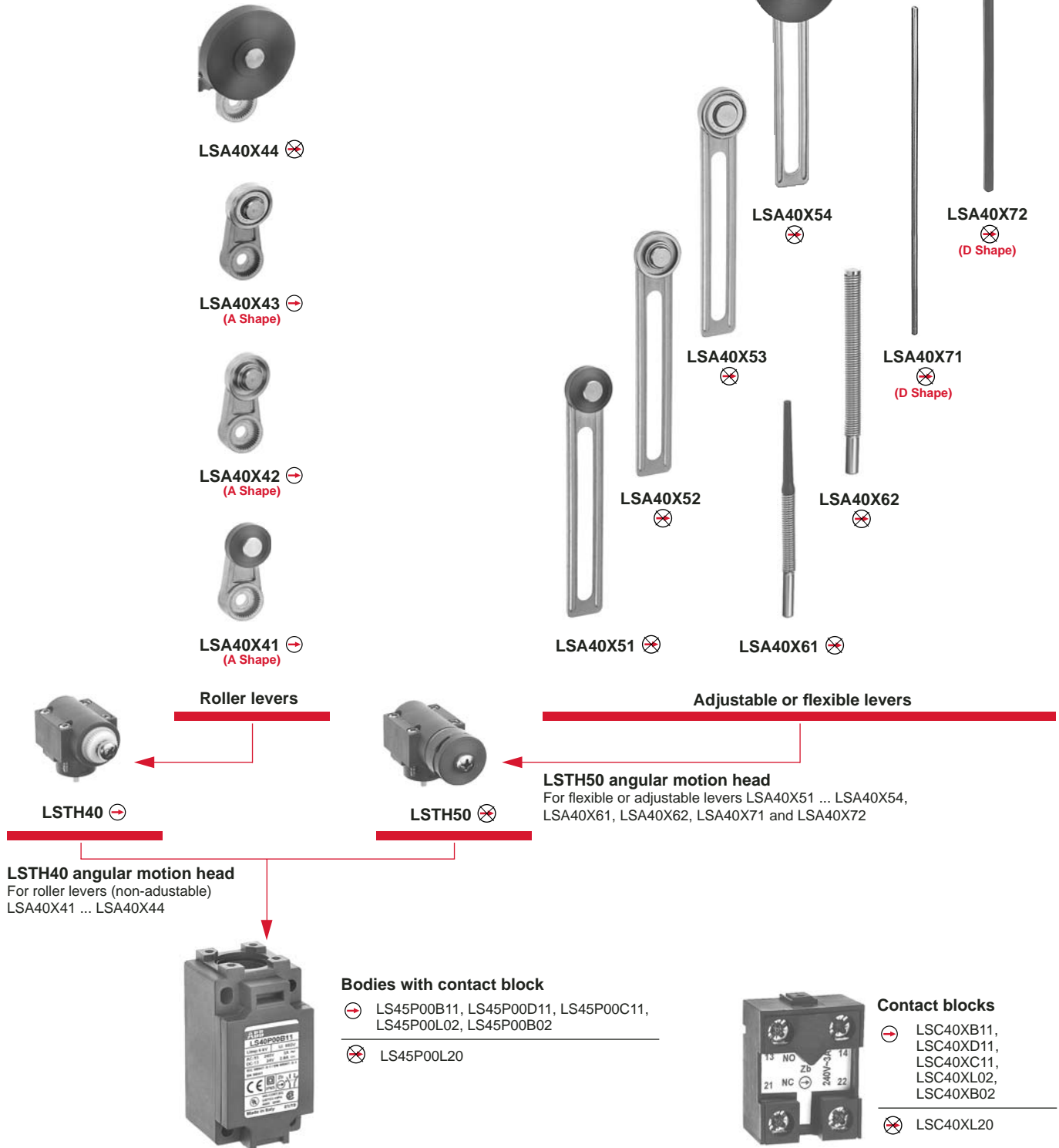

9

⊕ : Suitable for positive opening operation (IEC 60947-5-1 and EN 50041)  
**Warning!** The positive opening operation of limit switch is only guaranteed if the elements noted with ⊕ are fitted.

## Components

### 40mm, IP 65, UL Type 4

⊕ "N.C." contact with positive opening operation or element (subassembly, head, lever) suitable for positive opening operation.

**Warning!** The positive opening operation of limit switch is only guaranteed if the elements noted with ⊕ are fitted.



LS45P00B11



LSTH11



LSTH19



LSTH31



LSTH37

#### Bodies with contact block for rectilinear or angular motion heads

Contact blocks						Positive opening operation	Actuation speed max. m/s	Unit weight kg (1 pc)	Catalog number	List price
B11	D11	C11	L02	L20	B02					
1						⊕	—	0.108	LS45P00B11	\$ 23
	1					⊕	—	0.108	LS45P00D11	24
		1				⊕	—	0.108	LS45P00C11	25
			1			⊕	—	0.108	LS45P00L02	25
				1		⊗	—	0.108	LS45P00L20	25
					1	⊕	—	0.108	LS45P00B02	25

#### Rectilinear motion heads with actuator

##### To be actuated by end

Steel plain plunger (zinc-plated)	⊕	0.5	0.042	LSTH11	9
Steel plain plunger (zinc-plated) and dust protection cup	⊕	0.5	0.043	LSTH14	12
Steel ball plunger	⊕	0.5	0.042	LSTH12	11

##### To be actuated by 30° cam

Steel roller plunger (zinc-plated)	⊕	0.5	0.048	LSTH13	16
Steel roller plunger (zinc-plated) and dust protection cup	⊕	0.5	0.048	LSTH19	19

##### To be actuated unidirectionally by 30° cam

∅ 22mm polyamide roller lever on steel plunger (zinc-plated)	⊕	1.5	0.046	LSTH31	15
∅ 22mm polyamide roller lever on steel plunger (zinc-plated) & dust protection cup	⊕	1.5	0.049	LSTH35	18
∅ 22mm stainless steel roller lever on steel plunger (zinc-plated)	⊕	1.5	0.055	LSTH32	20
∅ 22mm stainless steel roller lever on steel plunger (zinc-plated) & dust protection cup	⊕	1.5	0.058	LSTH36	23
∅ 22mm steel ball-bearing roller lever on steel plunger (zinc-plated)	⊕	1.5	0.057	LSTH33	17
∅ 22mm steel ball-bearing roller lever on steel plunger (zinc-plated) & dust protection cup	⊕	1.5	0.060	LSTH37	20

# Components

## 40mm, IP 65, UL Type 4

Plastic  
Limit switches

⊕ "N.C." contact with positive opening operation or element (subassembly, head, lever) suitable for positive opening operation.

**Warning! The positive opening operation of limit switch is only guaranteed if the elements noted with ⊕ are fitted.**



LSTH41



LSTH51



LSTH92



LSTH40



LSA40X41



LSA40X43

### Bodies with contact block for rectilinear or angular motion heads

Contact blocks	Positive opening operation	Actuation speed max. m/s	Unit weight kg (1 pc)	Catalog number	List price
<b>Angular motion heads with actuator</b>					
<b>To be actuated by 30° cam</b>					
∅ 22mm polyamide roller lever ①	⊕	1.5	0.082	LSTH41	\$ 20
∅ 22mm stainless steel roller lever ①	⊕	1.5	0.091	LSTH42	28
∅ 22mm steel ball-bearing roller lever ①	⊕	1.5	0.093	LSTH43	23
∅ 45mm rubber roller lever ①	⊗	1.5	0.098	LSTH44	22
∅ 22mm adjustable polyamide roller lever ①	⊗	1.5	0.088	LSTH51	20
∅ 22mm adjustable stainless steel roller lever ①	⊗	1.5	0.098	LSTH52	28
∅ 22mm adjustable steel ball-bearing roller lever ①	⊗	1.5	0.100	LSTH53	24
∅ 45mm adjustable rubber roller lever ①	⊗	1.5	0.105	LSTH54	22
<b>To be actuated by fully directional translation movement</b>					
Stainless steel flexible lever with insulated end ①	⊗	1	0.083	LSTH61	22
Stainless steel coil spring lever ①	⊗	1	0.089	LSTH62	22
∅ 3mm adjustable stainless steel rod lever, 195mm ①	⊗	1	0.087	LSTH71	19
∅ 6mm adjustable polyamide rod lever, 195mm ①	⊗	1	0.083	LSTH72	19
∅ 6mm adjustable fiberglass rod lever, 195mm ①	⊗	1	0.087	LSTH73	20
<b>Multidirectional angular motion heads (to be actuated by fully directional translation movement)</b>					
Stainless steel spring rod	⊗	1	0.046	LSTH91	13
Stainless steel flexible rod with insulated end	⊗	1	0.049	LSTH92	16
Stainless steel coil spring rod	⊗	1	0.055	LSTH93	14
<b>Angular motion head without actuator for non-adjustable roller levers (delivered with M5 screw and washer)</b>					
	⊕	1.5	0.050	LSTH40	14
<b>Actuators for angular motion head LSTH40</b>					
∅ 22mm polyamide roller lever ①	⊕	—	0.032	LSA40X41	6
∅ 22mm stainless steel roller lever ①	⊕	—	0.042	LSA40X42	14
∅ 22mm steel ball-bearing roller lever ①	⊕	—	0.044	LSA40X43	9
∅ 45mm rubber roller lever ①	⊗	—	0.050	LSA40X44	8

① Free position adjustment of lever 9° by 9° over 360°.

## Components

### 40mm, IP 65, UL Type 4

⊖ "N.C." contact with positive opening operation or element (subassembly, head, lever) suitable for positive opening operation.

**Warning! The positive opening operation of limit switch is only guaranteed if the elements noted with ⊖ are fitted.**



LSTH50



LSA40X72



LSA40X51



LSC40XB11

	Positive opening operation	Actuation speed max. m/s	Unit weight kg (1 pc)	Catalog number	List price
<b>Angular motion head without actuator, for flexible or adjustable levers</b> (delivered with M5 screw, washer & adaptation parts)					
	⊖	—	0.058	LSTH50	\$ 15
<b>Actuators for angular motion head LSTH50</b>					
∅ 22mm adjustable polyamide roller lever ①	⊖	—	0.023	LSA40X51	5
∅ 22mm adjustable stainless steel roller lever ①	⊖	—	0.032	LSA40X52	13
∅ 22mm adjustable steel ball-bearing roller lever ①	⊖	—	0.034	LSA40X53	9
∅ 45mm adjustable rubber roller lever ①	⊖	—	0.039	LSA40X54	7
Stainless steel flexible lever with insulated end ①	⊖	—	0.017	LSA40X61	7
Stainless steel coil spring lever ①	⊖	—	0.023	LSA40X62	7
∅ 3mm adjustable stainless steel rod lever, 195mm ①	⊖	—	0.014	LSA40X71	4
∅ 6mm adjustable polyamide rod lever, 195mm ①	⊖	—	0.010	LSA40X72	4
∅ 6mm adjustable fiberglass rod lever, 195mm ①	⊖	—	0.014	LSA40X73	5
<b>Contact blocks (with adaptor)</b>					
1 NC & 1 NO 2-pole snap action	⊖	—	0.032	LSC40XB11	15
1 NC & 1 NO 2-pole non-overlapping slow action	⊖	—	0.032	LSC40XD11	15
1 NO & 1 NC 2-pole overlapping slow action	⊖	—	0.032	LSC40XC11	17
2 NC 2-pole simultaneous slow action	⊖	—	0.032	LSC40XL02	17
2 NO 2-pole simultaneous slow action	⊖	—	0.032	LSC40XL20	17
2 NC 2-pole snap action	⊖	—	0.032	LSC40XB02	17

① Free position adjustment of lever 9° by 9° over 360°.



# Technical data

## IP 65, UL Type 4



### General technical data

Standards	Devices conform with international IEC 947-5-1 and European EN 60 947-5-1 standards	
Certifications - Approvals	UL & CSA	
Air temperature near the device (IEC)	°C	- 25 ... + 70
- during operation		- 30 ... + 80
- for storage	°C	
Climatic withstand	According to IEC 68-2-3 and salty mist according to IEC 68-2-11	
Mounting positions	All positions are authorized	
Shock withstand (according to IEC 68-2-27 and EN 60 068-2-27)	50g <sup>Ⓢ</sup> (1/2 sinusoidal shock for 11 ms) no change in contact position	
Resistance to vibrations (acc. to IEC 68-2-6 and EN 60 068-2-6)	25g (10 – 500 Hz) no change in position of contacts greater than 100 μs	
Protection against electrical shocks (acc. to IEC 536)	Class II	
Degree of protection	UL Type 4 & IP 65	
Consistency (measured over 1 million operations)	0.1 mm (upon closing point)	
Minimum actuation speed	m/s	Slow action contacts 0.060 / Snap action contacts 0.001

### Electrical Data

<b>Rated insulation voltage U<sub>i</sub></b> - according to IEC 947-1 and EN 60-947-1 - according to UL 508 and CSA C22-2 n° 14	500 V (degree of pollution 3) A 600, Q 600												
Rated impulse withstand voltage U <sub>imp</sub> (according to IEC 947-1 and EN 60 947-1)	kV	6											
Conventional free air thermal current I <sub>th</sub> (according to IEC 947-5-1) q ≤ 40 °C	A	10											
Short-circuit protection U <sub>o</sub> ≤ 500 V a.c. - gG (gl) type fuses	A	10											
Rated operational current I <sub>o</sub> / AC-15 (according to IEC 947-5-1)	24 V - 50/60 Hz A 130 V - 50/60 Hz A 230 V - 50/60 Hz A 240 V - 50/60 Hz A 400 V - 50/60 Hz A	10 5.5 3.1 3 1.8											
I <sub>o</sub> / DC-13 (according to IEC 947-5-1)	24 V - d.c. A 110 V - d.c. A 250 V - d.c. A	2.8 0.6 0.27											
Switching frequency	Cycles/h	3600											
Load factor		0.5											
Resistance between contacts	mW	25											
Connecting terminals	M3.5 (+, -) pozidriv 2 screw with cable clamp												
Terminal for protective conductor	- M3.5 (+, -) pozidriv 2 screw with cable clamp												
Connecting capacity	1 or 2 x mm <sup>2</sup>	0.5 ... 2.5											
Terminal marking	According to EN 50 013												
Mechanical durability	Millions of operations	<table border="0"> <tr> <td>15</td> <td rowspan="5">} LS</td> <td rowspan="5">} 30</td> <td rowspan="5">} P</td> <td>10 – 12; 30 – 34</td> </tr> <tr> <td>10</td> <td>13; 41 – 44; 51 – 54; 61 – 72</td> </tr> <tr> <td>5</td> <td>91 – 93</td> </tr> <tr> <td>&gt; 1</td> <td>15; 16</td> </tr> </table>	15	} LS	} 30	} P	10 – 12; 30 – 34	10	13; 41 – 44; 51 – 54; 61 – 72	5	91 – 93	> 1	15; 16
15	} LS	} 30	} P				10 – 12; 30 – 34						
10							13; 41 – 44; 51 – 54; 61 – 72						
5							91 – 93						
> 1							15; 16						
Electrical durability (according to IEC 947-5-1)				Utilization categories AC-15 and DC-13 (Load factor of 0.5 according to curves below)									

9

### AC-15 — Snap action

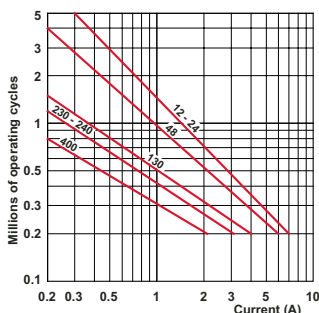

### AC-15 — Slow action

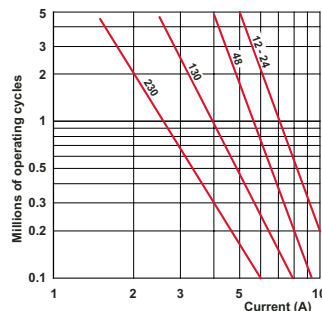

DC-13	Snap action		Slow action	
	Power breaking for a durability of 5 million operating cycles			
Voltage	24 V	9.5 W	12 W	
Voltage	48 V	6.8 W	9 W	
Voltage	110 V	3.6 W	6 W	

Ⓢ except for LS30/31/35 (P42): 25g

### Double insulation

Class II materials, according to IEC 536, are designed with double insulation. This measure consists in doubling the functional insulation with an additional layer of insulation so as to eliminate the risk of electric shock and thus not having to protect elsewhere. No conductive part of "double insulated" material should be connected to a protective conductor.

### Positive opening operation

A control switch, with one or more break-contact elements, has a positive opening operation when the switch actuator ensures full contact opening of the break-contact. For the part of travel that separates the contacts, there must be a positive drive, with no resilient member (e.g. springs), between the moving contacts and the point of the actuator to which the actuating force is applied.

The positive opening operation does not deal with N.O. contacts.

Control switches with positive opening operation may be provided with either snap action or slow action contact elements. To use several contacts on the same control switch with positive opening operation, they must be electrically separated from each other, if not, only one may be used.

Every control switch with positive opening operation must be indelibly marked on the outside with the symbol: 

### Snap action

Snap action contacts are characterized by a release position that is distinct from the operating position (differential travel). Snap breaking of moving contacts is independent of the switch actuator's speed and contributes to regular electric performance even for slow switch actuator speeds.

9

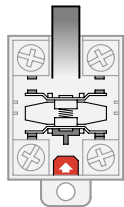

State of rest

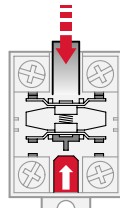

Contact change

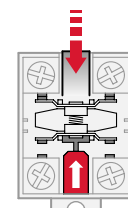

Positive opening

### Slow action

Slow action contacts are characterized by a release position that is the same as the operating position. The switch actuator's speed directly conditions the travel speed of contacts.

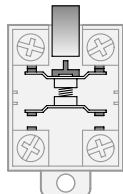

State of rest

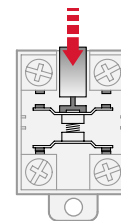

Completely closed

### Contact shape according to IEC 947-5-1.

Change-over contact elements with 4 terminals must be indelibly marked with the corresponding **Za** or **Zb** symbol as in the diagrams below.

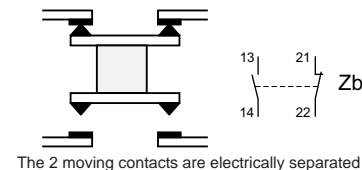
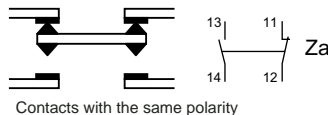

### Utilization category

AC-15: switching of electromagnetic loads of electromagnets using an alternating current (>72 VA).

DC-13: switching of electromagnets using a direct current.

### Terminals

Limit switches with metal casings must have a terminal, for a protective conductor, that is placed inside the casing very close to the cable inlet and must be indelibly marked.

### Minimum actuation force/torque

The minimum amount of force/torque that is to be applied to the switch actuator to produce a change in contact position.

### Minimum force/torque to achieve positive opening operation

The minimum amount of force/torque that is to be applied to the switch actuator to ensure positive opening operation of the N.C. contact.

# Technical data

## Travel and operation diagrams

Plastic  
Limit switches

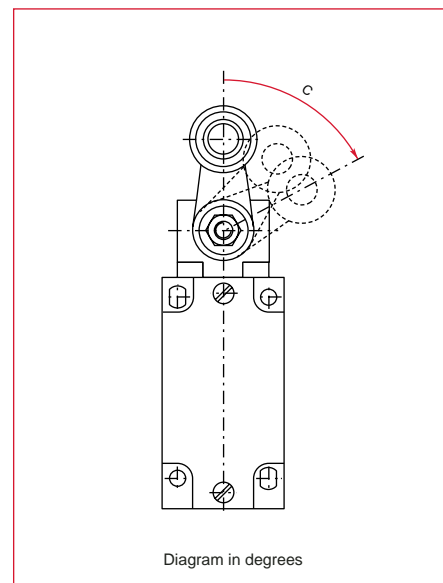
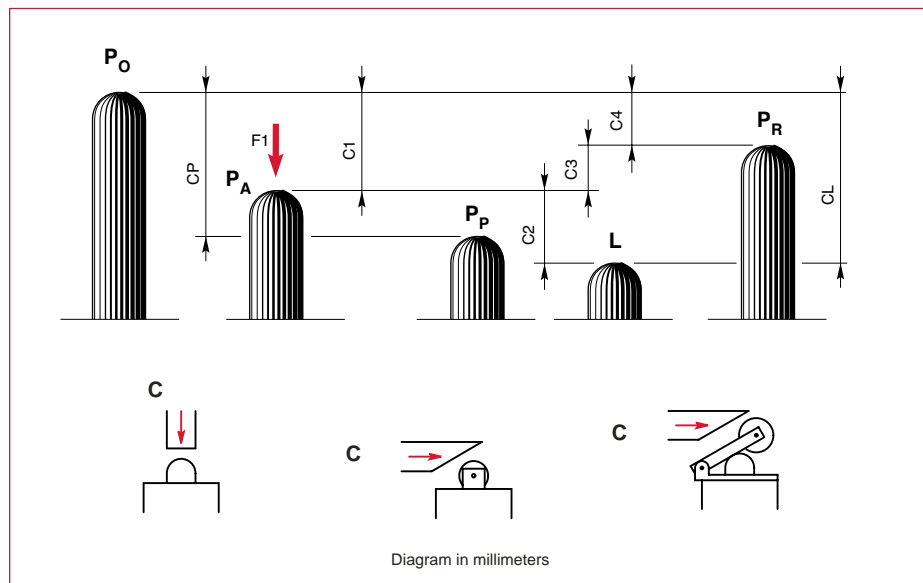

9

**P<sub>0</sub> Free position**

Position of the switch actuator when no external force is exerted on it.

**P<sub>A</sub> Operating position**

Position of the switch actuator, under the effect of force F<sub>1</sub>, when the contacts leave their initial free position.

**P<sub>P</sub> Positive opening position**

Position of the switch actuator from which positive opening is ensured.

**L Max. travel position**

Maximum acceptable travel position of the switch actuator under the effect of a force F<sub>1</sub>.

**P<sub>R</sub> Release position**

Position of the switch actuator when the contacts return to their initial free position.

**C<sub>1</sub> Pre-travel**

Distance between the free position P<sub>0</sub> and the operating position P<sub>A</sub>.

**C<sub>P</sub> Positive opening travel**

Minimum travel of the switch actuator, from the free position, to ensure positive opening operation of the normally closed contact.

**C<sub>2</sub> Over-travel**

Distance between the operating position P<sub>A</sub> and the max. travel position L.

**C<sub>L</sub> Max. travel**

Distance between the free position P<sub>0</sub> and the max. travel position L.

**C<sub>3</sub> Differential travel (C<sub>1</sub>-C<sub>4</sub>)**

Travel difference of the switch actuator between the operating position P<sub>A</sub> and the release position P<sub>R</sub>.

**C<sub>4</sub> Release travel**

Distance between the release position P<sub>R</sub> and the free position P<sub>0</sub>.

**Diagram for snap action contacts:**

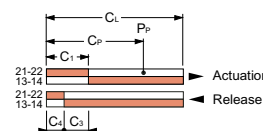

**Diagram for non-overlapping slow action contacts:**

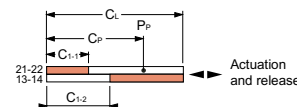

**Note:** for slow action contacts, C<sub>3</sub> = 0, C<sub>1-1</sub> = pre-travel of contact 21-22, C<sub>1-2</sub> = pre-travel of contact 13-14.

**Examples:**

LS45M13B11  
(snap action contacts)

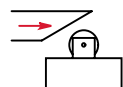
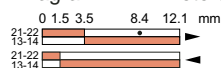

Diagram in millimeters/cam travel



LS45M41B11  
(snap action contacts)

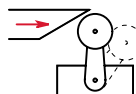
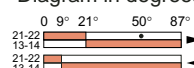

Diagram in degrees/lever rotation



LS45M11D11  
(non-overlapping slow action contacts)

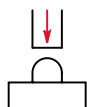
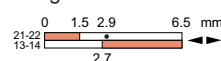
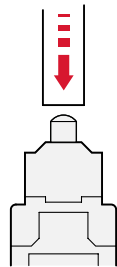

Diagram in millimeters/plunger travel



## Technical data Utilization precautions

### Plain plunger



Correct

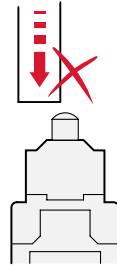

Incorrect

### Roller plunger or roller lever

9

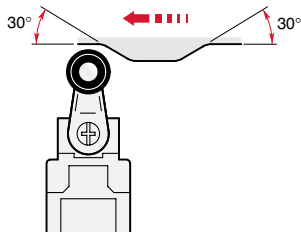

Correct

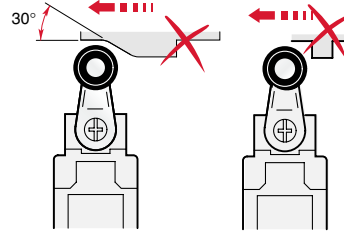

Incorrect

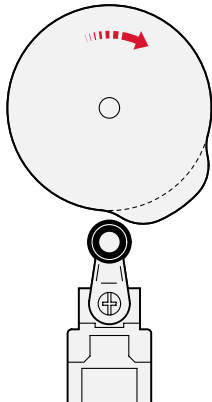

Correct

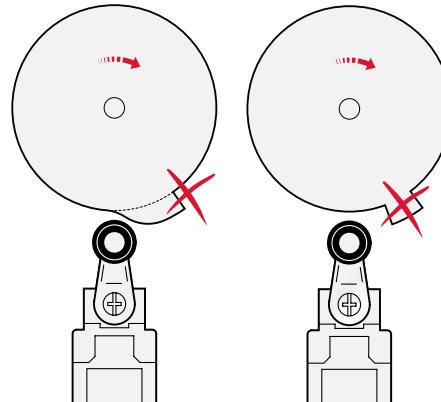

Incorrect

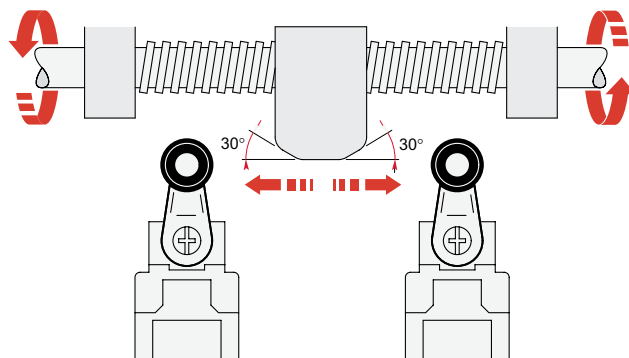

For a relatively slow movement of the switch actuator, a limit switch with a snap action contact block is preferred.

# Technical data EN 50047 standard

The European Committee for Electrotechnical Standardization (CENELEC), which groups together 18 European countries, publishes EN standards.

The present standard defines dimensions and mechanical data for limit switches (30 x 55mm).

## A Shape

Roller lever operating heads

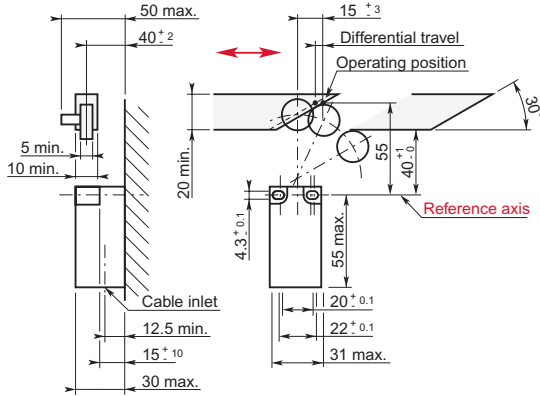

## B Shape

Rounded plunger operating heads

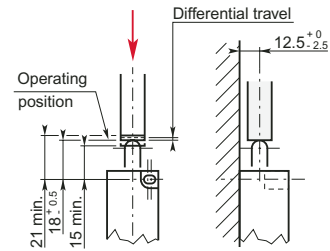

## C Shape

Roller plunger operating heads

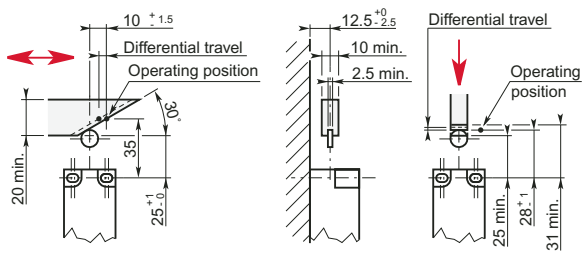

## E Shape

Roller lever operating heads

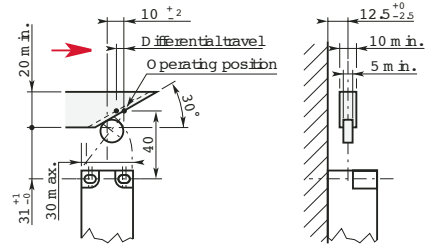

The European Committee for Electrotechnical Standardization (CENELEC), which groups together 18 European countries, publishes EN standards.

## A Shape

Roller lever operating heads

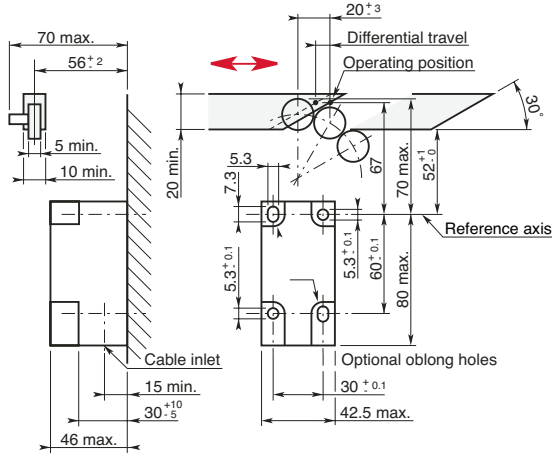

The present standard defines dimensions and mechanical data for limit switches (42.5 x 80 mm).

## B Shape

Rounded plunger operating heads

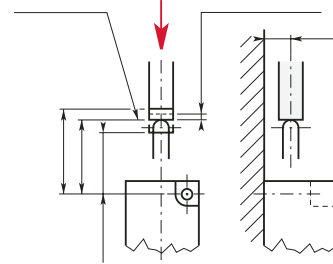

## D Shape

Rod operating heads

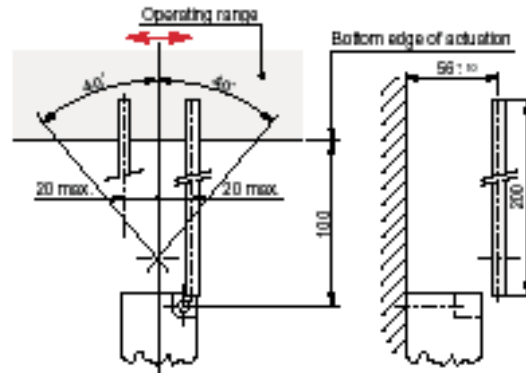

## C Shape

Roller plunger operating heads

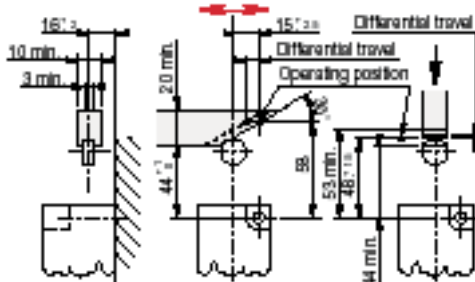

## F Shape

Rounded lateral plunger operating heads

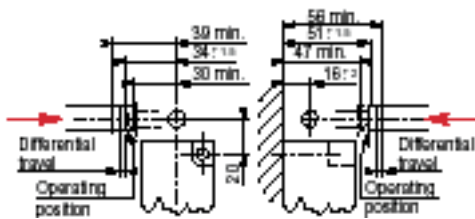

## G Shape

Lateral roller plunger operating heads - Lateral actuation

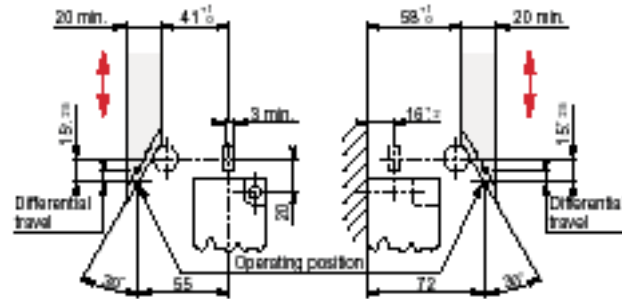

Lateral roller plunger operating heads - Front actuation

