

Warranty, Service & Repair

To register your product with the manufacturer, go to the Flowline website for on-line registration. The website address is as follows:

www.flowline.com

On-line Warranty Registration can be found under Contact Us in the Navigation Bar along the side of the home page.

If for some reason your product must be returned for factory service, contact Flowline Inc. at (562)598-3015 to receive a Material Return Authorization number (MRA), providing the following information:

1. Part Number, Serial Number
2. Name and telephone number of someone who can answer technical questions related to the product and its application.
3. Return Shipping Address
4. Brief Description of the Symptom
5. Brief Description of the Application

Once you have received a Material Return Authorization number, ship the product prepaid in its original packing to:

Flowline Factory Service
MRA _____
10500 Humbolt Street
Los Alamitos, CA 90720

To avoid delays in processing your repair, write the MRA on the shipping label. Please include the information about the malfunction with your product. This information enables our service technicians to process your repair order as quickly as possible.

FLOWLINE®

Smart Trak™ w/ Compact Junction Box A _ _ _ Series Owner's Manual



Version 0.1A

© 2005 FLOWLINE Inc.

All rights reserved.

Manual # LM900005

04/05

WARRANTY

Flowline warrants to the original purchaser of its products that such products will be free from defects in material and workmanship under normal use and service for a period which is equal to the shorter of one year from the date of purchase of such products or two years from the date of manufacture of such products.

This warranty covers only those components of the products which are non-moving and not subject to normal wear. Moreover, products which are modified or altered, and electrical cables which are cut to length during installation are not covered by this warranty.

Flowline's obligation under this warranty is solely and exclusively limited to the repair or replacement, at Flowline's option, of the products (or components thereof) which Flowline's examination proves to its satisfaction to be defective. FLOWLINE SHALL HAVE NO OBLIGATION FOR CONSEQUENTIAL DAMAGES TO PERSONAL OR REAL PROPERTY, OR FOR INJURY TO ANY PERSON.

This warranty does not apply to products which have been subject to electrical or chemical damage due to improper use, accident, negligence, abuse or misuse. Abuse shall be assumed when indicated by electrical damage to relays, reed switches or other components. The warranty does not apply to products which are damaged during shipment back to Flowline's factory or designated service center or are returned without the original casing on the products. Moreover, this warranty becomes immediately null and void if anyone other than service personnel authorized by Flowline attempts to repair the defective products.

Products which are thought to be defective must be shipped prepaid and insured to Flowline's factory or a designated service center (the identity and address of which will be provided upon request) within 30 days of the discovery of the defect. Such defective products must be accompanied by proof of the date of purchase.

Flowline further reserves the right to unilaterally waive this warranty and to dispose of any product returned to Flowline where:

- a. There is evidence of a potentially hazardous material present with product.
- b. The product has remained unclaimed at Flowline for longer than 30 days after dutifully requesting disposition of the product.

THERE ARE NO WARRANTIES WHICH EXTEND BEYOND THE DESCRIPTION ON THE FACE OF THIS WARRANTY. This warranty and the obligations and liabilities of Flowline under it are exclusive and instead of, and the original purchaser hereby waives, all other remedies, warranties, guarantees or liabilities, express or implied. EXCLUDED FROM THIS WARRANTY IS THE IMPLIED WARRANTY OF FITNESS OF THE PRODUCTS FOR A PARTICULAR PURPOSE OR USE AND THE IMPLIED WARRANTY OF MERCHANTABILITY OF THE PRODUCTS.

This warranty may not be extended, altered or varied except by a written instrument signed by a duly-authorized officer of Flowline, Inc.

SPECIFICATIONS

Step One

Specifications:

| | |
|-------------------|---|
| Length: | 8" to 10' (20 cm to 3m) |
| Switch points: | 1 to 4 (field adjustable) |
| Orientation: | $\pm 30^\circ$ vertical |
| Process temp.: | F: -40° to 194° C: -40° to 90° |
| Pressure: | Atmospheric |
| Wetted material: | PP (20% glass fill) |
| Process mount: | 2" NPT (2" G) |
| Enclosure rating: | NEMA 4X (IP65) |
| Installed height: | 5.7" (14.4 cm) above tank process mount |
| Encl. material: | PP, UL94VO |
| Conduit entrance: | Single, 1/2" NPT |
| Termination: | 12 poles |

Ultrasonic sensor

| | |
|-----------------|---|
| Supply voltage: | 12-36 VDC |
| Consumption: | 25 mA maximum |
| Contact type: | (1) SPST relay |
| Contact rating: | GP: 120 VAC/VDC @ 60 VA IS: 32 VDC @ 0.5A |
| Cable type: | 4-conductor / sensor, #22 AWG (shielded) |
| Contact output: | Selectable NO/NC |
| Classification: | Intrinsically safe |
| CE compliance: | EN 50082-2 immunity EN 55011 emission EN 61010-1 safety |

Vibration sensor

| | |
|-----------------|---|
| Supply voltage: | 12-36 VDC |
| Consumption: | 25 mA maximum |
| Contact type: | (1) SPST relay |
| Contact rating: | 120 VAC/VDC @ 60 VA |
| Cable type: | 4-conductor / sensor, #22 AWG (shielded) |
| Contact output: | Selectable NO/NC |
| Classification: | General purpose |
| CE compliance: | EN 50082-2 immunity EN 55011 emission EN 61010-1 safety |

Buoyancy sensor

| | |
|-----------------|---|
| Contact type: | (1) SPDT reed |
| Contact rating: | 120 VAC/VDC @ 15 VA |
| Cable type: | 3-conductor / sensor, #22 AWG (shielded) |
| Contact output: | Selectable NO/NC |
| Classification: | General purpose |
| CE compliance: | EN 50082-2 immunity EN 55011 emission EN 61010-1 safety |

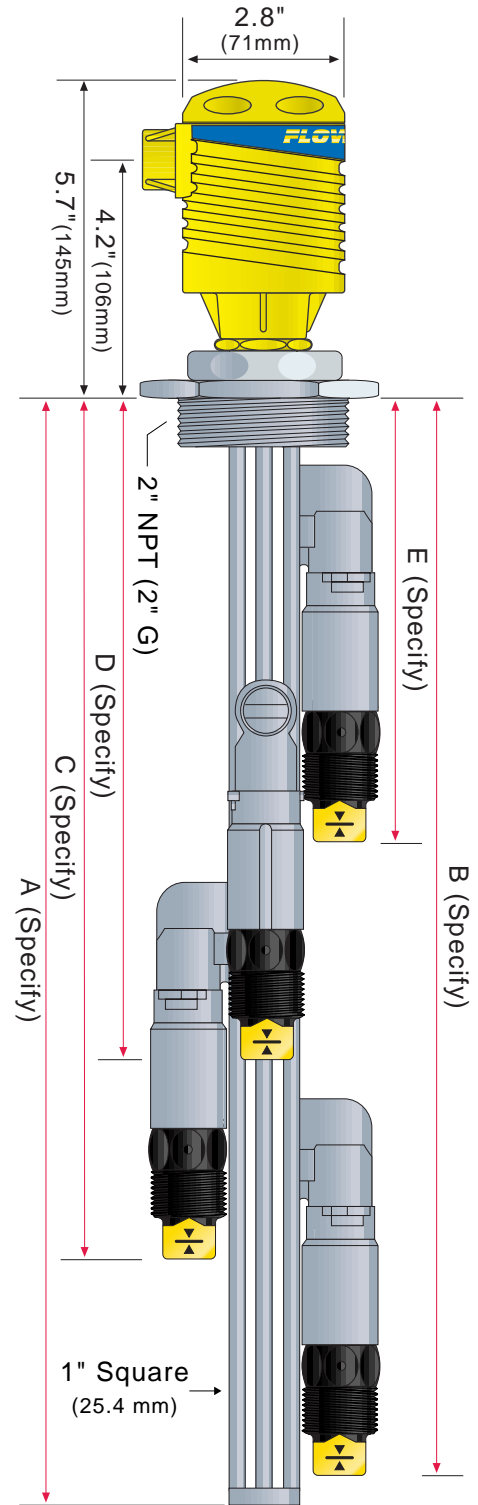

COMPONENTS

Step Two

One Sensor Configuration: (AU15-434_, AV16-434_ or AZ18-434_)

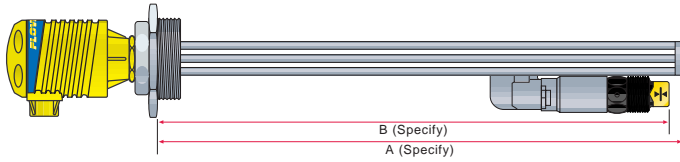

Ultrasonic AU15-4343

1 x LU10-1305
1 x LM10-1_01
1 x LM30-1001
1 x LC05-1001

Buoyancy AV16-4343

1 x LV10-1301
1 x LM10-1_01
1 x LM30-1001
1 x LC05-1001

Vibration AZ18-4343

1 x LZ12-1405
1 x LM10-1_01
1 x LM30-1001
1 x LC05-1001

AU15-4347

1 x LU10-1325
1 x LM10-1_61
1 x LM30-1051
1 x LC05-1051

AV16-4347

1 x LV10-1351
1 x LM10-1_61
1 x LM30-1051
1 x LC05-1051

AZ18-4347

1 x LZ12-1405
1 x LM10-1_61
1 x LM30-1001
1 x LC05-1051

Two Sensors Configuration: (AU25-434_, AV26-434_ or AZ28-434_)

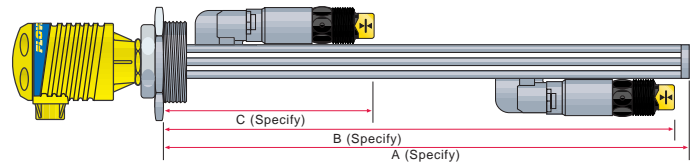

Ultrasonic AU25-4343

2 x LU10-1305
1 x LM10-1_01
2 x LM30-1001
1 x LC05-1001

Buoyancy AV26-4343

2 x LV10-1301
1 x LM10-1_01
2 x LM30-1001
1 x LC05-1001

Vibration AZ28-4343

2 x LZ12-1405
1 x LM10-1_01
2 x LM30-1001
1 x LC05-1001

AU25-4347

2 x LU10-1325
1 x LM10-1_61
2 x LM30-1051
1 x LC05-1051

AV26-4347

2 x LV10-1351
1 x LM10-1_61
2 x LM30-1051
1 x LC05-1051

AZ28-4347

2 x LZ12-1405
1 x LM10-1_61
2 x LM30-1001
1 x LC05-1051

Three Sensors Configuration: (AU35-434_, AV36-434_ or AZ38-434_)

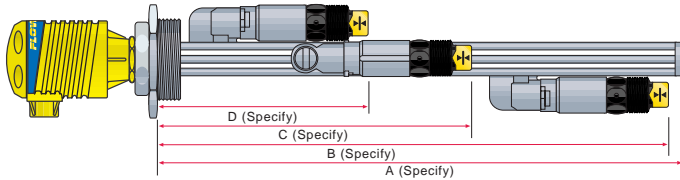

Ultrasonic AU35-4343

3 x LU10-1305
1 x LM10-1_01
3 x LM30-1001
1 x LC05-1001

Buoyancy AV36-4343

3 x LV10-1301
1 x LM10-1_01
3 x LM30-1001
1 x LC05-1001

Vibration AZ38-4343

3 x LZ12-1405
1 x LM10-1_01
3 x LM30-1001
1 x LC05-1001

AU35-4347

3 x LU10-1325
1 x LM10-1_61
3 x LM30-1051
1 x LC05-1051

AV36-4347

3 x LV10-1351
1 x LM10-1_61
3 x LM30-1051
1 x LC05-1051

AZ38-4347

3 x LZ12-1405
1 x LM10-1_61
3 x LM30-1001
1 x LC05-1051

Four Sensors Configuration: (AU45-434_, AV46-434_ or AZ48-434_)

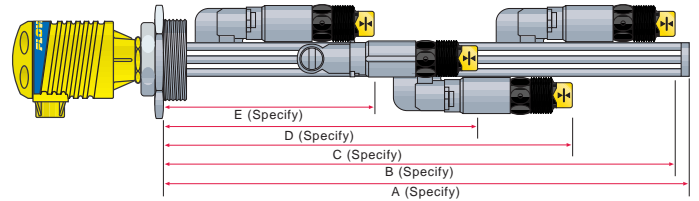

Ultrasonic AU45-4343

4 x LU10-1305
1 x LM10-1_01
4 x LM30-1001
1 x LC05-1001

Buoyancy AV46-4343

4 x LV10-1301
1 x LM10-1_01
4 x LM30-1001
1 x LC05-1001

Vibration AV48-4343

4 x LZ12-1405
1 x LM10-1_01
4 x LM30-1001
1 x LC05-1001

AU45-4347

4 x LU10-1325
1 x LM10-1_61
4 x LM30-1051
1 x LC05-1051

AV46-4347

4 x LV10-1351
1 x LM10-1_61
4 x LM30-1051
1 x LC05-1051

AZ48-4347

4 x LZ12-1405
1 x LM10-1_61
4 x LM30-1001
1 x LC05-1051

Component List:

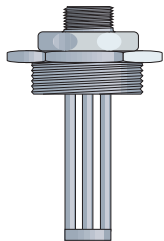

Smart Trak Fitting

P/N: LM10-1_01 or LM10-1_61

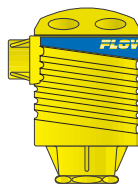

Compact Junction Box

P/N: LC05-1001 or LC05-1051

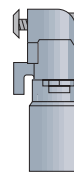

Switch Car Kit

P/N: LM30-1001 or LM30-1051



Switch-Tek Level Switch

P/N: LU10-1305, LU10-1325,
LV10-1301, LV10-1351
or LZ12-1405

SAFETY PRECAUTIONS

Step Three

⚠ About this Manual: PLEASE READ THE ENTIRE MANUAL PRIOR TO INSTALLING OR USING THIS PRODUCT. This manual includes information on the Smart Trak™ with Compact Junction Box: AU_5-434_, AZ_8-434_ and AV_6-343_. The units are identical except for the number of switch points and the sensors technology.

⚠ User's Responsibility for Safety: Flowline manufactures a wide range of liquid level sensors, controllers, and mounting systems. It is the user's responsibility to select components that are appropriate for the application, install them properly, perform tests of the installed system, and maintain all components. The failure to do so could result in property damage or serious injury.

⚠ Proper Installation and Handling: Use a proper sealant with all installations. Never overtighten the components. Always check for leaks prior to system start-up.

⚠ Material Compatibility:

Glass filled Polypropylene (PP, a polyolefin): Track, end cap, wire retainer clips, bayonet adapter, level switch and sensor car for all Smart Trak Assemblies.

Polychlorotrifluoroethylene (PTFE, a fluoroplastic): Sensor car locking bolt and screw.

Polypropylene (PP, a polyolefin): Sensor, top compression fitting, thrust plate, locking pin and 2" NPT fitting.

Viton (a fluorocarbon): O-ring.

Neoprene (w/silicon gel for lubrication): Wire gasket.

Santoprene (w/silicon gel for lubrication): Seal plug.

Make sure that the application liquids are compatible with the materials that will be wetted. To determine the chemical compatibility between the components and its application liquids, refer to the Compass Corrosion Guide, available from Compass Publications (phone 858-589-9636).

⚠ Temperature and Pressure: Smart Trak™ is designed for use in application temperatures up to 90° C (194° F). It is not designed for pressurized applications due to the wiring that must travel through a gasket at the head.

⚠ Wiring and Electrical: Electrical wiring of any liquid level control system should be performed in accordance with all applicable national, state, and local codes. Take care not to cut or break the outer insulation jacket of wiring that may be immersed while routing cables in the Smart Trak™ system. Such breaks of the liquid seal of the sensor system may lead to component failure.

⚠ Flammable, Explosive and Hazardous Applications: Smart Trak™ may be used within flammable or explosive applications only if the associated components are rated intrinsically safe for such use. In hazardous applications, use redundant measurement and control points, each having a different sensing technology.

⚠ Make a Fail-Safe System: Design a fail-safe system that accommodates the possibility of transmitter or power failure. In critical applications, Flowline recommends the use of redundant backup systems and alarms in addition to the primary system.

ASSEMBLY OF SMART TRAK™

Step Four

About Smart Trak™: Flowline's Smart Trak™ with Compact Junction Box Assembly is an adjustable mounting system for installing multiple level sensors vertically within a tank. Mounted through a single point at the top of the tank, up to 4 different sensors can be located at any depth on Smart Trak™. The compact junction box features termination for the various wires from each level switch as well as a 1/2" conduit connection. Smart Trak™ mounts vertically through a standard 2" NPT tank adapter, or on a side mount bracket (such as the LM50-1001). Unlike prefabricated "trees" or pipes, Smart Trak™ allows you to experiment with sensor position to account for variations in the point of actuation of each sensor during process testing.

Track: The track itself is approximately 1" square, and is from 8" to 10' long depending on the A-Dimension. The track may be cut to length if desired. Four separate grooves run the length of the track, one on each side of the square. These grooves hold the sensor cars that attach to Flowline sensors, and also serve to contain the switch cable. The bottom of the track is capped with an end cap.

Level Switches: Smart Trak™ will include from 1 to 4 level switches used to identify it's own unique wet / dry condition. The technologies used to indicate level are either Ultrasonic, Buoyancy or Vibration. Each technology features a unique wiring/power configuration (Ultrasonic and Vibration technologies require 12 to 36 VDC power for operation, see below). All of the switches are terminated in the Compact Junction Box. The Compact Junction Box provides a 1/2" Conduit connection and 12 poles for wire termination (for models AU45-434_ and AZ48-434_, common terminals such as Positive (+) and Negative (-) power must be shared).

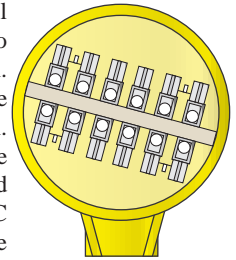

Compact Junction Box (inside shown)

Vibration (LZ12-1405) Wire Configuration:

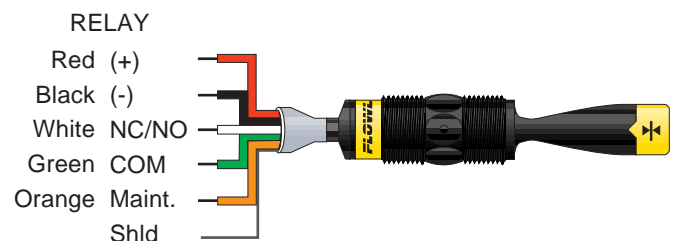

Ultrasonic (LU10-1305 or LU10-1325) Wire Configuration:

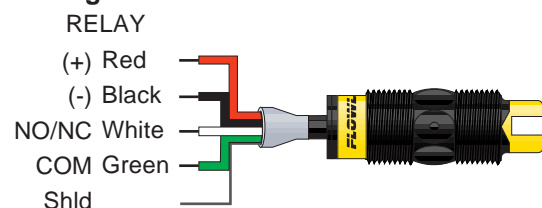

Buoyancy (LV10-1301 or LV10-1351) Wire Configuration:

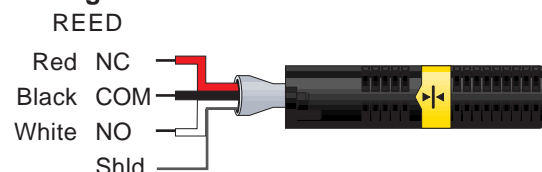

INSTALLATION

Step Five

Smart Trak™, In-Tank Installation:

Flowline's Smart Trak™ mounting system is an in-tank fitting, which enables users to install any technology, along the entire length of track. Smart Trak™ may be installed thru the top wall of any tank or flange, using a standard 2" NPT tank adapter or blind flange. If tank top is not available, Flowline's side mount bracket, LM50-1001, enables Smart Trak™ to be installed directly to the side wall or lip of the tank.

Tank Adapter:

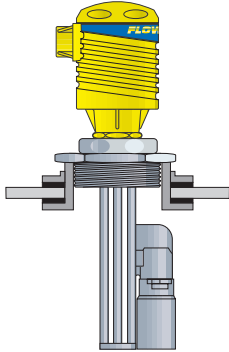

Flange Mounting:

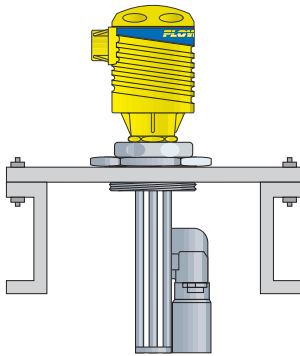

Side Mount Bracket:

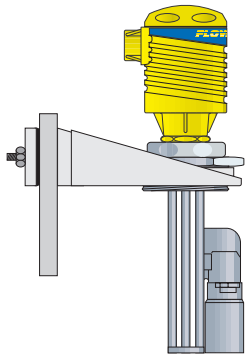

Lip of Tank

Side-Wall

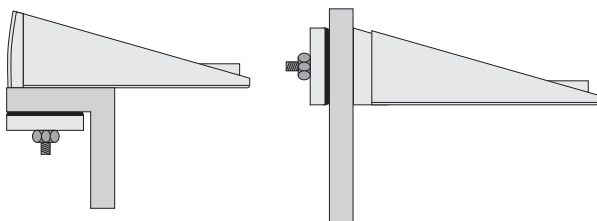

INSTALLATION

Step Six

Smart Trak™, Installation:

The Smart Trak™ with Compact Junction Box assembly is designed to be installed through a 2" NPT (2" G) thread. The level switches will be staggered through the fitting for installation.

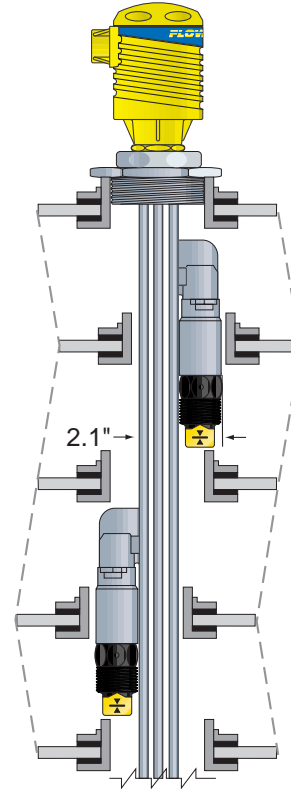

A key feature of Smart Trak™ is the adjustability of the level switches. When two level switches are placed close together, one of the switches will need to be moved to allow for the switches to be staggered into the installation fitting. Once installed, the level switch can be returned to its required position.

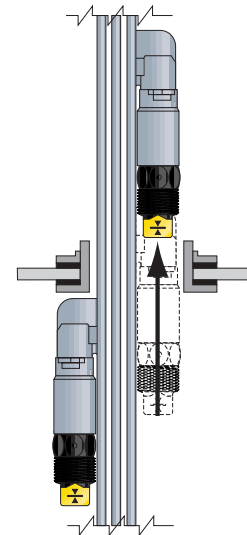

WIRING

Step Seven

Ultrasonic and Vibration Switches (LU10-1305, LU10-1325, LZ12-1405):

The LU10-13_5 and LZ12-1405 switch can be wired normally open or normally closed for your application requirement. Each switch requires 12 - 36 VDC power to operate the sensor and switch the relay. The relay output can be wired as a dry contact. All illustrations below identify a Dry switch state as the normal position of the relay.

Switching a Normally Open DC Load:

The Red wire connects to Positive (+) of the power supply and the Black wire connects to Negative (-). The LOAD can be attached to either the Green or White wires. Complete the circuit by either connecting the Green to (+) VDC power or White to (-) VDC power (see illustration below).

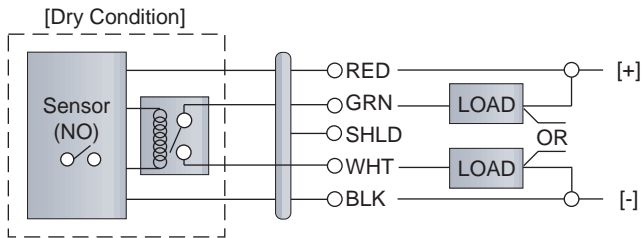

Switching a Normally Closed DC Load:

The Black wire connects to Positive (+) of the power supply and the Red wire connects to Negative (-). The LOAD can be attached to either the Green or White wires. Complete the circuit by either connecting the Green to (+) VDC power or White to (-) VDC power (see illustration below).

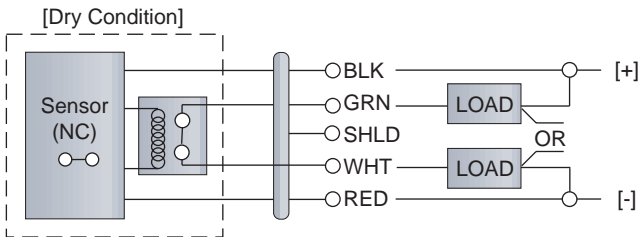

Maintenance Alarm (LZ12 Vibration only):

For optimum performance and proactive maintenance, the sensor automatically adjusts for coating, and if necessary, outputs a preventative maintenance alarm. The Orange wire is a NPN transistor designed to switch when a build-up of material prevents the vibration switch from operating at its operational frequency. Use the Orange wire to identify when the Vibration switch requires cleaning (see the LZ12 manual for wiring information).

WIRING

Step Eight

Buoyancy Level Switch (LV10-1301 & LV10-1351):

The LV10-13_1 switch can be wired normally open or normally closed for your application requirement.

Normally Open:

Use the Black and White wires for operating the LV10-_3_1 in a normally open state. Normally open is defined as the switch being open when the float is dry and closed when the float becomes submersed. This operation is typical for indicating a high level.

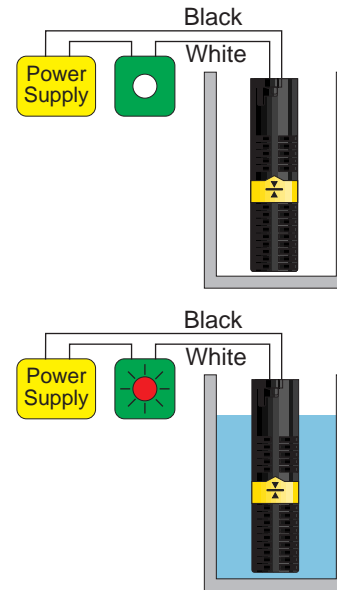

Normally Closed:

Use the Black and Red wires for operating the LV10-_3_1 in a normally closed state. Normally closed is defined as the switch being closed when the float is dry and open when the float becomes submersed. This operation is typical for indicating a low level.

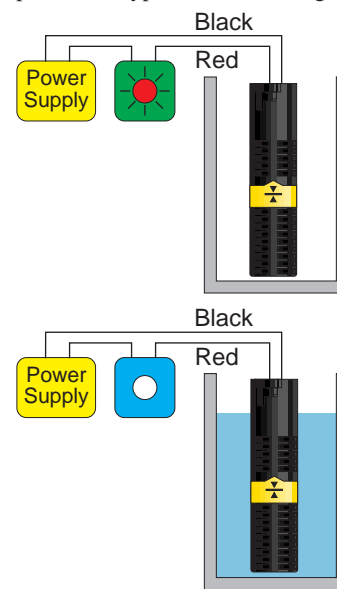

ASSEMBLY OF SMART TRAK™

Step Nine

Smart Trak™ Assembly Drawing (Side View)

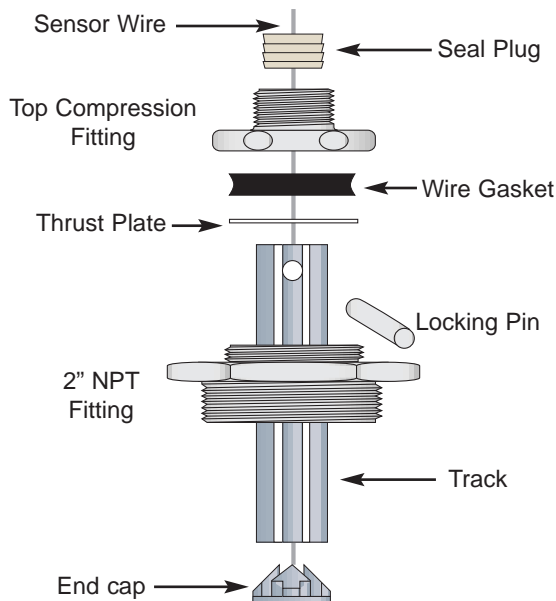

Inventory:

One Smart Trak™ kit (LM10-1__1) includes the following parts:

- | | |
|-----------------------------------|---------------------------|
| 1 Seal Plug | 1 Top compression fitting |
| 1 Wire gasket | 1 Thrust Plate |
| 1 Locking pin | 1 2" NPT fitting |
| 1 Track | 1 End cap |
| 2 Wire retainer clips (not shown) | |

Smart Trak™ Assembly Drawing (Top View):

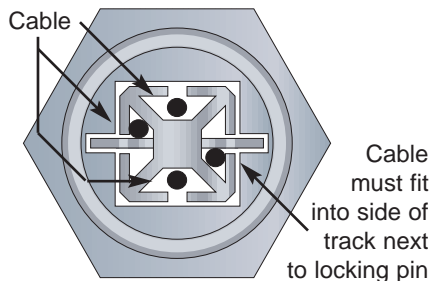

Seal Plug Assembly Drawing (Side View)

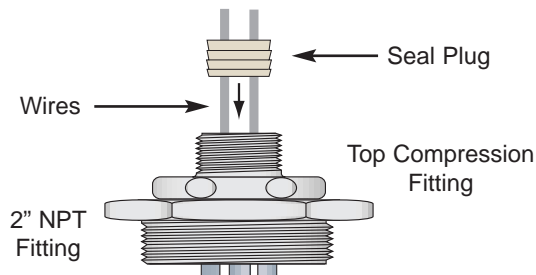

ASSEMBLY OF SWITCH CAR

Step Ten

Sensor car and bayonet adapter:

The sensor car assembly is the heart of the Smart Trak™ system. It slides in the grooves of the track, and is locked into position by a plastic bolt and screw. The bayonet to 3/4" NPT adapter has a female 3/4" NPT fitting on one end where the sensor (not included) will screw in, and a bayonet fitting on the other end that attaches it onto the sensor car with a slight turn, with an O-ring in-between to provide tension for the push-and-turn connection.

Switch Car Kit Assembly Drawing (Side View)

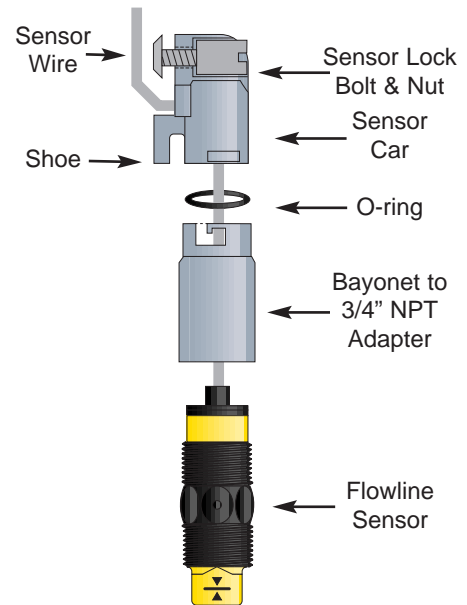

Inventory:

One switch car kit (LM30-10_1) consists of the following parts:

- | | |
|-------------------------------|---------------|
| 1 Locking bolt | 1 Locking Nut |
| 1 Sensor car | 1 O-ring |
| 1 Bayonet to 3/4" NPT adapter | |

Switch Car Kit to Smart Trak™

(Top View)

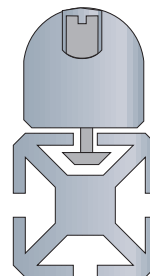

(Side View)

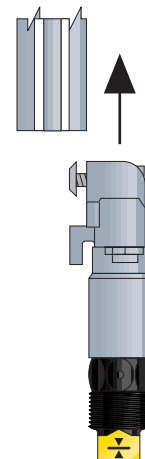

Determine the Proper Wire Length:

Don't make the mistake of trimming the sensor wires too short before the process is tested. If the sensors might need to be lowered in the future, leave sufficient slack in the wires to allow for future adjustment. This extra wire may be stored in the bottom of the terminal strip housing, or elsewhere above the compression fitting.

MAINTENANCE

Step Eleven

General:

The Smart Trak™ with Compact Junction Box requires no periodic maintenance except cleaning as required. It is the responsibility of the user to determine the appropriate maintenance schedule, based on the specific characteristics of the application liquids.

Cleaning Procedure:

- 1. Power:** Make Sure that all power to the sensor, controller and/or power supply is completely disconnected.
- 2. Sensor Removal:** Make sure that the tank is in a state where it is safe to remove the sensors. Carefully, remove the Smart Trak™ from the installation.
- 3. Cleaning the Sensor:** Use a soft bristle brush and mild detergent, carefully wash the Smart Trak™. Do not use harsh abrasives such as steel wool or sandpaper, which might damage the surface sensor. Do not use incompatible solvents which may damage the sensor's PP or Ryton plastic body.
- 4. Sensor Installation:** Follow the appropriate steps of installation as outlined in the installation section of this manual.

Testing the installation:

- 1. Power:** Turn on power to the switches and/or power supply.
- 2. Immersing the switch:** Immerse the sensing tip of each switch in its application liquid, by filling the tank up to the switches point of actuation. An alternate method of immersing the switch during preliminary testing is to hold a cup filled with application liquid up to the switch's tip.
- 3. Test:** With the switch being fluctuated between wet and dry states, the switch will open or close depending on wiring status. If the system doesn't have an input indicator, use a voltmeter or ammeter to ensure that the switch produces the correct signal.
- 4. Point of actuation:** Observe the point at which the rising or falling fluid level causes the switch to change state, and adjust the installation of the switch if necessary.

MAINTENANCE

Step Twelve

Current Test (Ultrasonic and Vibration only):

Used to verify if the sensor is indicating a wet or dry condition. This test uses only two wires (Red and Black). The sensor draws 5 mA (ultrasonic) or 8 mA (vibration) when it is dry, and 19 mA when wet. The White and Green wires are not used.

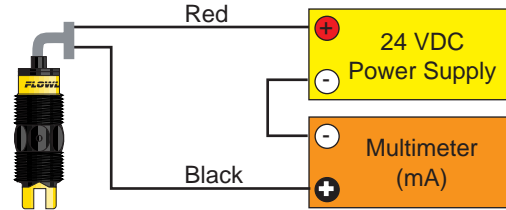

Relay Contact Test (Ultrasonic and Vibration only):

Used to verify if the relay contact is switching between dry (open) and wet (closed). Test requires Red wired to Positive (+) and Black wired to Negative (-) on a 12 to 36 VDC power supply. Check for continuity across Green and White (open for dry and closed for wet). Reversing Red and Black wires will result in a closed when dry and open when wet condition.

Normally Open Wiring:

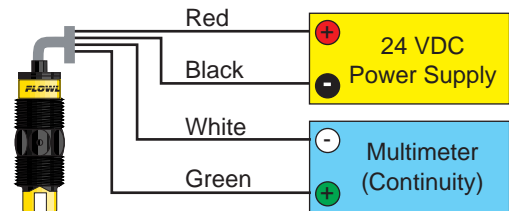

Contact Test (Buoyancy only):

Used to verify if the reed switch is switching between dry (open) and wet (closed). Check for continuity across Black and White (open for dry and closed for wet). Checking across Black and Red will result in a closed when dry and open when wet condition.

