

Cable Management

Since 1911, Gleason Reel Corp. has been in the business of CABLE MANAGEMENT. Our products are designed to convey and protect valuable cables and hoses that power and control moving machines of all types. They improve productivity and safety on the job by moving cables and hoses away from hazardous locations on machinery or the shop floor into a controlled environment. Whether you choose Reels for efficient storage and payout from virtually any angle, Festoon Systems for overhead applications or PowerTrak® for protection on machinery in motion, your cables and/or hoses will last longer and provide better service with a cable management system from **Gleason Reel Corp...**

...The Cable & Hose Management Company!



Bulletin "CR"
Heavy Duty
Spring Driven
Electric Cable Reels
General Industrial



Bulletin "MR"
Extra Heavy Duty
Spring Driven
Electric Cable Reels
Demanding Service



Bulletin "VMR"
Large Retrieving
Motor Driven
Electric Cable Reels
Heavy Duty Industrial



Bulletin "RET"
Long Travel Length
Motor Driven
Electric Cable Reels
Standard Industrial



Bulletin "PSR"
Lifting & Lowering
Motor Driven
Electric Cable Reels
Push-Button Reels



**Cable and Hose Reels
for Emergency Vehicles**
Specialty Reels

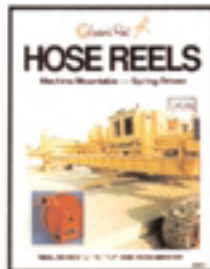

Bulletin "HRM"
Various Types
Spring Driven
Hose Reels
General Industrial



Bulletin "SR"
Slip Rings
Unitized Design
Low & High Amperage
Low & Medium Voltage



Bulletin "PTG"
Non-Metallic
Cable Chain
For Hose & Cable
Lightweight, Economical



Bulletin "PT"
Rugged Steel
Cable Chain
For Hose & Cable
Standard & Mill Duty

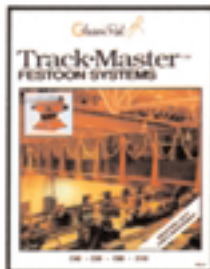

Bulletin "FC"
Rugged Steel
C-Rail Mounted
Festoon Systems
General Industrial



Bulletin "FB"
Heavy Duty
I-Rail Mounted
Festoon Systems
Heavy Duty Port Types



REELS

SERIES **S**
SPRING

SERIES **WB**
SPRING

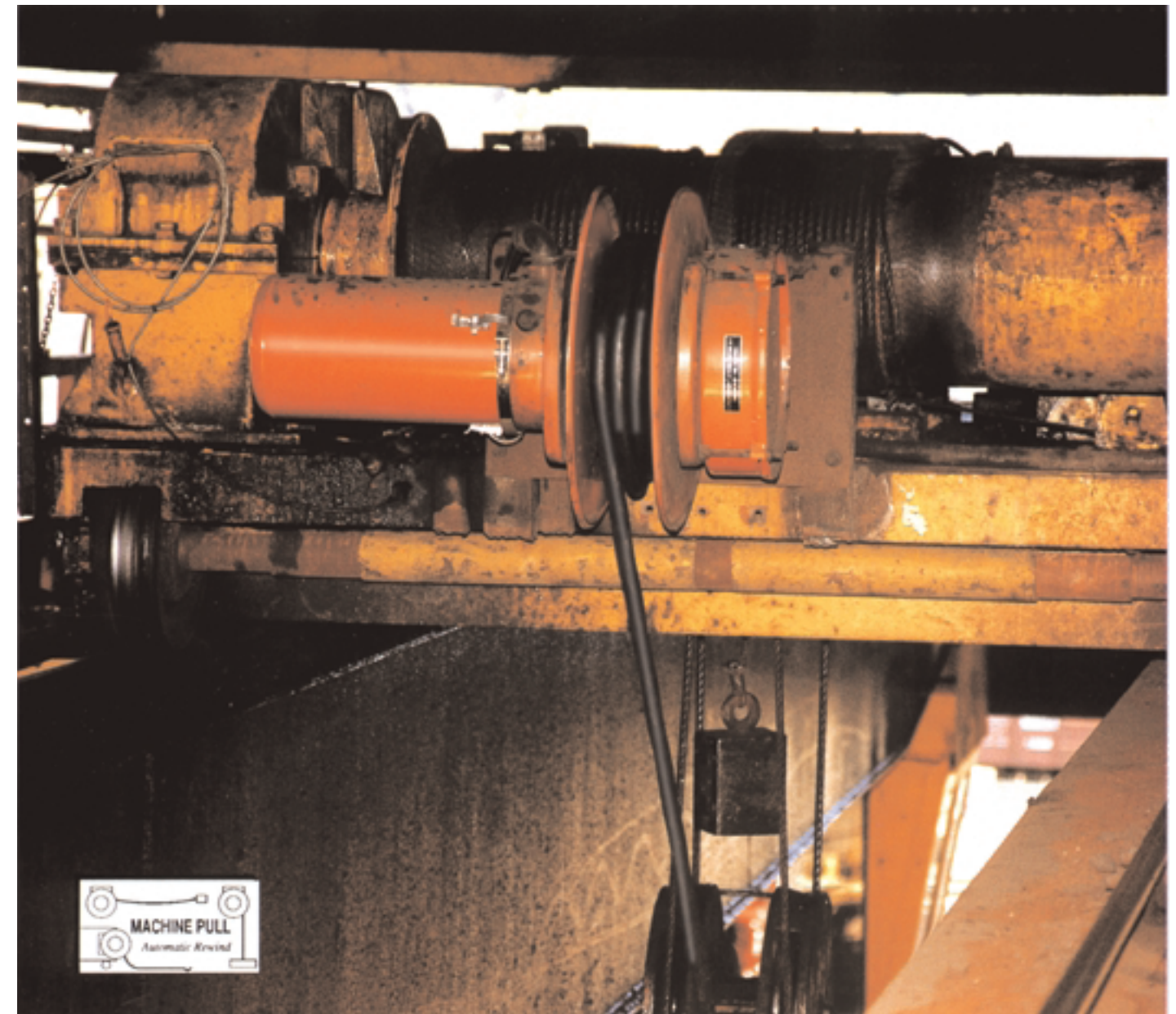

HEAVY DUTY Lift, Stretch and Retrieve Reels

Spec Tech Industrial 203 Vest Ave. Valley Park, MO 63088 Phone: 888 SPECTECH
Email: sales@spectechind.com www.spectechind.com

Spec Tech Industrial 203 Vest Ave. Valley Park, MO 63088 Phone: 888 SPECTECH
Email: sales@spectechind.com www.spectechind.com

Contents

General Information

Types in This Catalog3
Ordering3
Description of Reels4-7
Slip Rings4-5
Spring Motors6
Cable Length30-31
Gleason Product Line32

Selection

How to Select8-9
Selection Chart10-15

Technical Data—Series S Cable Reels

Optional Accessories16
Model S14 Direct Drive17
Model S16 Direct Drive18
Model S18 Direct Drive19
Model S21 Direct Drive20
Model S21 Gear Drive21
Model S24 Direct Drive22
Model S24 Gear Drive23
Model S28 Direct Drive24
Model S28 Gear Drive25
Model S32 Direct Drive26
Model S32 Gear Drive27

WB Continuous Contact Electric Reels

Selection Charts28
Technical Data29

Cable Data

Length Calculations30
Typical Cable Specifications31

WARRANTY

Gleason warrants for a period of twelve (12) months after date of shipment, all goods manufactured by it to be free from defects in material and workmanship. If, within such warranty period, any such goods are proved, to Gleason's satisfaction, to be defective, such goods shall be repaired or, at Gleason's options, replaced f.o.b. Gleason's factory, without charge. Gleason's obligation hereunder shall be confined to such repair or replacement and shall be further conditioned upon Gleason's receiving written notice of any alleged defect within 10 days after its discovery and, at Gleason's option, the return of the allegedly defective goods to Gleason, f.o.b. its factory.

The foregoing warranty shall not apply to goods not manufactured by Gleason, or to goods which shall have been repaired or altered by others than Gleason so as, in Gleason's judgement, adversely affect the same, or which shall have been subject to other than normal care, or storage. With respect to goods furnished but not manufactured by Gleason, the warranty obligations of Gleason shall in all respects conform and be limited to the warranty extended to Gleason by the supplier.

The foregoing warranty is in lieu of all other express or implied warranties (except of title) and of all other obligations of Gleason.



ON THE COVER: Typical Gleason Series "S" reel mounted on an overhead crane for heavy duty, high cycle, vertical lift service.

Spring-Driven **ELECTRIC CABLE REELS**



In This Catalog...

Series “S” Spring-Driven Electric Cable Reels

Gleason Series “S” reels are spring driven electric cable reels designed to be mounted on moving machinery. Electric current flows from your power source to the current consumer through the cable you specify. S-Reels utilize self-contained slip ring assemblies which transfer current to the cable mounted on the rotating spool. Models for longer travels are fitted with gear assemblies to provide hundreds of application possibilities. Specific application details can be found in this catalog or prepared by our staff for your most exacting requirements.

OPTIONAL SLIP RING ENCLOSURES for hazardous area (Class I and Class II), are available on request.

OPTIONAL ACCESSORIES include roller guide, hoop guides (shown installed on reel at right), rotary limit switch, spool lock, ratchet lock assembly (for hand-pull applications only) and swivel base.

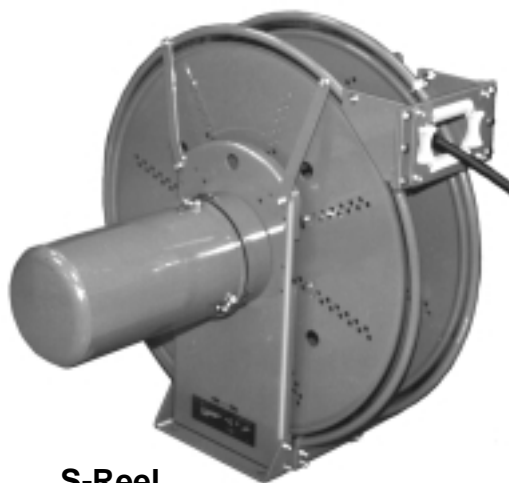

S-Reel

Series “WB” Cable Reels without Slip Rings

For applications such as communication where any variation in impedance must be avoided, choose Gleason Series “WB” continuous contact reels which have no slip rings. Because WB-Reels use one continuous length of cable, there is no break from current source to consumer and that means complete preservation of transmission integrity. This transmission integrity makes WB Reels ideal for use with fiber optic cable.

WB reels are actually two reeling systems in one, winding active and inactive cable separately. The inactive cable compensates for the rotation of the active drum as active cable is payed out and rewind.

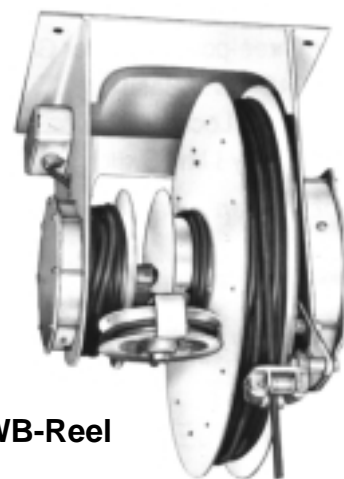

WB-Reel

ORDERING

To order Gleason Electric Cable Reels, simply contact the Gleason Reel representative in your area.

GLEASON REEL CORP.

Phone: 920-387-4120

Fax: 920-387-4189



Spring-Driven

ELECTRIC CABLE REELS

MACHINE MOUNTABLE

Reels in this catalog are intended for mounting on machinery where automatic (unattended) movement is required. Other Gleason cable reels are available for hand pull applications. Please consult us for recommendations.

FULL RANGE OF ACCESSORIES AVAILABLE...

- ✓ Three-position Roller Guides
- ✓ 3400 Pivot Base
- ✓ Spool Lock
- ✓ Rotary Limit Switch

See "Dimensional Data" for Details

AVAILABLE FOR ALL STANDARD AND MOST SPECIAL REQUIRE- MENTS

This catalog provides details on sizes, capacities, specifications and designs. If you need additional information, contact your local factory representative. Full support is available upon request.

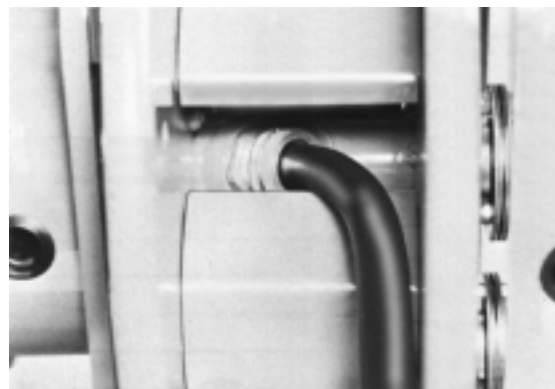

SIMPLE, POSITIVE CABLE ENTRANCE...A positive, watertight connector is provided at the shaft where the cable enters the spool area. Cable feeds easily through the hollow shaft for termination within the slip ring enclosure. Connections are required at one point only.



EASILY REMOVABLE SLIP RING ENCLOSURE... Removes quickly for inspection or service by virtue of the three toggle clamps. An "O" ring seal provides a watertight, dust-tight seal suitable for any type of atmosphere.

OPTIONAL ENCLOSURES, designed for hazardous areas (Class I and Class II), are available upon request.

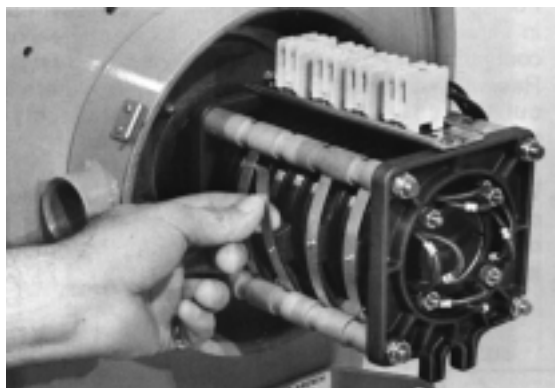

FAST, EASY BRUSH REPLACEMENT... Gleason's brush holder assembly features a unique spring design which permits quick brush removal while ensuring full contact throughout the life of the brush.

SIMPLE, POSITIVE SPOOL LOCK...

Available as an accessory to facilitate cable changing. Permits cable change while reel in under full tension. When released, reel will rewind entire length of new cable.

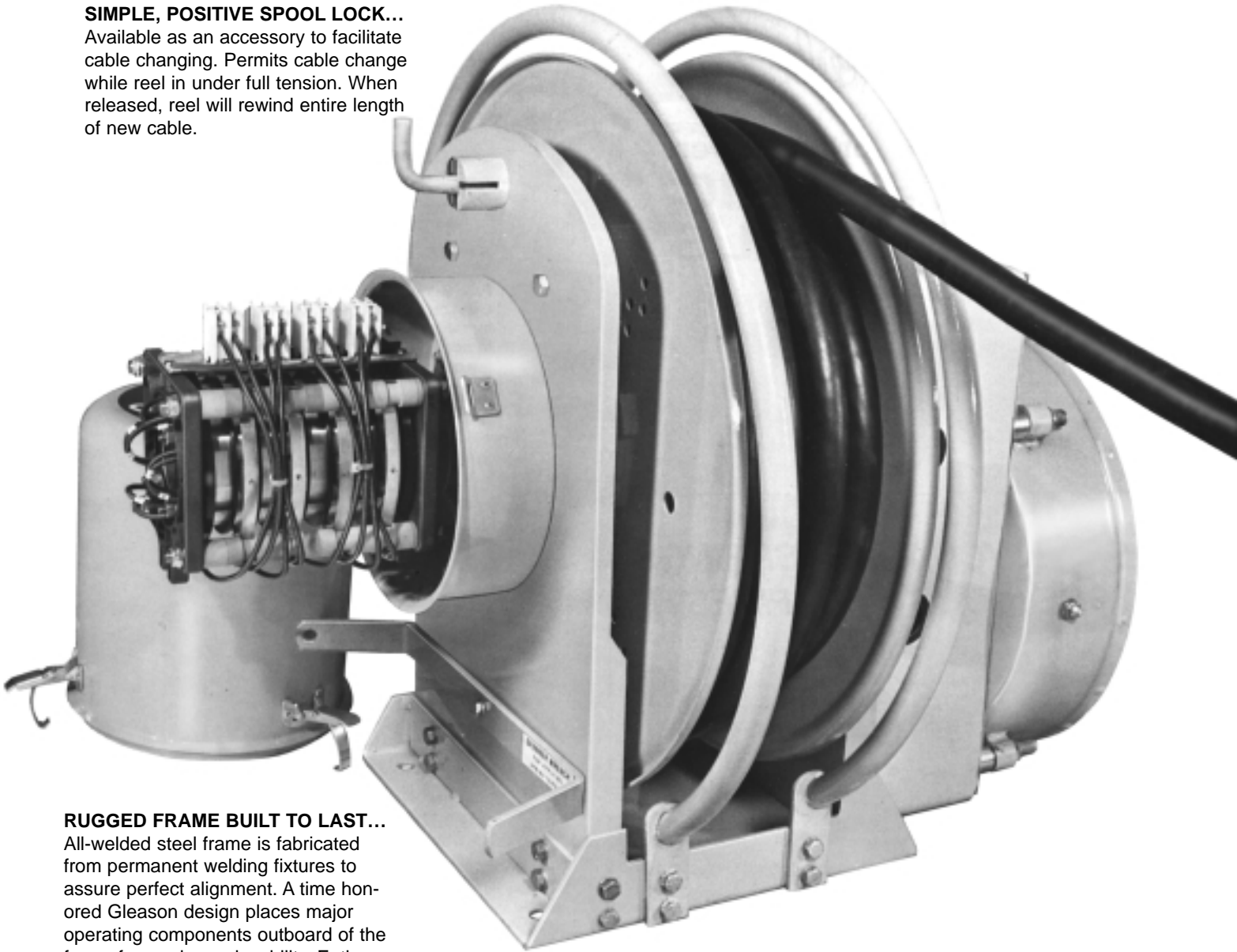

RUGGED FRAME BUILT TO LAST...

All-welded steel frame is fabricated from permanent welding fixtures to assure perfect alignment. A time honored Gleason design places major operating components outboard of the frame for ready serviceability. Entire unit is painted with baked polyester for a long-lasting, durable finish.

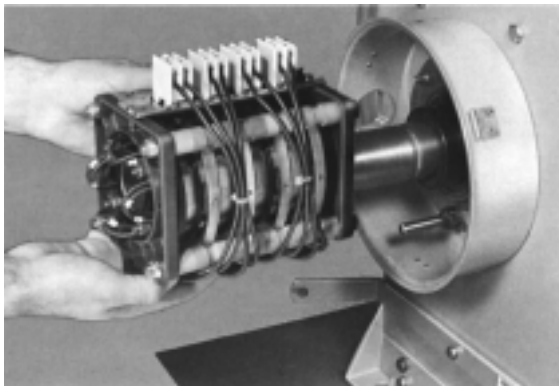

QUICK, ONE PIECE REMOVAL... The entire slip ring assembly can be replaced as a unit, if necessary. No need to handle small parts. To remove, simply disconnect wiring and loosen two set screws on the shaft-locking collar.



EVEN WINDING IN MULTIPLE LAYERS... Edges of steel flanges on cable spool are die-formed to eliminate cable pileup in corners. Segmenting of inner drum permits adjustability to suit various cable diameters – a slight change in cable size may be accommodated by the same reel with only minor field adjustment.



Spring-Driven
**ELECTRIC
CABLE REELS**

**SAFETYCHANGE® SPRINGS
ARE INDUSTRY'S FINEST!**



Gleason uses high-quality spring steel to manufacture these "self-contained" main springs. All springs are lifetime lubricated prior to sealing in disposable Safetychange® housings. When used on multi-spring reels, all springs are connected in parallel so that, in the event that one spring fails, the reel is never without tension. This is a significant safety feature.

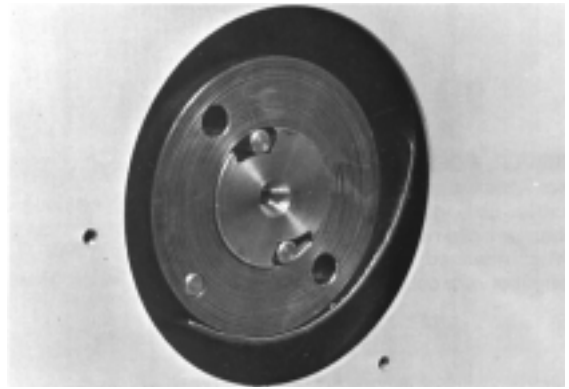

FREE-WHEELING HUB FOR SPRING MOTOR...
Gleason's unique free-wheeling spring hub design allows for easy cable installation and spring tension adjustment. In addition, it protects the spring motor in the event that the cable is severed.

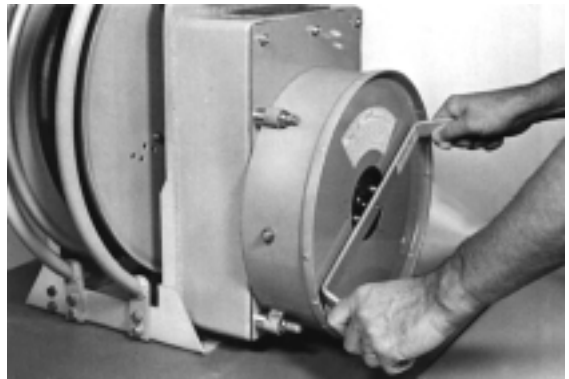

SAFE, SIMPLE SPRING TENSION ADJUSTMENT...
To adjust spring tension, simply remove the inspection cover and adjust with spanner wrench provided. No need to disconnect cable or disassemble reel. The correct number of spring pretension turns is indicated on each reel nameplate.

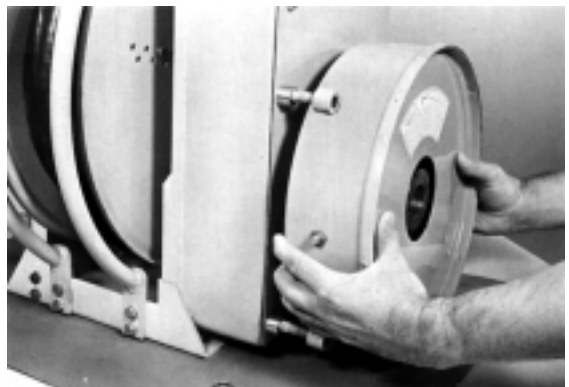

DESIGNED WITH SAFETY IN MIND...
The Safetychange® spring motor is a power spring sealed in a disposable housing, eliminating the need to handle loose springs. Located outboard on the frame, replacement is safe and easy and does NOT require the reel to be removed from its frame. All Safetychange® spring motors are equipped with an inspection hole to visually check the integrity of the spring while reel is in service.

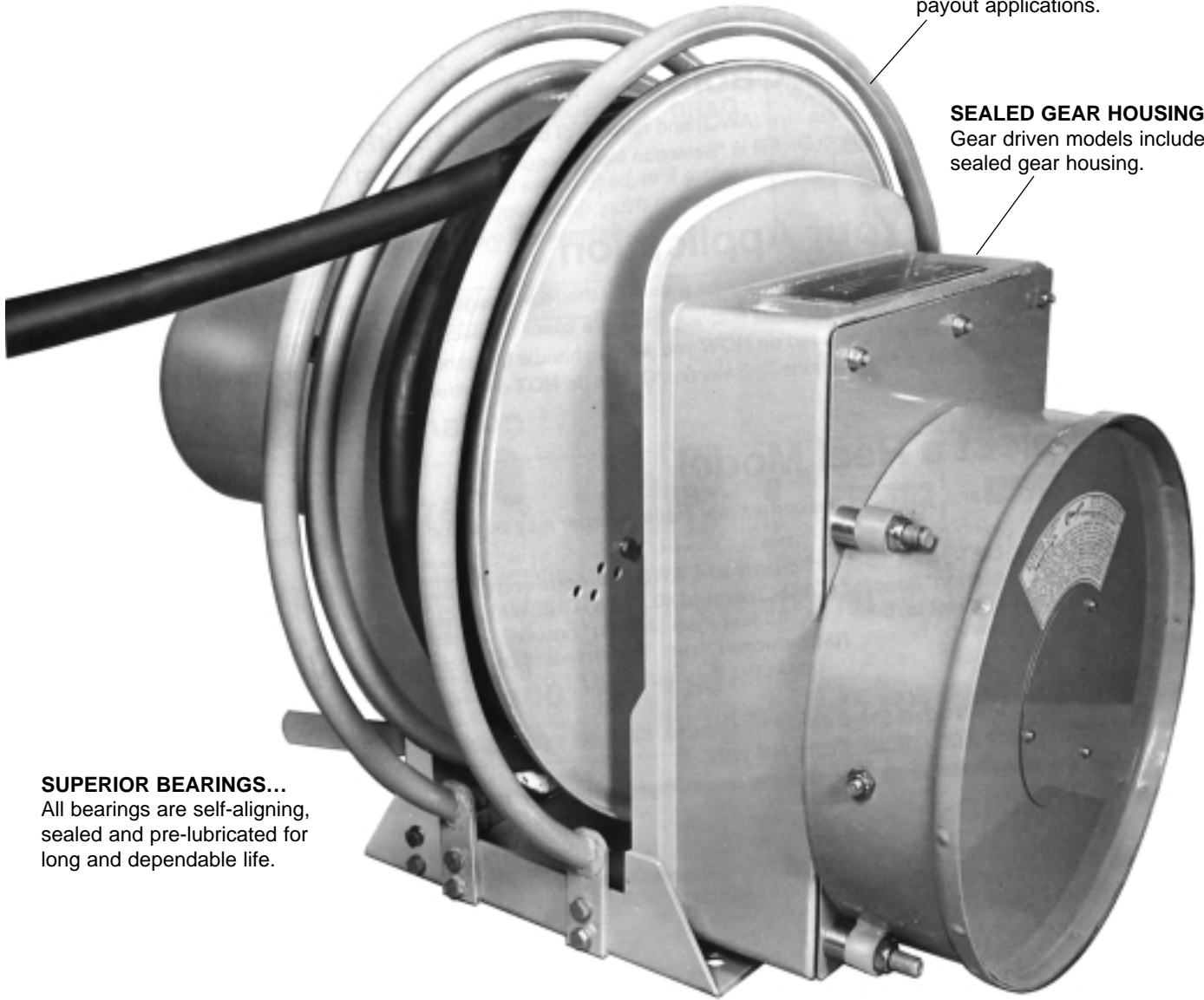

HOOP GUIDES... Optional feature recommended for two-way payout applications.

SEALED GEAR HOUSING... Gear driven models include sealed gear housing.

SUPERIOR BEARINGS... All bearings are self-aligning, sealed and pre-lubricated for long and dependable life.



PROTECTED GEARING... Gears used for reeling longer lengths of cable are protected from dust and moisture by a sealed housing. External grease fitting permits lubrication of gears during service without opening the enclosure. Various gear ratios are available to match specific reeling requirements.



NO SWEAT, NO STRAIN GEAR REMOVAL... Gleason's unique design permits gears to be changed without disassembly of major frame components. Simply remove the spring motor and its removable back plate to fully expose gears for fast, easy changeover.

How to Select Reels

Gleason Electric Cable Reels are assembled from several components with a great variety of combinations possible. In order to select the CORRECT reel from the selection charts on the following pages, follow STEPS 1–3 on this page.

STEP 1 Identify Your Cable

Cable is the **WHAT** in reel selection. **WHAT** is the size (AWG) and number of conductors? Reel calculations are based on the cable weight per foot, Active Travel and cable O.D. Fill in “[Selection Input Required](#)” on the facing page for each reel you order.

STEP 2 Identify Your Application

Application is the **HOW** in reel selection. From the [applications on the facing page](#), choose the one that resembles the way you are applying the cable in STEP 1 above. There are specific selection charts on the following pages for each application type. Reel calculations are based on **HOW** you want to handle the cable. Note: Identify any added weight such as extra cable (overhang) or pushbutton stations – Selection charts do NOT consider any added weight.

STEP 3 Select a Reel Model

Applying your input from STEP 1 and STEP 2, the correct reel model number may be found in one of the Selection Charts on the following pages.

EXAMPLE: A reel must LIFT [TURN TO LIFT CHART] #14 AWG, 10 conductor cable [FIND “14-AWG, 10 CONDUCTOR” ROW] for a Total Travel 40.0 feet, ONE WAY PAYOUT – see Fig. 1 below. Active Travel is, therefore, 40 feet [FIND “40 FEET” COLUMN, THEN FOLLOW “40 FEET” COLUMN DOWN TO “14-AWG, 10 CONDUCTOR” ROW. THE INTERSECTION IS THE CORRECT REEL MODEL – **S16801 - 103 - 9 - 1**].

For requirements not fully covered in the [Selection Charts](#) such as cable sizes, greater Active Travel or greater weight, contact your factory representative. We will be happy to make specific calculations for you.

Definition of terms

- **Active Travel** = The **DISTANCE** in **ONE DIRECTION** from reel centerline to full extension of cable; the **TRAVEL** allowed by one full cable extension. See Figures 1 & 2 below.
- **Total Travel** = The **TOTAL DISTANCE** reel is to service. See Figures 1 & 2 below.
- **Payout** = The **ACTION** of cable winding off of the reel, in one or two directions. See Figures 1 & 2 below.
- **Cable Length** = The total **AMOUNT** of cable **REQUIRED** for connections, unwind/wind, SAG (if any) and “extra” lengths you require. See “[Cable Length–Don’t Cut Yourself Short](#)” at the back of this catalog.

REMEMBER: Cable Length is NEVER equal to Active Travel or Total Travel!

Fig. 1 **ONE-WAY PAYOUT**

TOTAL TRAVEL = ACTIVE TRAVEL

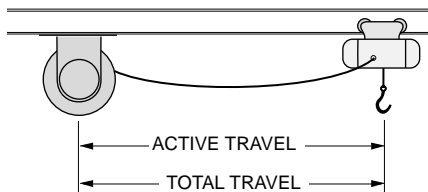
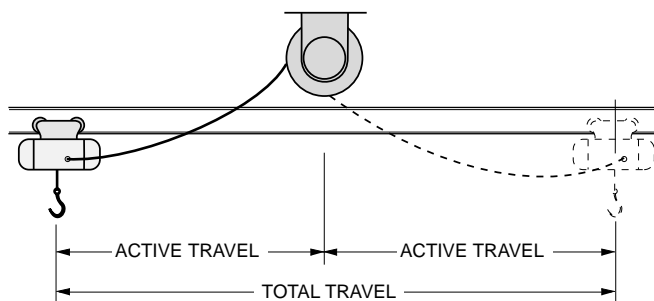

Fig. 2 **TWO-WAY PAYOUT**

TOTAL TRAVEL = ACTIVE TRAVEL x 2



Selection INPUT Required

TYPE OF APPLICATION

LIFT STRETCH RETRIEVE DRAG

If none of the above apply to how the reel will be used, or if extra weight is added at the end of the cable (overhang, push-button station, etc.), please consult your factory representative.

Active Travel _____ ft.
 Size (AWG) _____
 No. Cond. _____

INCLUDE THE FOLLOWING INFORMATION IF IT IS DIFFERENT than the cable data at the back of this catalog for the cable size listed above:

O.D. _____ Weight (lbs/ft) _____

Model Number Explanation

DIRECT DRIVE	S	16	75	1	-	8	3	-	8	-	1
	REEL TYPE	FRAME SERIES	SPRING MOTOR	No. of SPRINGS		No. of POLES	AMPACITY CODE*		CORE DIA.	GEAR RATIO	PRETENSION TURNS
GEARED DRIVE	S	21	80	2	-	12	3	-	10	B	1
	REEL TYPE	FRAME SERIES	SPRING MOTOR	No. of SPRINGS		No. of POLES	AMPACITY CODE*		CORE DIA.	GEAR RATIO	PRETENSION TURNS
CONTINUOUS CONTACT	WB	-	100	-	60						
	REEL TYPE		MAIN SPRING MOTOR MODEL		TRANSFER SPRING MOTOR MODEL						

Model No. WB-100-100-60 has two main spring motors.

*SLIP RING AMPACITY CODE

GLEASON CODE	MAX AMPS
3	35
7	75
12	125
20	200

For REVERSE ROTATION (available for all models), add the letter "R" following Spring Motor Code.
 EXAMPLES:
 S2180R - 123 - 10 - B - 1
 WB - 100 - 60R

Common Applications

HORIZONTAL STRETCH

STRETCHING cable horizontally requires the greatest amount of

tension on any application to maintain a minimum sag. In this catalog, all reel capacities for horizontal stretch applications are based on a sag of 6%.

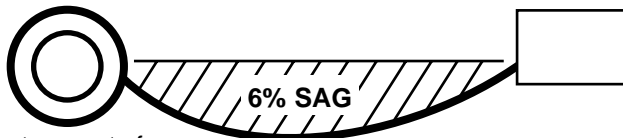

VERTICAL LIFT

VERTICAL LIFT refers to any application where the cable is simply hoisted vertically with only the weight of the cable involved. Special consideration must be given to any weight added to the end of the cable such as a push button station or overhang (i.e. extra cable).



RETRIEVE

A HORIZONTAL RETRIEVE application is identified when the reel is mounted on the moving equipment and winds and pays-out cable into tray or other support. A VERTICAL RETRIEVE application is much the same as a vertical lift except, in this case, the reel is located below rather than above the machine.

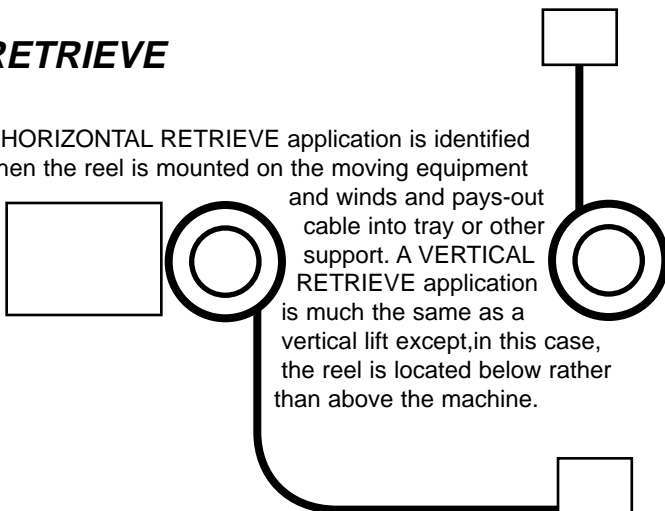

DRAG

In DRAG applications, the reel is stationary. As the machine moves, cable is pulled off of the reel and "dragged" over the surface. Dragging produces wear on the cable and is NOT a recommended application.



Lift/Drag Reels

SELECTION CHART

NOTE: Capacities based on speed of 150 ft./min. and acceleration of .50 ft./sec². Capacities based on cable of average weight and diameter. Refer to page 31.

(See "How to Select Reels" for explanation of Active Travel.)

WIRE SIZE (AWG)	No. of Cond.	FEET OF ACTIVE TRAVEL				
		30	40	50	60	70
16	2	S14-351-23-10-2	S16-351-23-12-2	S14-601-23-10-2	S16-621-23-12-1	S16-621-23-12-1
	3	S14-351-33-10-3	S16-351-33-12-3	S14-601-33-10-2	S16-621-33-12-2	S16-621-33-12-2
	4	S14-351-43-10-3	S16-351-43-12-3	S16-601-43-12-4	S16-621-43-12-2	S16-621-43-12-2
	6	S14-351-63-10-4	S16-351-63-12-4	S16-621-63-12-2	S16-621-63-11-2	S16-621-63-11-2
	8	S14-351-83-10-5	S18-351-83-13-5	S16-621-83-11-4	S16-621-83-11-4	S16-621-83-9-3
	10	S16-351-103-11-5	S16-621-103-10-6	S16-621-103-10-6	S16-621-103-8-3	S18-801-103-11-1
	12	S16-351-123-10-6	S16-801-123-10-2	S16-801-123-10-2	S18-801-123-12-2	S18-801-123-10-2
	14	S14-751-143-8-1	S16-801-143-10-2	S16-801-143-10-2	S16-801-143-8-2	S18-801-143-10-2
	16	S14-751-163-8-1	S16-801-163-9-2	S16-801-163-9-2	S16-801-163-8-2	S18-801-163-10-2
	20	S16-751-203-11-1	S16-801-203-9-2	S18-801-203-11-4	S18-801-203-9-2	S21-801-203-9-2
	24	S18-751-243-10-2	S21-751-243-13-3	S28-801-243-9-6	S24-1001-243-14-1	S28-752-243-20-1
30	S18-751-303-10-2	S21-751-303-11-2	S21-1001-303-11-1	S24-1001-303-14-2	S24-802-303-11-3	
36	S21-751-363-10-4	S21-1001-363-12-1	S21-1001-363-10-1	S24-802-363-11-6	S24-802-363-10-5	
14	2	S14-351-23-10-2	S14-351-23-10-2	S14-601-23-10-2	S16-621-23-11-1	S16-621-23-11-1
	3	S14-351-33-10-3	S16-351-33-12-3	S18-351-33-14-3	S16-621-33-11-2	S16-621-33-11-2
	4	S14-351-43-10-3	S16-351-43-12-3	S16-621-43-12-2	S16-621-43-11-3	S16-621-43-11-3
	6	S14-351-63-8-4	S16-751-63-12-1	S16-621-63-9-5	S16-621-63-8-4	S16-621-63-8-4
	8	S14-751-83-8-1	S16-801-83-10-1	S16-801-83-10-1	S16-801-83-8-1	S18-801-83-10-1
	10	S16-751-103-11-1	S16-801-103-9-1	S18-801-103-11-1	S18-801-103-9-1	S21-801-103-11-3
	12	S16-751-123-11-1	S16-801-123-9-2	S18-801-123-11-3	S18-801-123-9-2	S21-801-123-10-3
	14	S18-751-143-12-1	S18-751-143-10-1	S24-751-143-14-1	S21-801-143-10-6	S24-1001-143-16-1
	16	S18-751-163-10-1	S21-751-163-12-2	S21-1001-163-11-1	S24-1001-163-14-1	S24-802-163-11-1
	20	S21-751-203-14-6	S21-1001-203-12-1	S21-1001-203-10-1	S24-1001-203-12-1	S24-802-203-10-3
	24	S21-1001-243-11-1	S24-1001-243-11-1	S28-1001-243-11-2	S28-753-243-18-2	S28-1002-243-18-2
30	S24-1001-303-13-6	S28-752-303-13-3	S28-753-303-19-4	S28-1002-303-16-3	S28-1002-303-15-1	
12	2	S14-351-23-10-2	S16-351-23-12-2	S16-621-23-12-1	S16-621-23-11-1	S16-621-23-11-1
	3	S14-351-33-10-3	S16-351-33-12-3	S16-621-33-12-2	S16-621-33-10-2	S16-621-33-10-2
	4	S14-351-43-9-3	S16-351-43-11-3	S16-621-43-10-4	S16-621-43-10-4	S16-621-43-9-5
	6	S14-351-63-8-4	S16-801-63-9-1	S16-801-63-9-1	S16-801-63-8-1	S18-801-63-10-1
	8	S16-751-83-11-1	S16-801-83-9-1	S18-801-83-11-2	S18-801-83-9-1	S21-801-83-9-1
	10	S18-751-103-10-1	S21-751-103-13-1	S21-801-103-9-6	S21-801-103-9-6	S28-1001-103-17-1
	12	S18-751-123-10-1	S21-751-123-13-3	S21-1001-123-11-1	S24-1001-123-14-1	S24-802-123-14-6
	14	S18-751-143-10-1	S21-751-143-12-3	S21-1001-143-10-1	S24-1001-143-13-1	S24-802-143-11-4
	16	S21-751-163-14-6	S21-1001-163-12-1	S21-1001-163-10-1	S24-1001-163-12-1	S24-802-163-10-4
	20	S21-1001-203-11-1	S24-1001-203-12-5	S24-752-203-12-1	S28-753-203-16-1	S28-1002-203-17-2
	24	S24-1001-243-12-2	S28-752-243-13-4	S28-753-243-16-3	S28-1002-243-14-2	S28-804-243-13-6
10	2	S14-351-23-10-2	S16-351-23-12-3	S16-621-23-11-4	S16-621-23-11-4	S16-621-23-9-1
	3	S14-351-33-9-3	S16-751-33-12-1	S16-621-33-8-3	S16-621-33-8-3	S16-621-33-8-3
	4	S14-351-43-8-3	S16-801-43-10-1	S16-801-43-10-1	S16-801-43-8-1	S18-801-43-10-1
	6	S16-751-63-11-1	S16-801-63-9-1	S18-801-63-11-2	S18-801-63-9-1	S21-801-63-10-2
	8	S18-751-83-10-1	S21-751-83-13-3	S21-801-83-9-6	S24-1001-83-14-1	S24-802-83-14-6
	10	S21-751-103-15-6	S21-751-103-12-3	S21-1001-103-10-1	S24-1001-103-13-1	S24-802-103-10-1
	12	S21-751-123-14-6	S21-1001-123-12-1	S21-1001-123-10-1	S24-1001-123-12-1	S24-802-123-10-4
	20	S21-1001-143-11-1	S24-1001-143-11-4	S24-752-143-12-1	S28-753-143-16-1	S28-803-143-11-5
8	2W	S14-351-27-8-3	S16-801-27-10-1	S16-801-27-10-1	S16-801-27-8-1	S18-801-27-10-1
	3W	S16-751-37-11-1	S16-801-37-9-1	S18-801-37-11-2	S18-801-37-9-1	S21-801-37-11-4
	3G	S16-751-47-11-1	S16-801-47-9-1	S18-801-47-9-3	S18-801-47-9-3	S21-801-47-8-1
	4W	S16-751-47-9-1	S16-801-47-9-1	S18-801-47-8-1	S21-801-47-10-6	S21-801-47-8-1
6	2W	S16-751-27-11-1	S16-801-27-9-1	S18-801-27-11-1	S18-801-27-9-1	S21-801-27-12-5
	3W	S16-751-37-8-1	S16-801-37-8-1	S18-801-37-8-1	S18-801-37-8-1	S21-801-37-8-1
	3G	S18-751-47-10-1	S21-751-47-11-2	S21-1001-47-11-1	S24-1001-47-14-2	S21-802-47-9-1
	4W	S18-751-47-10-1	S21-751-47-11-2	S21-1001-47-11-1	S24-1001-47-14-2	S24-802-47-11-4
4	2W	S18-751-212-10-1	S21-751-212-11-2	S21-1001-212-11-1	S24-1001-212-13-1	S24-802-212-11-5
	3W	S18-751-312-10-1	S21-751-312-11-2	S21-1001-312-11-1	S24-1001-312-13-1	S24-802-312-11-5
	3G	S21-751-412-10-4	S21-1001-412-12-1	S21-1001-412-10-1	S28-753-412-18-2	S24-803-412-13-6
	4W	S21-751-412-10-4	S21-1001-412-12-1	S21-1001-412-10-1	S28-802-412-10-5	S24-803-412-13-5
2	2W	S21-1001-212-11-1	S24-1001-212-11-4	S24-752-212-12-2	S28-1002-212-18-4	S28-803-212-11-5
	3W	S21-1001-312-14-1	S21-1001-312-12-2	S24-1001-312-10-1	S28-753-312-18-2	S28-1002-312-17-2
	3G	S21-1001-412-11-1	S24-753-412-11-1	S28-753-412-14-2	S28-804-412-11-5	S28-804-412-11-5
	4W	S21-1001-412-11-1	S24-752-412-11-3	S28-753-412-14-2	S28-1002-412-14-2	S28-804-412-12-6
1	2W	S21-1001-220-11-1	S24-1001-220-11-3	S28-753-220-20-4	S28-753-220-16-1	S28-1002-220-15-1
	3W	S24-752-320-13-6	S28-753-320-19-6	S28-753-320-13-2	S28-1002-320-13-2	S28-1003-320-15-1
	3G	S24-753-420-13-4	S28-1002-420-14-6	S28-754-420-13-2	S28-1003-420-14-3	S28-1004-420-14-1
1/0	2W	S24-1001-220-12-6	S28-753-220-20-6	S28-753-220-15-3	S28-1002-220-13-1	S28-804-220-12-5

Lift/Drag Reels Continued

COMPLETE DIMENSIONAL DATA is available on the following pages. Refer to the first three digits of the model number.

*** TRAVELS GREATER THAN 120 FEET ARE POSSIBLE** for those wire sizes with a ✓ next to them. Consult factory for additional reel models.

FEET OF ACTIVE TRAVEL					No. of Cond.	WIRE SIZE (AWG)	
80	90	100	110	120*			
S16-621-23-12-1	S16-621-23-12-1	S18-621-23-14-1	S21-621-23-17-2	S21-621-23-17-2	2✓	16	
S16-621-33-12-2	S16-621-33-12-2	S18-621-33-14-2	S21-621-33-17-5	S28-801-33-24-1	3✓		
S16-621-43-12-2	S16-621-43-12-2	S18-621-43-14-3	S24-801-43-20-1	S24-801-43-20-1	4✓		
S16-621-63-10-2	S18-621-63-12-4	S21-801-63-16-1	S24-801-63-19-1	S28-801-63-21-2	6✓		
S18-621-83-10-4	S21-801-83-16-1	S24-801-83-19-4	S24-801-83-17-1	S24-622-83-15-2	8✓		
S21-801-103-14-1	S21-801-103-14-1	S21-622-103-14-5	S24-622-103-13-3	S28-802-103-21-1	10✓		
S21-801-123-13-2	S24-801-123-15-3	S21-622-123-11-2	S28-802-123-21-1	S28-802-123-21-1	12✓		
S21-801-143-13-3	S21-622-143-10-3	S24-802-143-16-1	S24-802-143-16-1	S28-802-143-20-2	14✓		
S18-622-163-10-5	S21-802-163-13-1	S24-802-163-16-1	S24-802-163-16-1	S28-803-163-21-1	16✓		
S28-1001-203-20-1	S24-802-203-15-1	S28-802-203-17-3	S28-803-203-21-2	S28-803-203-21-2	20✓		
S24-802-243-12-2	S24-803-243-10-1	S28-803-243-20-6	S28-803-243-18-3	S28-803-243-17-1	24✓		
S24-802-303-11-3	S28-803-303-17-5	S28-803-303-16-3	S28-804-303-17-1	S28-804-303-17-1	30✓		
S28-1002-363-19-1	S28-803-363-13-3	S28-804-363-16-2	S28-804-363-16-2	S28-1004-363-13-C-1	36✓		
S16-621-23-11-1	S18-621-23-13-2	S21-801-23-16-1	S24-801-23-19-1	S28-801-23-24-4	2✓		14
S16-621-33-11-2	S18-621-33-12-3	S21-801-33-16-1	S24-801-33-19-1	S28-801-33-21-2	3✓		
S18-621-43-11-5	S21-801-43-16-1	S21-801-43-16-1	S24-801-43-18-1	S24-622-43-15-1	4✓		
S21-801-63-15-1	S21-801-63-15-1	S24-801-63-15-1	S28-802-63-22-1	S28-802-63-22-1	6✓		
S21-801-83-13-3	S21-622-83-10-3	S24-802-83-16-1	S28-802-83-20-3	S28-802-83-19-1	8✓		
S21-801-103-10-1	S21-622-103-8-2	S28-802-103-19-5	S28-802-103-17-1	S28-803-103-21-1	10✓		
S28-1001-123-20-1	S24-802-123-15-1	S28-802-123-17-3	S28-803-123-21-2	S28-803-123-21-2	12✓		
S24-802-143-14-1	S24-802-143-14-1	S28-802-143-14-1	S28-803-143-20-4	S32-803-143-18-1	14✓		
S24-802-163-11-1	S28-803-163-18-5	S28-803-163-17-4	S28-803-163-16-2	S28-804-163-17-1	16✓		
S28-802-203-10-1	S28-803-203-14-3	S28-803-203-13-1	S28-804-203-16-1	S28-1004-203-13-C-1	20✓		
S28-803-243-13-6	S28-803-243-11-2	S28-804-243-12-1	S28-1004-243-12-C-2		24		
S28-804-303-13-5	S32-1004-303-21-1				30		
S16-621-23-9-1	S18-621-23-11-2	S21-801-23-16-1	S24-801-23-19-1	S24-622-23-17-4	2✓	12	
S18-621-33-10-3	S21-801-33-16-1	S21-801-33-16-1	S21-622-33-14-1	S24-802-33-19-1	3✓		
S16-622-43-9-1	S21-801-43-14-1	S24-801-43-16-2	S21-622-43-13-1	S28-802-43-24-1	4✓		
S21-801-63-13-3	S21-622-63-9-1	S24-802-63-16-1	S24-802-63-16-1	S28-803-63-21-1	6✓		
S21-622-83-8-2	S24-802-83-15-1	S28-802-83-17-3	S28-802-83-16-1	S28-803-83-21-2	8✓		
S24-802-103-12-1	S24-802-103-10-1	S28-803-103-20-6	S28-803-103-18-3	S28-803-103-17-1	10✓		
S24-802-123-11-1	S28-803-123-18-4	S28-803-123-17-3	S28-803-123-16-2	S28-804-123-17-1	12✓		
S24-802-143-11-4	S28-803-143-17-6	S28-803-143-14-2	S28-804-143-17-1	S28-804-143-17-1	14✓		
S28-1002-163-19-1	S28-803-163-13-2	S28-804-163-19-6	S28-804-163-16-2	S28-1004-163-13-C-1	16✓		
S28-803-203-12-5	S28-804-203-14-4	S28-804-203-12-1	S28-1004-203-11-C-1		20		
S32-804-243-12-6					24		
S16-621-23-9-1	S21-801-23-16-1	S24-801-23-18-3	S24-801-23-17-1	S24-622-23-14-1	2✓		10
S16-622-33-9-1	S21-801-33-14-1	S21-622-33-13-3	S24-802-33-17-1	S28-802-33-24-3	3✓		
S21-801-43-13-1	S21-801-43-13-1	S21-622-43-11-2	S28-802-43-21-3	S28-802-43-20-1	4✓		
S21-622-63-8-4	S24-802-63-15-1	S28-802-63-17-3	S28-803-63-21-2	S28-803-63-21-2	6✓		
S24-802-83-11-1	S28-803-83-18-4	S28-803-83-17-3	S28-803-83-16-1	S28-804-83-17-1	8✓		
S28-802-103-10-1	S28-803-103-17-6	S28-803-103-14-2	S28-804-103-17-1	S28-804-103-17-1	10✓		
S28-1002-123-19-1	S28-803-123-13-2	S28-804-123-19-6	S28-804-123-16-2	S28-1004-123-13-C-1	12✓		
S28-804-143-14-6	S28-804-143-13-4	S28-1004-143-15-B-2			14		
S32-1004-203-18-1					20		
S21-801-27-13-1	S21-801-27-13-1	S21-622-27-11-3	S24-802-27-16-1	S28-802-27-21-2	2W✓	8	
S21-622-37-9-6	S24-802-37-15-1	S28-802-37-18-4	S24-623-37-10-1	S28-803-37-21-1	3W✓		
S21-802-47-10-1	S24-802-47-15-4	S24-802-47-13-1	S28-803-47-19-3	S28-803-47-18-1	3G✓		
S24-802-47-14-1	S24-802-47-12-1	S24-623-47-8-1	S28-803-47-20-4	S32-803-47-18-1	4W✓		
S21-801-27-10-1	S21-622-27-8-1	S28-802-27-19-4	S28-802-27-18-2	S28-803-27-21-1	2W✓	6	
S24-802-37-14-2	S24-802-37-12-1	S24-623-37-8-1	S28-803-37-18-1	S28-804-37-20-1	3W✓		
S24-802-47-11-3	S24-802-47-10-1	S28-803-47-14-1	S28-804-47-18-3	S28-804-47-17-1	3G✓		
S24-802-47-11-4	S28-803-47-17-6	S28-804-47-17-1	S28-804-47-17-1	S28-804-47-17-1	4W✓		
S24-802-212-9-1	S28-803-212-16-5	S28-804-212-17-2	S28-804-212-17-2	S28-804-212-9-B-2	2W✓	4	
S24-802-312-9-1	S28-803-312-16-5	S28-804-312-17-2	S28-804-312-17-2	S28-804-312-9-B-2	3W✓		
S24-803-412-10-1	S28-803-412-10-1	S28-804-412-13-2	S28-1004-412-11-C-1		3G		
S28-803-412-12-3	S28-803-412-11-1	S28-804-412-14-2	S28-1004-412-16-B-1		4W		
S28-804-212-14-6	S28-804-212-13-4				2W	2	
S28-803-312-11-4	S28-804-312-13-3	S28-804-312-12-1	S28-1004-312-10-C-1		3W		
S28-1004-412-18-1	S28-1004-412-11-B-1				3G		
S28-804-412-11-4	S32-1004-412-21-1				4W		
S28-804-220-14-6	S28-804-220-13-4	S28-804-220-11-1			2W	1	
S32-1004-320-19-1	S32-1004-320-19-1				3W		
					3G		
S32-1004-220-18-1					2W	1/0	

Stretch Reels

SELECTION CHART

NOTE: Capacities based on 6% sag, speed of 150 ft./min. and acceleration of .75 ft./sec.². Capacities based on cable of average weight and diameter. [Refer to page 31.](#)

(See "How to Select Reels" for explanation of Active Travel.)

WIRE SIZE (AWG)	No. of Cond.	FEET OF ACTIVE TRAVEL				
		30	40	50	60	70
16	2	S14-351-23-10-2	S16-351-23-12-3	S14-601-23-10-2	S16-621-23-12-2	S16-621-23-12-2
	3	S14-351-33-10-3	S16-351-33-12-3	S16-621-33-12-2	S16-621-33-12-2	S16-621-33-12-2
	4	S14-351-43-10-3	S16-351-43-12-3	S16-621-43-11-6	S16-621-43-11-6	S16-621-43-11-6
	6	S14-351-63-10-4	S16-751-63-12-1	S16-621-63-9-5	S16-621-63-9-5	S16-621-63-8-2
	8	S14-751-83-10-1	S16-751-83-12-1	S16-801-83-11-1	S16-801-83-11-1	S18-801-83-13-1
	10	S14-751-103-8-1	S16-801-103-10-1	S16-801-103-10-1	S16-801-103-9-1	S18-801-103-11-1
	12	S14-751-123-8-1	S16-801-123-10-2	S16-801-123-10-2	S18-801-123-12-5	S18-801-123-10-2
	14	S14-751-143-8-1	S16-801-143-10-2	S16-801-143-10-2	S16-801-143-8-2	S18-622-143-8-4
	16	S14-751-163-8-1	S16-801-163-9-2	S16-801-163-9-2	S16-801-163-8-2	S24-1001-163-17-1
	20	S16-751-203-11-1	S16-801-203-9-5	S18-801-203-8-4	S21-1001-203-14-1	S21-802-203-12-1
	24	S18-751-243-10-2	S21-1001-243-13-1	S21-1001-243-11-1	S21-802-243-9-2	S21-802-243-9-2
30	S18-751-303-10-4	S21-1001-303-13-1	S21-1001-303-11-1	S24-802-303-10-6	S24-802-303-9-4	
36	S21-1001-363-14-1	S21-1001-363-12-5	S24-752-363-12-1	S24-1002-363-13-1	S24-803-363-10-2	
14	2	S14-351-23-10-2	S14-351-23-10-2	S16-621-23-10-4	S16-621-23-10-4	S16-621-23-10-4
	3	S14-351-33-10-3	S16-751-33-12-1	S16-621-33-9-4	S16-621-33-9-4	S16-801-33-11-1
	4	S14-351-43-10-4	S16-751-43-12-1	S16-621-43-8-5	S16-621-43-8-5	S16-801-43-11-1
	6	S14-751-63-8-1	S16-751-63-12-1	S16-801-63-10-1	S16-801-63-10-1	S18-801-63-12-4
	8	S14-751-83-8-1	S16-801-83-10-2	S16-801-83-10-2	S16-801-83-8-1	S18-622-83-8-4
	10	S16-751-103-11-1	S16-801-103-9-2	S18-801-103-9-5	S21-801-103-8-2	S21-802-103-12-1
	12	S16-751-123-11-1	S16-801-123-9-4	S18-801-123-9-6	S21-1001-123-14-1	S21-802-123-12-1
	14	S18-751-143-12-1	S18-751-143-10-1	S21-1001-143-13-1	S21-802-143-11-2	S21-802-143-11-2
	16	S18-751-163-10-2	S21-1001-163-13-1	S21-1001-163-11-1	S21-802-163-11-5	S24-802-163-10-5
	20	S21-1001-203-15-1	S21-1001-203-12-1	S21-1001-203-10-1	S28-802-203-10-6	S24-803-203-13-6
	24	S21-1001-243-11-1	S24-1001-243-11-5	S28-753-243-17-3	S28-1002-243-16-3	S28-803-243-11-6
30	S24-752-303-13-6	S28-753-303-17-5	S28-753-303-13-1	S28-1003-303-17-2	S28-1003-303-17-2	
12	2	S14-351-23-10-2	S16-751-23-12-1	S16-621-23-9-6	S16-621-23-9-6	S16-621-23-8-2
	3	S14-351-33-10-5	S16-751-33-12-1	S16-621-33-8-6	S16-801-33-11-1	S16-801-33-11-1
	4	S14-351-43-8-3	S16-751-43-12-1	S16-801-43-10-1	S16-801-43-10-1	S18-801-43-12-2
	6	S14-751-63-8-1	S16-801-63-9-1	S16-801-63-9-1	S16-801-63-8-1	S18-801-63-9-1
	8	S16-751-83-11-1	S16-801-83-9-3	S18-801-83-9-6	S21-801-83-8-3	S21-802-83-12-1
	10	S18-751-103-10-1	S21-751-103-11-2	S21-1001-103-11-1	S24-1001-103-13-1	S21-802-103-9-1
	12	S18-751-123-10-1	S21-1001-123-13-1	S21-1001-123-11-1	S21-802-123-11-4	S24-802-123-11-6
	14	S18-751-143-10-4	S21-1001-143-13-2	S21-1001-143-10-1	S24-802-143-9-4	S24-802-143-9-4
	16	S21-1001-163-14-1	S21-1001-163-12-3	S21-1001-163-10-1	S24-1002-163-13-1	S24-803-163-10-1
	20	S21-1001-203-11-1	S24-752-203-11-2	S24-753-203-12-1	S28-1002-203-15-2	S28-804-203-12-5
	24	S24-752-243-13-6	S28-753-243-16-5	S28-753-243-13-2	S28-1003-243-17-1	S28-1003-243-14-1
10	2	S14-351-23-10-5	S16-751-23-12-1	S16-801-23-11-1	S16-801-23-11-1	S18-801-23-13-2
	3	S14-351-33-8-4	S16-751-33-12-1	S16-801-33-10-1	S16-801-33-10-1	S18-801-33-11-1
	4	S14-751-43-8-1	S16-801-43-10-1	S16-801-43-10-1	S16-801-43-8-1	S18-801-43-10-2
	6	S16-751-63-11-1	S16-801-63-9-3	S18-801-63-9-6	S21-801-63-8-3	S21-802-63-12-1
	8	S18-751-83-10-1	S21-1001-83-13-1	S21-1001-83-11-1	S21-802-83-11-4	S24-802-83-11-6
	10	S21-751-103-10-4	S21-1001-103-12-1	S21-1001-103-10-1	S28-802-103-10-5	S24-803-103-10-1
	12	S21-1001-123-15-1	S21-1001-123-12-3	S21-1001-123-10-1	S24-1002-123-13-1	S24-803-123-10-1
	14	S21-1001-143-11-1	S24-752-143-11-3	S24-753-143-12-1	S28-1002-143-14-2	S28-804-143-12-6
	20	S24-753-203-13-1	S28-753-203-13-4	S28-1002-203-13-4	S28-1003-203-17-4	S28-1003-203-14-1
	8	2W	S14-751-27-8-1	S16-801-27-10-1	S16-801-27-10-1	S16-801-27-8-1
3W		S16-751-37-11-1	S16-801-37-9-3	S18-801-37-9-5	S21-801-37-8-3	S21-802-37-12-1
3G		S16-751-47-11-1	S18-801-47-8-6	S18-801-47-8-6	S18-802-47-9-1	S21-802-47-12-5
4W		S16-751-47-9-1	S16-801-47-8-4	S18-801-47-8-6	S21-802-47-11-2	S21-802-47-11-2
6	2W	S16-751-27-11-1	S16-801-27-9-1	S18-801-27-9-3	S18-801-27-9-3	S21-801-27-8-1
	3W	S16-751-37-8-1	S16-801-37-8-5	S21-1001-37-13-1	S18-802-37-8-1	S21-802-37-11-3
	3G	S18-751-47-10-3	S21-1001-47-13-1	S21-1001-47-11-1	S21-802-47-9-3	S21-802-47-9-3
	4W	S18-751-47-10-3	S21-1001-47-13-2	S21-1001-47-11-1	S24-802-47-9-4	S24-802-47-9-4
4	2W	S18-751-212-10-4	S21-1001-212-13-5	S21-1001-212-11-2	S24-802-212-9-5	S24-803-212-11-3
	3W	S18-751-312-10-4	S21-1001-312-13-5	S21-1001-312-11-2	S24-802-312-9-5	S24-803-312-11-2
	3G	S21-1001-412-14-6	S21-752-412-12-3	S24-753-412-14-1	S24-1002-412-13-1	S24-804-412-10-1
	4W	S21-1001-412-14-2	S21-1001-412-10-3	S24-753-412-15-1	S24-1002-412-13-1	S24-803-412-10-5
2	2W	S21-1001-212-11-1	S24-752-212-11-3	S24-753-212-12-1	S28-1002-212-14-2	S28-804-212-12-6
	3W	S21-1001-312-11-6	S21-1001-312-10-4	S24-753-312-14-2	S24-1002-312-12-1	S28-804-312-12-6
	3G	S21-752-412-11-5	S24-753-412-11-2	S28-1002-412-11-1	S28-1003-412-15-2	S28-1004-412-17-1
	4W	S21-752-412-11-3	S24-753-412-11-1	S28-1002-412-12-2	S28-1003-412-16-3	S28-1004-412-18-2
1	2W	S21-1001-220-11-1	S24-752-220-11-3	S28-753-220-14-2	S28-1002-220-14-2	S28-804-220-12-6
	3W	S24-753-320-13-2	S28-753-320-12-3	S28-754-320-15-3	S28-1003-320-15-3	S28-1004-320-15-1
	3G	S24-753-420-13-6	S28-754-420-13-4	S28-1003-420-15-5	S28-1004-420-14-1	S28-1004-420-14-1
1/0	2W	S24-753-220-13-1	S28-753-220-14-4	S28-1002-220-13-4	S28-1003-220-17-3	S28-1003-220-14-1

Stretch Reels Continued

COMPLETE DIMENSIONAL DATA is available on the following pages. Refer to the first three digits of the model number.

* TRAVELS GREATER THAN 120 FEET ARE POSSIBLE for those wire sizes with a ✓ next to them. Consult factory for additional reel models.

FEET OF ACTIVE TRAVEL					No. of Cond.	WIRE SIZE (AWG)	
80	90	100	110	120*			
S16-621-23-12-2	S16-621-23-12-2	S21-801-23-17-1	S24-801-23-20-1	S28-801-23-24-4	2✓	16	
S16-621-33-12-2	S16-621-33-12-2	S21-801-33-17-1	S24-801-33-20-1	S21-622-33-17-1	3✓		
S18-801-43-14-1	S16-622-43-12-1	S21-801-43-17-1	S18-622-43-14-1	S24-802-43-20-1	4✓		
S18-801-63-13-1	S21-801-63-16-3	S18-622-63-12-1	S24-802-63-19-1	S28-802-63-24-3	6✓		
S16-622-83-9-2	S18-622-83-11-2	S24-802-83-19-1	S24-802-83-17-1	S28-802-83-20-1	8✓		
S18-622-103-9-2	S21-802-103-14-1	S24-802-103-17-1	S24-802-103-17-1	S28-803-103-21-1	10✓		
S18-622-123-8-2	S21-802-123-13-1	S24-802-123-16-1	S28-803-123-21-2	S28-803-123-21-2	12✓		
S21-802-143-13-1	S21-802-143-13-1	S24-803-143-16-1	S24-803-143-16-1	S28-803-143-19-1	14✓		
S21-802-163-13-1	S21-802-163-13-1	S24-803-163-16-1	S24-803-163-16-1	S28-804-163-21-1	16✓		
S21-802-203-10-1	S24-803-203-15-1	S28-803-203-16-2	S28-804-203-21-5	S28-804-203-18-1	20✓		
S24-802-243-10-3	S24-803-243-10-1	S28-804-243-18-5	S28-804-243-16-1	S28-1004-243-18-B-1	24✓		
S24-803-303-11-1	S28-804-303-17-6	S28-804-303-14-1	S28-1004-303-16-B-1	S28-1004-303-9-K-1	30		
S28-804-363-15-6	S28-804-363-13-3	S28-1004-363-19-A-1			36		
S18-801-23-13-1	S21-801-23-16-1	S21-801-23-16-1	S21-622-23-14-1	S28-802-23-24-1	2✓		14
S18-801-33-13-1	S21-801-33-16-3	S18-622-33-12-1	S24-802-33-19-1	S28-802-33-24-4	3✓		
S18-801-43-13-1	S18-622-43-11-1	S21-802-43-16-1	S24-802-43-19-1	S28-802-43-20-1	4✓		
S18-622-63-9-1	S21-802-63-15-1	S24-802-63-18-4	S21-624-63-13-1	S28-803-63-22-3	6✓		
S21-802-83-13-1	S21-802-83-13-1	S24-803-83-16-1	S28-803-83-19-2	S28-804-83-21-1	8✓		
S21-802-103-10-1	S24-802-103-13-2	S28-803-103-18-4	S28-804-103-21-4	S28-804-103-18-1	10✓		
S21-802-123-10-1	S24-803-123-15-1	S28-803-123-16-2	S28-804-123-20-4	S28-804-123-18-1	12✓		
S24-802-143-11-3	S24-803-143-14-1	S28-803-143-14-1	S28-804-143-17-2	S28-804-143-9-B-1	14✓		
S24-802-163-9-2	S28-803-163-12-1	S28-804-163-15-2	S28-1004-163-17-B-1	S28-1004-163-13-C-1	16		
S28-803-203-11-2	S28-804-203-14-3	S28-804-203-13-1	S28-1004-203-11-C-1		20		
S28-804-243-13-6	S28-804-243-11-2				24		
S32-1004-303-20-2					30		
S18-801-23-13-1	S21-801-23-14-1	S21-622-23-12-2	S24-802-23-19-1	S28-802-23-23-4	2✓	12	
S18-801-33-13-1	S18-622-33-11-2	S21-802-33-16-1	S24-802-33-19-1	S24-802-33-19-1	3✓		
S16-622-43-9-1	S21-802-43-14-1	S24-802-43-18-2	S24-802-43-17-1	S28-803-43-24-4	4✓		
S21-802-63-13-1	S21-802-63-13-1	S24-803-63-16-1	S24-803-63-16-1	S28-804-63-21-1	6✓		
S24-802-83-13-4	S24-803-83-15-1	S28-803-83-16-2	S28-804-83-21-5	S28-804-83-18-1	8✓		
S24-802-103-10-2	S24-803-103-10-1	S28-804-103-18-5	S28-804-103-16-1	S28-804-103-9-B-1	10✓		
S24-802-123-9-2	S28-803-123-13-2	S28-804-123-16-3	S28-804-123-15-1	S28-1004-123-13-C-1	12		
S24-803-143-11-1	S28-804-143-15-4	S28-804-143-14-2	S28-1004-143-16-B-1		14		
S28-803-163-11-3	S28-804-163-13-2	S28-1004-163-19-A-1			16		
S28-804-203-12-5	S32-1004-203-21-1				20		
S32-1004-243-18-1					24		
S16-622-23-9-1	S18-622-23-11-3	S24-802-23-19-1	S24-802-23-17-1	S28-803-23-24-1	2✓		10
S16-622-33-9-1	S21-802-33-14-1	S24-802-33-17-2	S24-803-33-17-1	S28-803-33-22-3	3✓		
S21-802-43-13-1	S21-802-43-13-1	S21-623-43-10-1	S28-803-43-20-3	S28-804-43-21-1	4✓		
S21-802-63-10-1	S24-803-63-15-1	S28-803-63-16-2	S28-804-63-21-5	S28-804-63-18-1	6✓		
S24-802-83-9-2	S28-803-83-13-2	S28-804-83-16-3	S28-804-83-15-1	S28-1004-83-13-C-1	8		
S28-803-103-12-3	S28-804-103-15-4	S28-804-103-14-2	S28-1004-103-11-C-1		10		
S28-803-123-10-1	S28-804-123-13-2	S28-1004-123-19-A-1			12		
S28-804-143-11-4	S28-1004-143-11-B-1				14		
S32-1004-203-17-1					20		
S18-622-27-8-1	S21-802-27-13-1	S24-802-27-16-2	S24-803-27-16-1	S28-803-27-21-3	2W✓	8	
S21-802-37-10-1	S24-802-37-12-1	S28-803-37-17-3	S28-804-37-21-5	S28-804-37-18-1	3W✓		
S21-802-47-10-1	S24-803-47-13-1	S24-803-47-13-1	S28-804-47-16-1	S24-804-47-9-B-2	3G✓		
S24-802-47-10-1	S24-803-47-12-1	S24-624-47-8-1	S28-804-47-17-2	S24-804-47-8-B-1	4W✓		
S21-802-27-10-1	S24-802-27-13-2	S28-803-27-19-5	S28-803-27-17-1	S28-804-27-21-3	2W✓	6	
S24-802-37-10-1	S24-803-37-12-1	S28-804-37-17-3	S28-804-37-16-1	S28-804-37-9-B-1	3W✓		
S24-803-47-12-4	S24-803-47-10-1	S28-804-47-11-A-2	S28-1004-47-12-C-1		3G		
S24-803-47-11-1	S28-804-47-15-4	S28-804-47-10-A-1	S28-1004-47-10-J-1		4W		
S24-803-212-11-3	S28-804-212-14-3	S28-804-212-10-A-1	S28-1004-212-10-J-1		2W	4	
S24-803-312-11-2	S28-804-312-14-3	S28-804-312-10-A-1	S28-1004-312-10-J-1		3W		
S24-804-412-10-1	S28-804-412-10-1				3G		
S28-804-412-12-3	S28-804-412-11-1				4W		
S28-804-212-11-4	S28-1004-212-11-B-1				2W	2	
S28-804-312-11-4	S28-1004-312-11-B-1				3W		
S28-1004-412-13-A-1					3G		
S28-1004-412-13-A-1					4W		
S28-804-220-11-4	S28-1004-220-11-B-1				2W	1	
					3W		
					3G		
S32-1004-220-17-1					2W	1/0	

Retrieve Reels

SELECTION CHART

NOTE: Capacities based on 3 ft. lift to center line of reel, speed of 150 ft./min. and acceleration of 1.0 ft./sec². Capacities based on cable of average weight and diameter. Refer to page 31.

(See "How to Select Reels" for explanation of Active Travel.)

WIRE SIZE (AWG)	No. of Cond.	FEET OF ACTIVE TRAVEL					
		30	40	50	60	70	80
16	2	S14-351-23-10-3	S16-351-23-12-3	S16-601-23-12-3	S16-621-23-12-2	S16-621-23-12-2	S16-621-23-12-2
	3	S14-351-33-10-3	S16-351-33-12-3	S16-601-33-12-3	S16-621-33-12-2	S16-621-33-12-2	S16-621-33-12-2
	4	S14-351-43-10-4	S14-601-43-10-3	S16-601-43-12-4	S16-621-43-12-2	S16-621-43-12-2	S16-621-43-12-2
	6	S14-351-63-10-5	S14-601-63-9-4	S16-601-63-12-4	S16-621-63-11-3	S16-621-63-11-3	S16-621-63-10-3
	8	S14-351-83-10-5	S14-601-83-9-5	S16-621-83-11-3	S16-621-83-11-3	S16-621-83-9-3	S16-621-83-11-3
	10	S14-601-103-8-6	S16-621-103-10-4	S16-621-103-10-4	S16-621-103-9-4	S16-621-103-9-4	S18-621-103-11-5
	12	S14-751-123-8-1	S16-621-123-10-5	S16-621-123-10-5	S16-621-123-8-5	S18-621-123-10-6	S21-621-123-12-6
	14	S14-751-143-8-1	S16-621-143-10-6	S16-621-143-10-6	S16-621-143-8-6	S18-621-143-10-2	S21-621-143-13-2
	16	S14-751-163-8-1	S16-801-163-9-2	S16-801-163-9-2	S18-801-163-8-2	S18-801-163-10-2	S18-801-163-13-2
	20	S16-751-203-11-2	S16-801-203-9-3	S18-801-203-11-3	S18-801-203-9-3	S21-801-203-12-3	S24-801-203-15-3
	24	S18-751-243-10-2	S21-751-243-13-2	S24-751-243-16-2	S21-801-243-9-3	S21-801-243-9-3	S24-801-243-12-4
30	S18-751-303-10-2	S21-751-303-13-2	S24-751-303-16-2	S21-801-303-11-5	S24-801-303-14-6	S24-802-303-11-2	
36	S21-751-363-14-3	S21-751-363-12-3	S28-751-363-21-4	S28-1001-363-21-2	S28-1001-363-19-2	S32-1001-363-23-2	
14	2	S14-351-23-10-3	S16-351-23-12-3	S14-601-23-10-3	S16-621-23-11-2	S16-621-23-11-2	S16-621-23-11-2
	3	S14-351-33-10-4	S16-351-33-12-4	S16-601-33-12-3	S16-621-33-11-2	S16-621-33-11-2	S16-621-33-11-2
	4	S14-351-43-10-4	S16-351-43-12-4	S16-601-43-12-4	S16-621-43-11-2	S16-621-43-11-2	S18-621-43-13-3
	6	S16-351-63-12-5	S16-601-63-12-5	S16-621-63-10-3	S16-621-63-10-3	S16-621-63-8-3	S16-621-63-10-3
	8	S16-351-83-10-6	S16-621-83-10-4	S16-621-83-10-4	S16-621-83-8-4	S18-621-83-10-5	S21-621-83-13-6
	10	S16-751-103-11-1	S16-621-103-9-5	S18-621-103-11-6	S18-621-103-9-6	S21-621-103-8-6	S24-801-103-15-2
	12	S16-751-123-11-1	S16-621-123-9-6	S18-621-123-11-2	S18-801-123-9-2	S21-801-123-12-2	S24-801-123-15-3
	14	S18-751-143-12-2	S18-801-143-10-2	S24-751-143-16-2	S21-801-143-11-3	S21-801-143-11-3	S24-801-143-14-3
	16	S18-751-163-10-2	S21-751-163-13-2	S24-751-163-16-2	S21-801-163-11-3	S24-801-163-14-3	S24-801-163-11-3
	20	S21-751-203-15-2	S21-751-203-12-2	S24-751-203-15-2	S28-751-203-22-2	S28-751-203-22-2	S28-801-203-18-6
	24	S21-751-243-11-2	S24-751-243-11-2	S28-751-243-21-3	S28-1001-243-18-2	S28-1001-243-18-2	S32-1001-243-22-2
30	S24-751-303-13-3	S28-751-303-20-4	S28-751-303-20-4	S28-1001-303-17-2	S28-1001-303-17-2	S32-1001-303-21-2	
12	2	S14-351-23-10-3	S16-351-23-12-4	S16-601-23-12-3	S16-621-23-11-2	S16-621-23-11-2	S18-621-23-13-2
	3	S14-351-33-10-4	S16-351-33-12-4	S16-601-33-12-4	S16-621-33-11-2	S16-621-33-11-2	S18-621-33-13-3
	4	S14-351-43-9-4	S14-601-43-9-4	S16-621-43-10-3	S16-621-43-10-3	S16-621-43-9-3	S18-621-43-11-3
	6	S16-351-63-11-6	S16-601-63-9-5	S16-621-63-9-3	S16-621-63-8-3	S18-621-63-10-4	S18-621-63-10-4
	8	S16-751-83-11-1	S16-621-83-9-5	S18-621-83-11-5	S18-621-83-9-5	S21-621-83-11-6	S21-621-83-9-6
	10	S18-751-103-10-1	S21-751-103-13-2	S24-751-103-16-2	S21-801-103-11-2	S21-801-103-9-2	S24-801-103-12-3
	12	S18-751-123-10-2	S21-751-123-13-2	S24-751-123-16-2	S21-801-123-11-3	S24-801-123-14-3	S18-621-123-11-3
	14	S18-751-143-10-2	S21-751-143-13-2	S24-751-143-16-2	S28-751-143-22-2	S28-751-143-22-2	S24-801-143-11-3
	16	S21-751-163-14-2	S21-751-163-12-2	S24-751-163-15-2	S28-751-163-21-2	S24-801-163-13-3	S28-801-163-19-6
	20	S21-751-203-11-2	S24-751-203-12-2	S24-751-203-12-2	S28-1001-203-18-2	S28-1001-203-18-2	S32-1001-203-22-2
	24	S24-751-243-13-3	S28-751-243-20-4	S28-1001-243-17-2	S28-1001-243-17-2	S32-1001-243-21-2	S32-802-243-18-3
10	2	S14-351-23-10-3	S16-351-23-12-4	S16-601-23-11-3	S16-621-23-11-2	S16-621-23-9-2	S16-621-23-9-2
	3	S14-351-33-9-4	S16-351-33-12-4	S16-621-33-10-2	S16-621-33-10-2	S16-621-33-9-3	S18-621-33-11-3
	4	S16-351-43-12-5	S16-601-43-10-5	S16-621-43-10-3	S16-621-43-8-3	S18-621-43-10-3	S21-621-43-13-4
	6	S16-351-63-11-6	S16-601-63-9-6	S18-621-63-11-4	S16-621-63-9-5	S21-621-63-12-6	S21-621-63-10-6
	8	S18-751-83-10-1	S21-751-83-13-1	S24-751-83-16-2	S21-801-83-11-2	S24-801-83-14-3	S24-801-83-11-3
	10	S21-751-103-15-2	S21-751-103-12-2	S24-751-103-15-2	S28-751-103-22-2	S28-751-103-22-2	S28-801-103-19-3
	12	S21-751-123-15-2	S21-751-123-12-2	S24-751-123-15-2	S28-751-123-22-2	S28-751-123-22-2	S28-801-123-19-5
	14	S21-751-143-11-2	S24-751-143-12-2	S24-751-143-12-2	S28-801-143-12-6	S28-801-143-12-6	S32-1001-143-22-2
20	S24-751-203-13-3	S28-751-203-20-4	S28-1001-203-17-2	S28-1001-203-17-2	S32-1001-203-21-2	S32-802-203-18-3	
8	2W	S16-351-27-11-5	S16-601-27-10-5	S16-621-27-10-3	S16-621-27-8-3	S18-621-27-10-3	S21-621-27-13-4
	3W	S16-351-37-11-6	S16-601-37-9-6	S18-621-37-11-4	S18-621-37-9-4	S21-621-37-12-6	S21-621-37-10-6
	3G	S16-751-47-11-1	S16-621-47-9-5	S18-621-47-11-6	S18-621-47-9-6	S21-801-47-12-2	S24-801-47-15-2
	4W	S16-751-47-9-1	S16-621-47-9-5	S18-621-47-11-6	S21-801-47-14-2	S21-801-47-11-2	S24-801-47-14-2
6	2W	S16-351-27-11-5	S16-601-27-9-5	S18-601-27-11-5	S18-621-27-9-3	S21-621-27-12-4	S21-621-27-10-4
	3W	S16-751-37-8-1	S16-621-37-8-4	S18-621-37-8-5	S18-621-37-8-5	S21-801-37-11-2	S24-801-37-14-2
	3G	S18-751-47-10-1	S21-751-47-13-2	S24-751-47-16-2	S21-801-47-9-2	S21-801-47-9-2	S24-801-47-12-3
	4W	S18-751-47-10-1	S21-751-47-13-2	S24-751-47-16-2	S21-801-47-11-2	S24-801-47-14-3	S24-801-47-11-3
4	2W	S18-751-212-10-1	S21-751-212-13-2	S24-751-212-16-2	S21-801-212-11-2	S24-801-212-14-3	S24-801-212-11-3
	3W	S18-751-312-10-2	S21-751-312-13-2	S24-751-312-16-2	S21-801-312-11-3	S24-801-312-14-3	S24-801-312-11-3
	3G	S21-751-412-14-2	S21-751-412-12-2	S24-751-412-15-2	S28-751-412-19-2	S24-801-412-13-4	S24-801-412-10-4
	4W	S21-751-412-14-2	S21-751-412-12-2	S24-751-412-15-2	S28-751-412-21-2	S24-801-412-13-3	S28-801-412-18-6
2	2W	S21-751-212-11-2	S24-751-212-12-2	S24-751-212-12-2	S28-751-212-18-2	S28-801-212-18-6	S28-801-212-18-6
	3W	S21-751-312-14-2	S21-751-312-12-2	S24-751-312-15-2	S28-751-312-19-2	S28-801-312-18-6	S28-801-312-18-6
	3G	S21-751-412-11-2	S24-751-412-11-3	S28-751-412-21-4	S28-1001-412-18-2	S28-1001-412-18-2	S32-1001-412-22-2
	4W	S21-751-412-11-2	S24-751-412-11-2	S28-751-412-21-4	S28-1001-412-18-2	S28-1001-412-18-2	S32-1001-412-22-2
1	2W	S21-751-220-11-2	S24-751-220-11-2	S28-751-220-20-2	S28-801-220-16-6	S28-801-220-16-6	S28-801-220-13-6
	3W	S24-751-320-13-3	S28-751-320-20-4	S28-1001-320-17-2	S28-1001-320-17-2	S32-1001-320-21-2	S32-1001-320-19-2
	3G	S24-751-420-13-5	S28-751-420-20-6	S28-1001-420-17-2	S28-1001-420-17-2	S32-1001-420-21-3	S32-1001-420-18-2
1/0	2W	S24-751-220-13-2	S28-751-220-20-3	S28-751-220-16-3	S28-1001-220-17-2	S32-1001-220-21-2	S32-802-220-18-3

Retrieve Reels Continued

COMPLETE DIMENSIONAL DATA is available on the following pages. Refer to the first three digits of the model number.

* TRAVELS GREATER THAN 200 FEET ARE POSSIBLE for those wire sizes with a ✓ next to them. Consult factory for additional reel models.

FEET OF ACTIVE TRAVEL						No. of Cond.	WIRE SIZE (AWG)	
100	120	140	160	180	200*			
S18-621-23-14-2	S21-621-23-17-2	S24-621-23-20-2	S28-621-23-24-3	S28-623-23-24-1	S21-801-23-16-E-3	2✓	16	
S18-621-33-14-2	S21-621-33-17-2	S24-621-33-20-3	S28-621-33-24-3	S28-623-33-24-1	S21-801-33-16-E-3	3✓		
S18-621-43-14-2	S21-621-43-17-3	S24-621-43-20-3	S28-621-43-24-4	S28-624-43-24-1	S24-801-43-19-D-4	4✓		
S21-621-63-16-3	S24-621-63-19-4	S28-621-63-24-6	S32-801-63-28-2	S24-801-63-16-C-3	S28-1001-63-23-F-4	6✓		
S21-621-83-14-4	S24-621-83-17-5	S32-801-83-28-2	S28-622-83-22-3	S24-1001-83-14-F-2	S24-802-83-12-F-6	8✓		
S21-621-103-14-6	S28-801-103-21-2	S32-801-103-25-3	S28-1001-103-20-E-2	S24-802-103-10-E-3	S28-802-103-20-C-3	10✓		
S24-801-123-16-2	S32-801-123-27-3	S32-801-123-25-3	S24-1001-123-13-F-3	S28-802-123-20-B-2	S28-802-123-20-C-3	12✓		
S24-801-143-16-2	S28-801-143-21-3	S32-801-143-25-3	S24-802-143-10-D-3	S28-802-143-19-C-4	S28-802-143-19-C-4	14✓		
S28-801-163-21-3	S28-801-163-21-3	S32-801-163-25-3	S28-802-163-19-B-3	S28-802-163-19-C-5	S28-1002-163-17-F-2	16✓		
S28-801-203-21-4	S32-801-203-25-5	S32-802-203-25-2	S28-802-203-16-C-6	S28-1002-203-16-F-3	S28-803-203-14-D-3	20✓		
S28-801-243-20-6	S28-802-243-18-2	S32-803-243-22-2	S28-1002-243-12-F-3	S28-804-243-10-D-3	S32-804-243-16-P-3	24✓		
S28-802-303-17-3	S32-802-303-21-3	S28-1002-303-14-E-2	S28-803-303-12-C-4	S28-804-303-10-D-3	S32-804-303-16-P-5	30✓		
S28-802-363-19-3	S32-802-363-20-3	S28-1002-363-13-F-5	S32-803-363-17-M-4	S32-804-363-14-N-3	S32-1004-363-12-Y-5	36✓		
S21-621-23-16-2	S24-621-23-19-3	S24-621-23-19-3	S28-621-23-24-4	S21-801-23-14-E-3	S24-801-23-17-D-3	2✓		14
S21-621-33-16-3	S21-621-33-16-3	S24-621-33-19-3	S28-622-33-24-2	S21-801-33-13-E-4	S24-1001-33-15-G-4	3✓		
S21-621-43-16-3	S24-621-43-19-4	S28-621-43-22-5	S32-801-43-28-2	S24-801-43-16-C-3	S21-802-43-10-F-3	4✓		
S21-621-63-13-4	S28-801-63-22-2	S32-801-63-26-3	S28-622-63-22-3	S24-802-63-13-D-3	S21-802-63-20-C-3	6✓		
S24-801-83-16-2	S28-801-83-21-2	S32-801-83-25-3	S28-1001-83-18-E-2	S24-802-83-9-E-3	S28-802-83-19-C-3	8✓		
S28-801-103-21-3	S28-801-103-21-3	S32-801-103-25-3	S28-802-103-16-C-3	S28-802-103-16-C-3	S28-1002-103-14-G-5	10✓		
S28-801-123-21-3	S28-801-123-21-3	S32-801-123-25-3	S28-802-123-16-C-4	S28-802-123-16-C-4	S28-803-123-14-D-3	12✓		
S28-801-143-20-3	S28-801-143-20-3	S32-802-143-24-2	S28-802-143-15-C-6	S28-1002-143-12-F-2	S28-804-143-10-E-3	14✓		
S28-801-163-20-4	S32-802-163-24-2	S32-804-163-21-1	S28-1002-163-12-F-3	S28-804-163-10-D-3	S32-804-163-16-P-3	16✓		
S28-802-203-19-2	S32-802-203-20-3	S28-1002-203-13-E-2	S32-1002-203-16-Q-2	S32-804-203-14-N-3	S32-1004-203-12-Y-4	20✓		
S28-802-243-15-3	S32-802-243-19-3	S32-1002-243-16-P-2				24		
S32-802-303-18-3	S32-1002-303-15-N-2					30		
S21-621-23-16-3	S24-621-23-19-3	S28-621-23-22-4	S32-801-23-28-2	S24-801-23-16-C-3	S24-1001-23-14-G-4	2✓	12	
S21-621-33-16-3	S24-621-33-19-4	S28-621-33-22-5	S32-801-33-28-2	S24-801-33-16-C-3	S28-1001-33-22-F-4	3✓		
S21-621-43-14-3	S24-621-43-17-4	S28-621-43-22-6	S28-622-43-22-3	S28-1001-43-22-E-2	S24-802-43-12-F-6	4✓		
S24-621-63-16-6	S28-801-63-21-2	S32-801-63-25-3	S28-1001-63-19-E-2	S28-802-63-19-B-2	S28-802-63-17-C-3	6✓		
S28-801-83-21-3	S28-801-83-21-3	S32-801-83-25-3	S28-802-83-16-C-3	S28-802-83-16-C-3	S28-1002-83-14-G-5	8✓		
S28-801-103-20-3	S32-801-103-24-4	S32-802-103-22-2	S28-802-103-12-C-4	S28-803-103-10-D-3	S32-803-103-16-P-4	10✓		
S28-801-123-20-3	S32-801-123-24-5	S32-804-123-21-1	S28-1002-123-12-F-3	S28-803-123-10-D-3	S32-803-123-16-P-5	12✓		
S28-801-143-17-4	S32-802-143-21-2	S32-804-143-21-1	S28-1002-143-11-F-3	S28-804-143-9-D-3	S32-804-143-13-P-3	14✓		
S28-801-163-19-6	S32-802-163-20-3	S28-1002-163-13-E-2	S32-1002-163-16-Q-2	S32-804-163-14-N-3	S32-804-163-11-P-3	16✓		
S28-802-203-15-3	S32-802-203-19-3	S32-1002-203-16-P-2				20		
S32-802-243-15-3	S32-1002-243-12-P-2					24		
S21-621-23-14-3	S24-621-23-17-3	S28-621-23-22-5	S28-622-23-22-2	S28-801-23-22-B-3	S24-802-23-13-E-3	2✓		10
S21-621-33-14-3	S24-621-33-17-4	S28-621-33-22-6	S28-622-33-22-3	S28-1001-33-22-E-2	S24-802-33-12-E-3	3✓		
S24-621-43-16-5	S28-801-43-21-2	S32-801-43-25-3	S24-1001-43-13-F-3	S28-802-43-20-B-2	S28-802-43-20-C-3	4✓		
S28-801-63-21-3	S28-801-63-21-3	S32-801-63-25-3	S28-802-63-16-B-2	S28-802-63-16-C-3	S28-1002-63-14-G-5	6✓		
S28-801-83-20-3	S32-801-83-24-4	S32-804-83-21-1	S28-802-83-11-C-4	S28-803-83-10-D-3	S32-803-83-16-P-5	8✓		
S28-801-103-19-3	S28-622-103-16-6	S32-804-103-21-1	S28-1002-103-11-F-3	S32-1002-103-18-Q-2	S32-804-103-15-P-3	10✓		
S28-801-123-19-5	S32-802-123-20-2	S32-804-123-20-1	S32-1002-123-16-Q-2	S32-804-123-14-N-3	S32-804-123-12-P-3	12✓		
S28-802-143-15-3	S32-802-143-19-3	S32-1002-143-16-P-2				14		
S32-802-203-15-3	S32-1002-203-12-P-3					20		
S24-621-27-16-5	S28-621-27-18-6	S32-801-27-26-3	S32-803-27-26-1	S28-802-27-19-B-2	S28-802-27-17-C-3	2W✓	8	
S28-801-37-21-3	S28-801-37-21-3	S32-801-37-25-3	S28-802-37-16-B-2	S28-802-37-16-C-3	S28-1002-37-14-G-5	3W✓		
S28-801-47-21-3	S28-801-47-21-3	S32-802-47-25-2	S28-802-47-16-C-5	S28-1002-47-16-F-3	S28-803-47-14-D-3	3G✓		
S28-801-47-20-3	S28-801-47-20-3	S32-801-47-24-3	S28-802-47-15-C-5	S28-1002-47-13-F-2	S28-803-47-13-D-3	4W✓		
S24-621-27-13-6	S28-801-27-21-2	S32-801-27-25-3	S28-1001-27-18-E-2	S28-802-27-16-C-3	S28-802-27-16-D-4	2W✓	6	
S28-801-37-20-3	S28-801-37-20-3	S32-801-37-24-3	S28-802-37-15-C-5	S28-1002-37-13-F-2	S28-803-37-13-D-3	3W✓		
S28-801-47-20-3	S32-801-47-24-6	S32-802-47-22-2	S28-1002-47-13-F-3	S28-803-47-11-D-4	S32-803-47-17-N-3	3G✓		
S28-801-47-17-3	S28-622-47-17-6	S32-804-47-21-1	S28-1002-47-12-F-3	S28-804-47-10-D-3	S32-804-47-16-P-3	4W✓		
S28-801-212-17-3	S28-622-212-17-6	S32-804-212-21-1	S28-1002-212-12-F-3	S32-803-212-16-N-3	S32-803-212-16-N-3	2W✓	4	
S28-801-312-17-3	S28-622-312-17-6	S32-804-312-21-1	S28-1002-312-12-F-3	S28-804-312-10-D-3	S32-804-312-16-P-3	3W✓		
S28-802-412-16-2	S32-802-412-20-3	S32-1002-412-17-P-2	S32-803-412-15-M-3	S32-804-412-12-N-3		3G		
S28-802-412-19-2	S32-802-412-20-3	S28-1002-412-13-E-2	S32-1002-412-17-Q-3	S32-804-412-14-N-3	S32-1004-412-12-Y-5	4W✓		
S28-802-212-15-2	S32-802-212-19-3	S32-1002-212-16-P-2	S32-804-212-11-N-3			2W	2	
S28-802-312-16-2	S32-802-312-20-3	S32-1002-312-17-P-2	S32-803-312-14-M-3			3W		
S28-802-412-15-3	S32-802-412-19-3	S32-804-412-12-M-3				3G		
S28-802-412-15-3	S32-802-412-19-3	S32-1002-412-16-P-3				4W		
S32-802-220-18-3	S32-1002-220-15-N-2	S32-1002-220-12-Q-3				2W	1	
S32-802-320-15-3	S32-1002-320-12-P-3					3W		
S32-803-420-14-3						3G		
S32-802-220-15-3	S32-1002-220-12-P-2					2W	1/0	

Optional Accessories

ROLLER CABLE GUIDES

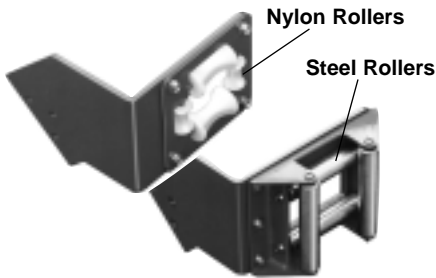

Horizontal/Vertical Up* Cable Guides

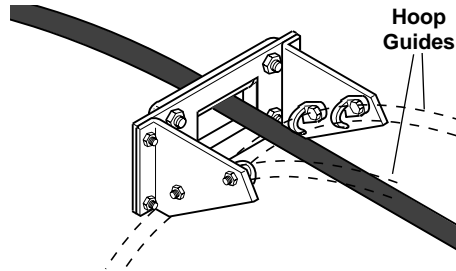

Hoop mounted Cable Guide-Steel or Nylon Rollers

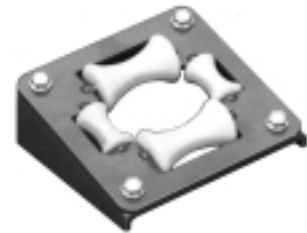

Vertical Down Cable Guide-Steel or Nylon Rollers

REEL MODEL	PART NUMBER	WINDOW OPENING (inches)
------------	-------------	-------------------------

Frame Mounted Horizontal/Vertical Up*-Nylon Rollers**		
S14	012079	3.18 x 2.38
S16, S18, S21	012082	3.00 x 2.13
S24	012085	3.00 x 2.13
S28	012087	4.63 x 2.63
S32	04045401	4.63 x 2.63

Frame Mounted Horizontal/Vertical Up*-Steel Rollers**		
S16, S18, S21	035220	3.00 x 2.25
S24	035221	3.00 x 2.25
S28	035222	3.00 x 2.25
S32	N/A	N/A

Frame Mounted Vertical Down*-Nylon Rollers***		
S14, S16, S18	012084	3.18 x 2.38
S21, S24	012084	3.18 x 2.38
S28	012089	4.63 x 2.63
S32	040457	4.63 x 2.63

Frame Mounted Vertical Down*-Steel Rollers***		
S16, S18	035226	2.25 x 3.00
S21, S24	035226	2.25 x 3.00
S28	035227	2.25 x 3.00
S32	N/A	N/A

REEL MODEL	PART NUMBER	WINDOW OPENING (inches)
------------	-------------	-------------------------

Hoop Mounted Horizontal/Vertical Up*-Nylon Rollers***		
S14, S16	N/A	N/A
S18, S21, S24	015607	3.18 x 2.38
S28, S32	015608	4.63 x 2.63

Hoop Mounted Horizontal/Vertical Up*-Steel Rollers		
S14, S16, S18	N/A	N/A
S21, S24	034742	2.25 x 3.00
S28, S32	034743	2.25 x 3.00

Hoop Mounted Vertical Down*-Nylon Rollers		
S14, S16	N/A	N/A
S18, S21, S24	015674	3.18 x 2.38
S28, S32	015608	4.50 x 2.62

Hoop Mounted Vertical Down*-Steel Rollers		
S14, S16, S18	N/A	N/A
S21, S24	034744	3.00 x 2.25
S28, S32	034745	5.00 x 2.25

Hoop Guide Assembly (Not pictured. See pages 19 – 28)		
S14, S16	N/A	NOT APPLICABLE
S18	012095	
S21	012096	
S24	012097	
S28	012098	
S32	039712	

* "Up" and "Down" assume reel mounted base down.
 ** Standard rotation. Consult factory for reverse rotation.
 *** Standard or reverse rotation.

340° PIVOT BASE



REEL MODEL	PART NUMBER
S14	012076
S16, S18, S21	012077
S24, S28, S32	012077

KELLEMS® CABLE GRIP



PART NUMBER	FITS O.D.s MIN - MAX
027614	0.41 - 0.52
027615	0.53 - 0.74
027616	0.75 - 0.99
027617	1.00 - 1.24
027618	1.25 - 1.49

CABLE STOPS

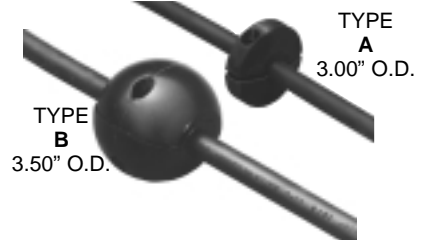

PART NUMBER	TYPE	FITS O.D.s MIN - MAX
037529	B	0.44 - 0.62
037531	A	0.62 - 0.75
037532	A	0.75 - 1.05
037533	A	1.06 - 1.30
037535	B	0.75 - 1.05
037536	B	1.06 - 1.38
037537	B	1.39 - 1.55

SPOOL LOCK all models....P/N 012091

DOG & RATCHET S14-S28.....P/N 012090 S32 only....P/N 039887

LIMIT SWITCH S14-S28.....P/N 012092 S32 only.....P/N 040449

S14 DIRECT DRIVE

Dimensional Data & Optional Accessories

DIMENSIONS

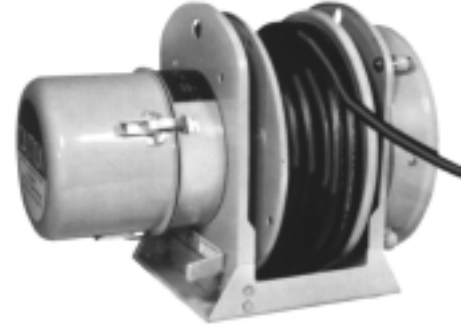
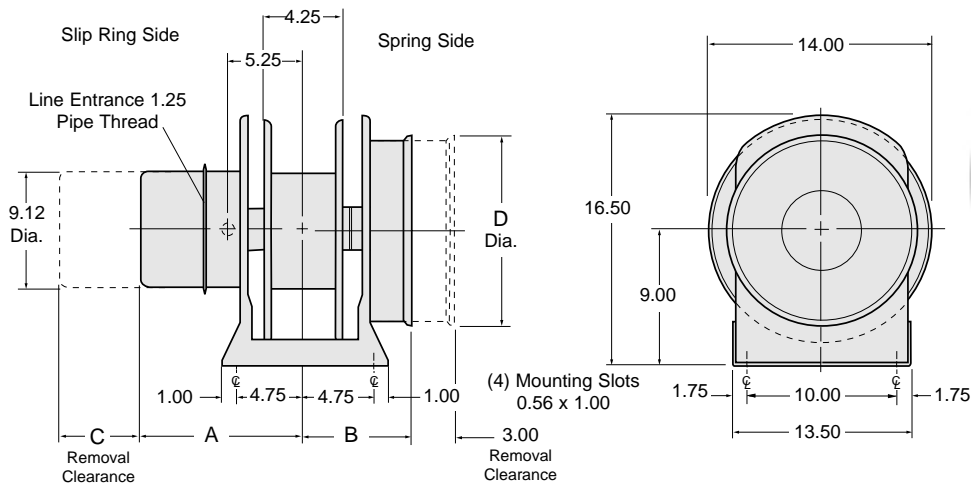

Cable payout, as pictured above, denotes standard rotation.

SLIP RING HOUSING DIMENSIONS

Second Series of Digits in Model Number	23	63
	33	83
	43	27
"A" Dimension in Inches	14.50	17.00
"C" Dimension in Inches	8.50	11.00

SPRING MOTOR DIMENSIONS

MODEL NUMBER	S14351	S14601	S14751
"B" Dimension in Inches	6.60	6.60	7.12
"D" Diameter in Inches	10.56	10.56	10.56
Approximate Net Weight of Reel with Spring Motor(s)	85 lbs.	90 lbs.	95 lbs.

OPTIONAL ACCESSORIES

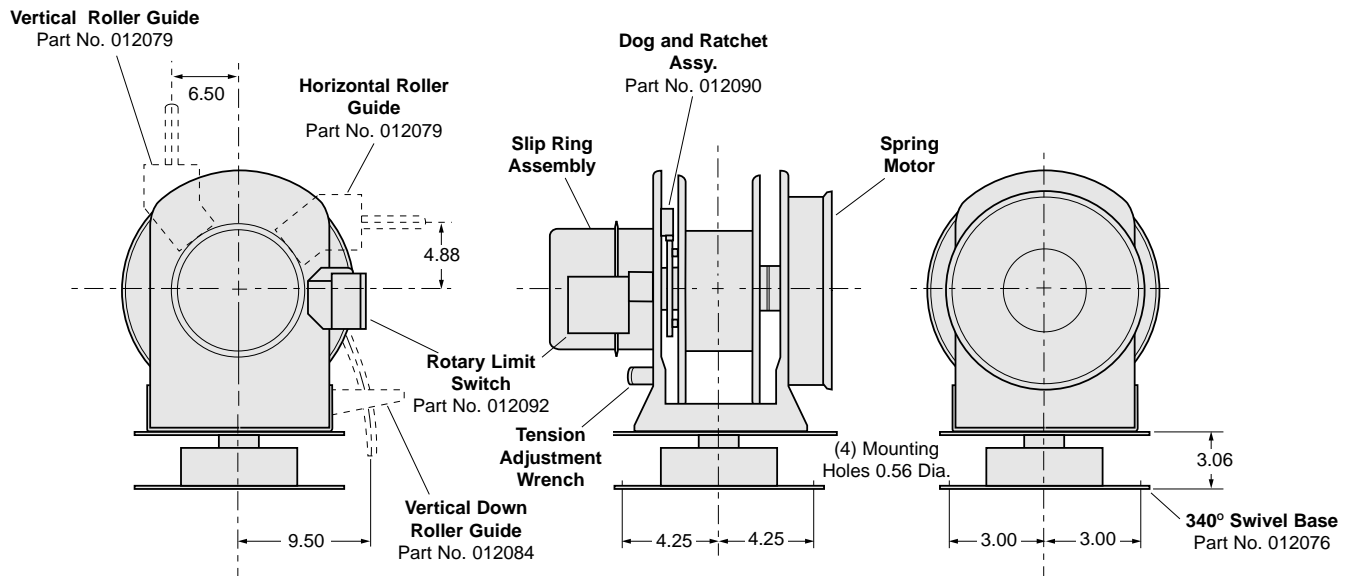

S16 DIRECT DRIVE

Dimensional Data & Optional Accessories

DIMENSIONS

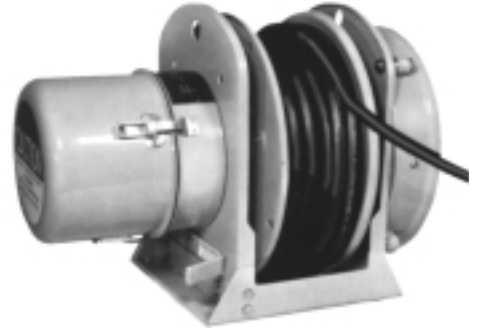
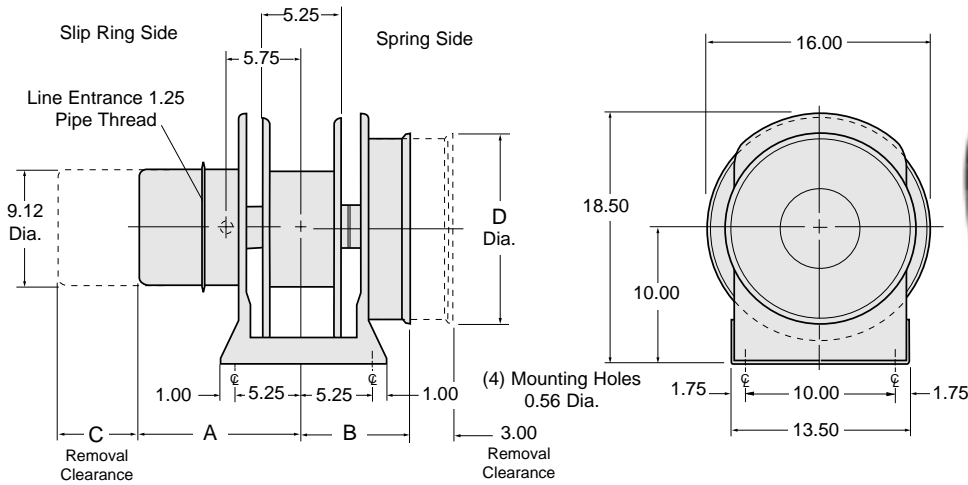

Cable payout, as pictured above, denotes standard rotation.

SLIP RING HOUSING DIMENSIONS

Second Series of Digits in Model Number	23	63	103	163	203
		33			
	43	27			
		37			
		47			
"A" Dimension in Inches	15.00	17.50	20.00	22.50	27.50
"C" Dimension in Inches	8.50	11.00	13.50	16.00	21.00

SPRING MOTOR DIMENSIONS

MODEL NUMBER	S16351	S16601	S1621	S16622	S16751	S16801
"B" Dimension in Inches	7.10	7.10	7.62	10.25	7.62	7.62
"D" Diameter in Inches	10.56	10.56	14.38	14.38	10.56	14.38
Approximate Net Weight of Reel with Spring Motor(s)	95 lbs.	100 lbs.	120 lbs.	170 lbs.	105 lbs.	135 lbs.

OPTIONAL ACCESSORIES

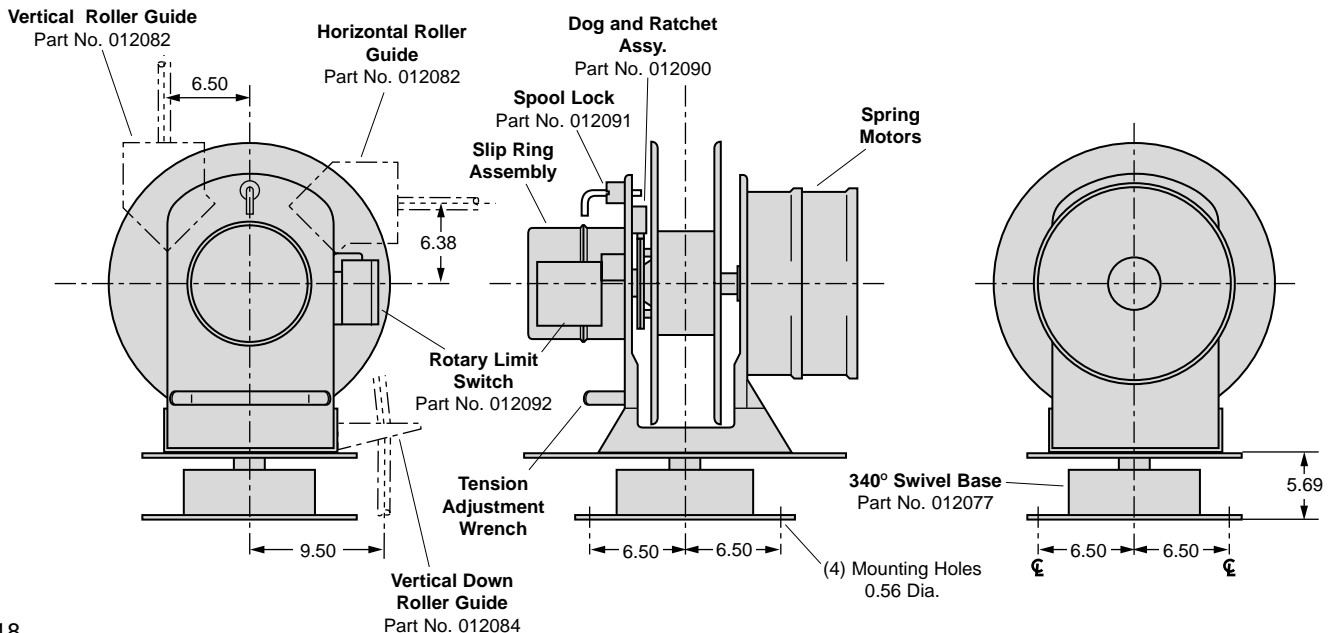

S18 DIRECT DRIVE

Dimensional Data & Optional Accessories

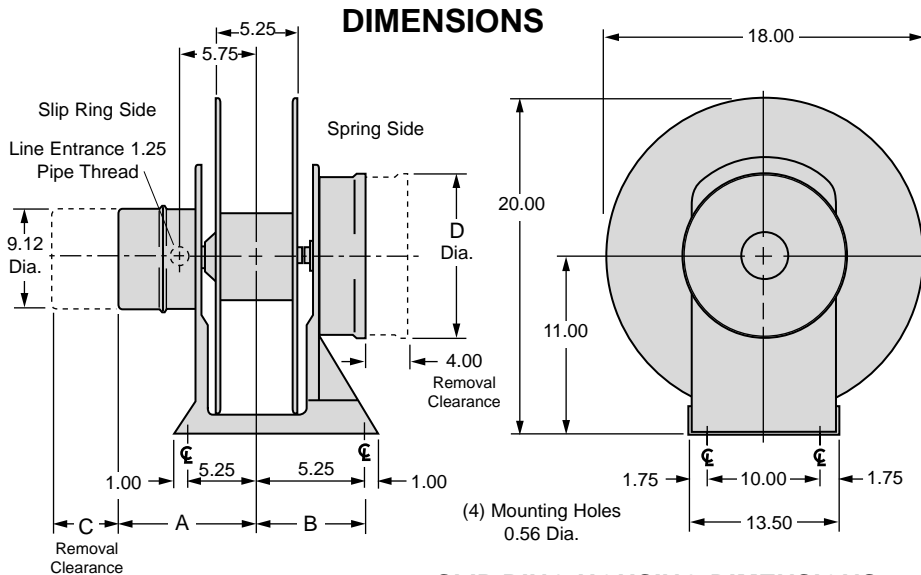

Cable payout, as pictured above, denotes reverse rotation.

SLIP RING HOUSING DIMENSIONS

Second Series of Digits in Model Number

23	63	37	103	143	203
33	83	47	123	163	243
43	27	212			

"A" Dimension-Inches

15.00	17.50	20.00	22.50	27.50
-------	-------	-------	-------	-------

"C" Dimension-Inches

8.50	11.00	13.50	16.00	21.00
------	-------	-------	-------	-------

SPRING MOTOR DIMENSIONS

MODEL NUMBER

S18621	S18622	S18751	S18801	S18802
--------	--------	--------	--------	--------

"B" Dimension in Inches

7.62	10.25	7.62	7.62	10.25
------	-------	------	------	-------

"D" Diameter in Inches

14.38	14.38	10.56	14.38	14.38
-------	-------	-------	-------	-------

Approximate Net Weight of Reel with Spring Motor(s)

130	180	115	145	200
-----	-----	-----	-----	-----

OPTIONAL ACCESSORIES

Vertical Roller Guide
Part No. 012082

If Hoop Guides are used, optional Roller Guides may be found on page 16.

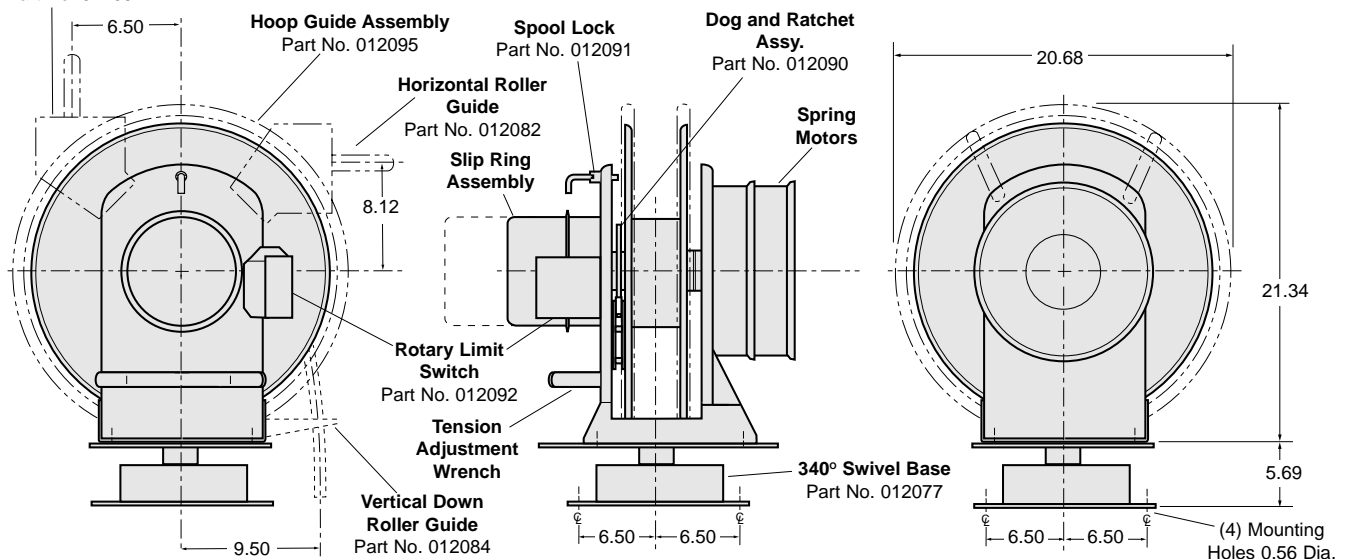

S21 DIRECT DRIVE

Dimensional Data & Optional Accessories

DIMENSIONS

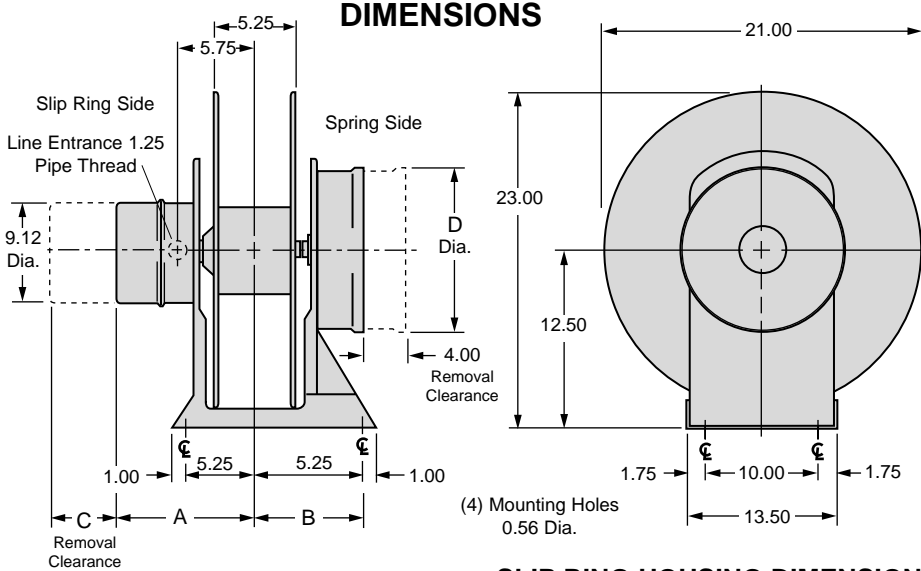

Cable payout, as pictured above, denotes reverse rotation.

SLIP RING HOUSING DIMENSIONS

Second Series of Digits in Model Number

23	63	37	103	143	203	303
33	83	47	123	163	243	363
43	27	212	312	412		
"A" Dimension-Inches	15.00	17.50	20.00	22.50	27.50	35.50
"C" Dimension-Inches	8.50	11.00	13.50	16.00	21.00	29.00

SPRING MOTOR DIMENSIONS CON'T

MODEL NUMBER	S21621	S21622	S21751	S21752	S21801	S21802	S211001
"B" Dimension in Inches	7.62	10.25	7.62	10.25	7.62	10.25	8.50
"D" Diameter in Inches	14.38	14.38	10.56	10.56	14.38	14.38	14.38
Approximate Net Weight of Reel with Spring Motor(s)	140	190	125	175	155	210	165

OPTIONAL ACCESSORIES

Vertical Roller Guide
Part No. 012082

If Hoop Guides are used, optional Roller Guides may be found on page 16.

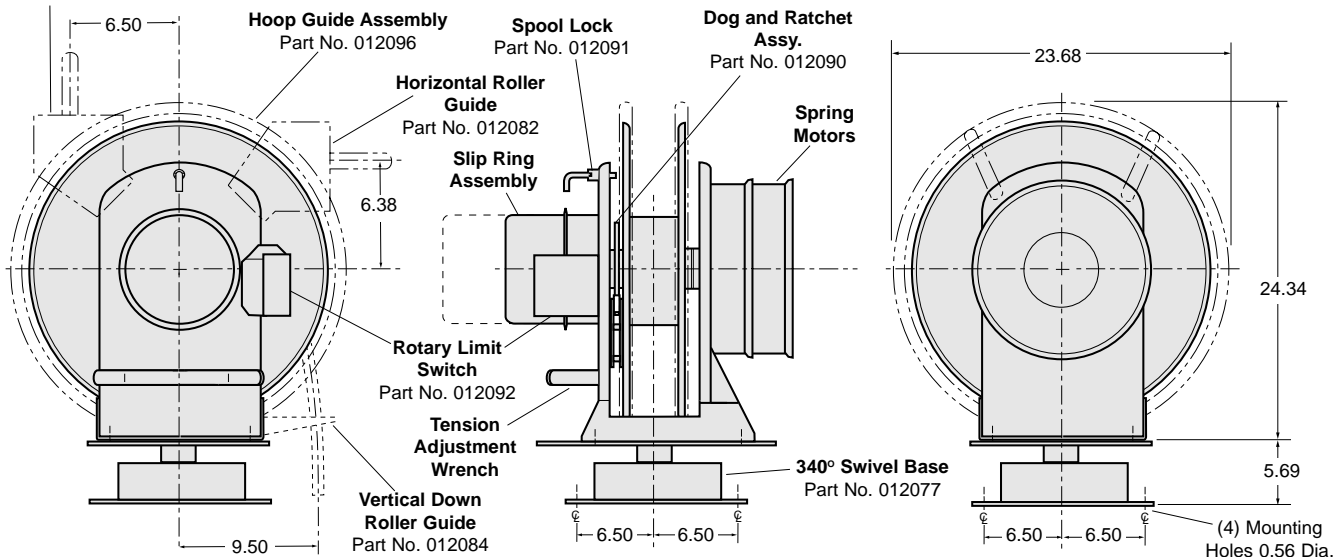

S21

GEARED DRIVE

Dimensional Data & Optional Accessories

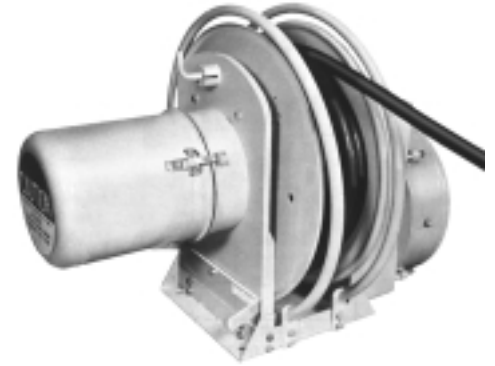
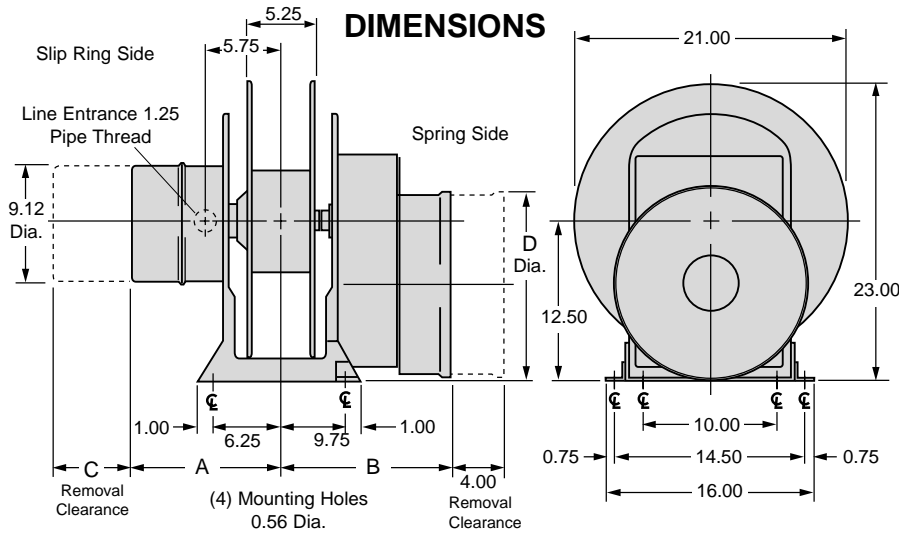

Cable payout, as pictured above, denotes standard rotation.

NOTE: Above illustration includes some of the optional accessories described below.

SLIP RING HOUSING DIMENSIONS

Second Series of Digits in Model Number	23	63
	33	83
	43	
"A" Dimension in Inches	15.00	17.50
"C" Dimension in Inches	8.50	11.00

SPRING MOTOR DIMENSIONS

MODEL NUMBER	S21801	S21802	S21803	S21804	S211001	S211002
"B" Dimension in Inches	12.62	15.25	17.88	20.50	13.50	16.88
"D" Diameter in Inches	14.38	14.38	14.38	14.38	14.38	14.38
Approximate Net Weight of Reel with Spring Motor(s)	180 lbs.	235 lbs.	290 lbs.	345 lbs.	190 lbs.	250 lbs.

OPTIONAL ACCESSORIES

Vertical Roller Guide
Part No. 012082

If Hoop Guides are used, optional Roller Guides may be found on page 16.

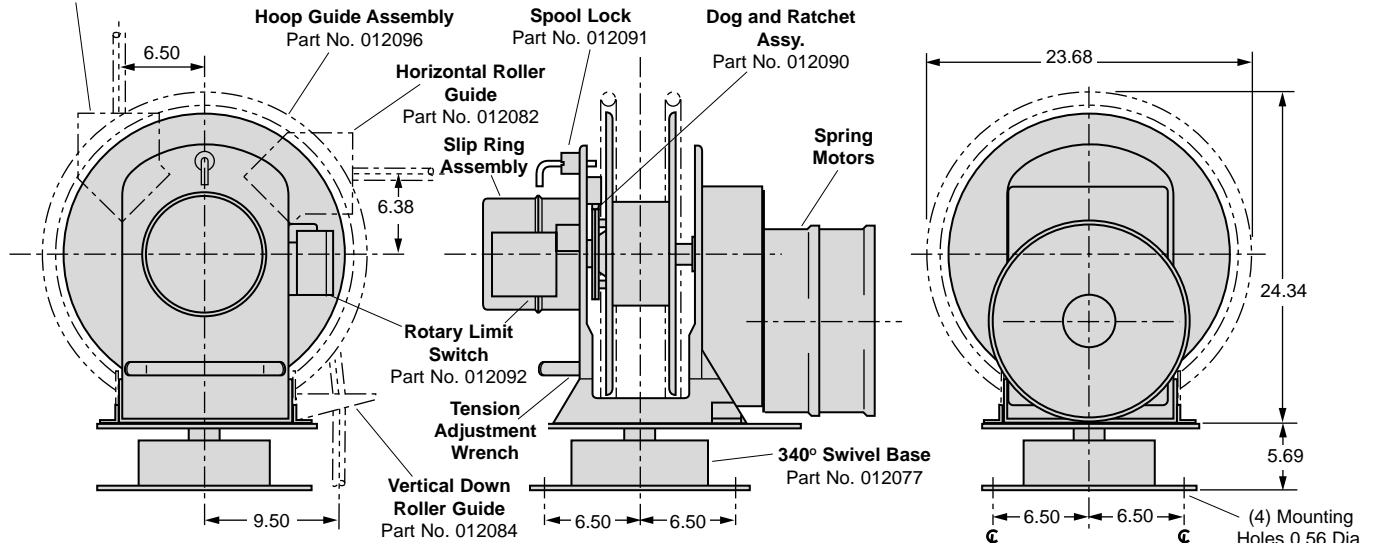

S24 DIRECT DRIVE

Dimensional Data & Optional Accessories

DIMENSIONS

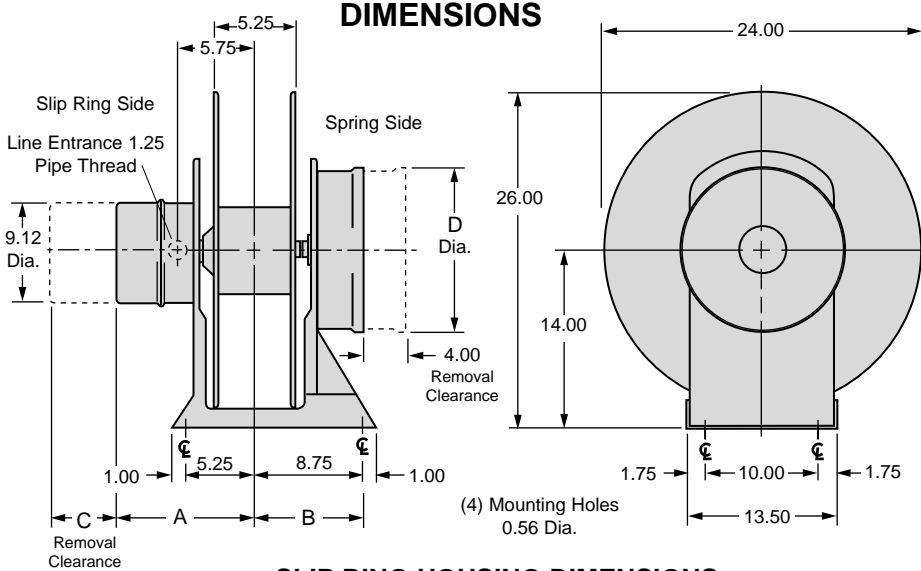

Cable payout, as pictured above, denotes reverse rotation.

SLIP RING HOUSING DIMENSIONS

Second Series of Digits in Model Number

23	63	212	103	143	203	303
33	83	220	123	163	243	363
43	27	320	312	412		
	37	420				
	47					
"A" Dimension-Inches	15.00	17.50	20.00	22.50	27.50	35.50
"C" Dimension-Inches	8.50	11.00	13.50	16.00	21.00	29.00

SPRING MOTOR DIMENSIONS CON'T

MODEL NUMBER	S24621	S24622	S24623	S24624	S24751	S24752	S24753	S24801	S24802	S24803	S24804	S241001	S241002
"B" Dimension in Inches	7.62	10.25	12.88	15.50	7.62	10.25	12.88	7.62	10.25	12.88	15.50	8.50	11.88
"D" Diameter in Inches	14.38	14.38	14.38	14.38	10.56	10.56	10.56	14.38	14.38	14.38	14.38	14.38	14.38
Approximate Net Weight of Reel with Spring Motor(s)	150	200	250	300	135	185	235	165	220	275	330	175	235

OPTIONAL ACCESSORIES

Vertical Roller Guide
Part No. 012085

If Hoop Guides are used, optional Roller Guides may be found on page 16.

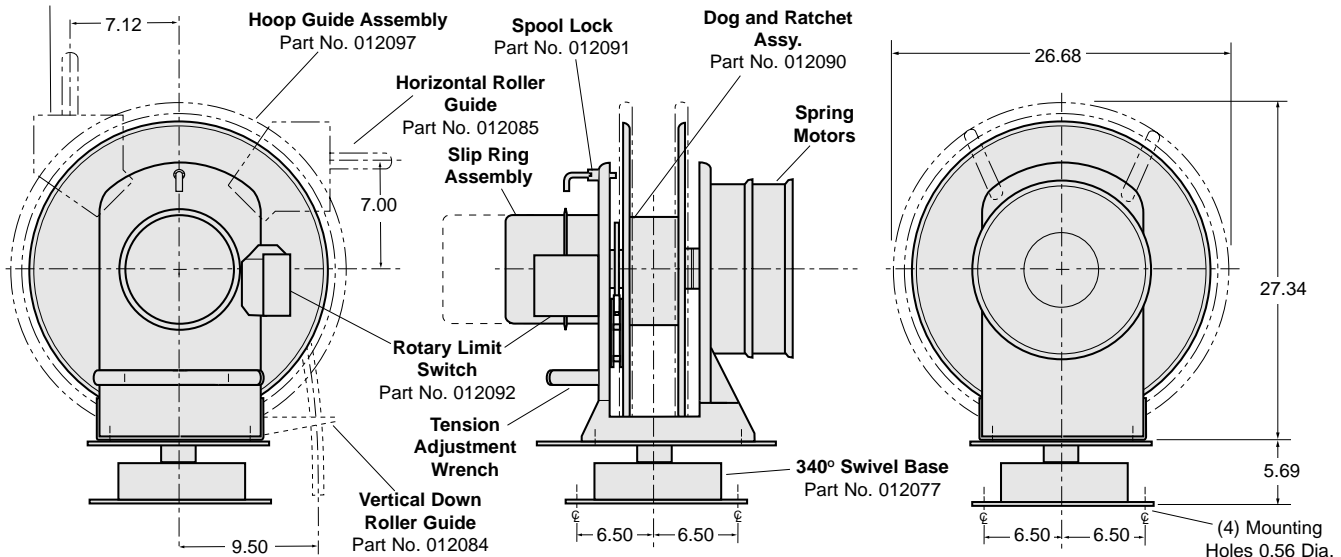

S24

GEARED DRIVE

Dimensional Data & Optional Accessories

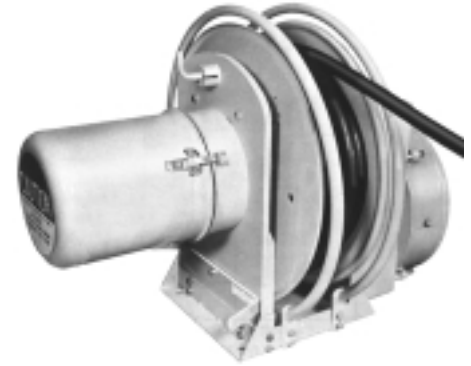
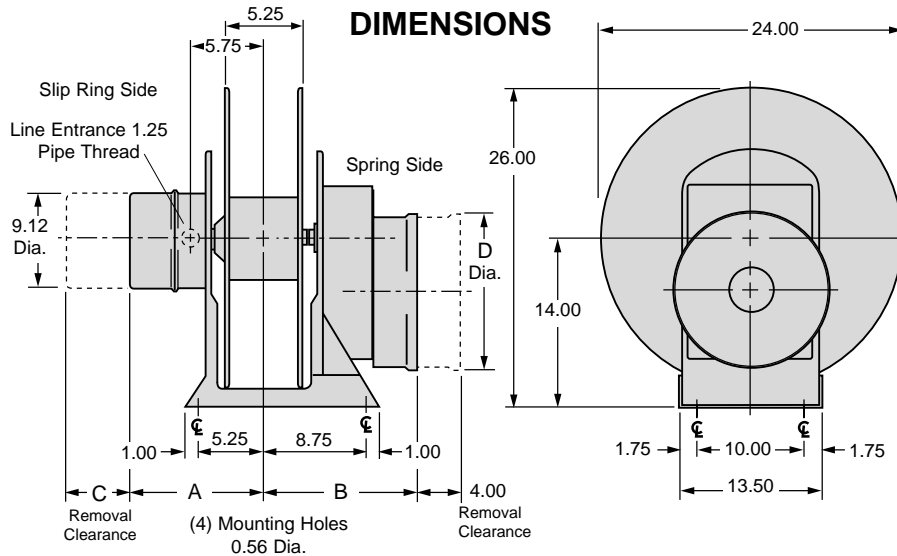

Cable payout, as pictured above, denotes standard rotation.

NOTE: Above illustration includes some of the optional accessories described below.

SLIP RING HOUSING DIMENSIONS

Second Series of Digits in Model Number

23	63	103	163	
33	83	123		
43	27	37		
	47			
"A" Dimension in Inches	15.00	17.50	20.00	22.50
"C" Dimension in Inches	8.50	11.00	13.50	16.00

SPRING MOTOR DIMENSIONS

MODEL NUMBER	S24801	S24802	S24803	S24804	S241001	S241002
"B" Dimension in Inches	12.62	15.25	17.88	20.50	13.50	16.88
"D Diameter in Inches	14.38	14.38	14.38	14.38	14.38	14.38
Approximate Net Weight of Reel with Spring Motor(s)	190 lbs.	245 lbs.	300 lbs.	355 lbs.	200 lbs.	260 lbs.

OPTIONAL ACCESSORIES

Vertical Roller Guide
Part No. 012085

If Hoop Guides are used, optional Roller Guides may be found on page 16.

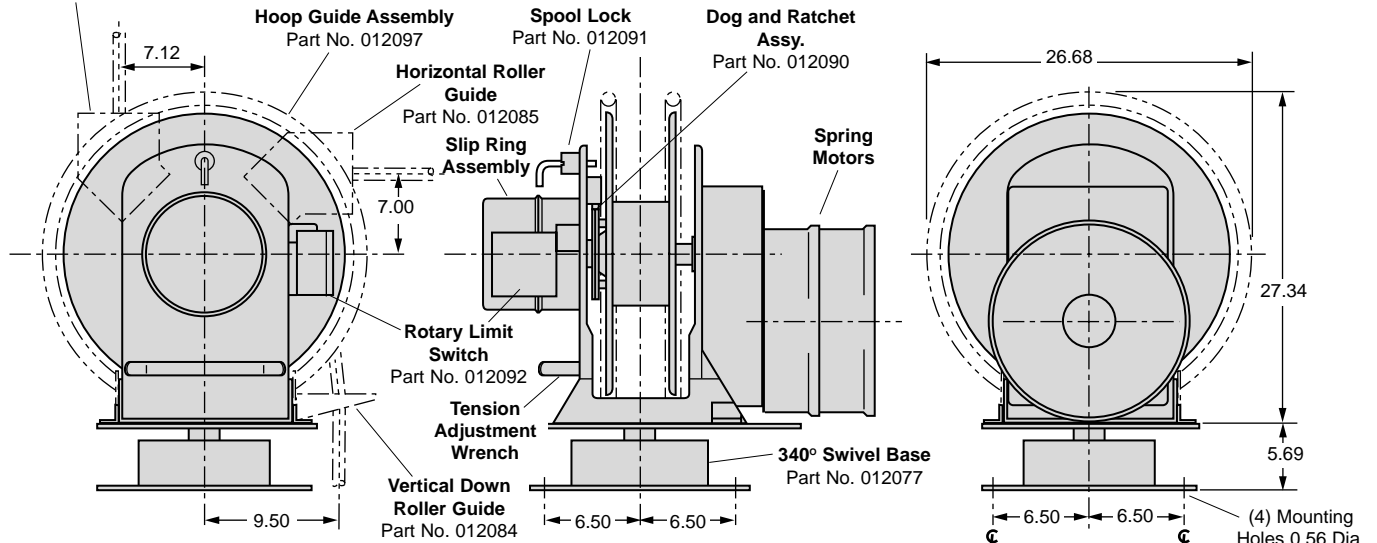

S28 DIRECT DRIVE

Dimensional Data & Optional Accessories

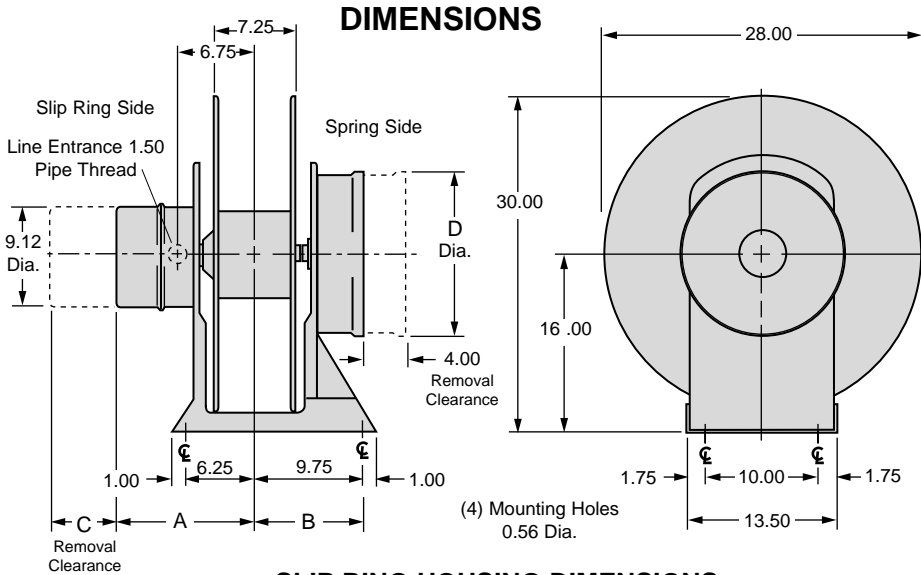

Cable payout, as pictured above, denotes reverse rotation.

SLIP RING HOUSING DIMENSIONS

Second Series of Digits in Model Number

23	63	212	103	143	203	303
33	83	220	123	163	243	363
43	27	320	312	412		
	37	420				
	47					
"A" Dimension-Inches	16.00	18.50	21.00	23.50	28.50	36.50
"C" Dimension-Inches	8.50	11.00	13.50	16.00	21.00	29.00

SPRING MOTOR DIMENSIONS

MODEL NUMBER	S28621	S28622	S28623
"B" Dimension-inches	8.62	11.25	13.88
"D" Diameter-inches	14.38	14.38	14.38
Approx. Net Weight-lbs.*	165	215	265

SPRING MOTOR DIMENSIONS CON'T

MODEL NUMBER	S28624	S28751	S28752	S28753	S28754	S28801	S28802	S28803	S28804	S281001	S281002	S281003	S281004
"B" Dimension-inches	16.50	8.62	11.25	13.88	16.50	8.62	11.25	13.88	16.50	9.50	12.88	16.25	19.62
"D" Diameter-inches	14.38	10.56	10.56	10.56	10.56	14.38	14.38	14.38	14.38	14.38	14.38	14.38	14.38
Approx. Net Weight-lbs.*	315	150	200	250	300	180	235	290	345	190	250	310	370

* Approximate Net Weight of Reel with Spring Motor(s) Designated

OPTIONAL ACCESSORIES

Vertical Roller Guide
Part No. 012087

If Hoop Guides are used, optional Roller Guides may be found on page 16.

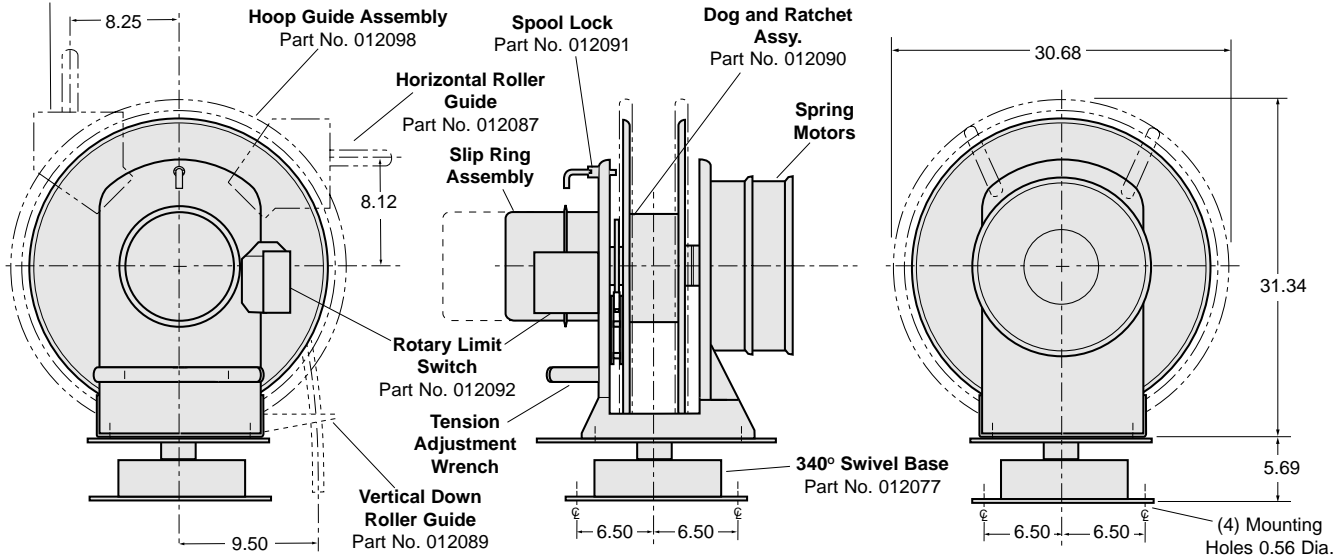

S28

GEARED DRIVE

Dimensional Data & Optional Accessories

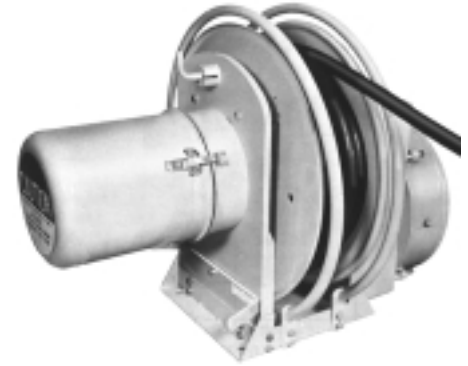
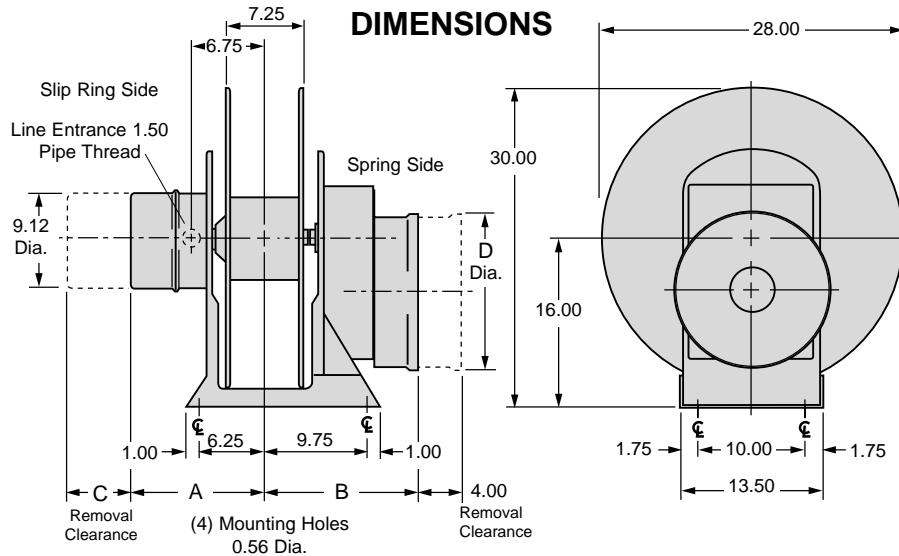

Cable payout, as pictured above, denotes standard rotation.

NOTE: Above illustration includes some of the optional accessories described below.

SLIP RING HOUSING DIMENSIONS

Second Series of Digits in Model Number

23	63	212	103	143	203	303
33	83	220	123	163	243	363
43	27	312	412			
	37					
	47					
"A" Dimension in Inches	16.00	18.50	21.00	23.50	28.50	36.50
"C" Dimension in Inches	8.50	11.00	13.50	16.00	21.00	29.00

SPRING MOTOR DIMENSIONS

MODEL NUMBER

"B" Dimension in Inches

"D" Diameter in Inches

Approximate Net Weight of Reel with Spring Motor(s)

S28801	S28802	S28803	S28804	S281001	S281002	S281003	S281004
13.62	16.25	18.88	21.50	14.50	17.88	21.25	24.62
14.38	14.38	14.38	14.38	14.38	14.38	14.38	14.38
205 lbs.	260 lbs.	315 lbs.	370 lbs.	215 lbs.	275 lbs.	335 lbs.	395 lbs.

OPTIONAL ACCESSORIES

Vertical Roller Guide
Part No. 012087

If Hoop Guides are used, optional Roller Guides may be found on page 16.

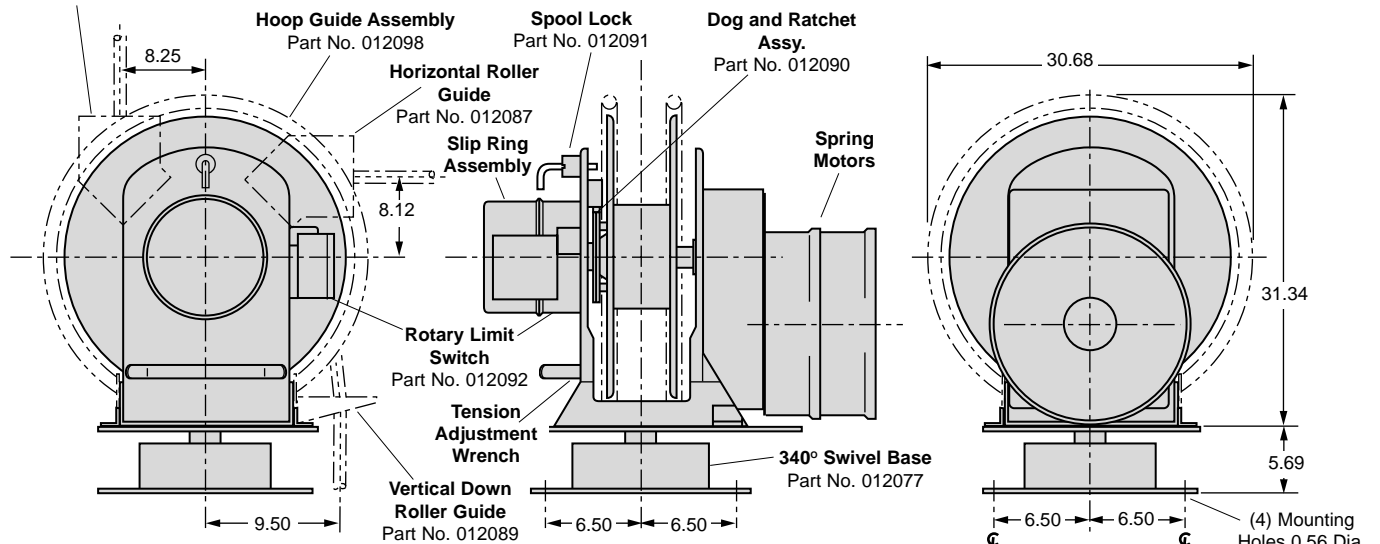

S32 DIRECT DRIVE

Dimensional Data & Optional Accessories

DIMENSIONS

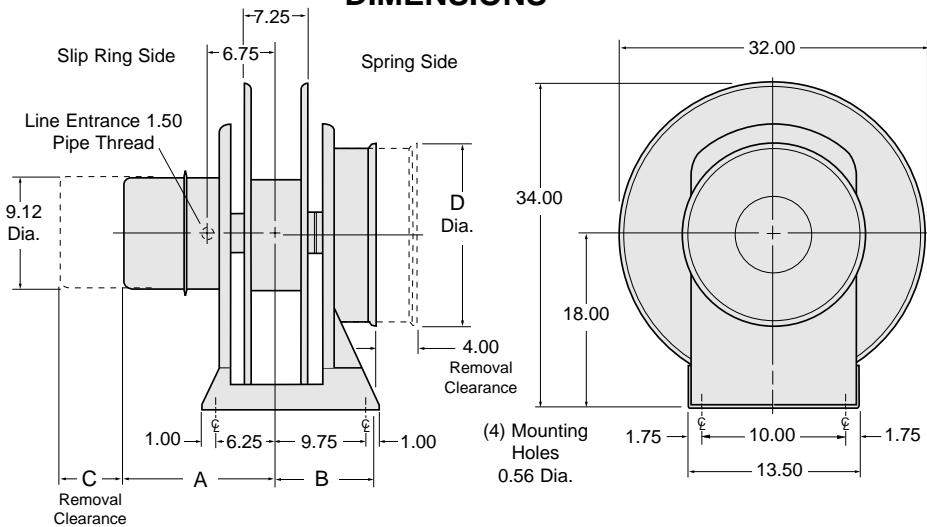

Cable payout, as pictured above, denotes standard rotation.

NOTE: Above illustration includes some of the optional accessories described below.

SLIP RING HOUSING DIMENSIONS

Second Series of Digits in Model Number

23	63	212	103	143	203	303
33	83	220	123	163	243	363
43	27	320	312	412		
	37	420				
	47					
"A" Dimension in Inches	16.00	18.50	21.00	23.50	28.50	36.50
"C" Dimension in Inches	8.50	11.00	13.50	16.00	21.00	29.00

SPRING MOTOR DIMENSIONS

MODEL NUMBER

"B" Dimension in Inches

"D" Diameter in Inches

Approximate Net Weight of Reel with Spring Motor(s)

MODEL NUMBER	S32801	S32802	S32803	S32804	S321001	S321002	S321003	S321004
"B" Dimension in Inches	8.62	11.25	13.88	16.50	9.50	12.88	16.25	19.62
"D" Diameter in Inches	14.38	14.38	14.38	14.38	14.38	14.38	14.38	14.38
Approximate Net Weight of Reel with Spring Motor(s)	200 lbs.	260 lbs.	320 lbs.	380 lbs.	210 lbs.	275 lbs.	340 lbs.	410 lbs.

OPTIONAL ACCESSORIES

Vertical Roller Guide
Part No. 04045401

If Hoop Guides are used, optional Roller Guides may be found on page 16.

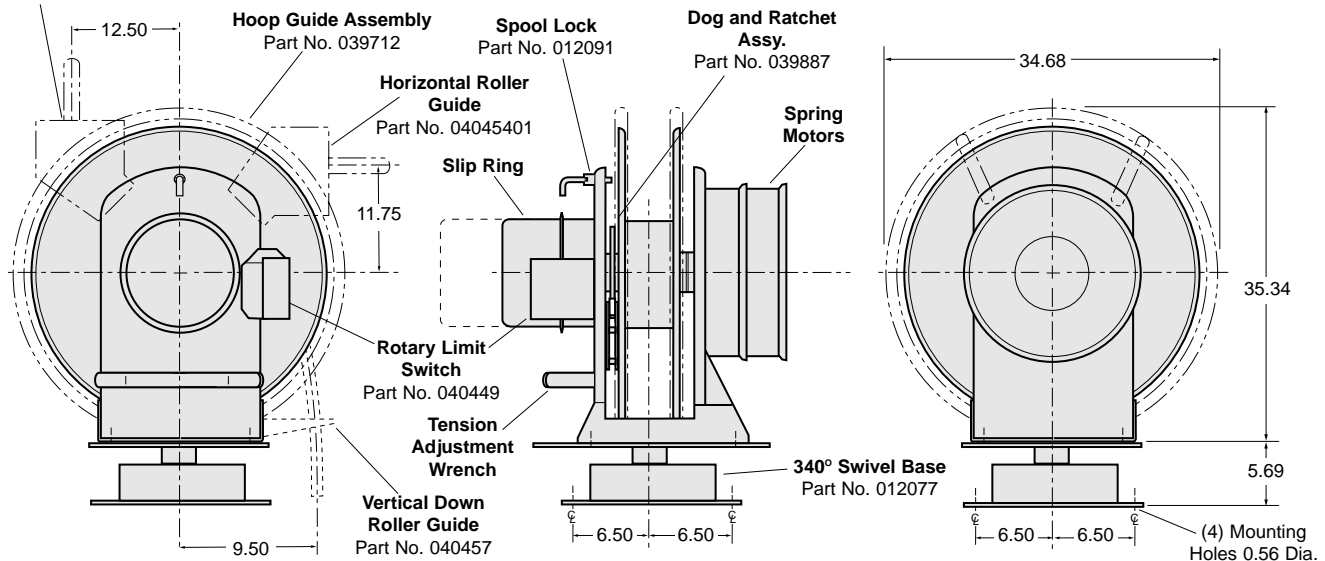

S32

GEARED DRIVE

Dimensional Data & Optional Accessories

DIMENSIONS

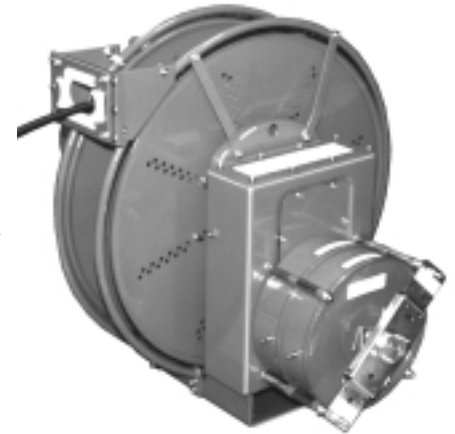
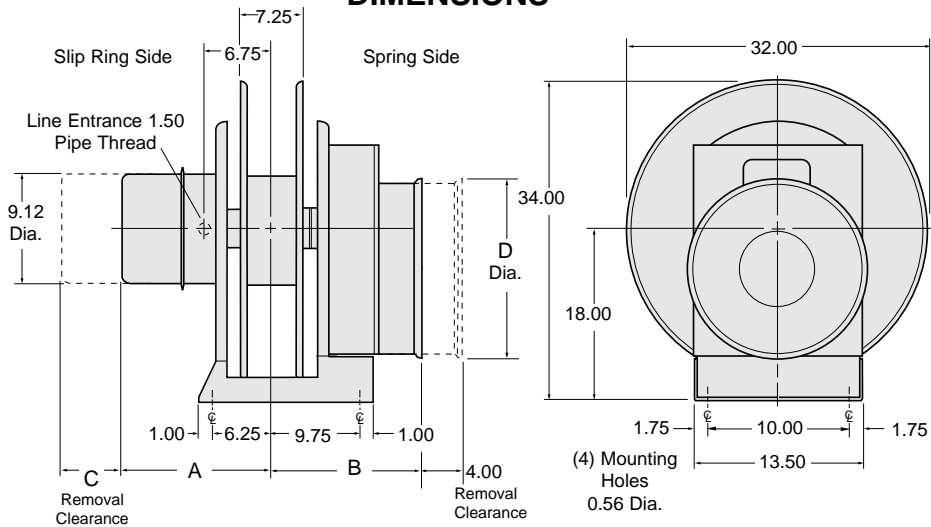

Cable payout, as pictured above, denotes standard rotation.

NOTE: Above illustration includes some of the optional accessories described below.

SLIP RING HOUSING DIMENSIONS

Second Series of Digits in Model Number

23	63	212	103	143	203	303
33	83	220	123	163	243	363
43	27	320	312	412		
	37	420				
	47					
"A" Dimension in Inches	16.00	18.50	21.00	23.50	28.50	36.50
"C" Dimension in Inches	8.50	11.00	13.50	16.00	21.00	29.00

SPRING MOTOR DIMENSIONS

MODEL NUMBER

"B" Dimension in Inches

"D" Diameter in Inches

Approximate Net Weight of Reel width Spring Motor(s)

MODEL NUMBER	S32801	S32802	S32803	S32804	S321001	S321002	S321003	S321004
"B" Dimension in Inches	14.38	17.88	21.38	24.88	15.25	18.75	22.25	25.75
"D" Diameter in Inches	14.38	14.38	14.38	14.38	14.38	14.38	14.38	14.38
Approximate Net Weight of Reel width Spring Motor(s)	225 lbs.	285 lbs.	350 lbs.	407 lbs.	240 lbs.	300 lbs.	370 lbs.	435 lbs.

OPTIONAL ACCESSORIES

Vertical Roller Guide
Part No. 04045401

If Hoop Guides are used, optional Roller Guides may be found on page 16.

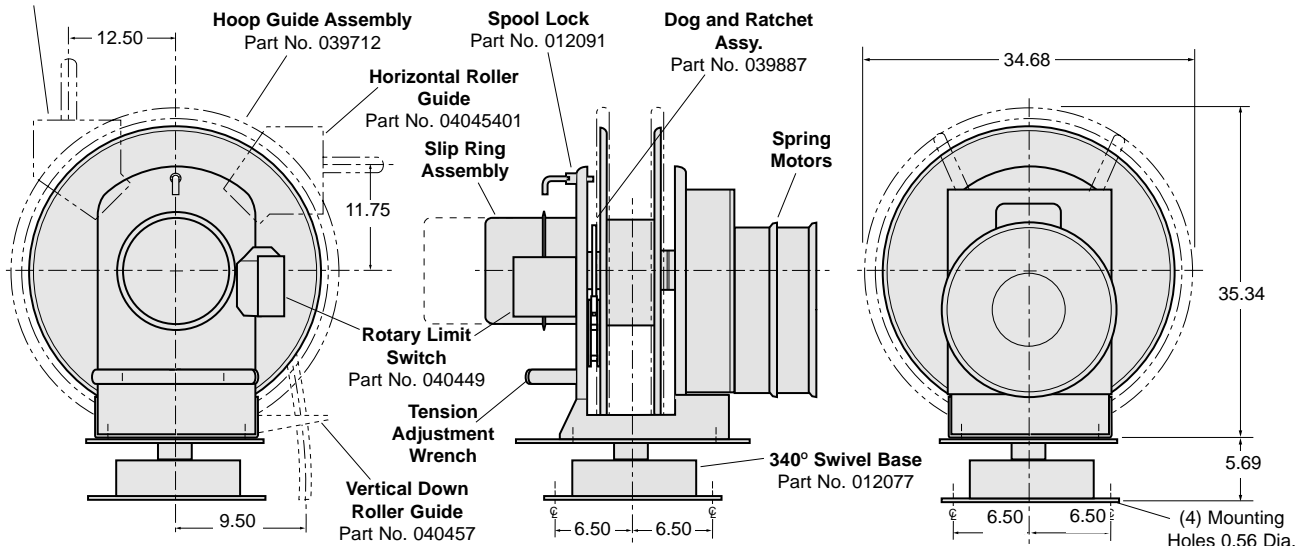

CONTINUOUS CONTACT WB REELS

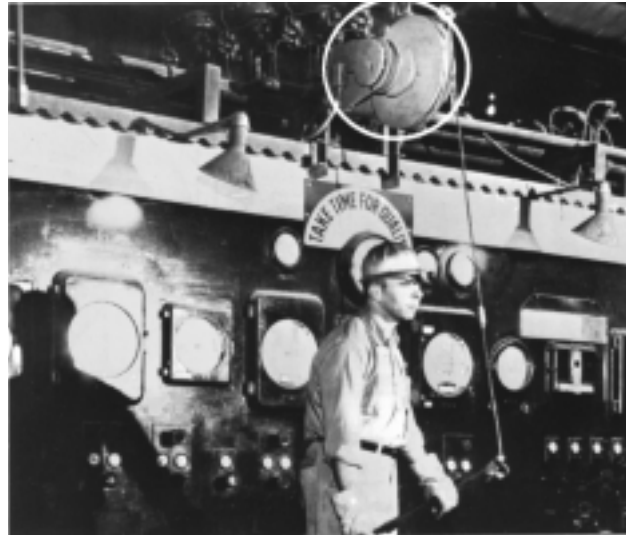
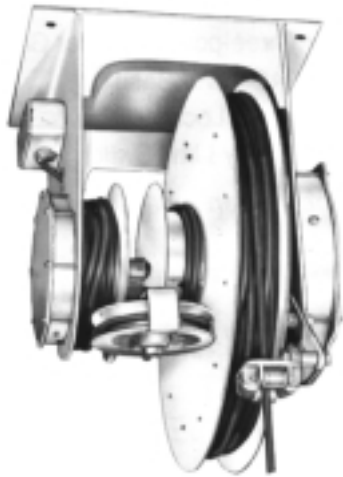

Gleason WB Reels are continuous contact reels ideal for use in applications where slip ring assemblies are not desired. No slip rings or other sliding contacts are used. Rather, a dual spool and pulley system safely and efficiently pays out and rewinds the cable.

The absence of electrical contact points on WB Reels make them an outstanding choice for applications involving portable or movable **communication** or **instrumentation** equipment. Such equipment could be adversely affected by the varying resistance of sliding electrical contacts or undue twisting of cords or cables resulting in varying imped-

ance. WB Reels are also a smart choice for **hazardous locations** where electrical parts on the reel would require dust-tight or explosion-proof protection.

A roller guide is included as standard equipment. A holding dog for window shade-type action can be furnished when required.

FIBER OPTIC CABLE of same approximate O.D. as SO shielded cable listed can be used with Series "WB" reels. Contact your factory representative for details.

WB Reels are selected using the standard process shown in the front of this catalog.

Reel models in selection charts based on travel speed of 150 fpm and 4 conductor shielded cable. Stretch reels based on 6% sag. Retrieve reels based on 3 ft lift to center line of reel.

Necessary reeling tensions suggest the use of high quality cable for good service life.

FOR CABLE SIZES NOT LISTED, CONSULT YOUR FACTORY REPRESENTATIVE.
MAXIMUM CABLE O.D. = 0.625"

WB REEL SELECTION CHARTS

Lift Reels

WIRE SIZE (AWG)	FEET OF ACTIVE TRAVEL									
	30	40	50	60	70	80	90	100	110	120
18	WB-60-25	WB-60-25	WB-60-25	WB-60-25	WB-60-25	WB-100-60	WB-100-60	WB-100-60	WB-100-60	WB-100-60
16	WB-60-25	WB-60-25	WB-60-25	WB-60-25	WB-75-25	WB-100-60	WB-100-60	WB-100-60	WB-100-60	WB-100-100-60
14	WB-60-25	WB-60-25	WB-75-25	WB-100-60	WB-100-60	WB-100-60	WB-100-60	WB-100-100-60	WB-100-100-60	WB-100-100-60

Stretch Reels (6% sag)

WIRE SIZE (AWG)	FEET OF ACTIVE TRAVEL									
	30	40	50	60	70	80	90	100	110	120
18	WB-60-25	WB-60-25	WB-60-25	WB-75-25	WB-75-25	WB-100-60	WB-100-60	WB-100-60	WB-100-60	WB-100-60
16	WB-60-25	WB-60-25	WB-60-25	WB-75-25	WB-100-60	WB-100-60	WB-100-60	WB-100-60	WB-100-60	WB-100-100-60
14	WB-60-25	WB-75-25	WB-100-60	WB-100-60	WB-100-60	WB-100-100-60	WB-100-100-60	WB-100-100-60	WB-100-100-60	WB-100-100-60

Retrieve Reels (3 ft mounting height)

WIRE SIZE (AWG)	FEET OF ACTIVE TRAVEL									
	30	40	50	60	70	80	90	100	110	120
18	WB-60-25	WB-60-25	WB-60-25	WB-60-25	WB-60-25	WB-60-25	WB-100-60	WB-100-60	WB-100-60	WB-100-60
16	WB-60-25	WB-60-25	WB-60-25	WB-60-25	WB-75-25	WB-100-60	WB-100-60	WB-100-60	WB-100-60	WB-100-100-60
14	WB-60-25	WB-60-25	WB-60-25	WB-100-60	WB-100-60	WB-100-60	WB-100-100-60	WB-100-100-60	WB-100-100-60	WB-100-100-60

Dimensional Data

FIBER OPTICS

Any fiber optic cable of the same approximate O.D. as SO shielded cable listed can be used with Series "WB" reels. Contact your local factory representative for details.

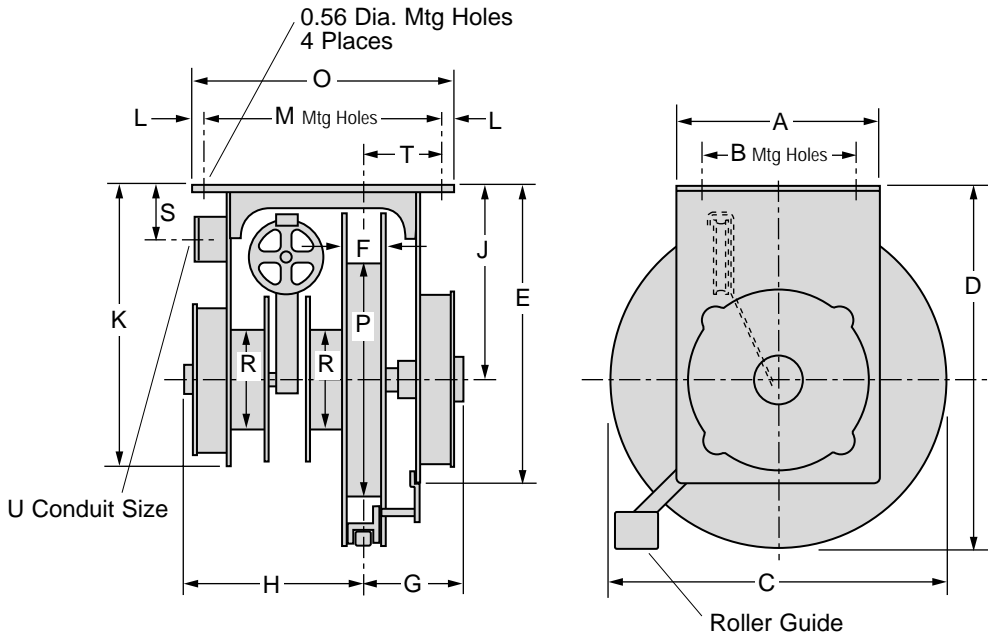

MODEL	A	B	C	D	E	F	G	H	J	K	L	M	N	O	P	R	S	T	U
WB-60-25	12.00	9.00	20.00	21.69	17.69	2.00	5.88	10.50	11.69	16.69	0.75	13.88	0.75	15.37	14.00	6.00	3.25	4.75	0.50
WB-75-25	12.00	9.00	27.00	28.69	20.75	2.00	6.81	10.75	15.19	19.69	0.75	13.88	0.75	15.37	22.00	6.00	6.69	4.63	0.50

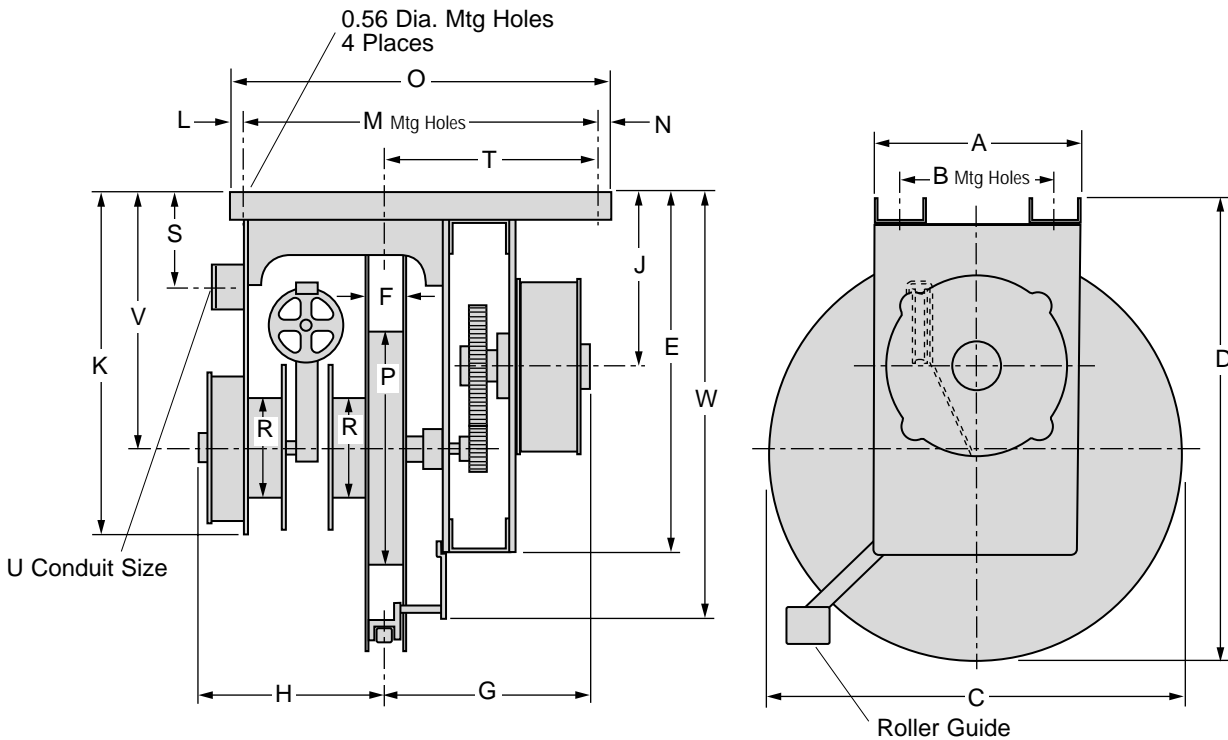

MODEL	A	B	C	D	E	F	G	H	J	K	L	M	N	O	P	R	S	T	U	V	W
WB-100-60	12.00	9.00	24.00	27.19	18.19	2.00	11.75	10.50	10.19	21.56	0.75	20.75	1.50	23.00	14.00	6.00	4.19	11.44	0.75	15.19	21.69
WB-100-100-60	12.00	9.00	28.00	31.19	20.19	2.00	16.00	10.75	12.19	23.56	0.75	20.75	1.50	23.00	16.00	6.00	6.00	11.44	0.75	17.19	23.69

Cable Length

Don't Cut Yourself Short!

REMINDER: Cable Length is NEVER equal to Active Travel or Total Travel.

CALCULATIONS FOR ORDERING OR CUTTING

$$\text{Cable Length} = \mathbf{1} + \mathbf{2} + \mathbf{3}$$

1 EXTRA CABLE AT REEL, shown in TABLE 1 or TABLE 2 on the facing page, is **REQUIRED** for internal connections and one safety wrap. The safety wrap is wound onto the reel.

2 ACTIVE CABLE is the amount of cable you will require to cover the Active Travel distance. **THIS CABLE IS WOUND ONTO THE REEL.** See "Selecting".

3 OVERHANG means any extra cable you require beyond Active Travel. **THIS CABLE MUST NOT BE WOUND ONTO THE REEL.** The reel is not designed to wind or lift the weight of this extra cable.

NOTE:
IF GLEASON SUPPLIES THE CABLE, correct cable length, rounded up to the nearest foot, is automatically calculated **based on your input.**

IF YOU ARE CUTTING YOUR OWN CABLE, please follow our calculation method shown on this page.

Reels in this catalog are calculated to handle factors **1** and **2** ONLY. If you have any **OVERHANG** (factor **3**), we will be happy to make specific reel model calculations for you.

EXAMPLES

Lift

A reel is needed for lifting 10C #14 cable. Active Travel is 40.0 ft. [Lift Selection Chart](#) shows Model No. S16801-103-9-1.

- Refer to Table 1 (right). Plotting a 9 inch diameter drum and slip ring assembly **103** specifies that this reel requires five extra feet of cable at the reel.
- Active Cable is equal to the 40.0 ft. of Active Travel.
- No overhang is required.

$$\begin{array}{r} \mathbf{1} = 5.0 \\ \mathbf{2} = 40.0 \\ \mathbf{3} = \underline{0} \\ \hline 45.0 \end{array}$$

Therefore:
CUT 45 FT.

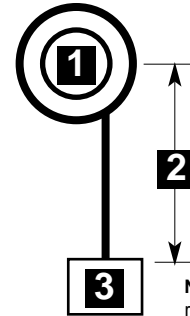

NOTE: If reel and cable will be required to lift (support) an added weight of any kind, this must be considered. Consult factory

Stretch

A reel is needed for stretching 10C #14 cable in one direction. Active Travel is 40.0 ft. [Stretch Selection Chart](#) shows Model No. S16801-103-9-1.

- Refer to Table 1 (right). Plotting a 9 inch diameter drum and slip ring assembly **103** specifies that this reel requires five extra feet of cable at the reel.
- Because of the 6% sag, Active Cable is *greater than* the 40.0 ft. of Active Travel.
 Active Cable = Active Travel x 1.01
 Active Cable = 40.0 x 1.01
 Active Cable = 40.4 ft.
- Overhang of 3.5 feet is required.

$$\begin{array}{r} \mathbf{1} = 5.0 \\ \mathbf{2} = 40.4 \\ \mathbf{3} = \underline{3.5} \\ \hline 48.9 \end{array}$$

Therefore:
CUT 49 FT.

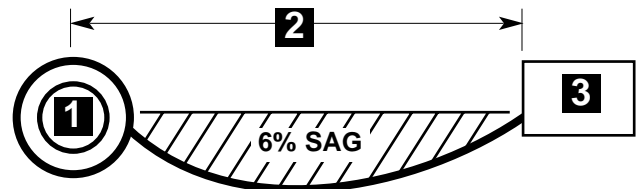

NOTE: Gleason S-Reel springs maintain sag at 6%. For greater sag factors, please consult us.

Retrieve

A reel is needed for retrieving 10C #14 cable. Active Travel is 40.0 ft. and reel is mounted 2.5 ft. above the ground (lift height). [Retrieve Selection Chart](#) shows Model No. S16621-103-9-5.

- Refer to Table 1 (right). Plotting a 9 inch diameter drum and slip ring assembly **103** specifies that this reel requires five extra feet of cable at the reel.
- Because of LIFT HEIGHT, Active Cable is *greater than* the 40.0 ft. of Active Travel.
 2.1 Active Travel = 40.0 ft.
 2.2 Lift Height = 2.5 ft.
 2.0 Active Cable = 40.0 + 2.5 = 42.5 ft.
- Overhang of 3.5 feet is required.

$$\begin{array}{r} \mathbf{1} = 5.0 \\ \mathbf{2} = 42.5 \\ \mathbf{3} = \underline{3.5} \\ \hline 51.0 \end{array}$$

Therefore:
CUT 51 FT.

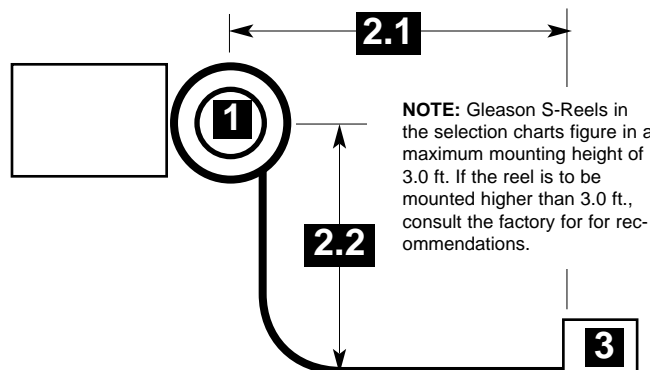

NOTE: Gleason S-Reels in the selection charts figure in a maximum mounting height of 3.0 ft. If the reel is to be mounted higher than 3.0 ft., consult the factory for recommendations.

TABLE 1

Series "S"

"EXTRA CABLE AT REEL" for Series "S" reels includes one safety wrap around the drum, cable through the shaft and cable connections to the slip ring leads.

When you have selected a reel model, the model number will indicate drum diameter and slip ring assembly code.

Using the lift example from the facing page:

Reel Model No.: **S16801 - 103 - 9 - 1**

Drum Dia.	EXTRA CABLE AT REEL (FEET)							
	4	5	5	5	6	6	6	5
8	4	5	5	5	6	6	6	5
9	5	5	5	6	6	6	7	5
10	5	5	6	6	6	7	7	5
11	5	6	6	6	7	7	7	6
12	6	6	6	7	7	7	8	6
13	6	6	7	7	7	8	8	6
14	6	7	7	7	8	8	8	7
15	7	7	7	8	8	8	9	7
16	7	7	8	8	8	9	9	7
17	7	8	8	8	9	9	9	8
18	8	8	8	9	9	9	10	8
19	8	8	9	9	9	10	10	8
20	8	9	9	9	10	10	10	9
21	9	9	9	10	10	10	11	9
22	9	9	10	10	10	11	11	9
23	9	10	10	10	11	11	11	10
24	10	10	10	11	11	11	12	10
23	63	103	203	243	303	363	27	412
33	83	123					37	220
43		143					47	320
		163					212	420
		312						

TABLE 2

Series "WB"

MODEL No.	EXTRA CABLE AT REEL (FT)
WB-60-25	Active Cable Length (ft) x 0.23 + 5
WB-75-25	Active Cable Length (ft) x 0.15 + 5
WB-100-60	Active Cable Length (ft) x 0.23 + 5
WB-100-100-60	Active Cable Length (ft) x 0.20 + 5

"EXTRA" CABLE AT REEL" for Series "WB" reels includes one safety wrap around the active cable drum, inactive cable to compensate for rotation of active drum and cable through the shaft. **EXAMPLE:** Model No. WB-60-25 with an active travel of 40.0 ft. will need (40 x 0.23) + 5 feet of cable, rounded up. 40 x 0.23 = 9.2; 9.2 + 5 = 14.2; 14.2 rounded up = 15 feet **EXTRA** cable required.

SLIP RING ASSEMBLY

Type SO Cable—600 Volt

16 AWG			14 AWG			12 AWG			10 AWG		
No. Cond.	Dia. In.	Weight lb/ft	No. Cond.	Dia. In.	Weight lb/ft	No. Cond.	Dia. In.	Weight lb/ft	No. Cond.	Dia. In.	Weight lb/ft
2	0.374	0.094	2	0.512	0.158	2	0.586	0.204	2	0.638	0.250
3	0.393	0.110	3	0.538	0.184	3	0.616	0.244	3	0.671	0.310
4	0.427	0.144	4	0.584	0.224	4	0.668	0.282	4	0.730	0.371
5	0.510	0.156	5	0.665	0.260	5	0.725	0.322	5	0.796	0.425
6	0.565	0.178	6	0.710	0.302	6	0.805	0.380	6	0.883	0.485
7	0.605	0.202	7	0.710	0.329	7	0.865	0.435	7	0.982	0.593
8	0.645	0.222	8	0.770	0.373	8	0.920	0.475	8	1.052	0.650
9	0.720	0.268	9	0.820	0.414	9	1.020	0.550	9	1.127	0.725
10	0.720	0.278	10	0.885	0.434	10	1.020	0.581	10	1.127	0.760
12	0.740	0.305	12	0.905	0.481	12	1.050	0.645	12	1.153	0.850
14	0.775	0.348	14	1.000	0.556	14	1.105	0.743	14	1.287	1.118
16	0.825	0.386	16	1.050	0.657	16	1.160	0.840	20	1.455	1.400
18	0.860	0.430	18	1.110	0.715	18	1.227	0.925			
20	0.900	0.466	20	1.150	0.785	20	1.287	1.005			
22	0.940	0.503	22	1.210	0.857	22	1.370	1.140			
24	1.015	0.564	24	1.320	0.920	24	1.443	1.225			
26	1.015	0.604	26	1.350	0.986						
28	1.070	0.654	28	1.370	1.098						
30	1.070	0.677	30	1.390	1.138						
32	1.120	0.714									
34	1.155	0.807									
36	1.155	0.820									

Type W Cable—600 Volt

AWG Size	No. Cond.	Dia. In.	Weight lb/ft
8	2	0.788	0.328
	3	0.894	0.470
	4	0.966	0.583
6	2	0.872	0.425
	3	0.983	0.614
	4	1.068	0.769
4	2	1.040	0.780
	3	1.068	0.797
	4	1.166	1.019
2	2	1.177	0.888
	3	1.244	1.152
	4	1.326	1.429
1	2	1.365	1.090
	3	1.413	1.491
	4	1.548	1.877
1/0	2	1.454	1.386
	3	1.539	1.805
	4	1.686	2.309

Type G-GC Cable—600 Volt

AWG Size	No. Cond.	Dia. In.	Weight lb/ft
8	3	0.915	0.661
6	3	1.000	0.792
4	3	1.120	1.088
2	3	1.250	1.436
1	3	1.440	1.856

Type SO Shielded Cable—600 Volt

AWG Size	No. Cond.	Dia. In.	Weight lb/ft
18	4	0.422	0.122
16	4	0.447	0.165
14	4	0.605	0.257

Whenever possible, refer to specific manufacturer's information regarding cable. If this information is not available, these charts are composites and may be used as guides to typical cable sizes and weights.

Refer to National Electric Code for ampere ratings and other details.

Cable Management

Since 1911, Gleason Reel Corp. has been in the business of CABLE MANAGEMENT. Our products are designed to convey and protect valuable cables and hoses that power and control moving machines of all types. They improve productivity and safety on the job by moving cables and hoses away from hazardous locations on machinery or the shop floor into a controlled environment. Whether you choose Reels for efficient storage and payout from virtually any angle, Festoon Systems for overhead applications or PowerTrak® for protection on machinery in motion, your cables and/or hoses will last longer and provide better service with a cable management system from **Gleason Reel Corp...**

...The Cable & Hose Management Company!

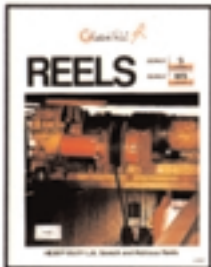

Bulletin "CR"
Heavy Duty
Spring Driven
Electric Cable Reels
General Industrial



Bulletin "MR"
Extra Heavy Duty
Spring Driven
Electric Cable Reels
Demanding Service



Bulletin "VMR"
Large Retrieving
Motor Driven
Electric Cable Reels
Heavy Duty Industrial



Bulletin "RET"
Long Travel Length
Motor Driven
Electric Cable Reels
Standard Industrial



Bulletin "PSR"
Lifting & Lowering
Motor Driven
Electric Cable Reels
Push-Button Reels



**Cable and Hose Reels
for Emergency Vehicles
Specialty Reels**

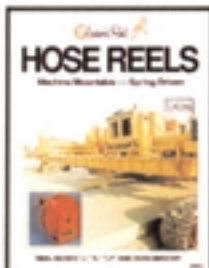

Bulletin "HRM"
Various Types
Spring Driven
Hose Reels
General Industrial



Bulletin "SR"
Slip Rings
Unitized Design
Low & High Amperage
Low & Medium Voltage



Bulletin "PTG"
Non-Metallic
Cable Chain
For Hose & Cable
Lightweight, Economical

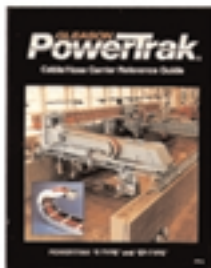

Bulletin "PT"
Rugged Steel
Cable Chain
For Hose & Cable
Standard & Mill Duty



Bulletin "FC"
Rugged Steel
C-Rail Mounted
Festoon Systems
General Industrial



Bulletin "FB"
Heavy Duty
I-Rail Mounted
Festoon Systems
Heavy Duty Port Types



Gleason Reel Corp.

P.O. Box 26 • 600 South Clark St.
Mayville, Wisconsin 53050-0026
Phone: 920-387-4120
Fax: 920-387-4189

In your area contact: