

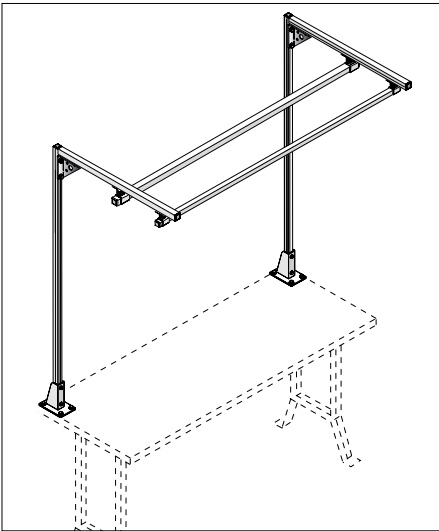

# UPDATE YOUR EXISTING BENCH

Easily, quickly, inexpensively retrofit old "beaters" as well as new benches.



## KITS

Hubbell Workplace Solutions kits contain everything needed to assemble ergonomically sound fixed workstations or mobile productivity boosters. All fasteners are included, with most already in place. The only tools required are two wrenches and a tape measure (drilling may be required to secure workstation to some benches). To complete assembly, attach bases to the bench (three styles of bases are available), slide components into position and tighten hardware. Fully customize with readily available components and accessories to make each workstation fit the task and fit the people performing the task. That's practical, affordable ergonomics.



Older bench equipped with new workstation kit and optional accessories.

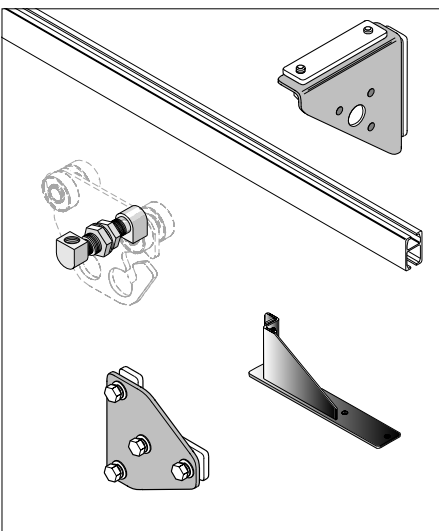

## COMPONENTS

Most components which make up Hubbell Workplace Solutions kits are available separately. Components are often added to basic kits, further customizing them to fit the task. Components may also be used to construct workstations or other equipment using the practical "slide & clamp" assembly method. Where applicable, components include track nuts or clamp bars, plus other hardware, required for assembly.

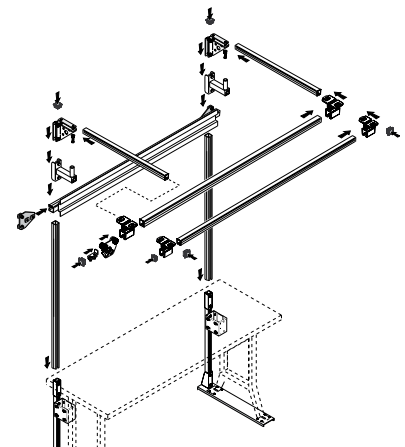

Kits, components and accessories assemble easily. Just slide into place and tighten.



## ACCESSORIES

Hubbell Workplace Solutions workstation accessories increase utilitarian value and make the workplace more user friendly by adding functions. Typical accessories include; adjustable swing arms with a variety of attachments, torque neutralizing arms and tool positioners, air manifolds, bars for holding plastic tote bins, shelves, and lights. Accessories can be installed easily on HWS fixed or portable workstation kits.



Mobile productivity booster kits are complete, including all hardware. Assembly is required.



# SINGLE COLUMN WORKSTATION KITS

## SWING OR FIXED BOOMS

**SINGLE COLUMN KITS** are the efficient and economical way to meet ergonomic requirements. Each kit is complete with 180° swing or fixed boom, safety hook or balancer trolley and Universal Bracket for mounting everything from an air line fitting to peg board. Some models also include tool balancer, coiled air line, brass air line fitting and cord grip for use with electric tools. It's ready to mount on your work bench then customize...add swing arms with attachments, as shown below right, or other items as required. Horizontal boom has rated maximum capacity of 30 lbs.(13.5 kg). Bolts to any bench top. Hardware for mounting jib to bench not included. Balancer is easily adjusted to support tool weight allowing maximum productivity with minimum effort. Tool not included.



**36" SWING BOOM KIT WITH TOOL TROLLEY**  
Except for tool and hardware to attach jib to your bench top, what you see here is what you get. Swing arms may be installed on 36" jib kits.

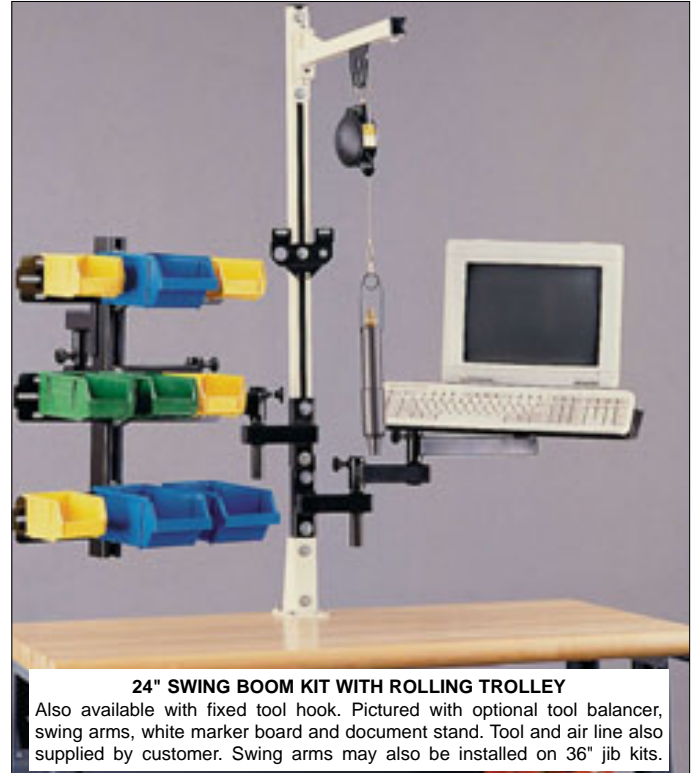

**24" SWING BOOM KIT WITH ROLLING TROLLEY**  
Also available with fixed tool hook. Pictured with optional tool balancer, swing arms, white marker board and document stand. Tool and air line also supplied by customer. Swing arms may also be installed on 36" jib kits.

**36" (914mm) LONG BOOM WORK STATION KIT** (above, left) includes (1) fixed or swing 3 ft. WS30 swing boom, (1) 5 ft. WS50 vertical column, (1) 1.5, 2.5, or 5.0 lb.tool balancer, (1) balancer trolley, (1) end stop (with trolley only), (2) end caps, (1) #WS-UH universal bracket, (1) brass air fitting, (1) cord grommet, (1) coiled 1/4" air line, (1) mounting base, all hardware required for assembly. Mounting fasteners not included. Does not include tool.

**24" (610mm) LONG BOOM WORK STATION KIT** (above, right) includes (1) fixed or swing 2 ft. WS30 boom, (1) 4 ft. WS50 vertical column, (1) balancer trolley or end stop hook, (1) end stop (with trolley only), (2) end caps, (1) angle bracket (fixed boom only), (1) #WS-UH universal bracket, (1) mounting base, and all assembly hardware. Does not include fasteners for mounting base to bench. Does not include swing arms, balance reel, tool, air line or fittings shown in illustration.

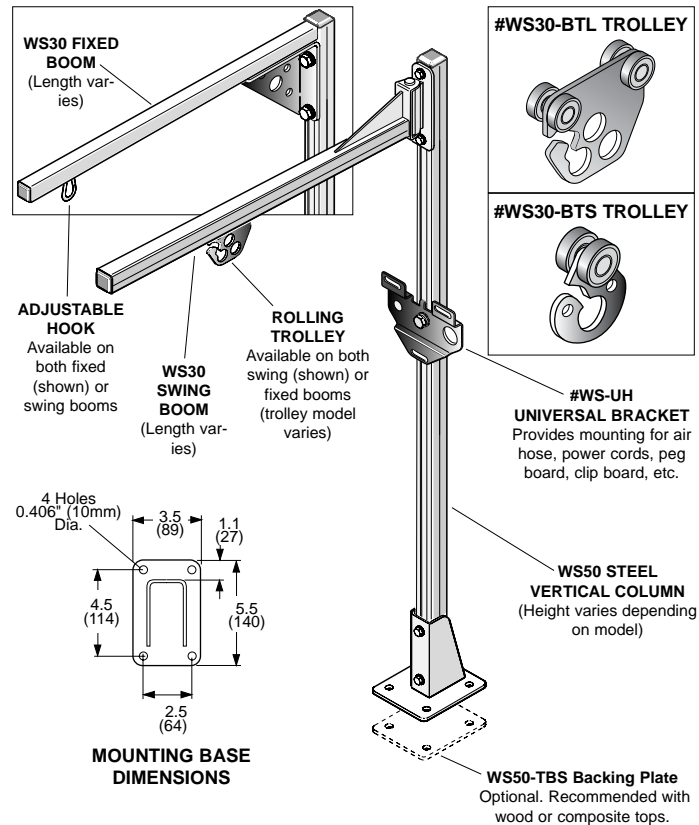

**WS30 boom for total loads to 30 lbs. (13.5 kg)**

Min.-Max. BALANCER CAPACITY	TROLLEY MODEL NUMBER	BOOM LENGTH & TYPE	VERTICAL COLUMN HEIGHT	WITH HOOK MODEL NO.	WITH TROLLEY MODEL NO.
0.5-1.5 lbs.	WS30-BTS	36" Swing	5' (1.5m)	na	WTS-050301
1.5-3.0 lbs.	WS30-BTS	36" Swing	5' (1.5m)	na	WTS-050302
3.0-5.0 lbs.	WS30-BTS	36" Swing	5' (1.5m)	na	WTS-050305
0.5-1.5 lbs.	WS30-BTS	36" Fixed	5' (1.5m)	na	WTF-050301
1.5-3.0 lbs.	WS30-BTS	36" Fixed	5' (1.5m)	na	WTF-050302
3.0-5.0 lbs.	WS30-BTS	36" Fixed	5' (1.5m)	na	WTF-050305
na	WS30-BTL*	24" Swing	4' (1.2m)	WHS-020400	WTS-020400
na	WS30-BTL*	24" Fixed	4' (1.2m)	WHF-020400	WTF-020400

\* Only on models supplied with trolley.

# TOOL RAIL KITS

## DUAL RAIL, DUAL COLUMN, BENCH SUPPORTED

KITS



Workplace Solutions

**DUAL COLUMN WORKSTATION KITS** include two straight rails, your choice of three mounting base styles and in a range of heights to fit virtually any bench and any task you have. Height of horizontal support rails is adjustable, as is position of rails and width (distance between vertical columns). Kits include one WS30 and one WS50 rail. Either or both may be used as tool rail by adding **optional** balancer trolleys. Trolley mounted TORQ-ARM™ may be used, as can most accessories. Additional components may be added to make these workstations even more functional. Consult your Hubbell Workplace Solutions distributor or contact the factory for more details.

**TOOL RAIL KITS** include (1) WS30 rail with hangers, (1) WS50 rail with hangers, (2) WS50 vertical columns, (2) WS50 horizontal 36" rails, (2) angle brackets with hardware, (2) bases as shown, (4) end stops, (8) end caps, and all assembly hardware.

### WS-50 SUPPORT RAILS

3 ft.(0.9m) long. Reach full depth of bench. End caps included.

### WS30 and WS50 TOOL RAILS

4', 5', or 6' (1.2, 1.5, 1.8m) length. Include hangers, end stops, and end caps.

**BENCH LEG KIT** is highly popular because of its superior rigidity and durability. The bench becomes a movable workstation.

### WS50 VERTICAL COLUMNS

### #WS50-UF30 or WS50-UF36 BENCH LEG BASES

Bolt or weld to bottoms and back uprights of legs. Mounting bracket fully adjustable. Available for 30"(762mm) or 36"(914mm) bench depth. Base predrilled to fit most standard benches cataloged by Edsal, Equipto, Lyon, Penco and similar.

### STRAIGHT RAIL BENCH LEG KITS

RAIL WIDTH ft. (m)	HEIGHT ABOVE FLOOR	
	7 ft.(2.1m) (1)	7 ft.(2.1m) (1)
	30"(762) BASE	36"(914) BASE
4.0 (1.2)	#WKF-030740	#WKF-030746
5.0 (1.5)	#WKF-030750	#WKF-030756
6.0 (1.8)	#WKF-030760	#WKF-030766

**NOTE 1:** Nominal floor to top of vertical rail is 7'(2.1m). For 8'(2.4m) high models, change 7 in model number to 8, ie: WKF-030840.

### BENCH TOP

#WS50-TB base. Best mounted to butcher-block tops.

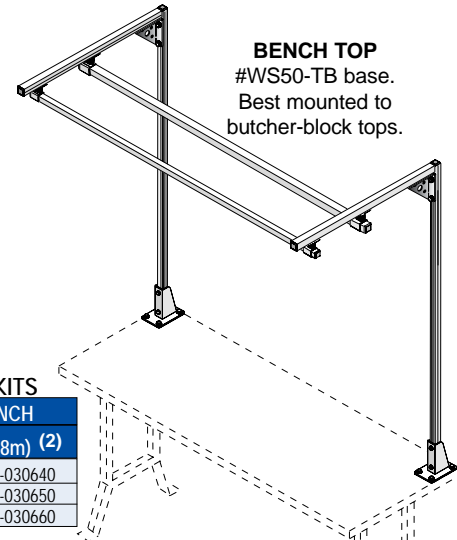

### STRAIGHT RAIL BENCH TOP KITS

RAIL WIDTH ft. (m)	HEIGHT ABOVE BENCH	
	5 ft.(1.5m) (2)	6 ft.(1.8m) (2)
4.0 (1.2)	#WGB-030540	#WGB-030640
5.0 (1.5)	#WGB-030550	#WGB-030650
6.0 (1.8)	#WGB-030560	#WGB-030660

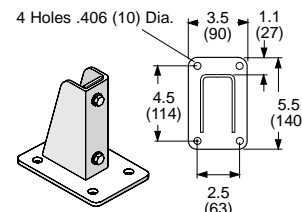

### MOUNTING BASE DIMENSIONS

**WS50-TBS** Backing Plate (Same size as Mounting Base) Optional

### TABLE BRACKET

#WS50-BBR and WS50-BBL bases. Predrilled to fit Equipto and Lyon steel tops.

### STRAIGHT RAIL TABLE BRACKET KITS

RAIL WIDTH ft. (m)	HEIGHT ABOVE BENCH	
	5 ft.(1.5m) (2)	6 ft.(1.8m) (2)
4.0 (1.2)	#WKB-030540	#WKB-030640
5.0 (1.5)	#WKB-030550	#WKB-030650
6.0 (1.8)	#WKB-030560	#WKB-030660

**NOTE 2:** Height of bench will determine Tool Rail height.

### #WS50-BBR Right-Hand

### #WS50-BBL Left-Hand

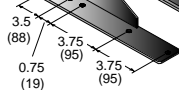

### MOUNTING BASE DIMENSIONS

**WS50-BBS** Backing Plate (Same size as Mounting Base) Optional

### BALANCER TROLLEY

#WS30-BTL for WS30 rail.  
#WS50-BTL for WS50 rail.  
Order separately.

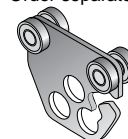



# CURVED RAIL FOLLOWS THE WORK GUIDES TOOLS AND CONTROLS AROUND CORNERS

UNIQUE DIAMOND RAIL track and matching trolleys allow tools or control boxes to follow assembly line or conveyor path. Curved sections with 3 ft. (0.9m) radius form 90° corner and connect to other curved or straight track sections for smooth, non-stop trolley movement. Design and build your own system from components shown below. Threaded hangers may be hung from overhead beams or from WS50 rail using standard track nut. Trolleys include safety flanges to prevent fall if rollers fail. Capacity 30 lbs. (13.5 Kg).

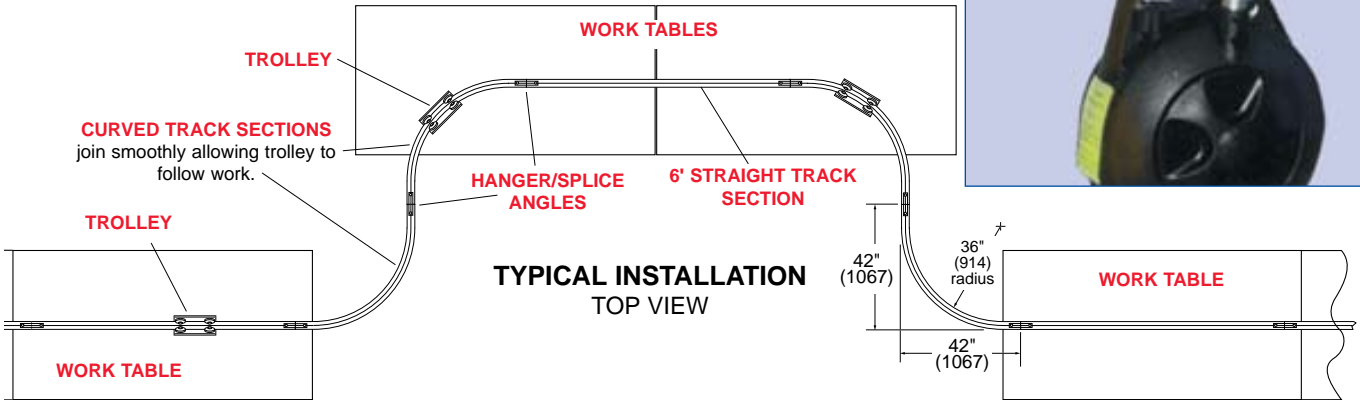
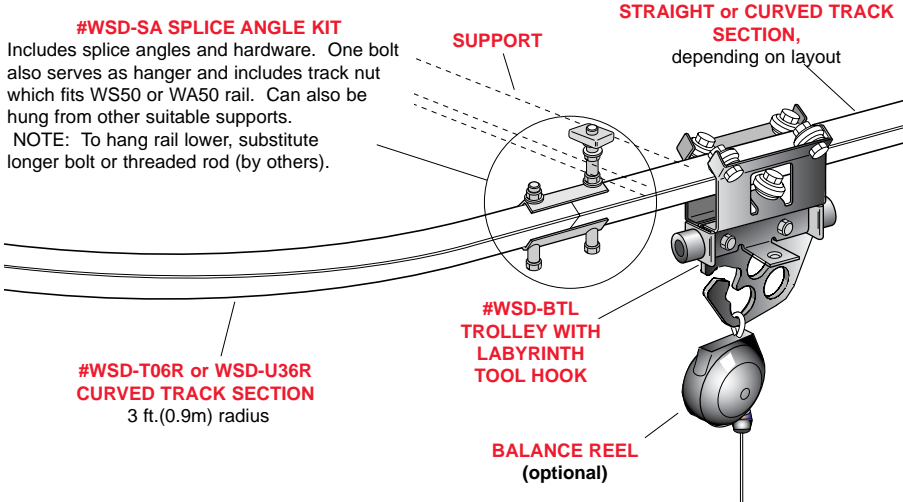

## COMPONENT CHART

DESCRIPTION	FINISH	MODEL NO.
6' (1.8m) STRAIGHT TRACK SECTION	BEIGE POLYESTER	WSD-T06
	UNFINISHED	WSD-U06
90° x 36" (914mm) Radius CURVED TRACK SECTION	BEIGE POLYESTER	WSD-T36R
	UNFINISHED	WSD-U36R
SPLICE ANGLE KIT includes (2) angles, hanger bolt, splice bolt, nuts & washers	ZINC PLATED	WSD-SA
END STOP KIT (right, top) includes end stop, hanger bolt, nuts & washers	ZINC PLATED	WSD-ES
TROLLEY-LABYRINTH TOOL HOOK	BLACK POLYESTER	WSD-BTL
FESTOON TRAILER TROLLEY*	BLACK POLYESTER	WSD-RC12

\* **FESTOON TRAILER TROLLEY** (right, bottom) provides easy management of cord or hose supplying power to tool. Fits cable or hose 0.60–0.94" (15–24mm) diameter. Tow cable connecting tool trolley to trailer trolley should not exceed 24" in length.

