

Installation/Operation Instructions

Typical Dimensions

Specifications*

Model Number	940-XX-1E**	940-XX-2E**	940-XX-3E**
Output Signal	0-10 vdc	10-0 vdc	4-20 mA Loop Power
Supply Voltage	15-26 vdc	15-26 vdc	n.a.
Supply Current	50 mA Max	50 mA Max	n.a.

Position Accuracy	0.1% of Full Stroke (Min. 0.05")
Non-Linearity	+/- 0.05% of Full Scale
Repeatability	0.01% of Full Stroke
Temperature Rating	
Head Electronics	-20 to 70°C (-4 to 158°F)
Guide Tube	-40 to 85°C (-40 to 185°F)
Pressure Rating	+3000 PSIG Operation in Hydraulic Fluid and +8000 PSIG Peak
Sensor Length	3", 6", 12", 18", 24", 36", 72", 96"
Enclosure	NEMA 12, 13 IP 65

* Specifications subject to change without notice.

** In place of "XX" insert sensor length in inches.

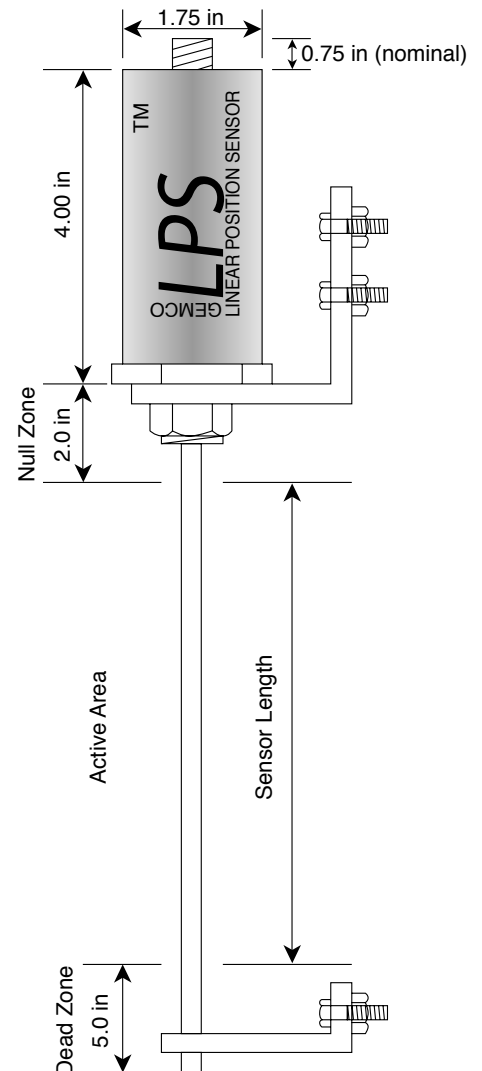

Operation

The active area of the sensor lies between Null Distance and the Dead Zone. Sensors are sold by "active sensor length" and overall sensor length increases by the Dead Zone and Null Distance. The sensor must be applied such that the magnet, over its maximum excursion, remains within the active area.

Maximum analog output occurs when the magnet target is moved to the Dead Zone boundary. Minimum analog output occurs with the magnet target at the Null Distance boundary. There are no adjustments needed or possible with the model 940 Gemco LPS Sensor. Off-set, pre-sets and signal inversion can be done through programming of the programmable controller, or by using the LPS input to the Gemco 949-001 model control unit.

Typical Installation

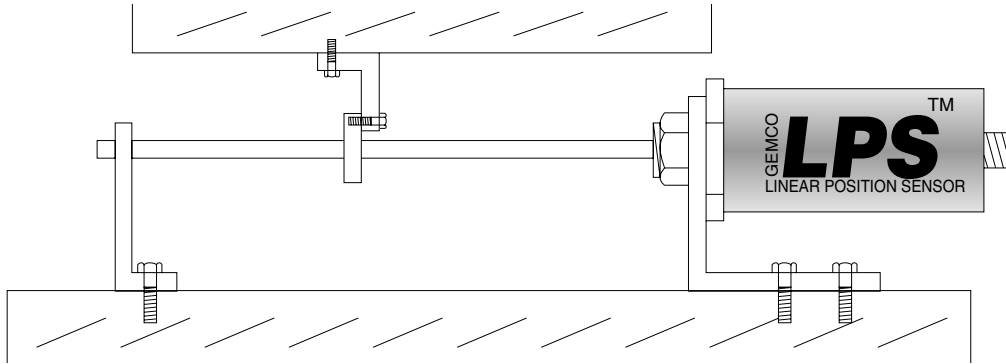

Use Mounting Kit No. 949-002 which includes the head “L” bracket and the probe support bracket. The magnet support bracket is provided with the magnet kit. It is important to use the mounting kit hardware provided, or to follow the following instructions:

Important

In instances where the magnet will be mounted to a ferrous surface, spacers manufactured of non-ferrous materials (such as stainless steel, nylon, etc.) should be used. The spacer should be designed in such a way that any ferrous surface is no closer than 0.25" from magnet. Ferrous material within 0.25" of the magnet will distort the magnetic flux and adversely affect the units operation.

Wiring Diagrams

Use Euro Connector (micro 12 mm single keyway) cordsets, available from most connector manufacturers or purchased from Patriot. Install according with the following diagrams:

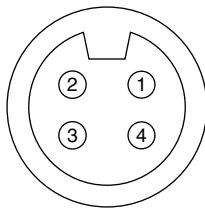
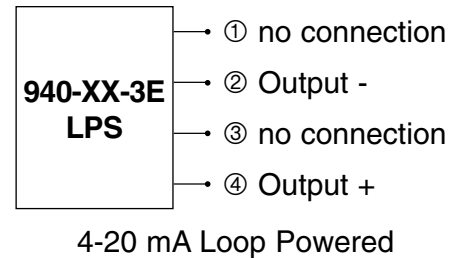
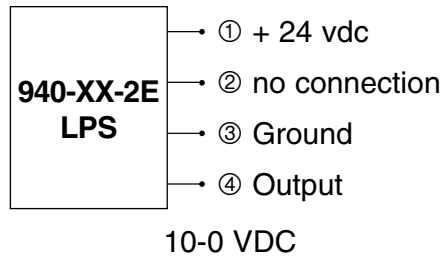
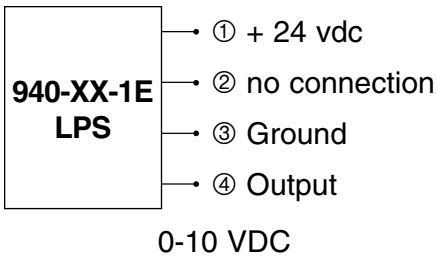

Euro Connector
(micro 12 mm single keyway)

Warning Warning Warning Warning Warning Warning

A switch in a protective interlocking circuit should be used with at least one other device that will provide a redundant protective function, and the circuit should be so arranged that either device will interrupt the intended operation of the controlled equipment. (NEMA ICS 2-225.95)

Servicing energized industrial control equipment can be hazardous. Severe injury or death can result from electrical shock burn or unintended actuation of controlled equipment.

Recommended practice is to disconnect and lock out control equipment from power sources and discharged stored energy in capacitors, if present, if it is necessary to work in the vicinity of energized equipment. Only qualified personnel should be permitted to perform such work, using all applicable safety practices and protective equipment.

AMETEK®
PATRIOT SENSORS

1080 NORTH CROOKS ROAD • CLAWSON, MI 48017 USA
800-635-0289 • 248-435-0700 • Fax 248-435-8120
www.patriotsensors.com • www.ametek.com

940.11
9/99 • Z80
2M