

HITACHI INVERTER

SJ300 / L300P SERIES

SERVICE MANUAL

After reading this manual , keep it hand for future reference.

HITACHI

NBS611CX

Spec Tech Industrial 203 Vest Ave. Valley Park, MO 63088 Phone: 888 SPECTECH
Email: sales@spectechind.com www.spectechind.com

Revision History Table

No.	Revision Contents	The Date of Issue	Operation Manual No.
1	Japanese font was removed.	Nov. 2000	NBS611BX
2	The specification of the capacity 75-132kW and more was added.	Mar. 2001	NBS611CX

Table of contents

1. Investigation of the inverter

1.1 Specification label(Model name , Manufacturing number ; MFG)

1.1.1 Model name 1-1

1.1.2 MFG number 1-1

1.2 Inverter specification

1.2.1 SJ300 1-2

1.2.2 L300P 1-10

2. Trouble shooting

2.1 INV trip contents , remedy , advice 2-1

2.2 Option error

2.2.1 Feed-back board (SJ-FB) 2-3

2.2.2 Digital-input option board (SJ-DG) 2-3

2.2.3 Device-Net option board (SJ-DN) 2-3

2.3 Check of the trip monitor contents 2-4

2.4 Confirmation of the warning monitor contents 2-5

2.5 Return to an initialization setup (Factory-shipment state) 2-6

3. Debug mode

3.1 Monitor mode 3-1

3.2 Function mode 3-2

3.3 Parameter settings for inverter 3-3

4. The check of control power supply voltage and a control signal

4.1 Control power supply voltage 4-1

4.2 Control signal 4-1

5. Maintenance and Inspection

5.1 Maintenance and Inspection

5.1.1 Daily inspection 5-1

5.1.2 Cleaning 5-1

5.1.3 Periodical inspection 5-1

5.2 Daily and annual maintenance 5-2

5.3 Megger test 5-3

5.4 Withstand voltage test 5-3

5.5 How to check inverter , converter , BR and Thyristor portion 5-4

5.6 Parts replacement 5-5

5.7 Unit replacement 5-8

Appendix

Circuit Diagram

Internal block diagram

Structure figure

1. Investigation of the inverter

1.1 Specification label (Model name, Manufacturing number : MFG)

- There are 2 specification label attached to the inverter as shown in Fig 1-1.

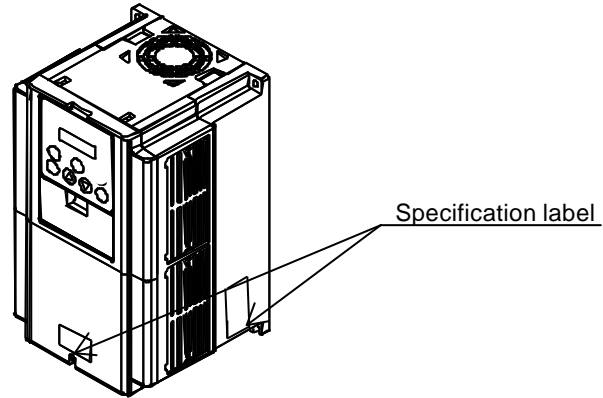

Fig 1-1 Specification label location

- Please confirm the model name and MFG number from the specification label as follows.

Model name	→	HITACHI Model: SJ300-055HF
Applicable motor	→	kW/HP: 5.5 / 7.5
Input ratings	→	Input/Entrée: 50Hz, 60Hz: 400-480 V 1 Ph A 50Hz, 60Hz: 400-480 V 3 Ph 13 A
Output ratings	→	Output/Sortie: 0, 1-400Hz: V 3 Ph 12 A
MFG number	→	MFG No. P4A71234590001 Date: 0904 Hitachi, Ltd. MADE IN JAPAN NE10909-27

Fig 1-2 contents of specification label

1.1.1 Model name

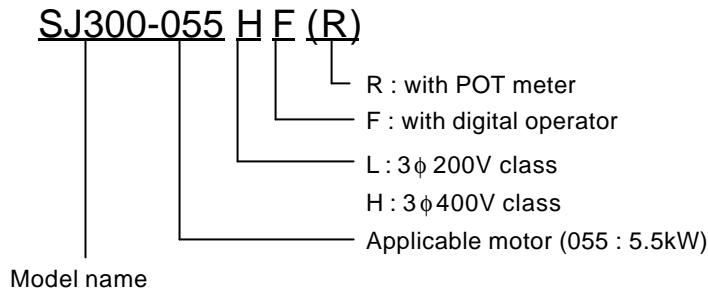

1.1.2 MFG number

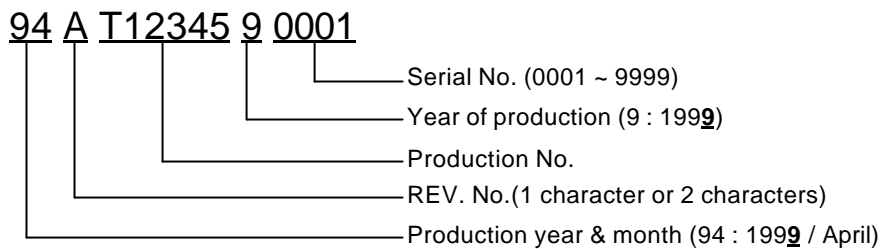

1.2 Inverter specification

1.2.1 SJ300

(Note1)

Monitor Mode

Display code	Function name	SJ300 monitor or data range (digital operator)	Initial data	Note
d001	Output frequency monitor	0.00-99.99/100.0-400.0(Hz)	-	
d002	Output current monitor	0.0-999.9(A)	-	
d003	Operation direction monitor	F(forward)/o(stop)/r(reverse)	-	
d004	PID feedback monitor	0.00-99.99/100.0-999.9/1000. -9999. / 1000-9999/Γ100-Γ999 (10000-99900)	-	
d005	Intelligent input terminal monitor	<p>(Example) FW, terminal 7,2, 1: ON Terminal 8,6,5,4,3:OFF</p>	-	
d006	Intelligent output terminal monitor	<p>(Example) Terminal 12,11:ON AL, 15,14,13:OFF</p>	-	
d007	Frequency conversion monitor	0.00-99.99/100.0-999.9/1000. -9999. / 1000-3996	-	
d012	torque monitor	-300.-+300.%	-	
d013	Output voltage monitor	0.0-600.0 V	-	
d014	Input electric power monitor	0.0-999.9 kW	-	
d016	Accumulated time monitor during RUN	0.-9999./1000-9999/Γ100-Γ999 h	-	
d017	Power ON time monitor	0.-9999./1000-9999/Γ100-Γ999 h	-	
d080	Number of trip time monitor	0.-9999./1000-6553(10000-65530) (time)	-	
d081	Trip monitor 1	Trip Code, frequency(Hz), current(A), voltage(V),RUN time(h) power ON time(h)	-	
d082	Trip monitor 2		-	
d083	Trip monitor 3		-	
d084	Trip monitor 4		-	
d085	Trip monitor 5		-	
d086	Trip monitor 6		-	
d090	Warning monitor	Warning code	-	
F001	Output frequency setting	0.0, starting frequency-Max. frequency (2 nd max. 3 rd max. frequency)(Hz)	0.00	
F002	1 st acceleration time	0.01-99.99/100.0-999.9/1000. -3600.(s)	30.00	
F202	2 nd acceleration time	0.01-99.99/100.0-999.9/1000. -3600.(s)	30.00	
F302	3 rd acceleration time	0.01-99.99/100.0-999.9/1000. -3600.(s)	30.00	
F003	1 st deceleration time	0.01-99.99/100.0-999.9/1000. -3600.(s)	30.00	
F203	2 nd deceleration time	0.01-99.99/100.0-999.9/1000. -3600.(s)	30.00	
F303	3 rd deceleration time	0.01-99.99/100.0-999.9/1000. -3600.(s)	30.00	
F004	Operation direction selection	00(forward)/01(reverse)	00	

(Note1) Change mode during run by selection of b031 (software lock selection).

(Note2) Do not forget to press "STR" key when you change the display.

Function Mode

Code	Function name	SJ300 Setting range	Initial data -FE/-FU/-F	Note
Base setting	A001	Frequency setting selection	01(terminal)/02(operator)/03(RS485)/04(option1)/05(option2)	01/01/02
	A002	Operation setting selection	01(terminal)/02(operator)/03(RS485)/04(option1)/05(option2)	01/01/02
	A003	Base frequency	30. -Maximum. frequency(Hz)	50./60./60.
	A203	Base frequency, 2nd motor	30. - 2nd Maximum. frequency (Hz)	50./60./60.
	A303	Base frequency, 3rd motor	30. - 3rd Maximum. frequency (Hz)	50./60./60.
	A004	Maximum frequency	30. - 400. (Hz)	50./60./60.
	A204	Maximum frequency, 2nd motor	30. - 400. (Hz)	50./60./60.
	A304	Maximum frequency, 3rd motor	30. - 400. (Hz)	50./60./60.
Analog input setting	A005	AT terminal selection	00(Changing of O and OI with AT terminal)/ 01(Changing of O and O2 with AT terminal)	00
	A006	O2 selection	00(single)/01(auxiliary speed of O, OI) [no reversible] / 02(auxiliary speed of O, OI [reversible]	00
	A011	0 start	0.00-99.99/100.0-400.0 (Hz)	0.00
	A012	0 end	0.00-99.99/100.0-400.0 (Hz)	0.00
	A013	0 start rate	0.-100.0 (%)	0.
	A014	0 end rate	0.-100.0(%)	100.
	A015	0 start selection	00 (external starting frequency)/01(0Hz)	01
	A016	O, OI, O2 sampling	1.-30.(times)	8.
Multistage speed,jogging, frequency setting	A019	Multi-speed selection	00(binary : range is to 16 stage speed with 4 terminals)/ 01(bit : range is to 8 stage speed with 7 terminals)	00
	A020	Multi-speed 0	0.00, starting frequency-maximum. frequency(Hz)	0.00
	A220	Multi-speed 0, 2 nd motor	0.00, starting frequency-2 nd maximum frequency(Hz)	0.00
	A320	Multi-speed 0, 3 rd motor	0.00, starting frequency-3 rd maximum frequency(Hz)	0.00
	A021	Multi-speed1	0.00, starting frequency-maximum frequency(Hz)	0.00
	A022	Multi-speed2	0.00, starting frequency-maximum frequency(Hz)	0.00
	A023	Multi-speed3	0.00, starting frequency-maximum frequency(Hz)	0.00
	A024	Multi-speed4	0.00, starting frequency-maximum frequency(Hz)	0.00
	A025	Multi-speed5	0.00, starting frequency-maximum frequency(Hz)	0.00
	A026	Multi-speed6	0.00, starting frequency-maximum frequency(Hz)	0.00
	A027	Multi-speed7	0.00, starting frequency-maximum frequency(Hz)	0.00
	A028	Multi-speed8	0.00, starting frequency-maximum frequency(Hz)	0.00
	A029	Multi-speed9	0.00, starting frequency-maximum frequency(Hz)	0.00
	A030	Multi-speed10	0.00, starting frequency-maximum frequency(Hz)	0.00
	A031	Multi-speed11	0.00, starting frequency-maximum frequency(Hz)	0.00
	A032	Multi-speed12	0.00, starting frequency-maximum frequency(Hz)	0.00
	A033	Multi-speed13	0.00, starting frequency-maximum frequency(Hz)	0.00
	A034	Multi-speed14	0.00, starting frequency-maximum frequency(Hz)	0.00
A035	Multi-speed15	0.00, starting frequency-maximum frequency(Hz)	0.00	
A038	Jogging frequency	0.00, starting frequency-9.99(Hz)	1.00	
A039	Jogging selection	00(free-run on JG stop / invalid on running) / 01(stop decelerating on JG stop / invalid on running) / 02(DC braking on JG stop/invalid on running) / 03(free-run on JG stop/valid on running[JG after stop decelerating]) / 04 (stop decelerating on JG stop/valid on running) / 05 (DC braking on JG stop/valid on operating)	00	
V/f characteristic	A041	Torque boost selection	00 (manual torque boost) / 01 (automatic torque boost)	00
	A241	Torque boost selection, 2 nd motor	00 (manual torque boost) / 01 (automatic torque boost)	00
	A042	Manual torque boost	0.0-20.0(%)	1.0
	A242	Manual torque boost, 2 nd motor	0.0-20.0(%)	1.0
	A342	Manual torque boost, 3 rd motor	0.0-20.0(%)	1.0
	A043	Manual torque boost point	0.0-50.0(%)	5.0
	A243	Manual torque boost point, 2 nd motor	0.0-50.0(%)	5.0
	A343	Manual torque boost point, 3 rd motor	0.0-50.0(%)	5.0
	A044	1 st control	00/(VC)/01(VP1.7power)/02(free V/f setting)/03(SLV)/ 04(0Hz-SLV)/05(V2)	00
	A244	2 nd control	00/(VC)/01(VP1.7power)/02(free V/f setting) /03(SLV)/04(0Hz-SLV)	00
A344	3 rd control	00/(VC)/01(VP1.7power)	00	
A045	Output voltage gain	20. - 100.	100.	
Direct current braking	A051	DC braking selection	00(invalid)/01(valid)	00
	A052	DC braking frequency	0.00-60.00(Hz)	0.50
	A053	DC braking wait time	0.0 - 5.0(s)	0.0
	A054	DC braking power	0. - 100. (%) <0.-80.(%)>	0.
	A055	DC braking time	0.0 - 60.0(s)	0.0
	A056	DC braking edge/level selection	00(edge action)/01(level action)	01
	A057	DC braking power (starting time)	0. - 100. (%) <0.-80.(%)>	0.
	A058	DC braking time(starting time)	0.00-60.0(s)	0.0
	A059	DC carrier frequency	0.5-15(kHz) Derating <0.5-10kHz>	5.0<3.0>

(Note) < > indicate the setting range of 75 to 150kW

Function Mode

	Code	Function name	SJ300 Setting range	Initial data -FE/-FU/-F	Note	
Upper and lower limiter, jump frequency	A061	1 st frequency maximum limiter	0.00, 1 st frequency lower limiter - maximum frequency(Hz)	0.00		
	A261	2 nd frequency maximum limiter	0.00, 2 nd frequency lower limiter-2 nd setting maximum frequency(Hz)	0.00		
	A062	1 st frequency minimum limiter	0.00, start frequency-maximum frequency(Hz)	0.00		
	A262	2 nd frequency minimum limiter	0.00, start frequency-2 nd setting maximum frequency(Hz)	0.00		
	A063	Jump frequency1	0.00-99.99/100.0-400.0(Hz)	0.00		
	A064	Jump frequency Width 1	0.00-10.00(Hz)	0.50		
	A065	Jump frequency2	0.00-99.99/100.0-400.0(Hz)	0.00		
	A066	Jump frequency Width 2	0.00-10.00(Hz)	0.50		
	A067	Jump frequency3	0.00-99.99/100.0-400.0(Hz)	0.00		
	A068	Jump frequency Width 3	0.00-10.00(Hz)	0.50		
PID control	A069	Acceleration stop frequency	0.00-99.99/100.0-400.0(Hz)	0.00		
	A070	Acceleration stop time	0.00-60.0(s)	0.0		
	A071	PID selection	00(invalid)/01(valid)	00		
	A072	PID-P gain	0.2-5.0	1.0		
	A073	PID-I gain	0.0-3600.(s)	1.0		
	A074	PID-D gain	0.00-100.0(s)	0.00		
	A075	PID scale	0.01-99.99(%)	1.00		
	A076	PID feedback selection	00(feedback : O)/01(feedback : 0)	00		
	AVR	A081	AVR selection	00(ON always)/01(OFF always)/02(OFF on decelerating)	00/00/02	
		A082	Motor voltage selection	200/215/220/230/240, 380/400/415/440/460/480	(230/400)/ (230/460)/ (200/400)	
Operation mode/ adjustable function	A085	Operation mode selection	00(normal operation)/01(energy-saving operation)/02(Fuzzy)	00		
	A086	Energy-saving response-accuracy adjustment	0.0-100.0	50.0		
	A092	Acceleration time2	0.01-99.99/100.0-999.9/1000.-3600.(s)	15.00		
	A292	Acceleration time2(2 nd motor)	0.01-99.99/100.0-999.9/1000.-3600.(s)	15.00		
	A392	Acceleration time2(3 rd motor)	0.01-99.99/100.0-999.9/1000.-3600.(s)	15.00		
	A093	Deceleration time2	0.01-99.99/100.0-999.9/1000.-3600.(s)	15.00		
	A293	Deceleration time2(2 nd motor)	0.01-99.99/100.0-999.9/1000.-3600.(s)	15.00		
	A393	Deceleration time2(3 rd motor)	0.01-99.99/100.0-999.9/1000.-3600.(s)	15.00		
	A094	2 nd stage adjustable selection	00(change with 2CH terminal)/01(change with setting)	00		
	A294	2 nd stage adjustable selection(2 nd motor)	00(change with 2CH terminal)/01(change with setting)	00		
	A095	2 nd acceleration frequency	0.00-99.99/100.0-400.0(Hz)	0.00		
	A295	2 nd acceleration frequency(2 nd motor)	0.00-99.99/100.0-400.0(Hz)	0.00		
	A096	2 nd deceleration frequency	0.00-99.99/100.0-400.0(Hz)	0.00		
	A296	2 nd deceleration frequency (2 nd motor)	0.00-99.99/100.0-400.0(Hz)	0.00		
A097	Acceleration pattern selection	00(straight line)/01(S-curve)/02(U-curve)/03(reverse U-curve)	00			
A098	Deceleration pattern selection	00(straight line)/01(S-curve)/02(U-curve)/03(reverse U-curve)	00			
External frequency adjustment	A101	O1 start	0.00-99.99/100.0-400.0(Hz)	0.00		
	A102	O1 end	0.00-99.99/100.0-400.0(Hz)	0.00		
	A103	O1 start rate	0.-100.(%)	20.		
	A104	O1 end rate	0.-100.(%)	100.		
	A105	O1 start selection	00(external start frequency)/01(0Hz)	01		
	A111	O2 start	-400.-100./-99.9-0.00-99.9/100.-400.(Hz)	0.00		
	A112	O2 end	-400.-100./-99.9-0.00-99.9/100.-400.(Hz)	0.00		
	A113	O2 start rate	-100. - 100. (%)	-100.		
Accel, Decel	A114	O2 end rate	-100. - 100. (%)	100.		
	A131	Acceleration curve constant	01(small swelling)-10(large swelling)	02		
Instantaneous power failure restart	A132	Deceleration curve constant	01(small swelling)-10(large swelling)	02		
	b001	Retry selection	00(trip)/01(0Hz start)/02(start after equal frequency)/03(trip after equaling frequency and deceleration stop)	00		
	b002	Allowable under-voltage power failure time	0.3-1.0(s)	1.0		
	b003	Retry wait time	0.3-100.(s)	1.0		
	b004	Instantaneous power failure/ under-voltage trip during stop	00(invalid)/01(valid)/02(invalid during stop and deceleration by stop command)	00		
	b005	Instantaneous power failure/ under-voltage retry time selection	00(16 times)/01(free)	00		
	b006	Open-phase selection	00(invalid)/01(valid)	00		
b007	Frequency setting to match	0.00-99.99/100.0-400.0(Hz)	0.00			

Function mode

Code	Function name	SJ300 Setting range	Initial data -FE/-FU/-F	Note
Electronic thermal	b012	Electronic thermal level	0.2*constant current-1.20*constant current(A)	Rated Current of inverter
	b212	Electronic thermal level (2 nd motor)	0.2*constant current-1.20*constant current(A)	Rated Current of Inverter
	b312	Electronic thermal level (3 rd motor)	0.2*constant current-1.20*constant current(A)	Rated current of inverter
	b013	1 st electronic thermal characteristic selection	00(reduced characteristic)/ 01(constant torque characteristic)/ 02(free setting)	01/01/00
	b213	2 nd electronic thermal characteristic selection	00(reduced characteristic)/ 01(constant torque characteristic)/ 02(free setting)	01/01/00
	b313	3 rd electronic thermal characteristic selection	00/(reduced characteristic)/01(constant torque characteristic)/ 02(free setting)	01/01/00
	b015	Free electronic thermal frequency 1	0.-400.(Hz)	0.
	b016	Free electronic thermal current 1	0.0-1000.(A)	0.0
	b017	Free electronic thermal frequency 2	0.-400.(Hz)	0.
	b018	Free electronic thermal current 2	0.0-1000. (A)	0.0
	b019	Free electronic thermal frequency 3	0.-400.(Hz)	0.
b020	Free electronic thermal current 3	0.0-1000.(A)	0.0	
Overload limit	b021	Overload restriction selection	00(invalid)/01(enabled on acceleration / constant speed)/ 02(enabled on constant speed)/03(enabled on acceleration / constant speed (speed increasing at regenerating mode))	01
	b022	Overload restriction level	0.50* rated current-2.00* rated current(A) <-1.80*ratede current(A)>	Rated current of inverter x 1.50
	b023	Overload restriction limit constant	0.10-30.00(s)	1.00
	b024	Overload restriction 2 selection	00(invalid)/01(enabled on acceleration / constant speed)/ 02(enabled on constant speed)/03(enabled on acceleration / constant speed (speed increasing at regenerating mode))	01
	b025	Overload restriction level 2	0.50*rated current-2.00*rated current(A) <-1.80*rated current(A)>	Rated current of inverter x1.50
	b026	Overload restriction constant 2	0.10-30.00(s)	1.00
	b031	Software lock mode selection	00(impossible to change the data except this item when SFT terminal is ON)/01(impossible to change the data except setting frequency item when SFT terminal is ON)/02(impossible to change the data except this item)/ 03(impossible to change the data except setting frequency item)/ 10(possible to change data on operating)	01
Free V/f setting	b100	Free V/f frequency 1	0.- Free V/f frequency2(Hz)	0.
	b101	Free V/f voltage 1	0.-800.0(V)	0.0
	b102	Free V/f frequency 2	0.- Free V/f frequency3(Hz)	0.
	b103	Free V/f voltage 2	0.-800.0(V)	0.0
	b104	Free V/f frequency 3	0.- Free V/f frequency4(Hz)	0.
	b105	Free V/f voltage 3	0.-800.0(V)	0.0
	b106	Free V/f frequency 4	0.- Free V/f frequency5(Hz)	0.
	b107	Free V/f voltage 4	0.-800.0(V)	0.0
	b108	Free V/f frequency 5	0.- Free V/f frequency6(Hz)	0.
	b109	Free V/f voltage 5	0.-800.0(V)	0.0
	b110	Free V/f frequency 6	0.- Free V/f frequency7(Hz)	0.
	b111	Free V/f voltage 6	0.-800.0(V)	0.0
	b112	Free V/f frequency 7	0.-400.(Hz)	0.
b113	Free V/f voltage 7	0.-800.0(V)	0.0	
Intelligent input terminal setting	C001	Intelligent input 1 setting	01/(RV:Reverse is valid)/02(CF1:Multi-speed1)/03(CF2:Multi-speed2)/ 04(CF3:Multi-speed3)/ 05(CF4:Multi-speed4)/ 06(JG:Jogging)/ 07(DB:External DC braking)/ 08(SET:2 nd control)/ 09(2CH:two-stage adjustable speed)/ 11(FRS:Free-run)/ 12(EXT:External trip)/ 13(USP:Unattended start protection)/ 14(CS:commercial change)/ 15(SFT:software lock)/ 16(AT:Analog input voltage/current select)/ 17(SET3:3 rd control)/ 18(RS:Reset inverter)/ 20(STA:3wire run)/ 21(STP:3wire keep)/ 22(F/R:3wire forward/reverse)/ 23(PID:PID selection valid/invalid)/ 24(PIDC:PID integrating reset)/ 26(CAS:Control gain switch function)/ 27(UP:Remote control UP function)/ 28(DWN:Remote control DOWN function)/29(UDC:Remote control data clear)/ 31(OPE:Operating by operator select)/ 32(SF1:Multi-speed bit1)/ 33(SF2:Multi-speed bit2)/ 34(SF3:Multi-speed bit3)/ 35(SF4:Multi-speed bit4)/ 36(SF5:Multi speed bit5)/ 37(SF6:Multi-speed bit6)/ 38(SF7:Multi-speed bit7)/ 39(OLR:Overload restriction change) / 40(TL:Torque limit select)/ 41(TRQ1:Torque limit switch 1)/ 42(TRQ2:Torque limit switch 2)/ 43((PPI:P/PI switch)/ 44(BOK:Braking comformation)/ 45(ORT:Orientation)/ 46(LAC:LAD cancel)/ 47(PCLR:Position error clear)/ 48(STAT:Permission of pulse train)/ no(NO:No assign)	18
	C002	Intelligent input 2 setting		16
	C003	Intelligent input 3 setting		06
	C004	Intelligent input 4 setting		11
	C005	Intelligent input 5 setting		09
	C006	Intelligent input 6 setting		03/13/03
	C007	Intelligent input 7 setting		02
	C008	Intelligent input 8 setting		01

(Note) < > indicate the setting range of 75 to 150kW

Function mode

	Code	Function name	SJ300 Setting range	Initial data -FE/-FU/-F	Note
Input terminal setting Intelligent	C011	Intelligent input 1 a/b (NO/NC) selection	00(NO)/01(NC)	00	
	C012	Intelligent input 2 a/b (NO/NC) selection	00(NO)/01(NC)	00	
	C013	Intelligent input 3 a/b (NO/NC) selection	00(NO)/01(NC)	00	
	C014	Intelligent input 4 a/b (NO/NC) selection	00(NO)/01(NC)	00	
	C015	Intelligent input 5 a/b (NO/NC) selection	00(NO)/01(NC)	00	
	C016	Intelligent input 6 a/b (NO/NC) selection	00(NO)/01(NC)	00/01/00	
	C017	Intelligent input 7a/b (NO/NC) selection	00(NO)/01(NC)	00	
	C018	Intelligent input 8 a/b (NO/NC) selection	00(NO)/01(NC)	00	
	C019	Input FW a/b(NO/NC) Selection	00(NO)/01(NC)	00	
Intelligent output terminal setting	C021	Intelligent output 11 setting	00(RUN:running)/01(FA1:Frequency arrival type1 signal)/02(FA2:over setting frequency)/03(OL:Overload advance notice signal)/04(OD:Output deviation for PID control)/05(AL:Alarm signal)/06(FA3:Only setting frequency)/07(OTQ:Over-torque signal)/08(IP:On instantaneous stop)/09(UV:Under voltage)/10(TRQ:Torque limit)/11(RNT:RUN time over/12(ONT:ON time over)/13(THM:thermal caution)/19(BRK:Brake release signal)/20(BER:Brake error signal)/21(ZS:Zero speed detect signal)/22(DSE:Speed error over signal)/23(POK:Positioning completion signal)24(FA4:Over frequency 2 signal)/25(FA5:Only setting frequency)/26(OL2: Overload advance notice signal 2)	01	
	C022	Intelligent output 12 setting	(Intelligent output terminal 11-13 or 11-14 becomes AC0-AC2 or AC0-AC3 (Can:Alarm cord output) forcibly when alarm cord output is selected in C062)	00	
	C023	Intelligent output 13 setting		03	
	C024	Intelligent output 14 setting		07	
	C025	Intelligent output 15 setting		08	
	C026	Alarm relay output		05	
	C027	FM selection	00(Output frequency)/01(Output current) /02(Output torque)/03(Digital output frequency)/04(Output voltage)/05(Input electric power)/06(thermal load rate)/07(LAD frequency)	00	
	C028	AM selection	00(Output frequency)/01(Output current)/02(Output torque)/04(Output voltage)/05(Input electric power)/06(thermal load rate)/07(LAD frequency)	00	
	C029	AMI selection	00(Output frequency)/01(Output current)/02(Output torque)/04(Output voltage)/05(Input electric power)/06(Thermal load rate)/07(LAD frequency)	00	
state terminal setting Output setting,Output level setting	C031	Intelligent output 11 a/b	00(NO)/01(NC)	00	
	C032	Intelligent output 12 a/b	00(NO)/01(NC)	00	
	C033	Intelligent output 13 a/b	00(NO)/01(NC)	00	
	C034	Intelligent output 14 a/b	00(NO)/01(NC)	00	
	C035	Intelligent output 15 a/b	00(NO)/01(NC)	00	
	C036	Alarm relay output a/b	00(NO)/01(NC)	01	
	C040	Overload advance notice signal output mode	00(On accel. And decel. constant speed)/01(Only constant speed)	01	
	C041	Overload advance notice level	0.0-2.0*rated current(A)	Inverter rated current	
	C042	Frequency arrival setting for acceleration.	0.00-99.99/100.0-400.0(Hz)	0.00	
	C043	Arrival frequency setting for deceleration.	0.00-99.99/100.0-400.0(Hz)	0.00	
	C044	PID deviation setting level	0.0-100.0(%)	3.0	
	C045	Frequency arrival setting for acceleration 2.	0.00-99.99/100.0-400.0(Hz)	0.00	
	C046	Arrival frequency setting for deceleration 2	0.00-99.99/100.0-400.0(Hz)	0.00	
	C055	Over torque level setting (Forward-driving)	0.-200.(%) <0.-180.>	100.	
	C056	Over torque level setting (Reverse-regenerating)	0.-200.(%)	100.	
C057	Over torque level setting (Reverse-driving)	0.-200.(%) <0.-180.>	100.		
C058	Over torque level setting (Forward-regenerating)	0.-200.(%) <0.-180.>	100.		
C061	Thermal warning level setting	0.-100.(%) <0.-180.>	80.		
C062	Alarm code selection	00(Invalid)/01(3bit)/02(4bit)	00		
C063	Zero speed detection level setting	0.00-99.99/100.(Hz)	0.00		
Communication function adjustment	C070	Data command	02(operator)/03(RS485)/04(option1)/05(option2)	02	
	C071	Communicating transmission speed	02(loop-back test)03(2400bps)/04(4800bps)/05(9600bps)/06(19200bps)	04	
	C072	Communication code	1.-32.	1.	
	C073	Communication bit	7(7bit)/8(8bit)	7	
	C074	Communication parity	00(no parity name)/01(even parity)/02(odd parity)	00	
	C075	Communication stop bit	1(bit)/2(bit)	1	
C078	Communication waiting time	0.-1000.(ms)	0.		
Analog meter setting	C081	O adjustment	0.-9999./1000-6553(10000-65530)	Setting on forwarding	
	C082	OI adjustment	0.-9999./1000-6553(10000-65530)	Setting on forwarding	
	C083	O2 adjustment	0.-9999./1000-6553(10000-65530)	Setting on forwarding	
	C085	Thermistor adjustment	0.0 - 1000.	105.0	
	C086	AM offset adjustment	0.0 - 10.0(V)	0.0	
	C087	AMI adjustment	0. - 255.	80	
	C088	AMI offset adjustment	0. - 20.0(mA)	4.0	

(Note) < > indicate the setting range of 75 to 150kW

Function mode

Code	Function name	SJ300 Setting range	Initial data -FE/-FU/-F	Note
b034	RUN time/Power ON time level	0.-9999./1000-6553(10000-65530)hr	0.	
b035	Operation direction restrict	00(Reverse is valid)/01(Only forward)/02(Only reverse)	00	
b036	Start reduced voltage	00(Start reduced voltage time small)-06(Start reduced voltage time large)	06	
b037	Display selection	00(all display)/01(each function display)/02(User setting / main setting)	00	
b040	Torque limit mode selection	00(4 quadrant mode)/01(Terminal operation)/ 02(Analog input)/03(Option1)/04(Option2)	00	
b041	Torque limit level 1 setting (Forward-driving at 4 quadrant mode)	0.-200.(%)/no(Invalid) <0.-180.(%)/no(Invalid)>	150.	
b042	Torque limit level 2 setting (Reverse-regenerating at 4 quadrant mode)	0.-200.(%)/no(Invalid) <0.-180.(%)/no(Invalid)>	150.	
b043	Torque limit level 3 setting (Reverse-driving at 4 quadrant mode)	0.-200.(%)/no(Invalid) <0.-180.(%)/no(Invalid)>	150.	
b044	Torque limit level 4 setting (Forward-regenerating at 4 quadrant mode)	0.-200.(%)/no(Invalid) <0.-180.(%)/no(Invalid)>	150.	
b045	Torque LAD-STOP selection	00(Invalid)/01(Valid)	00	
b046	Reverse run prevention selection	00(Invalid)/01(Valid)	00	
b050	Selection of non-stop function at instantaneous power failure	00(Invalid)/01(Valid)	00	
b051	Start voltage of non-stop function setting	0.0-1000.(V)	0.0	
b052	OV LAD-STOP level of non- stop function setting	0.0-1000.(V)	0.0	
b053	Deceleration time of non- stop function setting	0.01-99.99/100.0-999.9/1000.-3600.(s)	1.00	
b054	Deceleration frequency width of non-stop function setting	0.00-10.00(Hz)	0.00	
b080	AM adjustment	0. - 255.	180	
b081	FM adjustment	0. - 255.	60	
b082	Start frequency adjustment	0.10-9.99(Hz)	0.50	
b083	Carrier frequency setting	0.5-15.0(kHz) Derating enable, <0-10kHz>	5.0 <3.0>	
b084	Initialize mode	00(Trip history clear)/01(Data initialization)/ 02(Trip history clear + data initialization)	00	
b085	Country code for initialization	00(Interior)/01(EC)/02(USA)	01/02/00	
b086	Frequency scalar conversion factor	0.1-99.9	1.0	
b087	STOP key enable	00(valid)/01(Invalid)	00	
b088	Resume on FRS cancellation mode	00(0Hz start)/01(Start f-equaling)	00	
b090	BRD usage ratio	0.0-100.0(%)	0.0	
b091	Stop mode selection	00(deceleration stop)/01(Free-run stop)	00	
b092	Cooling fan control	00(Always ON)/ 01(ON during run, After power ON, then for 5 minutes on stop is implied.)	00	
b095	BRD selection	00(Invalid)/01(valid<Invalid during stop>)/02(valid<valid during stop>)	00	
b096	BRD ON level	330-380/660-760(V)	360/720	
b098	Thermistor selection	00(Invalid)/01(Positive temperature coefficient enable)/02 (NTC enable)	00	
b099	Thermistor error level	0. - 9999. (ohm)	3000.	
b120	Braking control selection	00(Invalid)/01(valid)	00	
b121	Waiting time for releasing braking conformation	0.00-5.00(s)	0.00	
b122	Waiting time for acceleration	0.00-5.00(s)	0.00	
b123	Waiting time for stop	0.00-5.00(s)	0.00	
b124	Waiting time for signal conformation	0.00-5.00(s)	0.00	
b125	Releasing frequency	0.00-99.99/100.0-400.0(Hz)	0.00	
b126	Releasing current	0.00*rated current-2.00*rated current(A)	Rated current of inverter	
C091	Debug mode selection	00(No display)/01(Display)	00	
C101	UP/DWN selection	00(No frequency data)/01(Keep frequency data)	00	
C102	Reset selection	00(Trip cancel during ON)/01(Trip cancel during OFF)/ 02(Valid only during trip<Cancel during ON>)	00	
C103	Reset f frequency matching selection	00(0Hz start)/01(Start f-equaling)	00	
C111	Overload advance notice level	0.0-2.0*rated current(A)	Inverter rated current	
C121	O zero adjustment	0.-9999./1000-6553(10000-65530)	Set on forwarding	
C122	OI zero adjustment	0.-9999./1000-6553(10000-65530)	Set on forwarding	
C123	O2 zero adjustment	0.-9999./1000-6553(10000-65530)	Set on forwarding	

(Note) < > indicate the setting range of 75 to 150kW

Function mode

Code	Function name	SJ300 Setting range	Initial data -FE/-FU/-F	Note
H001	Autotuning selection	00(Invalid)/01(Valid(the motor does not rotate))/ 02(Valid(the motor rotates))	00	
H002	1 st motor constant selection	00(Hitachi general purpose motor data)/01(Autotuning data) / 02(Autotuning data with online autotuning)	00	
H202	2 nd motor constant selection	00(Hitachi general purpose motor data)/01(Autotuning data) / 02(Autotuning data with online autotuning)	00	
H003	1 st allowable motor selection	0.20-75.0(kW) <0.2-160(kW)>	Set on forwarding	
H203	2 nd allowable motor selection	0.20-75.0(kW) <0.2-160(kW)>	Set on forwarding	
H004	1 st motor pole selection	2/4/6/8(pole)	4	
H204	2 nd motor pole selection	2/4/6/8(pole)	4	
H005	1 st speed response setting	0.001-9.999/10.00-65.53	1.590	
H205	2 nd speed response setting	0.001-9.999/10.00-65.53	1.590	
H006	1 st stabilized factor	0. - 255.	100.	
H206	2 nd stabilized factor	0. - 255.	100.	
H306	3 rd stabilized factor	0. - 255.	100.	
H020	1 st motor constant R1	0.000-9.999/10.00-65.53(ohm)	Set on forwarding	
H220	2 nd motor constant R1	0.000-9.999/10.00-65.53(ohm)	Set on forwarding	
H021	1 st motor constant R2	0.000-9.999/10.00-65.53(ohm)	Set on forwarding	
H221	2 nd motor constant R2	0.000-9.999/10.00-65.53(ohm)	Set on forwarding	
H022	1 st motor constant L	0.00-99.99/100.0-655.3(mH)	Set on forwarding	
H222	2 nd motor constant L	0.00-99.99/100.0-655.3(mH)	Set on forwarding	
H023	1 st motor constant I _o	0.00-99.99/100.0-655.3(A)	Set on forwarding	
H223	2 nd motor constant I _o	0.00-99.99/100.0-655.3(A)	Set on forwarding	
H024	1 st motor constant J	0.001-9.999/10.00-99.99/100.0-9999.(kgm ²)	Set on forwarding	
H224	2 nd motor constant J	0.001-9.999/10.00-99.99/100.0-9999.(kgm ²)	Set on forwarding	
H030	1 st motor constant R1 (Autotuning data)	0.000-9.999/10.00-65.53(ohm)	Set on forwarding	
H230	2 nd motor constant R1 (Autotuning data)	0.000-9.999/10.00-65.53(ohm)	Set on forwarding	
H031	1 st motor constant R2 (Autotuning data)	0.000-9.999/10.00-65.53(ohm)	Set on forwarding	
H231	2 nd motor constant R2 (Autotuning data)	0.000-9.999/10.00-65.53(ohm)	Set on forwarding	
H032	1 st motor constant L (Autotuning data)	0.00-99.99/100.0-655.3(mH)	Set on forwarding	
H232	2 nd motor constant L (Autotuning data)	0.00-99.99/100.0-655.3(mH)	Set on forwarding	
H033	1 st motor constant I _o (Autotuning data)	0.00-99.99/100.0-655.3(A)	Set on forwarding	
H233	2 nd motor constant I _o (Autotuning data)	0.00-99.99/100.0-655.3(A)	Set on forwarding	
H034	1 st motor constant J	0.001-9.999/10.00-99.99/100.0-9999.(kgm ²)	Set on forwarding	
H234	2 nd motor constant J	0.001-9.999/10.00-99.99/100.0-9999.(kgm ²)	Set on forwarding	
H050	1 st PI-control proportion gain setting	0.00-99.99/100.0-999.9/1000.(%)	100.0	
H250	2 nd PI-control proportion gain setting	0.00-99.99/100.0-999.9/1000.(%)	100.0	
H051	1 st PI-control integration gain setting	0.00-99.99/100.0-999.9/1000.(%)	100.0	
H251	2 nd PI-control integration gain setting	0.00-99.99/100.0-999.9/1000.(%)	100.0	
H052	1 st P-control proportion gain setting	0.01-10.00	1.00	
H252	2 nd P-control proportion gain setting	0.01-10.00	1.00	
H060	1 st 0Hz-SLV limiter setting	0.-100.(%)	100.	
H260	2 nd 0Hz-SLV limiter setting	0.-100.(%)	100.	
H070	PI-control proportion gain for switching	0.00-99.99/100.0-999.9/1000.(%)	100.0	
H071	PI-control integration gain for switching	0.00-99.99/100.0-999.9/1000.(%)	100.0	
H072	P-control proportion gain for switching	0.00-10.00	1.00	

(Note) < > indicate the setting range of 75 to 150kW

Function mode

Code	Function name	SJ300 Setting range	Initial data -FE/-FU/-F	Note	
Option	P001	Option1 operation selection on error	00(TRP)/01(RUN)	00	
	P002	Option2 operation selection on error	00(TRP)/01(RUN)	00	
	P010	Feed-back option selection	00(Invalid)/01(Valid)	00	
	P011	Encoder pulse number setting	128.-9999./1000-6500(10000-65000) (pulse)	1024	
	P012	Control mode selection	00(ASR mode)/01(APR mode)	00	
	P013	Pulse train input mode selection	00(Mode 0)/01(Mode 1)/02(Mode 2)/03(Mode 3)	00	
	P014	Orientation stop position setting	0.-4095.	0.	
	P015	Orientation speed setting	0.00-99.99/100.0-120.0(Hz)	5.00	
	P016	Orientation direction selection	00(Forward)/01(Reverse)	00	
	P017	Orientation completion range setting	0.-9999./1000(10000) (pulse)	5	
	P018	Orientation completion delay time setting	0.00-9.99(s)	0.00	
	P019	Electronic gear position selection	00(Feedback)/01(Reference)	00	
	P020	Electronic gear numerator of ratio setting	0.-9999.	1.	
	P021	Electronic gear denominator of ratio setting	0.-9999.	1.	
	P022	Position control feed-forward gain setting	0.00-99.99/100.0-655.3	0.00	
	P023	Position control loop gain setting	0.00-99.99/100.0	0.50	
	P025	Compensation of secondary resistor selection	00(Invalid)/01(Valid)	00	
	P026	Over-speed detect level setting	0.00-99.99/100.0-150.0(%)	135.0	
	P027	Speed-error over detect level setting	0.00-99.99/100.0-120.0(Hz)	7.50	
	P031	Digital input option input mode selection (Acc/Dec)	00(operator)/01(option1)/02(option2)	00	
	P032	Stop position setting for orientation input mode selection	00(operator)/01(option1)/02(option2)	00	
	P044	DeviceNet running order of monitoring timer setting	0.00-99.99s	1.00	
	P045	Setting in action of abnormal communication	00(trip)/01(trip after deceleration stop)/02(Invalid)/03(free-run)04(deceleration stop)	0.	
	P046	Output assemble instance Number setting	20,21,100	21	
	P047	Input assemble instance Number setting	70,71,101	71	
	P048	Detect of idol mode for motion setting	00(trip)/01(trip after deceleration stop)/02(Invalid)/03(free-run)04(deceleration stop)	01	
	P049	Pole setting of rotation speed	0-38(even only)	0	
	User selection	U001	User1 selection	no/d001-P049 <-P032>	no
		U002	User2 selection	no/d001-P049 <-P032>	no
U003		User3 selection	no/d001-P049 <-P032>	no	
U004		User4 selection	no/d001-P049 <-P032>	no	
U005		User5 selection	no/d001-P049 <-P032>	no	
U006		User6 selection	no/d001-P049 <-P032>	no	
U007		User7 selection	no/d001-P049 <-P032>	no	
U008		User8 selection	no/d001-P049 <-P032>	no	
U009		User9 selection	no/d001-P049 <-P032>	no	
U010		User10 selection	no/d001-P049 <-P032>	no	
U011		User11 selection	no/d001-P049 <-P032>	no	
U012		User12 selection	no/d001-P049 <-P032>	no	

(Note 1) P044-P049 are displayed on a 0.4-55kW model.

1.2.2 L300P

Monitor code

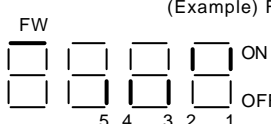
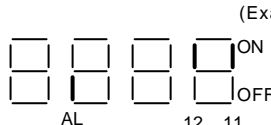
Display code	Function name	L300P monitor or data range (digital operator)	Initial data	Note
d001	Output frequency monitor	0.00-99.99/100.0-400.0(Hz)	-	
d002	Output current monitor	0.0-999.9(A)	-	
d003	Operation direction monitor	F(forward)/o(stop)/r(reverse)	-	
d004	PID feedback monitor	0.00-99.99/100.0-999.9/1000. -9999. / 1000-9999/ 100-999 (10000-99900)	-	
d005	Intelligent input terminal monitor	(Example) FW, terminal2, and 1: ON Terminal 5, 4, 3 :OFF 	-	
d006	Intelligent output terminal monitor	(Example) Terminal2, 1:ON AL :OFF 	-	
d007	Frequency conversion monitor	0.00-99.99/100.0-999.9/1000. -9999. / 1000-3996	-	
d013	Output voltage monitor	0.0-600.0 V	-	
d014	Electric power monitor	0.0-999.9 kW	-	
d016	Accumulated time monitor during RUN	0.-9999./1000-9999/ 100-999 h	-	
d017	Power ON time monitor	0.-9999./1000-9999/ 100-999 h	-	
d080	Number of trip time monitor	0.-9999./1000-6553(10000-65530) (time)	-	
d081	Trip monitor 1	Trip Code, frequency(Hz), current(A), voltage(V),RUN time(h) power ON time(h)	-	
d082	Trip monitor 2	Trip Code, frequency(Hz), current(A), voltage(V),RUN time(h) power ON time(h)	-	
d083	Trip monitor 3	Trip Code, frequency(Hz), current(A), voltage(V),RUN time(h) power ON time(h)	-	
d084	Trip monitor 4	Trip Code, frequency(Hz), current(A), voltage(V),RUN time(h) power ON time(h)	-	
d085	Trip monitor 5	Trip Code, frequency(Hz), current(A), voltage(V),RUN time(h) power ON time(h)	-	
d086	Trip monitor 6	Trip Code, frequency(Hz), current(A), voltage(V),RUN time(h) power ON time(h)	-	
d090	Warning monitor	Warning code	-	
F001	Output frequency setting	0.0, starting frequency-Max. frequency (2 nd max. frequency)(Hz)	0.00	
F002	1 st acceleration time	0.01-99.99/100.0-999.9/1000.-3600.(s)	30.00	
F202	2 nd acceleration time	0.01-99.99/100.0-999.9/1000.-3600. (s)	30.00	
F003	1 st deceleration time	0.01-99.99/100.0-999.9/1000.-3600. (s)	30.00	
F203	2 nd deceleration time	0.01-99.99/100.0-999.9/1000.-3600. (s)	30.00	
F004	Operation direction selection	00(forward)/01(reverse)	00	

(Note1) Change mode during run by selection of b031 (software lock selection).

(Note2) Do not forget to press "STR" key when you change the display.

Function Mode

Code	Function name	L300P Setting range	Initial data -FE/-FU/-FR	Note
Base setting	A001	Frequency setting selection	00(VR)/01(terminal)/02(operator)/03(RS485)/04(option1)/05(option2)	01/01/00
	A002	Operation setting selection	01(terminal)/02(operator)/03(RS485)/04(option1)/05(option2)	01/01/02
	A003	Base frequency	30. - Maximum. frequency(Hz)	50./60./60.
	A203	Base frequency, 2nd motor	30. - 2 nd Maximum. frequency (Hz)	50./60./60.
	A004	Maximum frequency	30. - 400. (Hz)	50./60./60.
	A204	Maximum frequency, 2nd motor	30. - 400. (Hz)	50./60./60.
Analog input setting	A005	AT terminal selection	00(Changing of O and OI with AT terminal)/01(Changing of O and O2 with AT terminal)	00
	A006	O2 selection	00(single)/01(auxiliary speed of O, OI) [no reversible] /02(auxiliary speed of O, OI [reversible]	00
	A011	O start	0.00-99.99/100.0-400.0 (Hz)	0.00
	A012	O end	0.00-99.99/100.0-400.0 (Hz)	0.00
	A013	O start rate	0. -100.0 (%)	0.
	A014	O end rate	0. -100.0(%)	100.
	A015	O start selection	00 (external starting frequency)/01(OHZ)	01
	A016	O, OI, O2 sampling	1.-30.(times)	8.
Multistage speed, jogging frequency setting	A019	Multi-speed selection	00(binary : range is to 16 stage speed with 4 terminals)/01(bit : range is to 6 stage speed with 5 terminals)	00
	A020	Multi-speed 0	0.00, starting frequency-maximum. frequency(Hz)	0.00
	A220	Multi-speed 0, 2 nd motor	0.00, starting frequency-2 nd maximum frequency(Hz)	0.00
	A021	Multi-speed1	0.00, starting frequency-maximum frequency(Hz)	0.00
	A022	Multi-speed2	0.00, starting frequency-maximum frequency(Hz)	0.00
	A023	Multi-speed3	0.00, starting frequency-maximum frequency(Hz)	0.00
	A024	Multi-speed4	0.00, starting frequency-maximum frequency(Hz)	0.00
	A025	Multi-speed5	0.00, starting frequency-maximum frequency(Hz)	0.00
	A026	Multi-speed6	0.00, starting frequency-maximum frequency(Hz)	0.00
	A027	Multi-speed7	0.00, starting frequency-maximum frequency(Hz)	0.00
	A028	Multi-speed8	0.00, starting frequency-maximum frequency(Hz)	0.00
	A029	Multi-speed9	0.00, starting frequency-maximum frequency(Hz)	0.00
	A030	Multi-speed10	0.00, starting frequency-maximum frequency(Hz)	0.00
	A031	Multi-speed11	0.00, starting frequency-maximum frequency(Hz)	0.00
	A032	Multi-speed12	0.00, starting frequency-maximum frequency(Hz)	0.00
	A033	Multi-speed13	0.00, starting frequency-maximum frequency(Hz)	0.00
	A034	Multi-speed14	0.00, starting frequency-maximum frequency(Hz)	0.00
A035	Multi-speed15	0.00, starting frequency-maximum frequency(Hz)	0.00	
A038	Jogging frequency	0.00, starting frequency-9.99(Hz)	1.00	
A039	Jogging selection	00(free-run on JG stop / invalid on running) / 01(stop decelerating on JG stop / invalid on running) / 02(DC braking on JG stop/invalid on running) / 03(free-run on JG stop/valid on running[JG after stop decelerating]) / 04 (stop decelerating on JG stop/valid on running) / 05 (DC braking on JG stop/valid on operating)	00	
V/f characteristic	A041	Torque boost selection	00 (manual torque boost) / 01 (automatic torque boost)	00
	A241	Torque boost selection, 2 nd motor	00 (manual torque boost) / 01 (automatic torque boost)	00
	A042	Manual torque boost	0.0-20.0(%)	1.0
	A242	Manual torque boost, 2 nd motor	0.0-20.0(%)	1.0
	A043	Manual torque boost point	0.0-50.0(%)	5.0
	A243	Manual torque boost point, 2 nd motor	0.0-50.0(%)	5.0
	A044	1 st control	00/(VC)/01(VP1.7power)/02(free V/f setting)	00
	A244	2 nd control	00/(VC)/01(VP1.7power)/02(free V/f setting)	00
A045	Output voltage gain	20. - 100. (%)	100.	
Direct current braking	A051	DC braking selection	00(Invalid)/01(valid)	00
	A052	DC braking frequency	0.00-60.00(Hz)	0.50
	A053	DC braking wait time	0.0 - 5.0(s)	0.0
	A054	DC braking power	0. - 70. (%)	0.
	A055	DC braking time	0.0 - 60.0(s)	0.0
	A056	DC braking edge/level selection	00(edge action)/01(level action)	01
	A057	DC braking power (starting time)	0. - 70. (%)	0.
	A058	DC braking time (starting time)	0.00-60.0(s)	0.0
A059	DC carrier frequency	0.5-12(kHz) Derating <0.5-8(kHz)>	3.0	

(Note) < > indicate the setting range of 90 to 132kW

Function Mode

	Code	Function name	L300P Setting range	Initial data -FE/-FU/-FR	Note
Upper and lower limiter /jump frequency	A061	1 st frequency upper limiter	0.00, 1 st frequency lower limiter-maximum frequency(Hz)	0.00	
	A261	2 nd frequency upper limiter	0.00, 2 nd frequency lower limiter-2 nd setting maximum frequency(Hz)	0.00	
	A062	1 st frequency lower limiter	0.00, start frequency-maximum frequency(Hz)	0.00	
	A262	2 nd frequency lowerlimiter	0.00, start frequency-2 nd setting maximum frequency(Hz)	0.00	
	A063	Jump frequency1	0.00-99.99/100.0-400.0(Hz)	0.00	
	A064	Jump frequency Width 1	0.00-10.00(Hz)	0.50	
	A065	Jump frequency2	0.00-99.99/100.0-400.0(Hz)	0.00	
	A066	Jump frequency Width 2	0.00-10.00(Hz)	0.50	
	A067	Jump frequency3	0.00-99.99/100.0-400.0(Hz)	0.00	
	A068	Jump frequency Width 3	0.00-10.00(Hz)	0.50	
PID control	A069	Acceleration stop frequency	0.00-99.99/100.0-400.0(Hz)	0.00	
	A070	Acceleration stop time	0.00-60.0(s)	0.0	
	A071	PID selection	00(invalid)/01(valid)	00	
	A072	PID-P gain	0.2-5.0	1.0	
	A073	PID-I gain	0.0-3600.(s)	1.0	
	A074	PID-D gain	0.00-100.0(s)	0.00	
AVR	A075	PID scale	0.01-99.99	1.00	
	A076	PID feedback selection	00(feedback : OI)/01(feedback : O)	00	
AVR	A081	AVR selection	00(ON always)/01(OFF always)/02(OFF on decelerating)	00/00/02	
	A082	Motor voltage selection	200/215/220/230/240, 380/400/415/440/460/480	(230/400) (230/460) (200/400)	
Operation mode/ adjustable function	A085	Operation mode selection	00(normal operation)/01(energy-saving operation)	00	
	A086	Energy-saving response-accuracy adjustment	0.0-100.0	50.0	
	A092	Acceleration time2	0.01-99.99/100.0-999.9/1000.-3600.(s)	15.00	
	A292	2 nd acceleration time2	0.01-99.99/100.0-999.9/1000.-3600.(s)	15.00	
	A093	Deceleration time2	0.01-99.99/100.0-999.9/1000.-3600.(s)	15.00	
	A293	2 nd deceleration time2	0.01-99.99/100.0-999.9/1000.-3600.(s)	15.00	
	A094	2 nd stage adjustable selection	00(change with 2CH terminal)/01(change with setting)	00	
	A294	2 nd stage adjustable selection(2 nd motor)	00(change with 2CH terminal)/01(change with setting)	00	
	A095	2 nd acceleration frequency	0.00-99.99/100.0-400.0(Hz)	0.00	
	A295	2 nd acceleration frequency(2 nd motor)	0.00-99.99/100.0-400.0(Hz)	0.00	
	A096	2 nd deceleration frequency	0.00-99.99/100.0-400.0(Hz)	0.00	
	A296	2 nd deceleration frequency (2 nd motor)	0.00-99.99/100.0-400.0(Hz)	0.00	
External frequency adjustment	A097	Acceleration pattern selection	00(straight line)/01(S-curve)/02(U-curve)/03(reverse U-curve)	00	
	A098	Deceleration pattern selection	00(straight line)/01(S-curve)/02(U-curve)/03(reverse U-curve)	00	
	A101	OI start	0.00-99.99/100.0-400.0(Hz)	0.00	
	A102	OI end	0.00-99.99/100.0-400.0(Hz)	0.00	
	A103	OI start rate	0.-100.(%)	20.	
	A104	OI end rate	0.-100.(%)	100.	
	A105	OI start selection	00(external start frequency)/01(0Hz)	01	
	A111	O2 start	-400.--100./-99.9-0.00-99.9/100.-400.(Hz)	0.00	
	A112	O2 end	-400.--100./-99.9-0.00-99.9/100.-400.(Hz)	0.00	
	A113	O2 start rate	-100.- 100.(%)	-100.	
Accel/Decel	A114	O2 end rate	-100.- 100.(%)	100.	
	A131	Acceleration curve constant	01(small swelling)-10(large swelling)	02	
Instantaneous power failure restart	A132	Deceleration curve constant	01(small swelling)-10(large swelling)	02	
	b001	Retry selection	00(trip)/01(0Hz start)/02(start after equal frequency)/03(trip after equaling frequency and deceleration stop)	00	
	b002	Allowable under-voltage power failure time	0.3-1.0(s)	1.0	
	b003	Retry wait time	0.3-100.(s)	1.0	
	b004	Instantaneous power-failure/under-voltage trip during stop	00(invalid)/01(valid)/02(invalid during stop and deceleration by stop command)	00	
	b005	Instantaneous power-failure/under-voltage retry time selection	00(16 times)/01(free)	00	
	b006	Open-phase selection	00(invalid)/01(valid)	00	
Electronic thermal	b007	Frequency setting to match	0.00-99.99/100.0-400.0(Hz)	0.00	
	b012	Electronic thermal level	0.2*constant current-1.20*constant current(A)	Rated Current of inverter	
	b212	Electronic thermal level (2 nd motor)	0.2*constant current-1.20*constant current(A)	Rated Current of inverter	
	b013	Electronic thermal characteristic selection	00/(reduced characteristic)/01(constant torque characteristic)/02(free setting)	01/01/00	
	b213	Electronic thermal characteristic selection (2 nd motor)	00/(reduced characteristic)/01(constant torque characteristic)/02(free setting)	01/01/00	
	b015	Free electronic thermal frequency 1	0.-400.(Hz)	0.	
	b016	Free electronic thermal current 1	0.0-1000.(A)	0.0	
	b017	Free electronic thermal frequency 2	0.-400.(Hz)	0.	
	b018	Free electronic thermal current 2	0.0-1000.(A)	0.0	
	b019	Free electronic thermal frequency 3	0.-400.(Hz)	0.	
b020	Free electronic thermal current 3	0.0-1000.(A)	0.0		

Function Mode

Code	Function name	L300P Setting range	Initial data -FE/-FU/-FR	Note	
Overload limit	b021	Overload restriction selection	00(Invalid)/01(enabled on acceleration / constant speed)/02(enabled on constant speed)	01	
	b022	Overload restriction level	0.50* rated current-1.50* rated current(A)	Rated current of inverter x 1.20	
	b023	Overload restriction limit constant	0.10-30.00(s)	1.00	
	b024	Overload restriction 2 selection	00(Invalid)/01(valid on acceleration / constant speed)/02(valid on constant speed)	01	
	b025	Overload restriction level 2	0.50*rated current-1.50*rated current(A)	Rated current of inverter x1.20	
	b026	Overload restriction constant 2	0.10-30.00(s)	1.00	
Lock	b031	Software lock mode selection	00(impossible to change the data except this item when SFT terminal is ON)/01(impossible to change the data except setting frequency item when SFT terminal is ON)/02(impossible to change the data except this item)/03(impossible to change the data except setting frequency item)/10(possible to change data on operating)	01	
Free V/f setting	b100	Free V/f frequency 1	0.- Free V/f frequency2(Hz)	0.	
	b101	Free V/f voltage 1	0.-800.0(V)	0.0	
	b102	Free V/f frequency 2	0.- Free V/f frequency3(Hz)	0.	
	b103	Free V/f voltage 2	0.-800.0(V)	0.0	
	b104	Free V/f frequency 3	0.- Free V/f frequency4(Hz)	0.	
	b105	Free V/f voltage 3	0.-800.0(V)	0.0	
	b106	Free V/f frequency 4	0.- Free V/f frequency5(Hz)	0.	
	b107	Free V/f voltage 4	0.-800.0(V)	0.0	
	b108	Free V/f frequency 5	0.- Free V/f frequency6(Hz)	0.	
	b109	Free V/f voltage 5	0.-800.0(V)	0.0	
	b110	Free V/f frequency 6	0.- Free V/f frequency7(Hz)	0.	
	b111	Free V/f voltage 6	0.-800.0(V)	0.0	
	b112	Free V/f frequency 7	0.-400.(Hz)	0.	
	b113	Free V/f voltage 7	0.-800.0(V)	0.0	
Intelligent input terminal setting	C001	Intelligent input 1 setting	01(RV:Reverse is valid)/02(CF1:Multi-speed1)/ 03(CF2:Multi-speed2)/ 04(CF3:Multi-speed3)/ 05(CF4:Multi-speed4)/ 06(JG:Jogging)/ 07(DB:External DC braking)/08(SET:2 nd control)/ 09(2CH:two-stage adjustable speed)/11(FRS:Free-run)/ 12(EXT:External trip)/13(USP:Unattended start protection)/ 14(CS:commercial change)/15(SFT:software lock)/ 16(AT:Analog input voltage/current select)/18(RS:Reset inverter)/ 20(STA:3wire run)/ 21(STP:3wire keep)/22(F/R:3wire forward/reverse)/ 23(PID:PID selection valid/invalid)/24(PIDC:PID integrating reset)/ 27(UP:Remote control UP function)/ 28(DWN:Remote control DOWN function)/ 29(UDC:Remote control data clear)/31(OPE:Force operate ope)/ 32(SF1:Multi-speed bit1)/ 33(SF2:Multi-speed bit2)/34(SF3:Multi-speed bit3)/ 35(SF4:Multi-speed bit4)/36(SF5:Multi speed bit5)/ 37(SF6:Multi-speed bit6)/38(SF7:Multi-speed bit7)/ 39(OLR:Overload restriction change)/no(NO:No assign)	18	
	C002	Intelligent input 2 setting		16	
	C003	Intelligent input 3 setting		03/13/03	
	C004	Intelligent input 4 setting		02	
	C005	Intelligent input 5 setting		01	
Input terminal setting intelligent	C011	Intelligent input1 a/b (NO/NC) selection	00(NO)/01(NC)	00	
	C012	Intelligent input2 a/b (NO/NC) selection	00(NO)/01(NC)	00	
	C013	Intelligent input3 a/b (NO/NC) selection	00(NO)/01(NC)	00/01/00	
	C014	Intelligent input4 a/b (NO/NC) selection	00(NO)/01(NC)	00	
	C015	Intelligent input5 a/b (NO/NC) selection	00(NO)/01(NC)	00	
	C019	Input FW a/b (NO/NC) Selection	00(NO)/01(NC)	00	
Intelligent output terminal setting	C021	Intelligent output 11 setting	00(RUN:running)/01(FA1:Frequency arrival type1 signal)/ 02(FA2:frequency arrival type2 signal)/03(OL:Overload advance notice signal)/04(OD:Output deviation for PID control)/05(AL:Alarm signal)/06(FA3:Only setting frequency)/08(IP:On instantaneous stop/ 09(UV:Under voltage)/11(RNT:RUN time over)/12(ONT:ON time over)/	01	
	C022	Intelligent output 12 setting		00	
	C026	Alarm relay output		05	
	C027	FM selection	00(Output frequency)/01(Output current) / 03(Digital output frequency)/04(Output voltage)/ 05(Input electric power)/06(thermal load rate)/07(LAD frequency)	00	
	C028	AM selection	00(Output frequency)/01(Output current)/04(Output voltage)/ 05(Input electric power)/06(thermal load rate)/07(LAD frequency)	00	
C029	AMI selection	00(Output frequency)/01(Output current)/04(Output voltage)/ 05(Input electric power)/06(Thermal load rate)/07(LAD frequency)	00		
Output terminal state setting, Output level setting	C031	Intelligent output 11 a/b	00(NO)/01(NC)	00	
	C032	Intelligent output 12 a/b	00(NO)/01(NC)	00	
	C036	Alarm relay output a/b	00(NO)/01(NC)	01	
	C040	Overload advance notice signal output mode	00(On accel. And decel, constant speed)/01(Only constant speed)	01	
	C041	Overload advance notice level	0.0-2.0*rated current(A)	Inverter rated current	
	C042	Frequency arrival setting for acceleration.	0.00-99.99/100.0-400.0(Hz)	0.00	
	C043	Arrival frequency setting for deceleration.	0.00-99.99/100.0-400.0(Hz)	0.00	
	C044	PID deviation setting level	0.0-100.0(%)	3.0	

Function Mode

	Code	Function name	L300P Setting range	Initial data -FE/-FU/-FR	Note
Communication function	C070	Data command	02(operator)/03(RS485)/04(option1)/05(option2)	02	
	C071	Communicating transmission speed	02(loop-back test)/03(2400bps)/04(4800bps)/05(9600bps)/06(19200bps)	04	
	C072	Communication code	1 - 32	1	
	C073	Communication bit	7(7bit)/8(8bit)	7	
	C074	Communication parity	00(no parity name)/01(even parity)/02(odd parity)	00	
	C075	Communication stop bit	1(bit)/2(bit)	1	
	C078	Communication waiting time	0.-1000.(ms)	0.	
	Analog meter setting	C081	O adjustment	0.-9999./1000-6553(10000-65530)	Setting on forwarding
C082		O1 adjustment	0.-9999./1000-6553(10000-65530)	Setting on forwarding	
C083		O2 adjustment	0.-9999./1000-6553(10000-65530)	Setting on forwarding	
C085		Thermistor adjustment	0.0 - 1000.	105.0	
C086		AM offset adjustment	0.0 - 10.0(V)	0.0	
C087		AMI adjustment	0. - 255.	80	
C088		AMI offset adjustment	0. - 20.0(mA)	4.0	
The others		b034	RUN time/Power ON time level	0.-9999./1000-6553(10000-65530)hr	0.
	b035	Operation direction restrict	00(Reverse is valid)/01(Only forward)/02(Only reverse)	00	
	b036	Start reduced voltage	00(Start reduced voltage time small) -06(Start reduced voltage time large)	06	
	b037	Display selection	00(all display)/01(each function display)/ 02(User setting / main setting)	00	
	b080	AM adjustment	0. - 255.	180	
	b081	FM adjustment	0. - 255.	60	
	b082	Start frequency adjustment	0.10-9.99(Hz)	0.50	
	b083	Carrier frequency setting	0.5-12.0(kHz) Derating enable, <0.5-8.0kHz>	3.0	
	b084	Initialize mode	00(Trip history clear)/01(Data initialization)/ 02(Trip history clear + data initialization)	00	
	b085	Country code for initialization	00(Interior)/01(EC)/02(USA)	01/02/00	
	b086	Frequency scalar conversion factor	0.1-99.9	1.0	
	b087	STOP key enable	00(valid)/01(invalid)	00	
	b088	Resume on FRS cancellation mode	00(0Hz start)/01(Start f-equaling)	00	
	b090	BRD usage ratio	0.0-100.0(%)	0.0	
	b091	Stop mode selection	00(deceleration stop)/01(Free-run stop)	00	
	b092	Cooling fan control	00(Always ON)/01(ON during run, After power ON, then for 5 minutes on stop is implied.)	00	
	b095	BRD selection	00(Invalid)/01(valid<invalid during stop>)/ 02(valid<valid during stop>)	00	
	b096	BRD ON level	330-380/660-760(V)	360/720	
	b098	Thermistor selection	00(Invalid)/01(Positive temperature coefficient enable)/ 02 (NTC enable)	00	
	b099	Thermistor error level	0. - 9999. (ohm)	3000.	
	C061	Thermal warning level	0. - 100. (%)	80	
	C091	Debug mode selection	00(No display)/01(Display)	00	
	C101	UP/DWN selection	00(No frequency data)/01(Keep frequency data)	00	
	C102	Reset selection	00(Trip cancel during ON)/01(Trip cancel during OFF)/ 02(Valid only during trip<Cancel during ON>)	00	
	C103	Reset f frequency matching selection	00(0Hz start)/01(Start f-equaling)	00	
	C121	O zero adjustment	0.-9999./1000-6553(10000-65530)	Set on forwarding	
	C122	O1 zero adjustment	0.-9999./1000-6553(10000-65530)	Set on forwarding	
	C123	O2 zero adjustment	0.-9999./1000-6553(10000-65530)	Set on forwarding	
	H003	1 st allowable motor selection	0.20-90.0(kW) <0.20-160(kW)>	Set on forwarding	
	H203	2 nd allowable motor selection	0.20-90.0(kW) <0.20-160(kW)>	Set on forwarding	
	H004	1 st motor pole selection	2/4/6/8(pole)	4	
	H204	2 nd motor pole selection	2/4/6/8(pole)	4	
	H006	1 st stabilized factor	0. - 255.	100.	
	H206	2 nd stabilized factor	0. - 255.	100.	
	P001	Option1 operation selection on error	00(TRP)/01(RUN)	00	
	P002	Option2 operation selection on error	00(TRP)/01(RUN)	00	
	P031	Digital input option input mode selection(Acc/Dec)	00(operation)/01(option1)/02(option2)	00	
	P044	DeviceNet running order of monitoring timer setting	0.00-99.99s	1.00	
	P045	Setting in action of abnormal communication	00(trip)/01(trip after deceleration stop)/02(Invalid)/ 03(free-run)04(deceleration stop)	0.	
	P046	Output assemble instance Number setting	20,21,100	21	
P047	Input assemble instance Number setting	70,71,101	71		
P048	Detect of idol mode for motion setting	00(trip)/01(trip after deceleration stop)/02(Invalid)/ 03(free-run)04(deceleration stop)	01		
P049	Pole setting of rotation speed	0-38(even only)	0		

(Note) < > indicate the setting range of 90 to 132kW

(Note1) P044-P049 are displayed on a 0.4-75kW model.















Function Mode





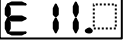

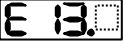
Code	Function name	L300P Setting range	Initial data -FE/-FU/-FR	Note
User selection	U001	User1 selection	no/d001-P040 <P031>	no
	U002	User2 selection	no/d001-P040 <P031>	no
	U003	User3 selection	no/d001-P040 <P031>	no
	U004	User4 selection	no/d001-P040 <P031>	no
	U005	User5 selection	no/d001-P040 <P031>	no
	U006	User6 selection	no/d001-P040 <P031>	no
	U007	User7 selection	no/d001-P040 <P031>	no
	U008	User8 selection	no/d001-P040 <P031>	no
	U009	User9 selection	no/d001-P040 <P031>	no
	U010	User10 selection	no/d001-P040 <P031>	no
	U011	User11 selection	no/d001-P040 <P031>	no
	U012	User12 selection	no/d001-P040 <P031>	no

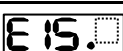
(Note) < > indicate the setting range of 90 to 132kW

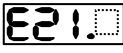
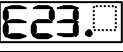
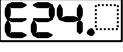
2. TROUBLE SHOOTING









2.1 Inverter trip contents, remedy, advice

Trip	contents	Digital operator display	Remedy, advice
Over current detection at output stage	<p>It's one of INV failure by locked motor, fast ACC/DEC because big current will be flown.</p> <p>By over current detection, INV will shut the output by the hardware. This detection will be done by AC CT.</p> <p>Over current will be detected about 200% of rated level on SJ300.</p> <p>Over current will be detected about 150% of rated level on L300P.</p>	While constant speed	E01.  Load changed rapidly. Short circuit or earth contact (ground fault) in the motor or the motor cable.
		While deceleration	E02.  If fast deceleration is happening preset Decel time longer
		While acceleration	E03.  If fast acceleration is happening preset Accel time longer Any motor locked, check the wires High preset torque boost, reduce the value
		others	E04.  Is the preset DC injection brake level high Any CT malfunction, any noise
Over load detection at output stage(with motor)	<p>INV is monitoring the output current, if the connected motor was overload conditions, INV will detect the overload, if the level was exceeded preset level, INV will shut the output.</p> <p>(E-thermal characteristic has deleting characteristic by the output freq. If the freq. Is less than 5Hz, it has more chance to have the trip.</p> <p>Over current will be detected about 200% of rated level on SJ300.</p> <p>If the load has big inertia moment, while ACC, there is a possibility to disturb the ACC by the detection.</p> <p>In this case, adjust torque boost if v/f control is selected.</p>	E05. 	<p>Too heavy load</p> <p>Thermal level proper ?</p> <p>Perform above adjustment referring to d104, to reduce the electronic thermal level.</p>
Over voltage detection after BRD %ED was run out	This detection is over voltage detection, but the condition is different from the normal over voltage trip. The difference is below. If the preset BRD %ED level(d090) was run out, BRD circuit can not work and if DC bus voltage will detect the over voltage level, INV will shut the output.	E06. 	<p>Any fast decel</p> <p>Busy running cycle</p> <p>Preset BRD%ED proper ? low ?</p> <p>Perform above adjustment referring to d103, to reduce the BRD usage ratio.</p>
Over voltage detection (DC bus voltage)	<p>If DC bus voltage is exceeded specific level by generating energy from the connected motor, high incoming AC voltage, INV will shut the output.</p> <p>The DC bus voltage level is</p> <p>About 400VDC (200V class)</p> <p>About 800VDC (400V class)</p>	E07. 	<p>Any fast decel</p> <p>Earth contact (ground fault) in the motor or the motor cable.</p> <p>Any back energy from the load</p> <p>Perform above adjustment referring to d102, so that the DC bus voltage does not exceed the trip level.</p>
EEPROM (contradiction)	INV uses EEPROM to preset parameters, if the EEPROM was affected by external noise, abnormal heat, micro processor will detect the contradiction such as sum check , INV will shut the output.	E08. 	<p>Any big noise near the INV</p> <p>Ambient temp. is too high.</p>
Under voltage(DC bus voltage)	<p>If DC bus voltage is low, INV can't work properly especially control circuit, in this case, INV will shut the output.</p> <p>The DC bus voltage level is</p> <p>About 200VDC or less(200V class)</p> <p>About 400VDC or less(400V class)</p>	E09. 	<p>Any incoming AC V drop</p> <p>Sufficient power capacity</p> <p>Any thyristor failure</p> <p>Perform above adjustment referring to d102, so that the DC bus voltage does not exceed the trip level.</p>
CT offset	<p>INV uses CT to detect motor current, if the CT outputs unusual offset level while INV stop, INV will shut the output.</p> <p>The voltage level is about 0.6V or more.</p>	E 10. 	Any high offset signal of the CT
CPU(micro processor mis-operation)	If built in Micro processor works improper, if it detects failure, INV will shut the output.	E 11. 	<p>Any big noise near the INV</p> <p>Micro processor failure</p>
External(customer's selection)	If the intelligent terminal detects the input signal from external devices, INV will shut the output. This function/trip is customer's selection. If EXT function is not selected, there is no chance to have the trip.	E 12. 	Check the configuration, signal, wiring, conditions
USP(US version default or customer's selection)	If INV is ready to start at power on, INV will shut the output. This function/trip is customer's selection. If USP function is not selected, there is no chance to have the trip.	E 13. 	Check the configuration,signal, wiring, conditions
Ground default at power on at output stage	Only at power on, INV will detect ground fault between INV and the connected motor, INV will shut the output. If the motor remaining voltage exists, this detection doesn't work.	E 14. 	Earth contact (ground fault) in the motor or the motor cable., IGBT failure
Incoming over voltage detection	<p>If DC bus voltage is continuously exceeding specific level more than 30 sec, INV will shut the output.</p> <p>The DC bus voltage level is</p> <p>About 380VDC or above (200V class)</p> <p>About 760VDC or above (400V class)</p>	E 15. 	<p>Any high incoming voltage except deceleration</p> <p>implement input ACL</p>



Trip	contents	Digital operator display	Remedy, advice
Instant power failure detection	If Instant power failure 15ms or more happened, INV will shut the output. If the instant power failure is longer than preset allowable time or affordable control supply voltage time, INV will work as normal power off. This means INV will re-start with the run command after the long instant power failure.		Any incoming AC V drop No contact failure in MCB,Mg?
Over heat detection	If main circuit temp. was exceeded specific level such as high ambient temp., fan failure, INV will shut the output. The temp. is detected at heat sink over 100 Celsius.		Any cooling fan failure, disturbance of the cooling such as dusty fin. Installation vertical Ambient temp. high
Gate array(INV domestic problem)	If there was any communication error between micro processor and gate array, or if gate array can't detect IGBT's turn on/off such as IGBT failure.		Any big noise near the INV Any IGBT failure Connection of flat cable/ribbon cable
Input phase failure detection	If one of incoming 3 phase voltage was missed, INV will shut the output if the detect function was preset. The detection delay is about 1 sec.		Any missing phase No contact failure in MCB,Mg?
IGBT over current detection (equivalent as power module)	If instant over current happened between INV and the connected motor, INV will shut the output. Under this INV trip, the detected phase is possible to refer at d105 display. Even retry function is preset, INV can not retry after this detection.		Short circuit or earth contact (ground fault) in the motor or the motor cable Any IGBT failure Any loose connection on main circuit such as power board
Thermister(customer's selection)	If motor over temp. happened by integrated thermistor's resistor value in the motor, INV will shut the output.		Check the motor temp. Any thermistor failure in the motor Any noise in the thermistor signal
Brake error (customer's selection)	After INV output brake release signal, INV couldn't detect brake on/off within b124(waiting time for brake operation. (if b120(brake control switch) was preset "01")		Is the brake working ON/OFF Preset B124 too short Brake signal/connection OK
Option board 1 error 0–9	Detection of connected option card 1. For more details, refer to the instruction manual of the card.		Make sure the connection of the card 1 Make sure if the usage is proper
Option board 2 error 0-9	Detection of connected option card 2. For more details, refer to the instruction manual of the card.		Make sure the connection of the card 2 Make sure if the usage is proper
Power off/ waiting from AC incoming voltage recovery	Stand by condition because of low DC bus voltage such as power off, INV will shut the output. The detection level is same as under voltage trip.		Any incoming AC V drop No contact failure in MCB,Mg? Check the DC bus voltage Perform above adjustment referring to d102, so that the DC bus voltage does not exceed the trip level.

2.2 Option error

2.2.1 Feed-back board (SJ-FB)











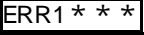





Trip	Contents	Digital operator display	Remedy, advice
Encoder wire cut	<ul style="list-style-type: none"> ✓ Wire break and/or loose connection of the encoder signal. ✓ Encoder failure or used the encoder which is not line driver output. ✓ Used encoder without Z phase signal. 	 	<ul style="list-style-type: none"> ✓ Check the wiring. ✓ Replace recommended encoder. ✓ Set SWENC-2 "OFF" on the card.
Over speed	Detect when the motor rotation exceeds (Maximum frequency) × (over speed detection level (P026))	 	<ul style="list-style-type: none"> ✓ Tune Kp and J parameters which are related to ASR to reduce the speed overshoot.
Positioning error	Detects when the deviation between actual position and position command exceeds 1,000,000 pulses.	 	<ul style="list-style-type: none"> ✓ Increase position loop gain of APR. ✓ Decrease the input pulses per second of the pulse train input.
Connection error	It displays, when the poor connection with SJ-FB is detected.	 	<ul style="list-style-type: none"> ✓ Make sure the connection of the board ✓ Make sure if the usage is proper

2.2.2 Digital-input option board (SJ-DG)

Trip	contents	Digital operator display	Remedy, advice
Option card error	To detect the option card error(failure)	 	<ul style="list-style-type: none"> Make sure the connection of the board Make sure if the usage is proper

2.2.3 Device- Net option board (SJ-DN)

The error display at the time of device network option board (SJ-DN) connection

Trip	contents	Digital display operator	Display of remote operator 
DeviceNet communication error	It displays, when connection cutting and the timeout by Bus-Off etc. occur at the time of operation by DeviceNet instructions. (Trip by setup of P045 and P048)	 	 
Duplication MAC ID	It is shown that the apparatus of the same MAC ID exists in the same network.	 	 
External trip	The instance of Control Supervisor object 1 and Force by the attribute 17 Fault/Trip It displays, when set to 1.	 	 
Communication error of inverter	It displays, when a timeout occurs by the communication between an inverter and a DeviceNet option board.	 	 

2.3 Check of the trip monitor contents

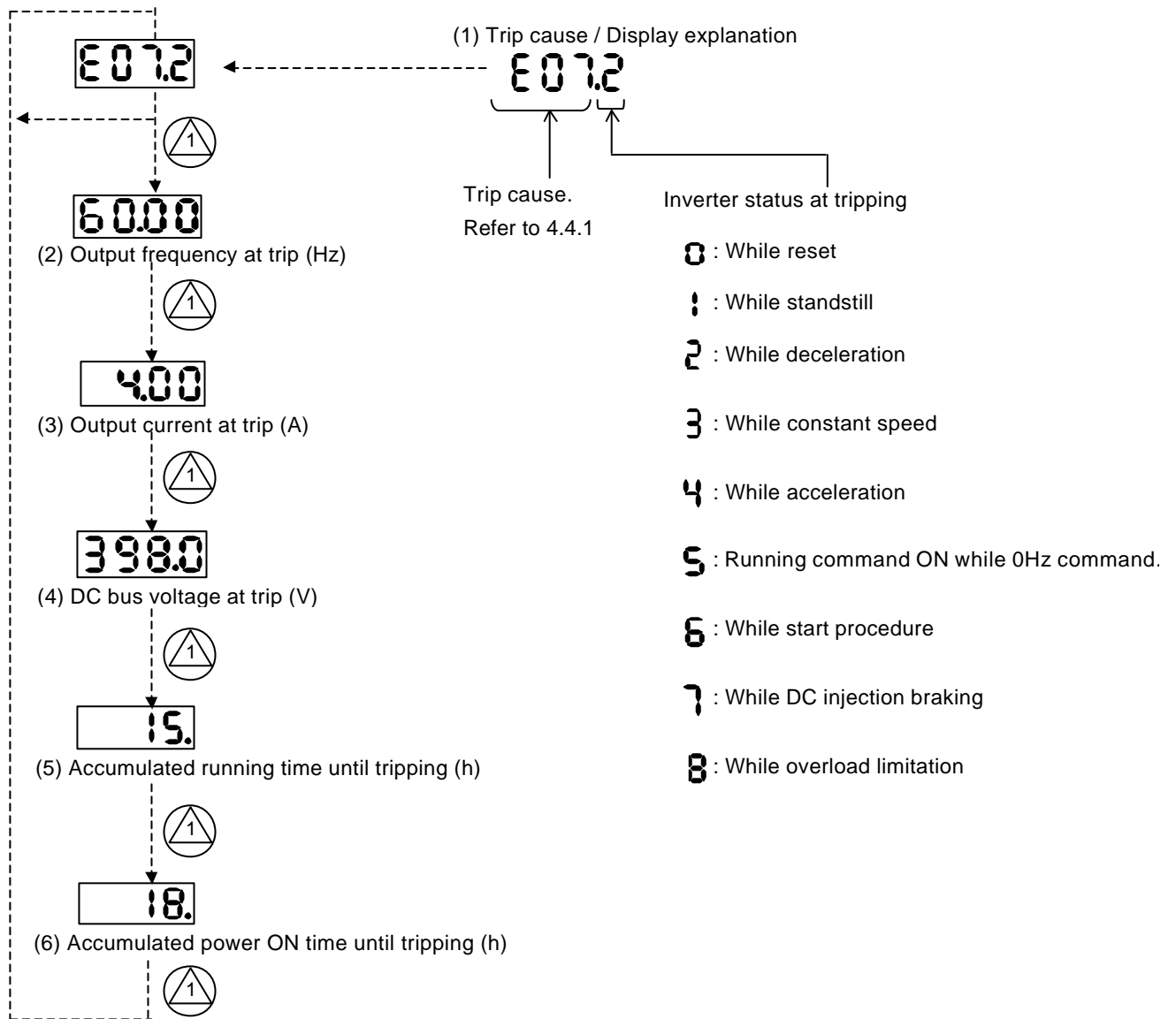

2.4 Check of the warning monitor contents

Warning message is come out when there is any contradiction.

Program lamp "PRG" is turned ON while warning (until the data are corrected).

Warning message and automatic rewriting

Warning	Related parameters	condition	Base
┌┐001/┌┐201	Frequency upper limiter A061/A261	>	Maximum frequency A004/A204
┌┐002/┌┐202	Frequency lower limiter A062/A262	>	
┌┐004/┌┐204	Base frequency A003/A203	>	
┌┐005/┌┐205	Output frequency F001, Multistage speed 0 A020/A220	>	
┌┐006/┌┐206	Multistage speed 1-15 A021-A035	>	
┌┐009	Orientation speed setting P015	>	
┌┐012/┌┐212	Frequency lower limiter A062/A262	>	Frequency upper limiter A061/A261
┌┐015/┌┐215	Output frequency F001, Multistage speed 0 A020/A220	>	
┌┐016/┌┐216	Multistage speed 1-15 A021 - A035	>	
┌┐021/┌┐221	Frequency upper limiter A061/A261	<	Frequency lower limiter A062/A262
┌┐025/┌┐225	Output frequency F001 , Multi stage speed 0 A020/A220	<	
┌┐031/┌┐231	Frequency upper limiter A061/A261	<	Start frequency b082
┌┐032/┌┐232	Frequency lower limiter A062/A262	<	
┌┐035/┌┐235	Output frequency F001 , Multi stage speed 0 A020/A220	<	
┌┐036	Multi stage speed 1-15 A021-A035	<	
┌┐037	Jogging frequency A038	<	
┌┐085/┌┐285	Output frequency F001 , Multi stage speed 0 A020/A220	<>	Jump freq. 1/2/3 +/- Jump width A063 +/- A064 A065 +/- A066 A067 +/- A068 (note 1)
┌┐086	Multi stage speed 1-15 A021-A035	<>	
┌┐091/┌┐291	Frequency upper limiter A061/A261	>	Free v/f 7 b112
┌┐092/┌┐292	Frequency lower limiter A062/A262	>	
┌┐095/┌┐295	Output frequency F001 , Multi stage speed 0 A020/A220	>	
┌┐096	Multi stage speed 1-15 A021-A035	>	
┌┐110	Free v/f frequency 1-6 b100,b102,b104,b106,b108,b110	>	Free v/f 1 b100
	Free v/f frequency 2-6 b102,b104,b106,b108,b110	<	Free v/f 1 b100
	Free v/f frequency 1 b100	>	Free v/f 2 b102
	Free v/f frequency 3-6 b104,b106,b108,b110	<	Free v/f 3 b104
	Free v/f frequency 1,2 b100,b102	>	Free v/f 3 b104
	Free v/f frequency 4-6 b106,b108,b110	<	Free v/f 4 b106
	Free v/f frequency 1-3 b100,b102,b104	>	Free v/f 4 b106
	Free v/f frequency 5,6 b108,b110	<	Free v/f 5 b108
	Free v/f frequency 1-4 b100,b102,b104,b106	>	Free v/f 5 b108
	Free v/f frequency 6 b110	<	Free v/f 6 b110
┌┐120	Free v/f frequency 1-5 b100,b102,b104,b106,b108	>	Free v/f 6 b110
	Free electronic thermal frequency 2,3 b017,b019	<	Free electronic thermal frequency 1 b015
	Free electronic thermal frequency 1 b015	>	Free electronic thermal frequency 2 b017
	Free electronic thermal frequency 3 b019	<	Free electronic thermal frequency 2 b017
	Free electronic thermal frequency 1,2 b015,b017	>	Free electronic thermal frequency 3 b019

Warning is cleared when the setting fulfils the above condition.

Date will be changed automatically to the basic code.

(note 1)The jump frequency will be automaically re-written to the lowest jump frequency

(=jump frequency - jump width)

2.5 Return to an initialization setup (Factory-shipment state)

The rewritten setting value is initialized and it can return to the state at the time of factory shipments.

The career of a trip is clearable.

The contents of initialization are as follows.

RUN time and power supply ON time are unclearable.

Item	FNC mode	Data	Contents
Initialization selection	b084	00	Only a trip career is cleared.
		01	Only initialization of setting value is carried out. Setting value will be in the state at the time of factory shipments.
		02	A clearance of a trip career and a setup are initialized.
Initial data selection	b085	00	Initial configuration value for inside of Japan
		01	Initial configuration value for Europe
		02	Initial configuration value for USA

(The initialization method)

Please initialize by the following methods after setting up the above and a setting item.

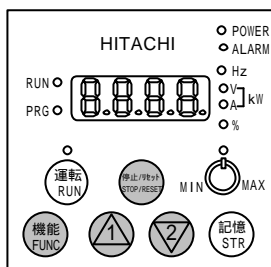

(1) Where a function key, a rise key, and a down key are pushed simultaneously, please push stop/reset key.

If a display blinks, please detach a stop/reset. Then, please detach a function key, a rise key, and a down key.

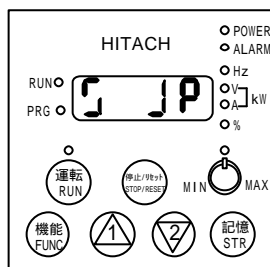

(2) Under initialization

The above-mentioned display is for the inside of Japan. Others are as follows.

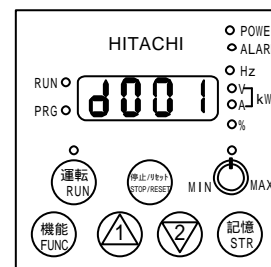

(3) When displayed on a monitor part as "d001", it is the completion of initialization.

Under initialization for Europe

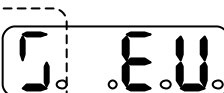

Under initialization for USA



Under trip career initialization

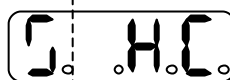

A display turns around a left end.

3.Debug Mode

Additional displays as follows can be seen by turning Debug mode ON (C091 ->1).

3.1 Monitor mode

No	Functional	Display code	SJ300/L300P A Monitor or data range
1	Control frequency monitor	d101	0.00-99.99/100.0-400.0Hz
2	Direct-current voltage monitor	d102	0.0-999.9V
3	BRD on-monitor	d103	0.00-99.99/100.0s
4	Electronic thermal monitor	d104	0.00-99.99/100.0%
5	Gate array trip factor monitor	d105	00-FF
6	MCU No. monitor	d106	0000-9999

d101 (Output frequency monitor (Hz)): Monitor of the output frequency of the inverter.

d102 (DC bus voltage monitor (V)): Monitor of the DC bus voltage (VPN) of the inverter.

d103 (BRD ON monitor (s)): There is an integrated BRD circuit on 11kW and less for SJ300, and 15kW and less for L300P series. You can find accumulated turning ON time for the integrated BRD transistor.

d104 (Electronic thermal monitor (%)):You can find the usage ratio of electronic thermal performance as %.

d105 (Trip cause monitor of gate array):There are 8 items of trips which are detected by the internal gate array and these items are transmitted to MCU.

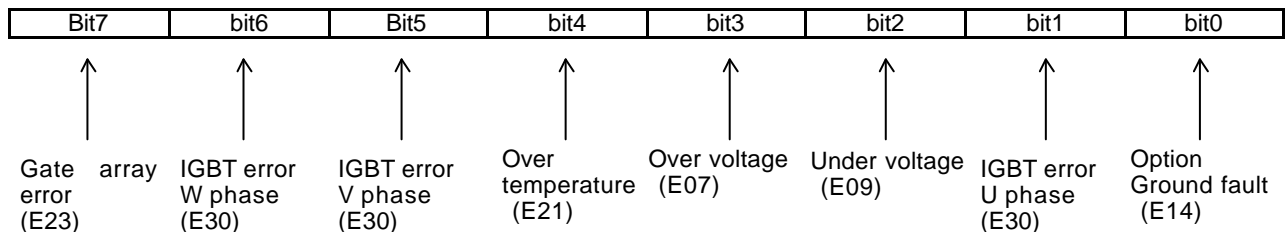

Contents of d105 are expressed in HEX.

(Example 1)

20
 20 (HEX) = 00100000 (BIN)
 bit5 = "1" -> IGBT error (V phase)

(Example 1)

62
 62 (HEX) = 01100010 (BIN)
 bit1, bit5, bit6 = "1" -> IGBT error (U, V, W phase)

d106(MCU No monitor): Display the software management number of MCU incorporated.

3.2 Function mode

Inverter (logic board) settings can be done as follows.

NO.	Functional	Display code	SJ300/L300P A monitor or data range
6	For factory adjustment (change prohibition)	C170 to C194	change prohibition
18	Inverter area code selection	C195	JP(for Japan)/EU(for EC)/USA(for USA)
19	Inverter capacity code selection	C196	0.2(0.2)-55.0(75.0)<75.0(90.0)-132.0>
20	Inverter voltage class code selection	C197	200(200V class)/400(400V class)
21	Inverter mode change selection	C198	00(SJ300)/01(L300P)

Be sure to perform initialization according to the instruction manual after change the data above.

Parameter b085 is prior to C195.

3.3 A setup of an inverter

The logic board of 55 or less kW's is common by each capacity (0.4-55kW) and the voltage class (200/400V).

Please check that name plate of logic is after SJ300P-L K.

However, it is necessary to unite with an inverter main part and to set up a logic board.

3.3.1 Setting procedure

(1) Preparation before switching on a power supply

(1)-1 Please connect a digital operator.

(2) Please carry out a power supply injection.

(3) Each code of an inverter use area, output capacity, and voltage class and model selection, and initial data is set up.

(3)-1 It is made the debug mode.

(The setting method) Please display C091, push FUNC key, input 01 and push STR key.

(3)-2 A use area code is set up.

(The setting method) Please display C195, push FUNC key, choose either of the codes (JP, EU, USA) shown in Table 3, and push STR key.

(3)-3 An output capacity code is set up.

(The setting method) Please push FUNC key after displaying C196. Please push a FUNC key and choose the code SJ300 was shown in Table 1 and L300P was indicated to be to Table 2. Then, please push STR key.

(3)-4 A voltage class code is set up.

(The setting method) Please push FUNC key after displaying C197. Please push a FUNC key and choose the code SJ300 was shown in Table 1 and L300P was indicated to be to Table 2. Then, please push STR key.

(3)-5 A model selection code is set up.

(The setting method) Please push FUNC key after displaying C198. Please push a FUNC key and choose the code indicated to be to Table 4. Then, please push STR key.

(3)-6 Data is initialized.

(The setting method) Please display b085, push FUNC key, choose either of the codes (00, 01, 02) shown in Table 3, and push STR key.

(4) An initial data code is set up.

(4)-1 Initialization selection is performed. (see the 2-5 clause)

(The setting method) Please display b084, push FUNC key, input the 02 and push STR key.

Then, where a function key, a rise key, and a down key are pushed simultaneously, please push a stop key. Please detach a stop key, if a display blinks.

Then, please detach a function key, a rise key, and a down key.

It checks whether the set-up use area code is displayed during initialization.

(for Japan : JP , for Europe : EU , for USA : USA)

(5) Please carry out power supply interception after an initialization end (after displaying d001 again).

(6) Please re-switch on a power supply.

3.3.2 Initial configuration completion check procedure

(1) A setup of the voltage class is checked.

(The check method) Please display A082, push FUNC key and check that it is ***.

* Please check having become as shown below about a display of the portion of ***.

Model	Display
-LF/LFR	-> 200
-LFU	-> 230

Model	Display
-HF/HFR	-> 400
-HFE	-> 400
-HFU	-> 460

(2) A setup of output capacity is checked.

(The check method) Please display H003, push FUNC key and check that it is ***.

* Please check having become as shown in H003 of Table 1 and Table 2 about a display of the portion of ***.

(3) Model selection of SJ300/L300P is checked.

(The check method) Please display H-- and check that the displays when pushing FUNC key once are SJ300:H001 and L300P:H003.

Table1. The correspondence table by the setting code model of SJ300

Code Model	C196 (Output capacity)	C197 (Voltage class)	H003 (motor capacity)	Code Model	C196 (Output capacity)	C197 (Voltage class)	H003 (motor capacity)
-004LF/LFU	0.4	200	0.4	-007HF/HFE/HFU	0.75	400	0.75
-007LF/LFU	0.75	200	0.75	-015HF/ HFE/HFU	1.5	400	1.5
-015LF/LFU	1.5	200	1.5	-022HF HFE/HFU	2.2	400	2.2
-022LF/LFU	2.2	200	2.2	-037HF/HFU	3.7	400	3.7
-037LF/LFU	3.7	200	3.7	-040HFE	3.7	400	4.0
-055LF/LFU	5.5	200	5.5	-055HF/HFE/HFU	5.5	400	5.5
-075LF/LFU	7.5	200	7.5	-075HF/HFE/HFU	7.5	400	7.5
-110LF/LFU	11.0	200	11.0	-110HF/HFE/HFU	11.0	400	11.0
-150LF/LFU	15.0	200	15.0	-150HF/HFE/HFU	15.0	400	15.0
-185LF/LFU	18.5	200	18.5	-185HF/HFE/HFU	18.5	400	18.5
-220LF/LFU	22.0	200	22.0	-220HF/HFE/HFU	22.0	400	22.0
-300LF/LFU	30.0	200	30.0	-300HF/HFE/HFU	30.0	400	30.0
-370LF/LFU	37.0	200	37.0	-370HF/HFE/HFU	37.0	400	37.0
-450LF/LFU	45.0	200	45.0	-450HF/HFE/HFU	45.0	400	45.0
-550LF/LFU	55.0	200	55.0	-550HF/HFE/HFU	55.0	400	55.0

Table2. The correspondence table by the setting code model of L300P

Code Model	C196 (Output capacity)	C197 (Voltage class)	H003 (motor capacity)	Code Model	C196 (Output capacity)	C197 (Voltage class)	H003 (motor capacity)
-110LFR/LFU	11.0	200	11.0	-110HFR/HFE/HFU	11.0	400	11.0
-150LFR/LFU	15.0	200	15.0	-150HFR/HFE/HFU	15.0	400	15.0
-185LFR/LFU	18.5	200	18.5	-185HFR/HFE/HFU	18.5	400	18.5
-220LFR/LFU	22.0	200	22.0	-220HFR/HFE/HFU	22.0	400	22.0
-300LFR/LFU	30.0	200	30.0	-300HFR/HFE/HFU	30.0	400	30.0
-370LFR/LFU	37.0	200	37.0	-370HFR/HFE/HFU	37.0	400	37.0
-450LFR/LFU	45.0	200	45.0	-450HFR/HFE/HFU	45.0	400	45.0
-550LFR/LFU	55.0	200	55.0	-550HFR/HFE/HFU	55.0	400	55.0

Table3. Use area code

Local selection code	C195 (Use area)	b085 (Initial data)
For Japan	JP	00
For EU	EU	01
For USA	USA	02

Table4. Model selection code

Model selection code	C198 (Model selection)
SJ300	00
L300P	01

4. The check of control power supply voltage and a control signal

4.1 Control power supply

Item	Tolerance level	Measurement place	
		+	-
PV5 +5V power supply	4.5V - 5.5V	J1 connector 25,16pin	Control terminal L
PV12 +12V power supply	10.8V - 13.2V	J1 connector 7pin	Control terminal L
NV12 -12V power supply	-13.2V - -10.8V	J1 connector 5pin	Control terminal L
PV24 24V power supply	21.6V - 26.4V	J1 connector 3,4pin, Control terminal P24	Control terminal CM1

4.2 Control signal

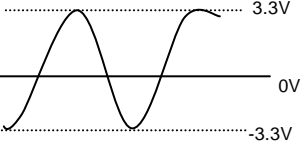
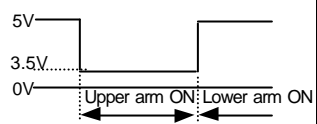
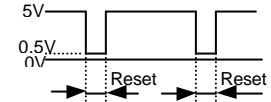
Signal	Measurement place	The contents of operation	Observation waveform
VDC	J1 connector 12pin-L	A main circuit direct-current voltage detected signal $VDC=6.396V/400V*VPN(200Vclass)$ $VDC=6.396V/800V*VPN(400Vclass)$	Direct-current voltage
IUF IWF	J1 connector 9pin-L J1 connector 8pin-L	A motor current detected signal At the time of inverter rated load: About 3.3 V peak	
TRIP	J1 connector 21pin-L	The signal at the time of carrying out a trip by the trip factor which a gate array judges (P3-1 reference) Normal : 5V(H) Inside of a trip : about 0.3V(L)	Direct-current voltage
PHF	J1 connector 22pin-L	Phase failure protection detected signal Normal :5V(H) Phase failure detection :about0.5V(L)	Direct-current voltage
IPL	J1 connector 11pin-L	The instantaneous power failure signal of R0-T0 part Power On : about0.5V(L) Power Off : 5V(H)	Direct-current voltage
GS	J1 connector 20pin-L	Power-module protection Under operation : about 5V(H) Under a stop : about 0.5V(L)	Direct-current voltage
US VS WS	J1 connector 17pin-L J1 connector 18pin-L J1 connector 19pin-L	PWM signal Upper arm ON : about 3.5V(L) lower arm ON : about 5V(H)	
GS	J1 connector 30pin-L	The trip distinguished by GA is canceled. Normal : about 5V(H) Under reset : about 0.5V(L)	

5. Maintenance and Inspection

5.1 Maintenance and Inspection

5.1.1 Daily inspection

Main check points to be done while operation are as follows.

- (1) Whether the motor rotates as expected.
- (2) Whether the installation condition have no problem.
- (3) Whether there is no problem in cooling.
- (4) Whether there is any abnormal vibration and noise.
- (5) Whether there is any abnormal temperature rising and change in color.
- (6) Whether there is any abnormal smell.

Measure the input voltage of the inverter by a tester while operation to confirm the followings.

- (1) No frequent voltage fluctuation.
- (2) All line voltages are balanced and stable.

5.1.2 Cleaning

Always keep the inverter clean.

Use soft cloth dipped with neutrality detergent or ethanol and wipe the dirty portion with care.

(note) Do not use such as acetone, benzene, toluene or alcohol which may damage the coating of the inverter.

5.1.3 Periodical inspection

Check the portions where the inverter must not be in operation.

Please contact HITACHI for a periodical inspection.

- (1) Is there any abnormality in cooling? ---- Cleaning of air filter.
- (2) Tightening check and additional tightening. ---- Loose tightening of the screws and bolts could occur due to vibrations and/or temperature changing. Be sure to confirm carefully.
- (3) Isn't there any corrosion or damage in the conductors?
- (4) Measurement of insulation resistance.
- (5) Check and replace of cooling fan, DC bus capacitors and relays if necessary.

5.2 Daily and annual maintenance

	Item	Contents	Interval		Method	Criteria
			D	A		
Overall	Ambient Environment	Check ambient temperature, humidity, dust, corrosive gas, oil mist etc.	X		Refer to 2.1. Installation	Ambient temperature: -10 ~ +50°C (no icing) No condensation
	Devices overall	Check for abnormal vibrations and noise.	X		Visual inspection	No abnormalities
	Power supply voltage	Check voltage between input lines	X		Measure the voltage between input terminals	No abnormalities and within specifications
Mains	Overall	Megger check (Power terminal - Earth)		X	Remove connector J61 Disconnect power line Remove logic terminal Make short circuit R, S, T, U, V, W, P, PD, N, RB Megger test between above and earth	> 5Mohm
		Check installation for looseness.		X	Tighten	No abnormalities
		Check for evidence of over heating in the various components		X	Visual inspection	No abnormalities
	Conductors / cables	Cleaning		X		
		No change in shape?		X	Visual inspection	No abnormalities
		No damage in coating?		X	Visual inspection	No abnormalities
	Terminal block	No damage?		X	Visual inspection	No abnormalities
	Inverter / Converter	Tester check between each terminal		X	Remove power cables Measure resistance; Each input ↔ P, N Each output ↔ P, N with 1ohm range	Refer to "5.5 How to measure inverter & converter" portion
	DC bus capacitor	Check for leaking liquid		X	Visual inspection	No abnormalities
		Check for swelling		X	Visual inspection	No abnormalities
		Check for capacitance		X	With capacitance meter	85% or more of rated capacitance
	Relay, contactor	Check for stuttering noise during operation		X	Aural inspection	No abnormalities
		No damage of contact?		X	Visual inspection	No abnormalities
Resistors	Check for cracks or changes in color		X	Visual inspection	No abnormalities	
	No open circuit?		X	Tester check	Tolerance of within ±10% of rated value	
Cooling	Cooling fan	Check for abnormal vibration and noise	X		Rotate manually during power off	Smooth rotation and no abnormalities
		Check for dust	X		Visual inspection	No abnormalities
Control circuit	Operation check	Check the balance of the output voltage of each phase to phase without motor.		X	Measure the output voltage between U, V and W	Within 2% of voltage difference between each phases.
		Perform a sequence protection operation test and make sure that there are no errors in the protection and display circuits.		X	Simulate operation of the protection circuit	Each protection should be performed
LED display	Display	No illegible display; No missing characters; No segment failure of LEDs	X		Visual inspection	No abnormalities
		Cleaning		X		
	Meter	Working correct?	X	X	Visual inspection	Displays correct value
Motor	Overall	No abnormal vibration & noise?	X		Visual, aural inspection	No abnormalities
		No abnormal smell?	X		Confirm the smell caused by overheat, damage etc.	No abnormalities
	Insulation resistance	Megger check All terminals together - Earth		X	Measure resistance; Each input ↔ Earth With and without motor cables	> 5Mohm

5.3 Megger test

Disconnect all the wiring in case of megger test on external circuit, so that no test voltage is supplied to the inverter. Use tester (high resistance range) for the test of control circuit. Do not use megger nor buzzer.

Megger test should be done only on the power (mains) portions. Do not perform megger test on control circuits.

(Use DC500V megger in case of megger test.)

In case of megger test on power terminals, disconnect short circuit material at connector "J61" located close to R0T0 terminal, and connect R, S, T, PD, P, N, RB, U, V and W all together. Connect again the short circuit material to J61 after the test is done.

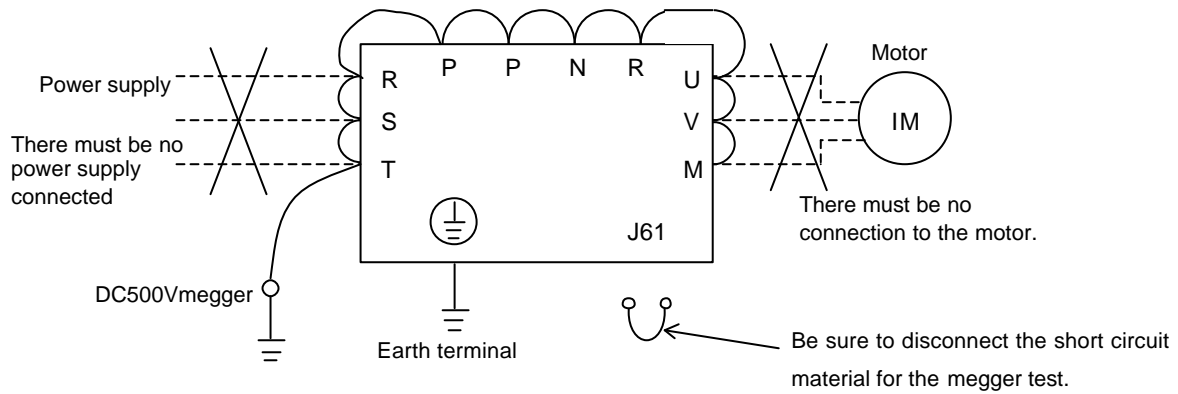

5.4 Withstand voltage test

Do not perform withstand voltage test.

Semiconductors that are used in inverter can be degraded when withstand voltage is performed.

5.5 How to check inverter & converter portion

Inverter and converter module can be checked by using a tester.

(Preparation)

- (1) Disconnect all the connected wires and devices to the power terminals (R, S, T, U, V, W, P and RB).
- (2) Tester is to be set as 1ohm range.

(How to check)

Check the ON condition of each point shown below.

(note 1) Be sure to discharge DC bus voltage beforehand, which should be checked by DC bus voltage.

(note 2) Normally, the resistance shows ∞ in case of OFF mode.

In some cases resistance does not show ∞ due to the capacitance of DC bus capacitors.

Resistance shows **3ohm ~ 50ohm** (depends on the tester voltage) in case of ON mode.

Resistance values may not be completely the same due to the electrical device (IGBT chip, diode chip...) difference.

But we can regard the result is okay if all the data are nearly the same.

		Tester polarity		Measurement
		⊕(Red)	⊖(Blk)	
Converter	D1	R	PD	OFF
		PD	R	ON
	D2	S	PD	OFF
		PD	S	ON
	D3	T	PD	OFF
		PD	T	ON
D4	R	N	ON	
	N	R	OFF	
	S	N	ON	
D5	N	S	OFF	
	T	N	ON	
	N	T	OFF	
Inverter	TR1	U	P	OFF
		P	U	ON
	TR3	V	P	OFF
		P	V	ON
	TR5	W	P	OFF
		P	W	ON
	TR4	U	N	ON
		N	U	OFF
V		N	ON	
TR6	N	V	OFF	
	W	N	ON	
	N	W	OFF	
BRD	TR7	RB	P	OFF
		P	RB	ON
		RB	N	OFF
		N	RB	OFF
Thyristor	THY	A	K	OFF
		A	G	OFF
		K	A	OFF
		K	G	ON
		G	A	OFF
		G	K	ON

ON; Low resistance

OFF; High resistance

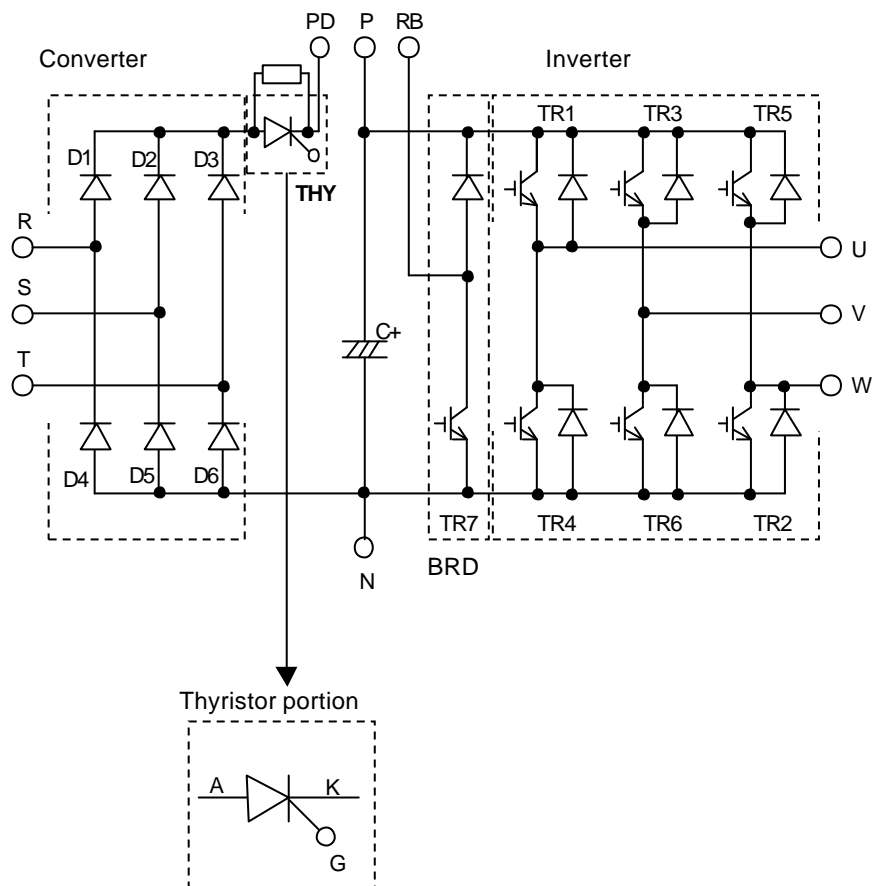

5.6 Parts replacement

Inverter is consists from many electrical components. And inverter cannot work properly unless all of them works normal. Electrical components in following table are the components which may degrade according to the usage period.

HITACHI recommend to replace those electrical components periodically to avoid any expected failure caused by them.

Parts name	Recommended period for replacement	Remarks
Cooling fan	2 ~ 3 years	Replace with fresh one.
DC bus capacitors	5 years	Replace with fresh one. (Decide after inspection.)
Electrolytic capacitors on PCB	5 years	Replace with fresh one. (Decide after inspection.)
Relays	-	Inspection in advance

(1) Cooling fan

Lifetime of the cooling fan depends on the usage condition, however it is normally around 35,000 hours. That means it is recommended to replace the cooling fan every 2 ~ 3 years in case the inverter operates continuously. Of course it should be replaced immediately in case the abnormality is found.

(How to remove cooling fan for mold case)

- ① Remove **terminal cover** and **front cover**.
- ② Reconfirm that the charge lamp is turned OFF.
- ③ Push both side of the cooling fan holder plate and pull out like following figure.
- ④ Remove the connector for fan connection.

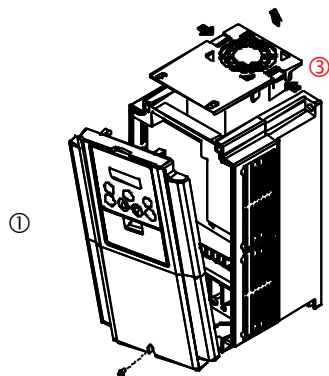

(How to fix cooling fan for mold case)

- ① Pay attention to the direction of the cooling fan.
- ② Connect the fan connector to J21 or J22 (depends on the model) on the power PCB.
- ③ Fix the **cooling fan holder board** to the inverter main body.
- ④ Fix the front cover and terminal cover.

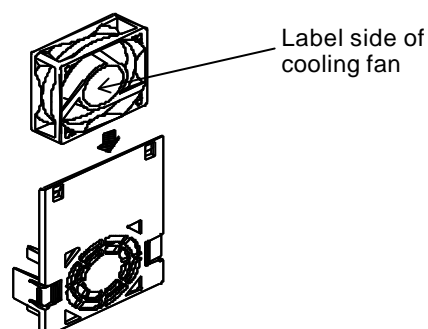

(How to remove cooling fan for steel case)

- ① Remove **terminal cover** and **front cover**.
- ② Reconfirm that the charge lamp is turned OFF.
- ③ Remove the all screws of the cooling fan case and pull out like following figure.
- ④ Remove the connector for fan connection.

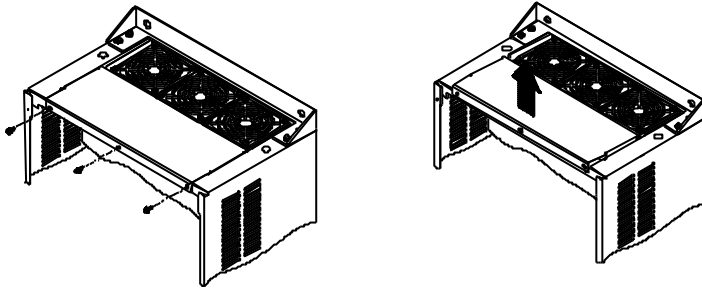

(How to fix cooling fan for steel case)

- ① Pay attention to the direction of the cooling fan.
- ② Connect the fan connector to J21 **or** J22 or J23 or J24 (depends on the model) on the power PCB.
- ③ Fix the **cooling fan case** to the inverter main body.
- ④ Fix the front cover and terminal cover.

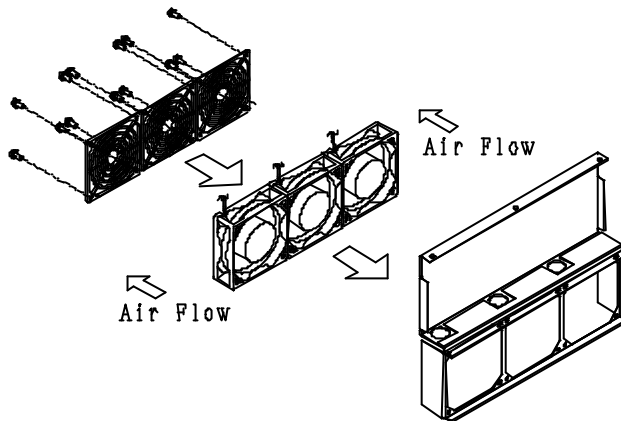

(2) DC bus capacitor

Big capacitance of electrolytic capacitors are used in a DC bus line of the inverter as a smoothing circuit. Due to the chemical reaction inside the capacitor, its lifetime highly depends on the ambient temperature and usage condition. Replacement is recommended to be done in 5 years under normal usage condition. Also, it should be anyway replaced with new ones when there is any abnormality is found or its capacity becomes less than 85% of its rated capacitance.

(How to remove DC bus capacitor for mold case)

- ① Remove terminal cover.
- ② Reconfirm that the charge lamp is turned OFF.
- ③ Remove blind cover.
- ④ Remove all the screws connecting capacitor PCB and power PCB.
- ⑤ Pull the capacitor PCB downwards.

(How to fix DC bus capacitors for mold case)

- ① Put capacitor PCB onto the capacitor holder plate and put insulation sheet on it.
- ② Insert capacitor holder plate sliding along the ditch.
- ③ Fix the capacitor PCB with screws.
- ④ Fix terminal cover.

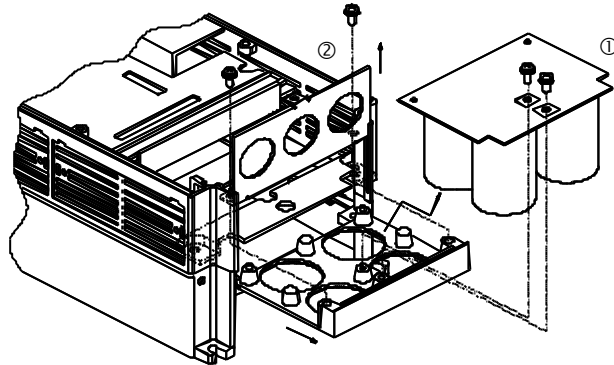

(How to remove DC bus capacitor for steel case)

- ① Remove terminal cover.
- ② Under a stop confirm that the charge lamp is turned OFF.
- ③ Remove all the screws connecting P,N BAR.
- ④ Remove all the screws connecting capacitor case and inverter main body.
- ⑤ Pull the capacitor case downwards.

(How to fix DC bus capacitors for steel case)

- ① Put capacitor onto the capacitor case and drive all the screws.
- ② Insert capacitor case sliding along the ditch.
- ③ Fix the capacitor case with screws.
- ④ Fix terminal cover.

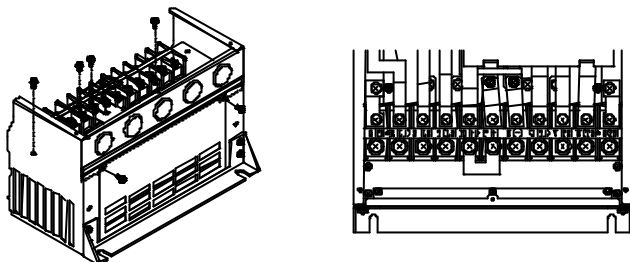

5.7 Unit replacement

Unit replacement can be done without rewiring of the logic signal.

(How to exchange)

- ① Remove terminal cover.
- ② Reconfirm that the charge lamp is turned OFF.
- ③ Remove the screws, right and left portion , like following figure.
- ④ Plug out the logic terminal carefully.
- ⑤ In case of plugging in to the new inverter, pay attention not to bend the connection pins.

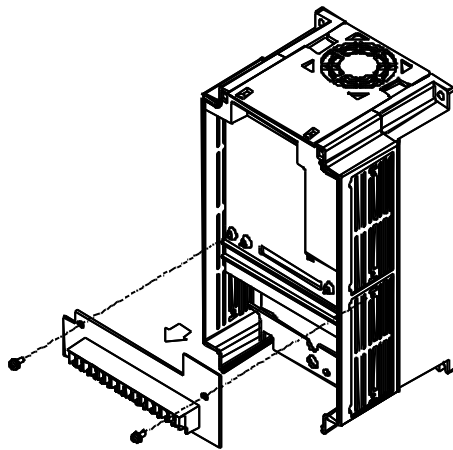

No.	English
1	CB circuit / DC bus capacitor circuit
2	CB board / DC bus capacitor board
3	Instantaneous power failure detection
4	Phase failure detection
5	Opt coupler / Photo coupler
6	Reference voltage
7	Inrush current limiting (circuit)
8	Thyristor drive circuit (Suppressing circuit)
9	Power supply for Thyristor gate
10	Control signal for Thyristor
11	BRD drive circuit (incl. Short circuit protection)
12	Control signal for BRD
13	Short circuit detection
14	Power supply for lower arm IGBTs
15	Drive circuit for lower arm IGBTs (incl.Short circuit detection)
16	Drive circuit for upper arm IGBTs (incl.Short circuit detection)
17	Power supply for U phase
18	Current detection for U phase
19	Current detection for W phase
20	Control power supply
21	Temperature detection
22	Control power supply
23	Power supply for GA (Gate Array)
24	Power supply for I/F (interface)
25	UV (Under voltage) detection
26	Instantaneous power failure detection
27	Dividing circuit
28	OV (Over voltage) detection
29	Voltage detection for each phase
30	f,sita detection
31	Main PCB
32	High speed opt coupler
33	Isolation amplifier
34	30 connections between main PCB and logic PCB
35	"H" while BRD ON
36	Approx. 3.3V peak at rated current
37	"L" while Inverter trips
38	"L" while phase failure
39	Communication signal,operates while standstill
40	PWM signal
41	Approx. 6.4V at OV level
42	"L" while stopped by Gate suppressing
43	Signal for frequency matching
44	Control power supply for digital portion
45	Control power supply for analog portion
46	Power supply for I/F (interface)
47	"H" while instantaneous power failure
48	OC(Over current)detection
49	Hardware latch
50	25 control terminals
51	31 control terminals
52	Logic PCB

Internal block diagram

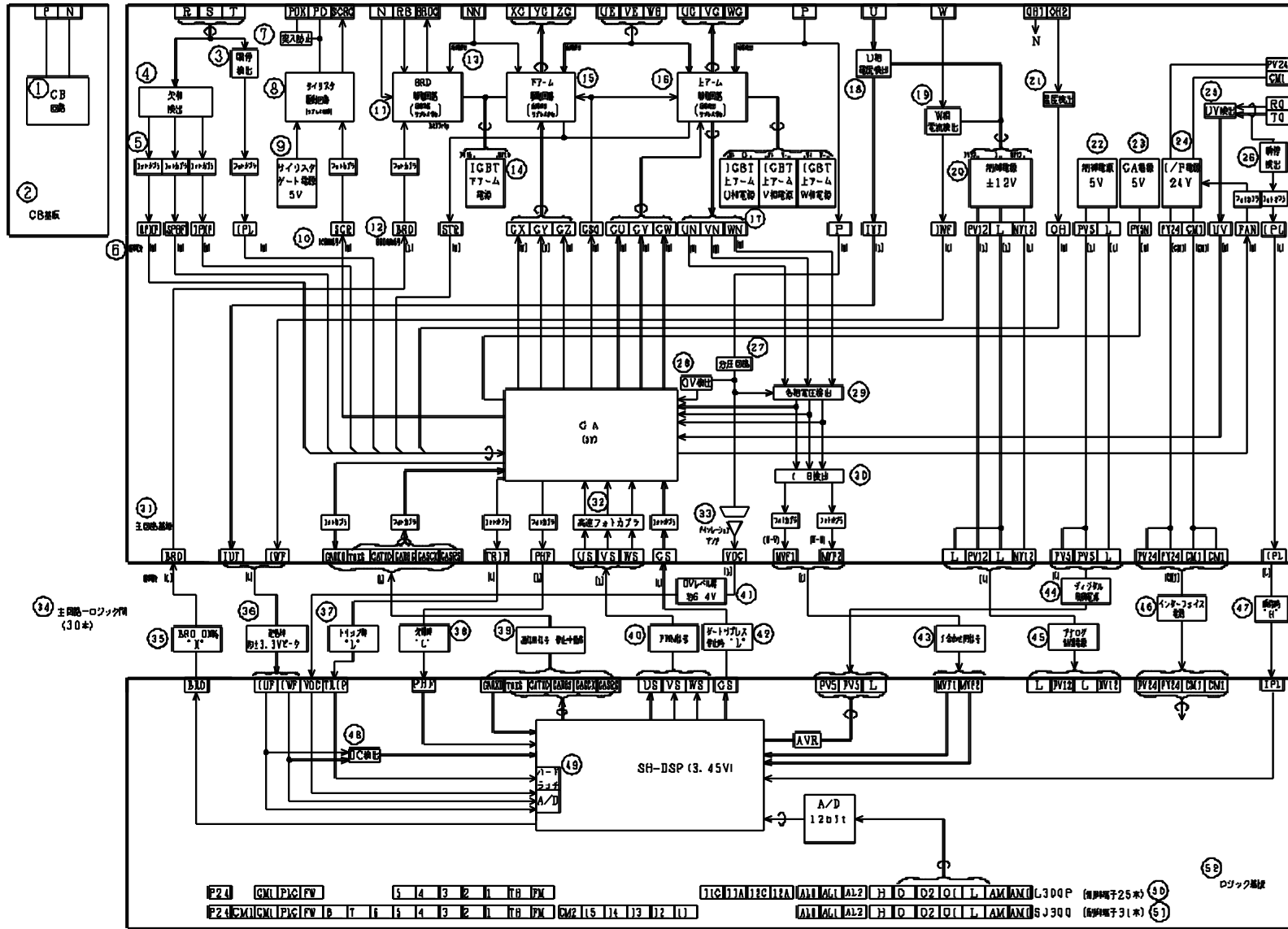

SJ300-004-007LF Circuit Diagram

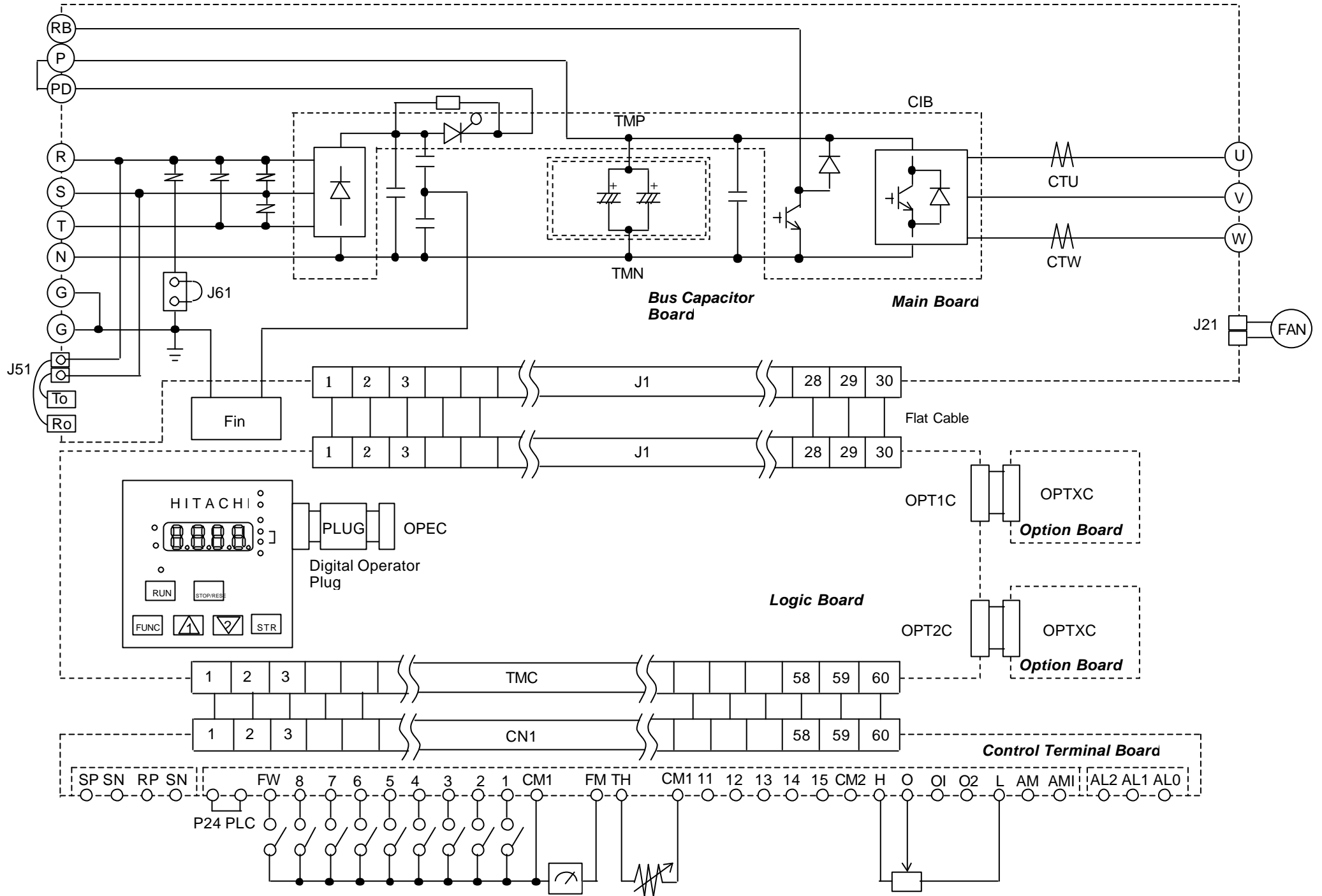

SJ300-015 - 055LF Circuit Diagram

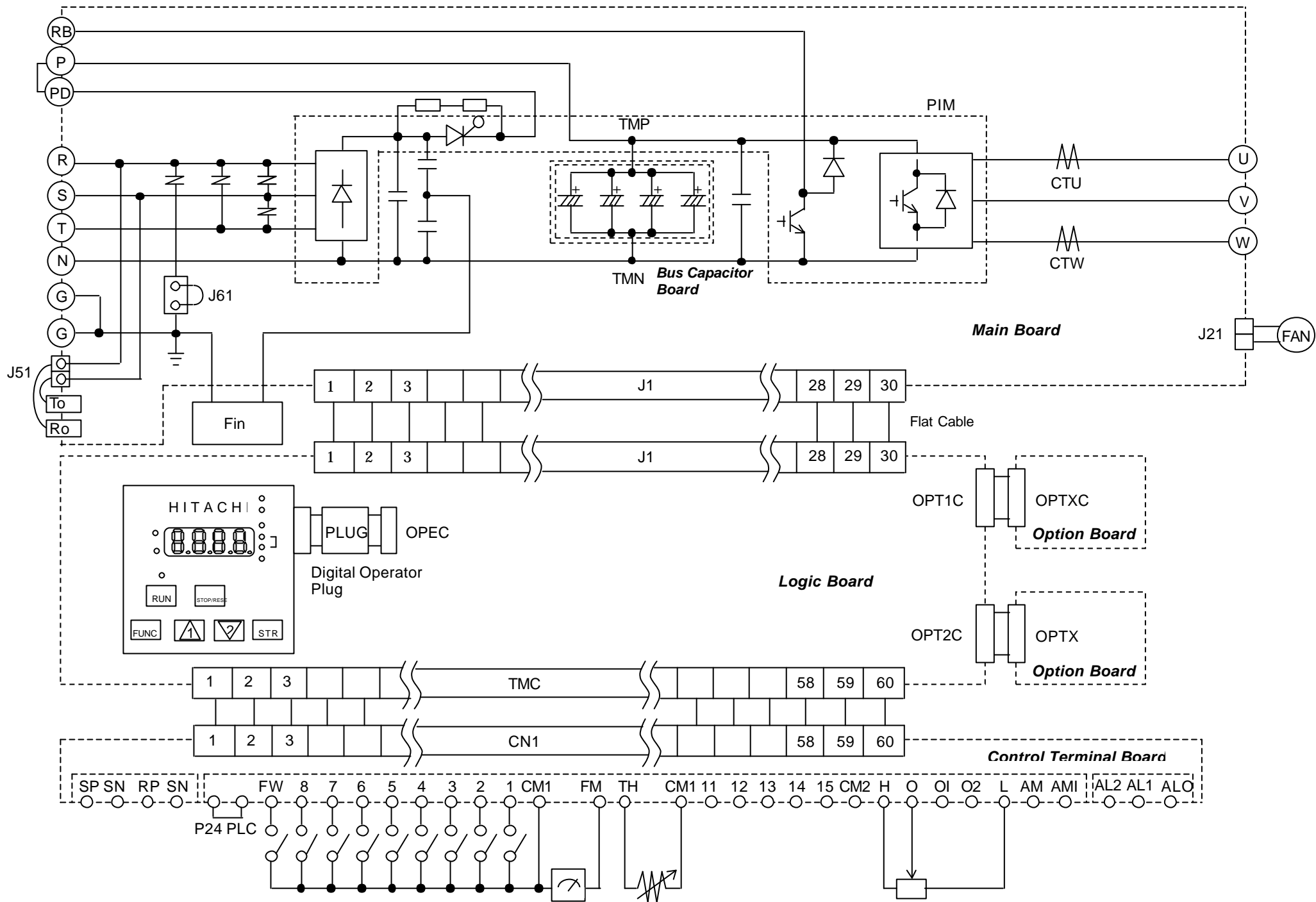

SJ300-075-110LF , L300P-110-150LFR Circuit Diagram

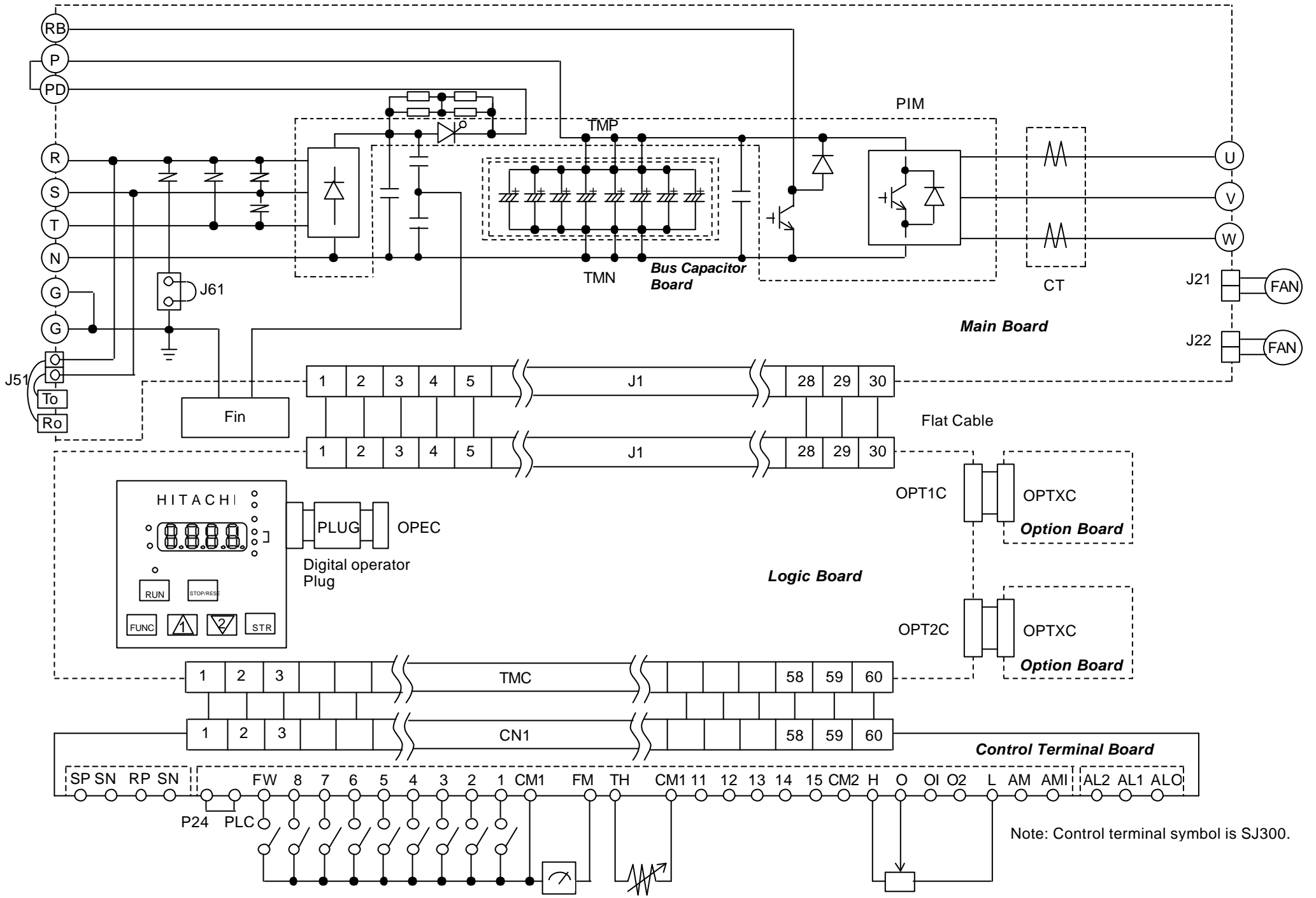

Note: Control terminal symbol is SJ300.

SJ300-150 - 220LF , L300P-185 - 300LFR Circuit Diagram

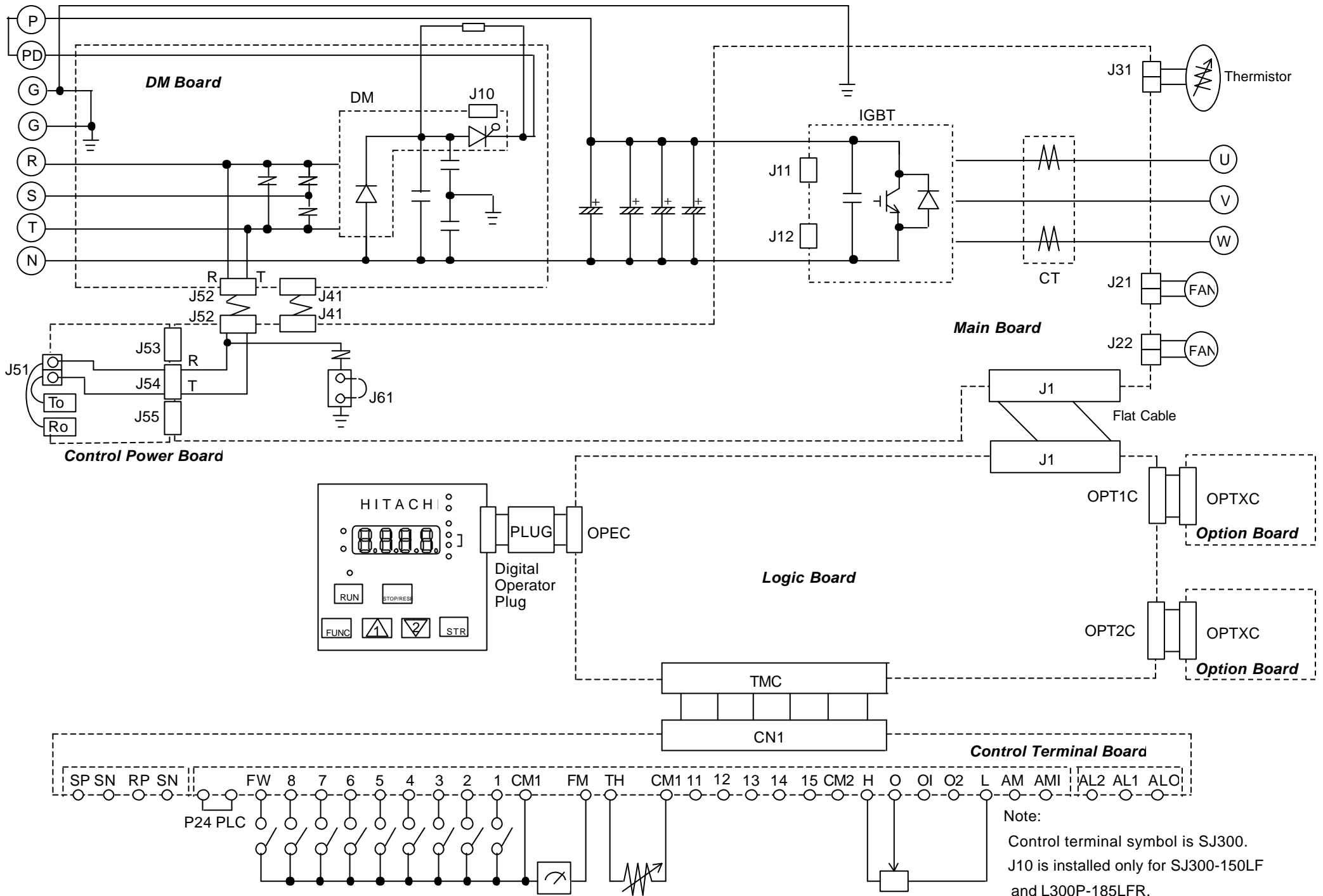

SJ300-300LF, L300P-370LFR Circuit Diagram

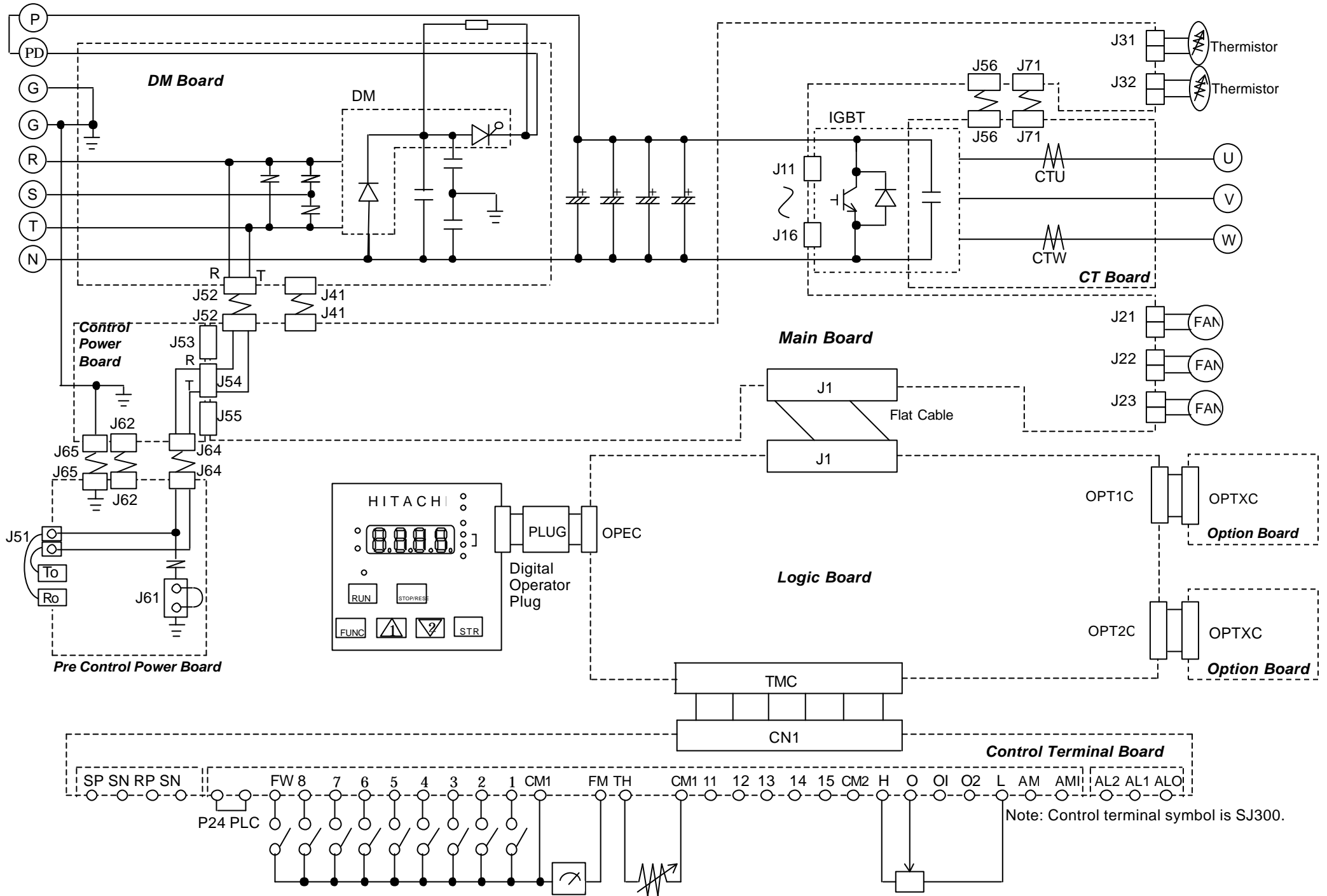

SJ300-370-450LF, L300P-450-550LFR Circuit Diagram

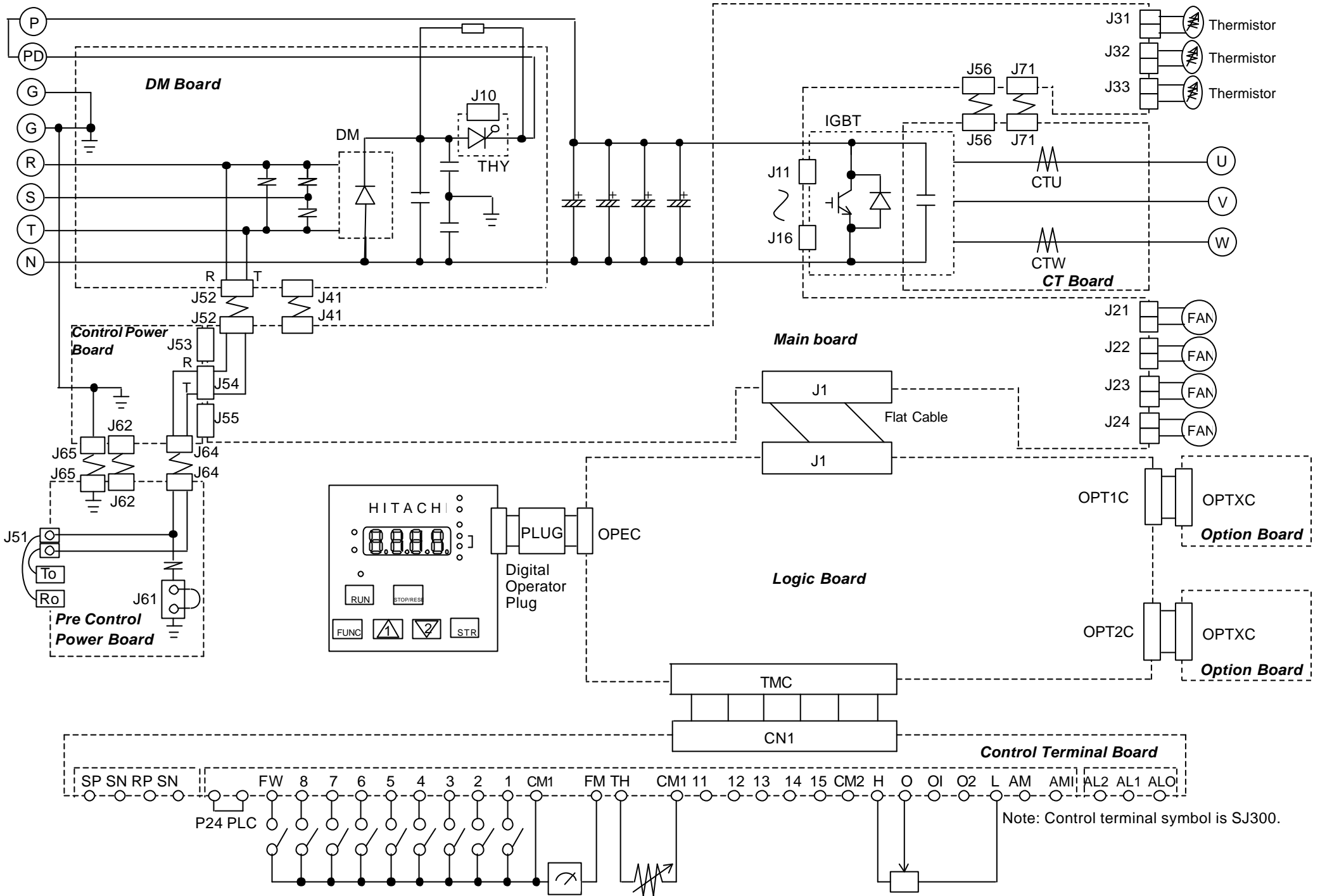

SJ300-550LF,L300P-750LFR Circuit Diagram

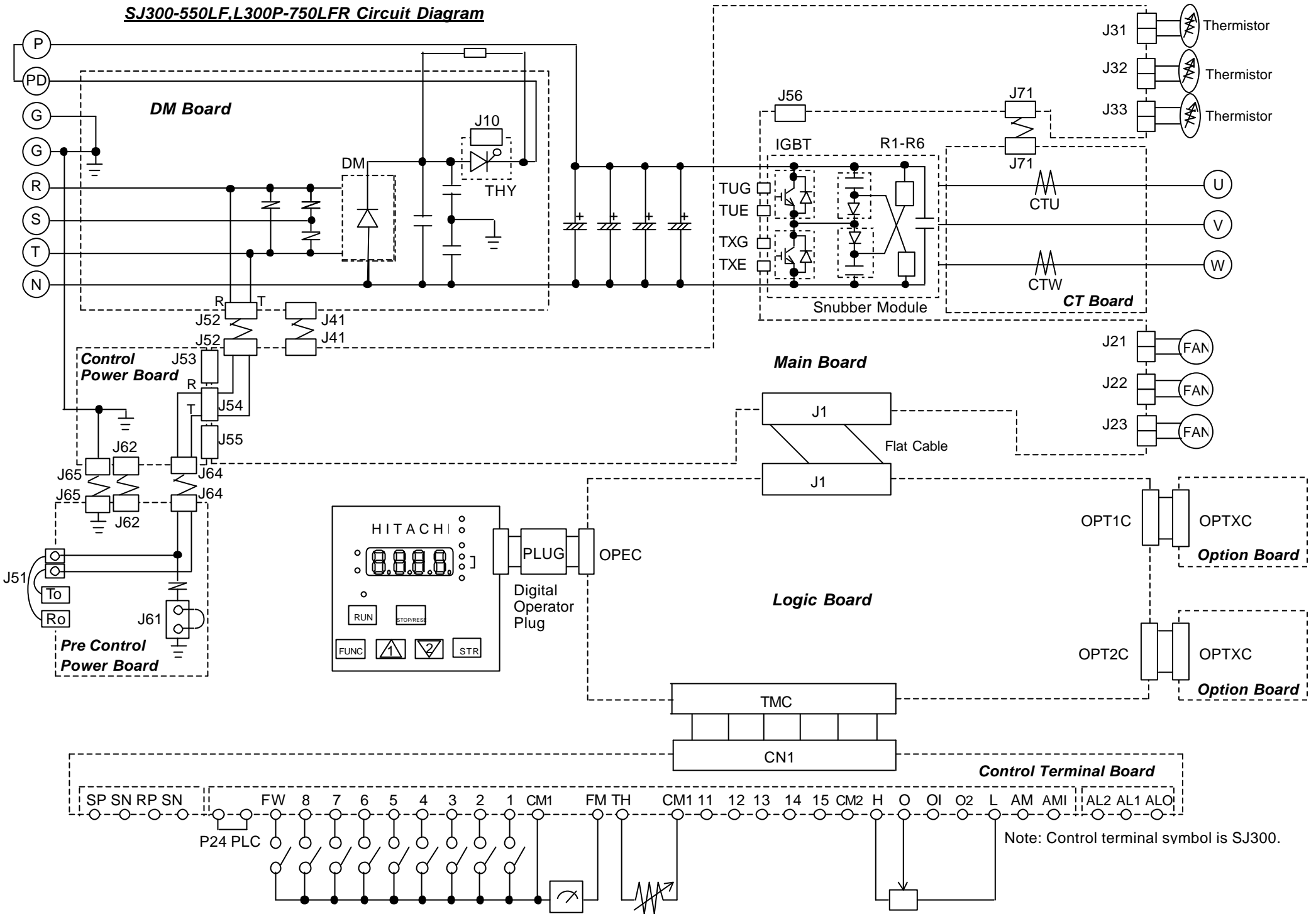

SJ300-007HF Circuit Diagram

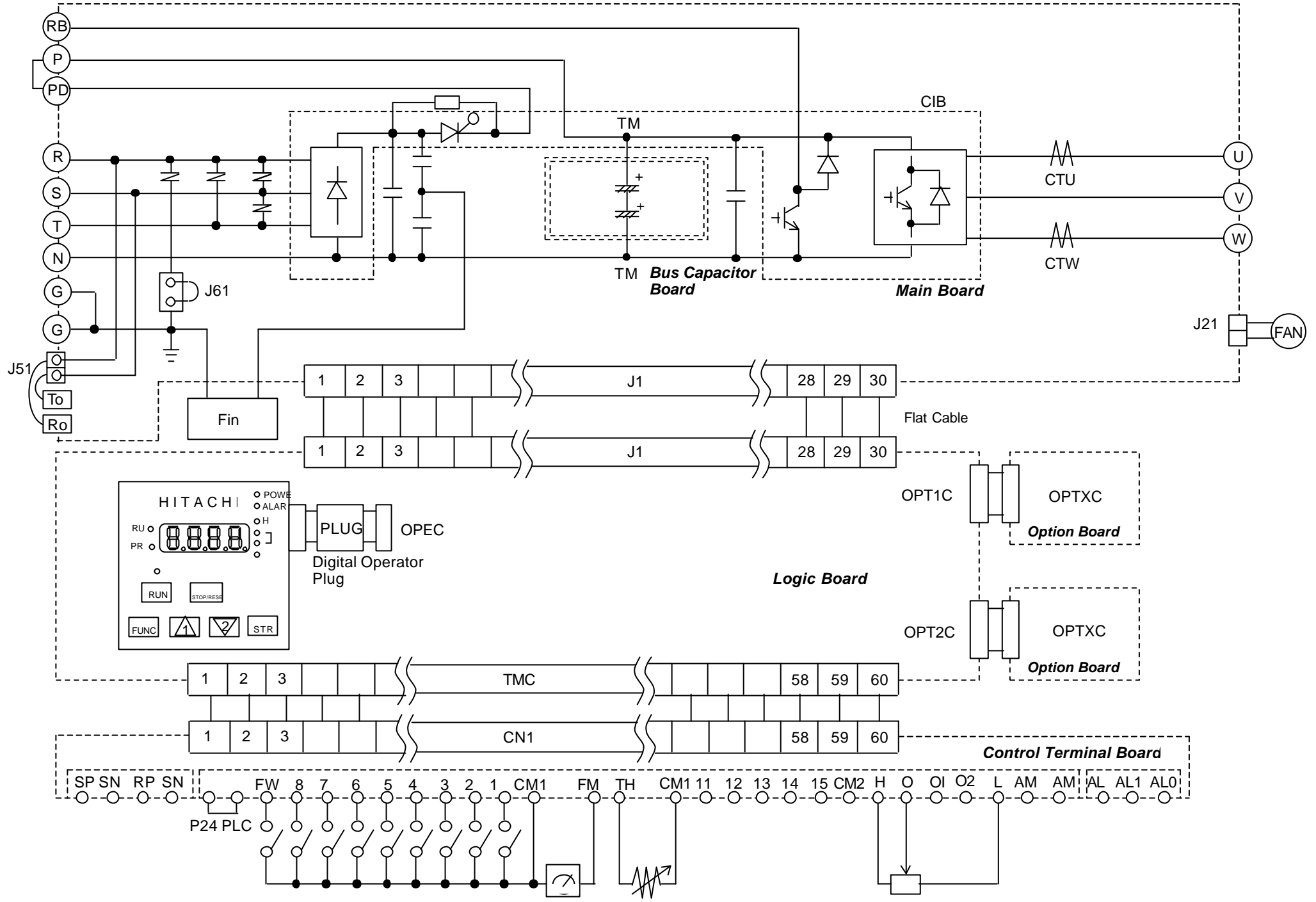

SJ300-015-055HF Circuit Diagram

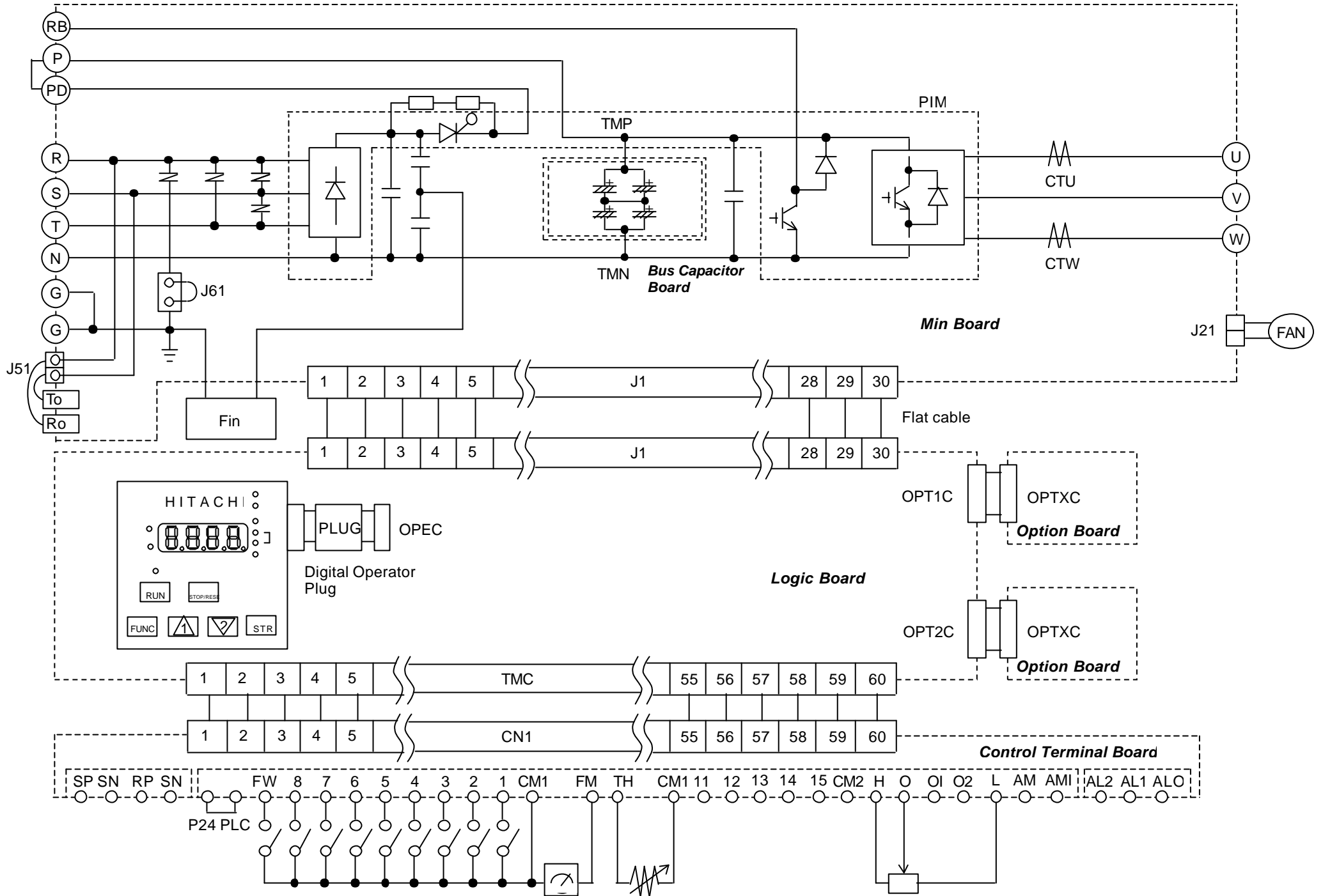

SJ300-075-110HF, L300P-110-150HFR Circuit Diagram

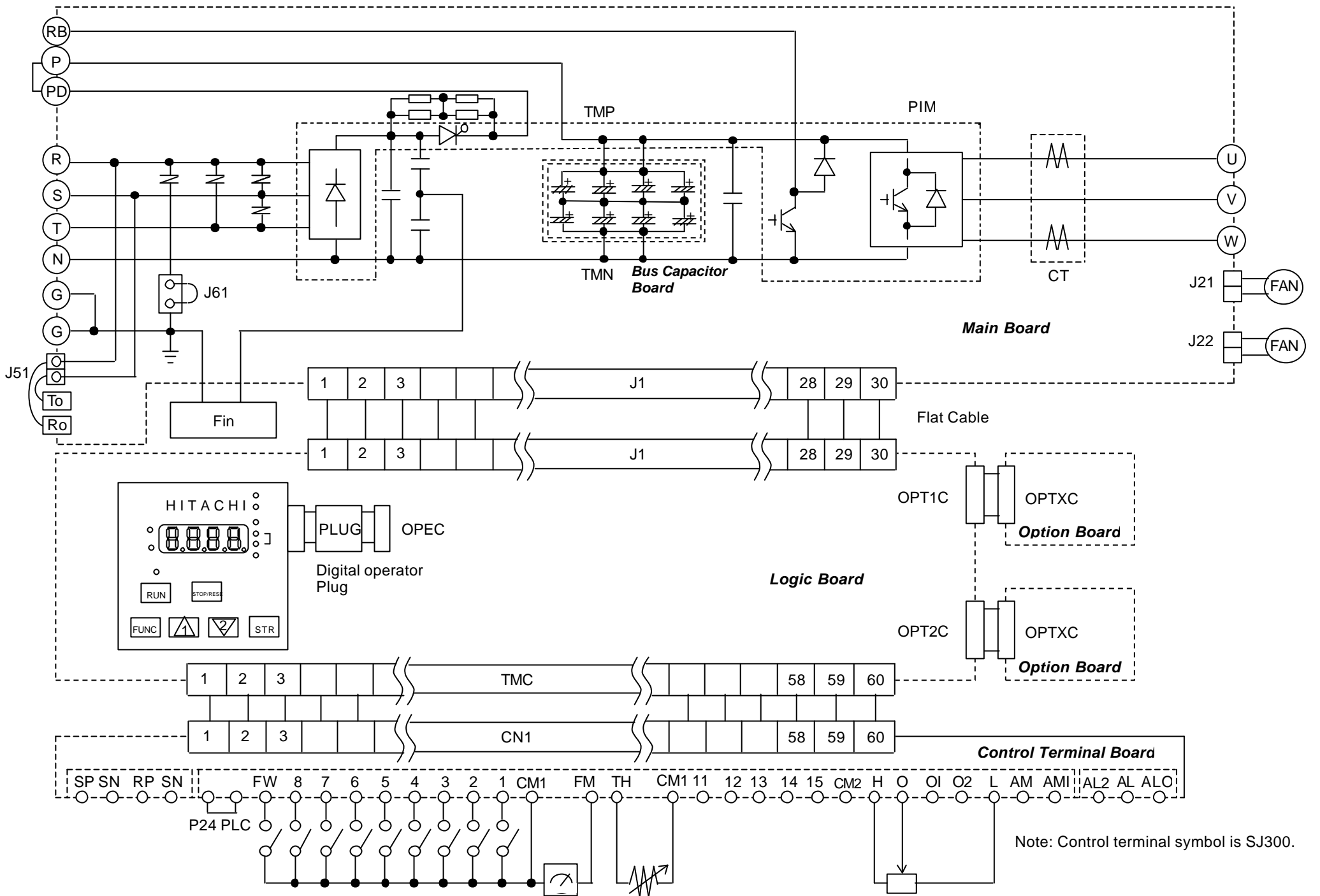

Note: Control terminal symbol is SJ300.

SJ300-150 - 220HF , L300P-185 - 300HFR Circuit Diagram

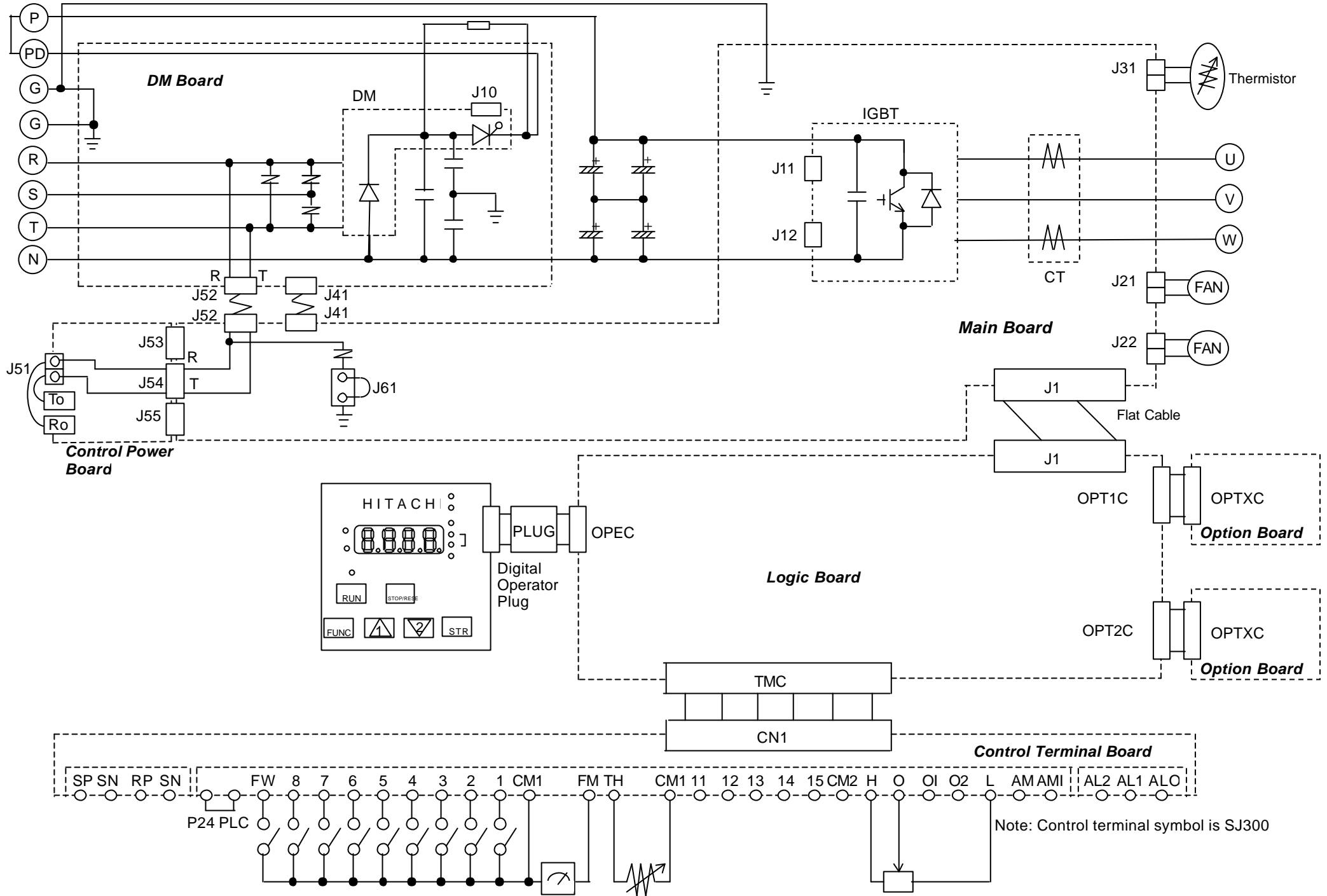

Note: Control terminal symbol is SJ300

SJ300-300HF , L300P-370HFR Circuit Diagram

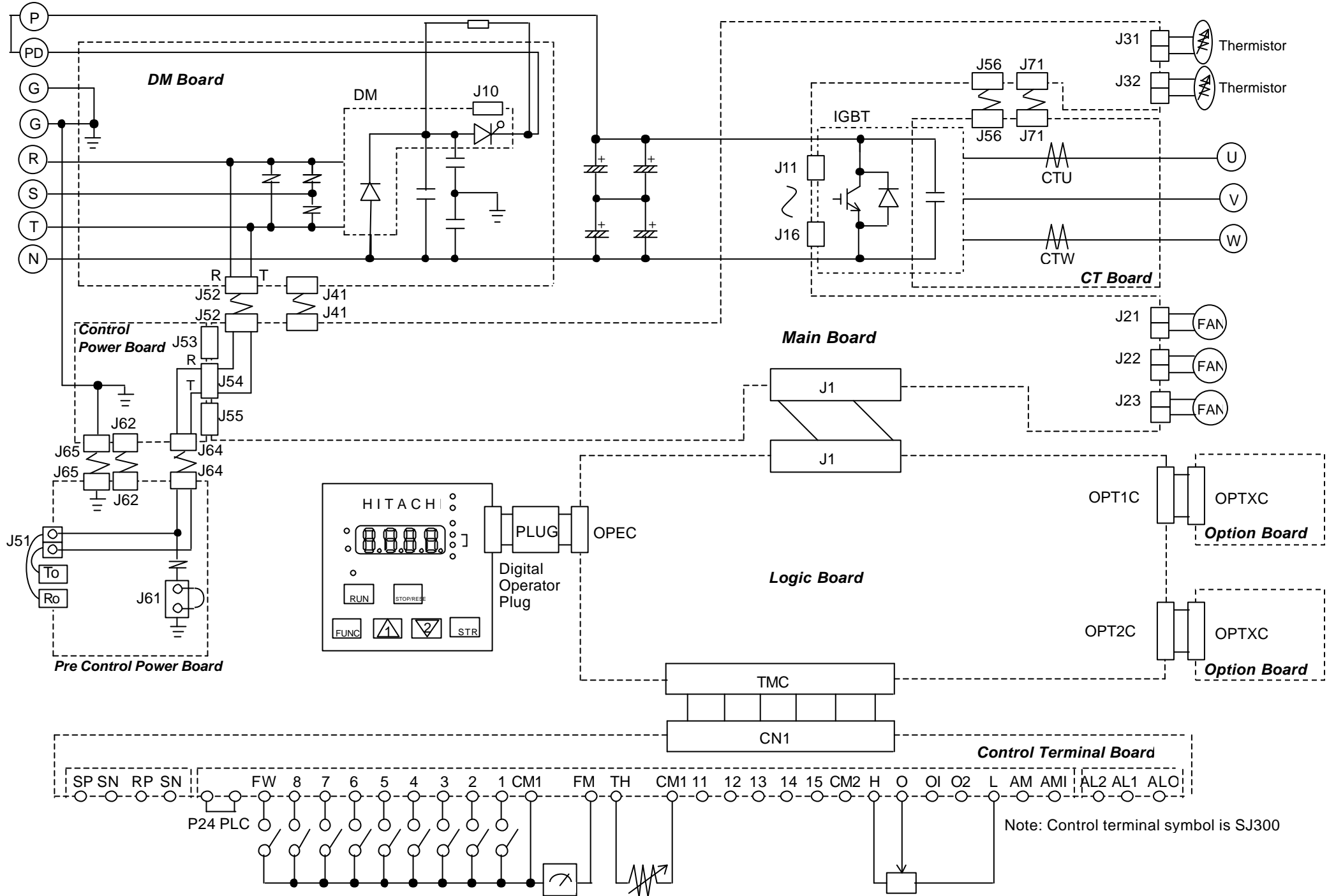

SJ300-370- 550HF,L300P-450-750HFR Circuit Diagram

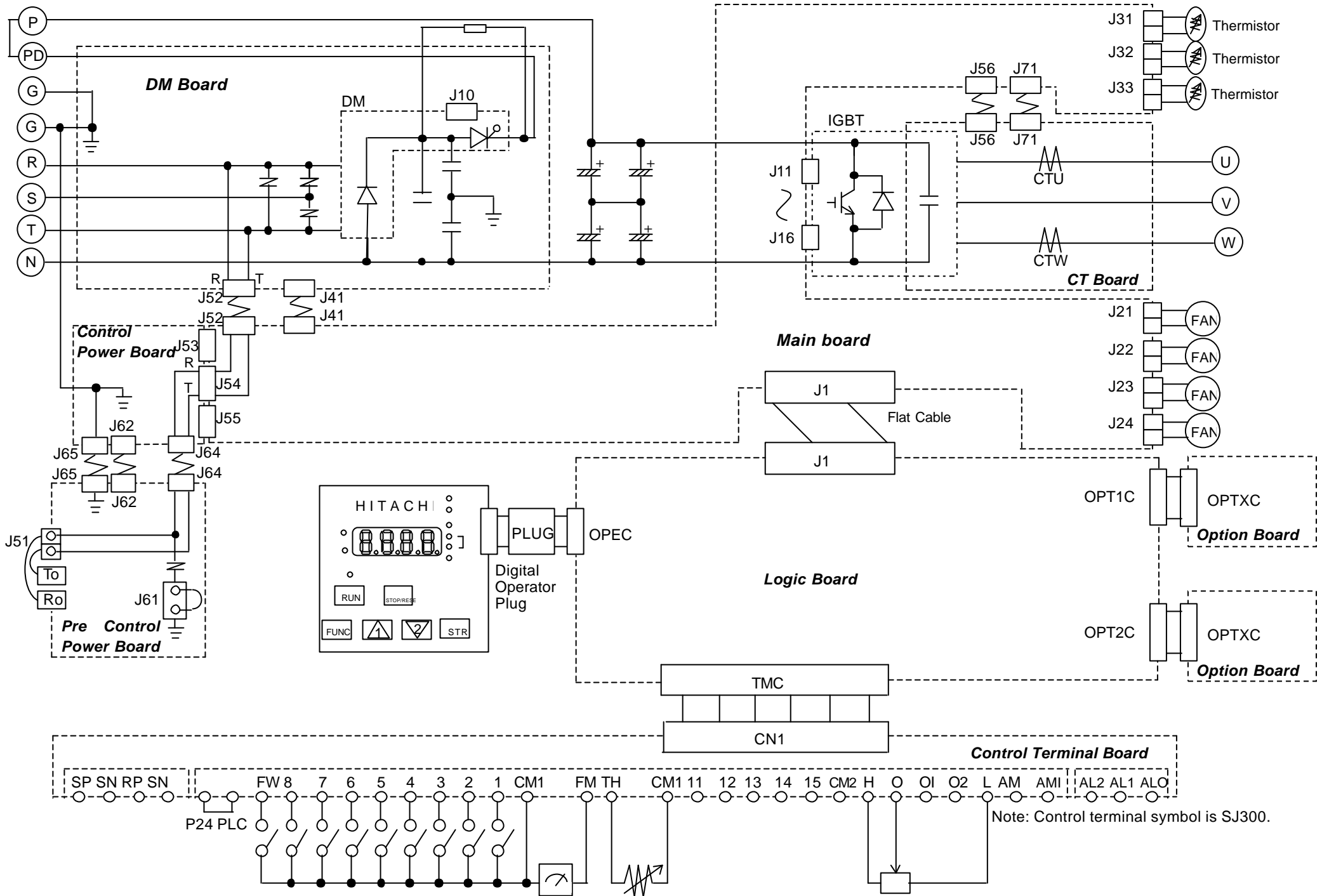

SJ300-750-1320HF , L300P-900-1320HFR Circuit Diagram

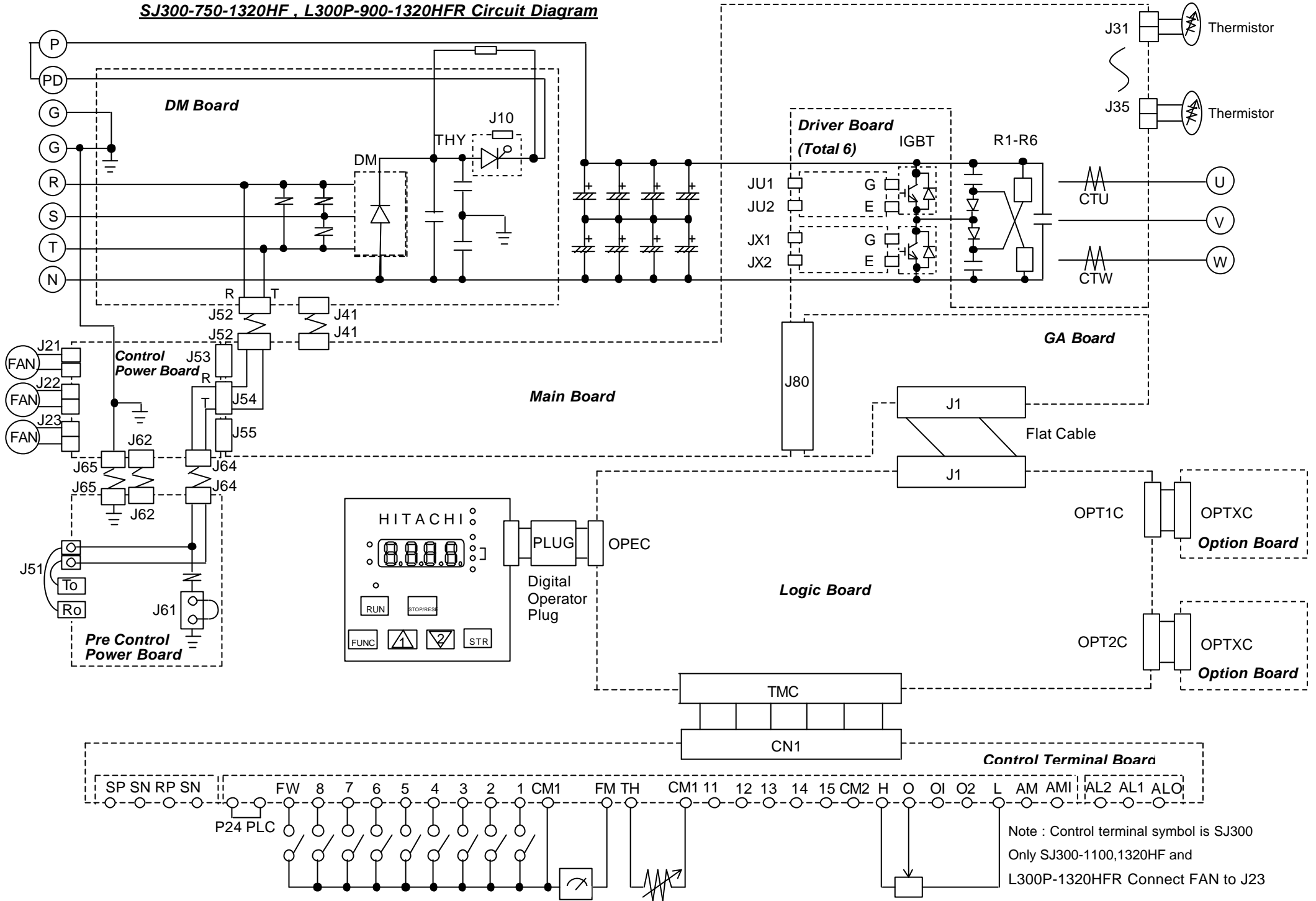

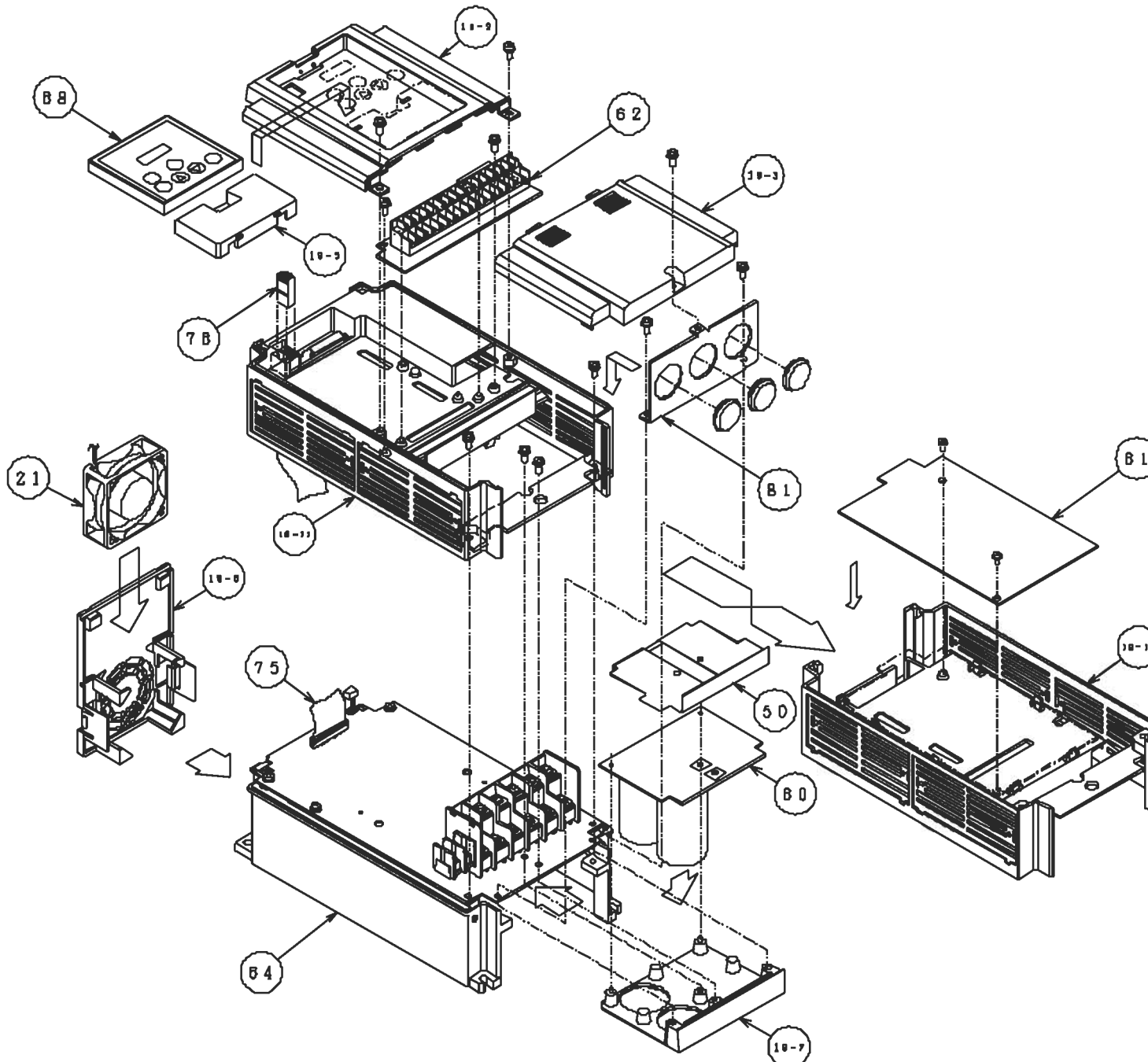

No.	Abbreviation	Name of parts	Quantity per unit
19-2	CV	Front cover	1
19-3	CV	Terminals cover	1
19-5	CV	Spacer cover	1
19-6	PUDO	Cooling fan attachment board	1
19-7	PL	DC bus capacitor attachment block	1
19-11	CV	Main body cover	1
21	FAN	Cooling fan	1
50	INS	Insulation board	1
60	P/SUB	DC bus capacitor PCB	1
61	P/L	Logic PCB	1
62	P/SUB	Central circuit terminals PCB	1
64	PCB	Main PCB with main body case	1
68	PANEL	Digital operator	1
75	WIRE	FFC	1
76	PLUG	Digital operator connection plug	1
81	PL	Wiring blind cover	1

DESIGN	N. HIROTA	CHKD BY	SH	SJ300-004-007LF/HF Structure diagram		NARAKIHO WORKS ENG. NO. 324 3T023505
CHKD	S. SERICUCHI					
APPD	L. TORASHIKI					

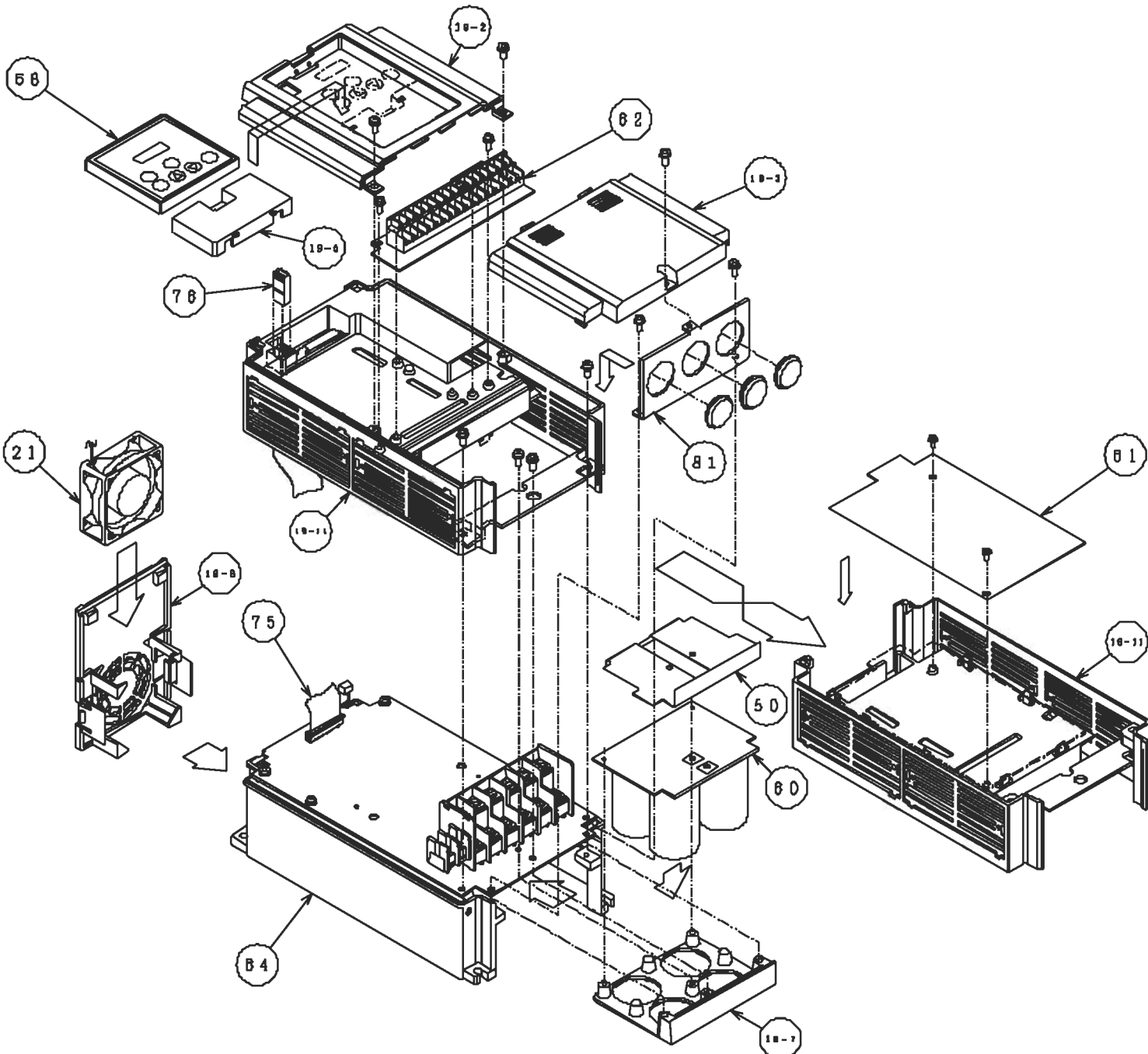

No.	Abbreviation	Name of parts	Quantity for 1 unit
19-2	CV	Front cover	1
19-3	CV	Terminals cover	1
19-4	CV	Spacer cover	1
19-6	FUDO	Cooling fan attachment board	1
19-7	PL	X br capacitor attachment board	1
19-11	CV	Main body cover	1
21	FAN	Cooling fan	1
50	INS	Insulation board	1
60	P/SUB	DC bus capacitor PCB	1
61	P/L	Logic PCB	1
62	P/SUB	Control circuit terminals PCB	1
64	PCB	Main PCB with main body case	1
68	PANEL	Digital operator	1
75	WIRE	FFC	1
76	PLUG	Digital operator connection plug	1
81	PL	Wiring blind cover	1

OWN	M. SIBUYA	200-01-11	SJ300-015~055LP Structure diagram
CHKD	S. SEKIGUCHI		
APPD	M. TOKASHIKI		

Hitachi, Ltd.
Tokyo, Japan

KARASHIMA WORKS INC. NO.
324 3T823583

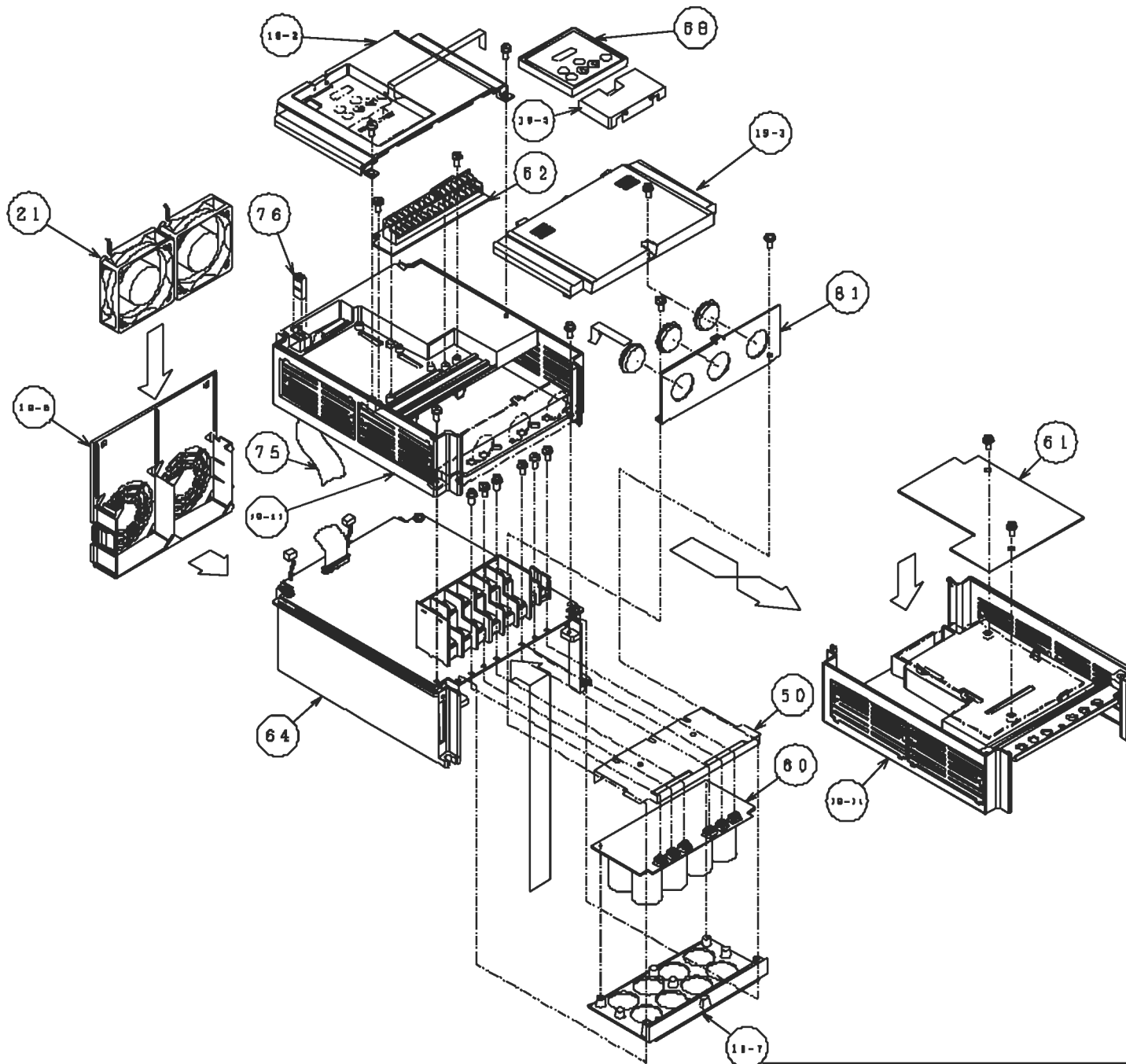

No.	Abbreviation	Name of parts	Quantity for 1 unit
18-2	CV	Front cover	1
18-3	CV	Terminals cover	1
18-5	CV	Spacer cover	1
18-6	FUDO	Cooling fan attachment board	1
18-7	PL	DC bus capacitor attachment block	1
18-11	CV	Main body cover	1
21	FAN	Cooling fan	2
50	INS	Insulation board	1
60	P/SUB	DC bus capacitor PCB	1
61	P/L	Logic PCB	1
62	P/SUB	Control circuit terminals PCB	1
64	PCB	Main PCB with main body case	1
68	PANEL	Digital operator	1
75	WIRE	FPC	1
76	PLUG	Digital operator connection plug	1
81	PL	Wiring blind cover	1

CHKD	M. HIRATA	2000 01-24
CHKD	S. SAKIGUCHI	..
APPD	M. TORASHIGE	..

SJ300-075-110LP/HP
Structure diagram

Hitachi, Ltd.
Tokyo, Japan

MARASHIMO WORKS DWG. NO.
324 3T823584

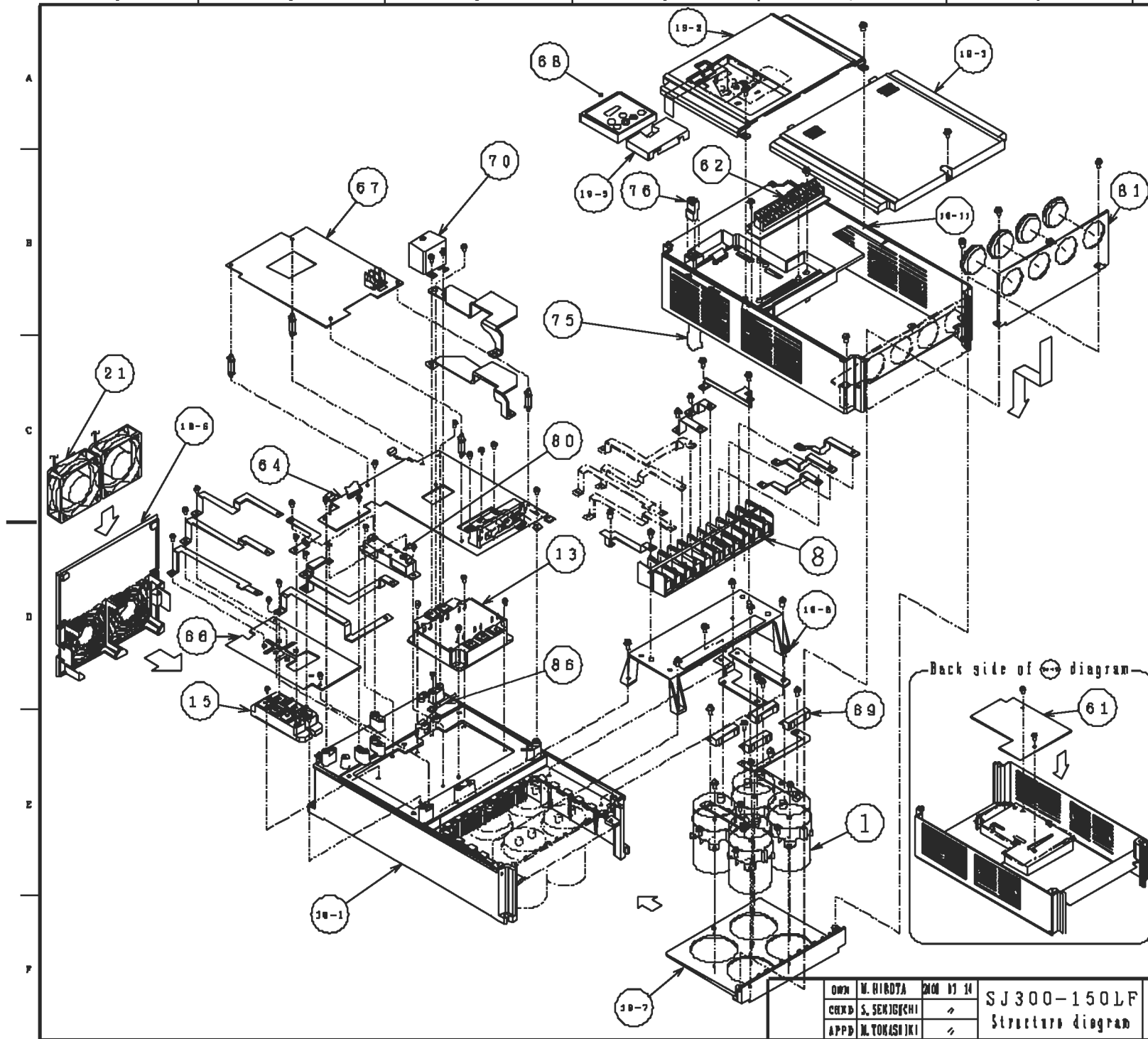

No.	Abbreviation	Name of parts	Quantity per 1 unit
1	CB	DC bus capacitor	4
8	T, BLK	Main circuit terminals	1
13	TRM	IGBT module	1
15	DM	Diode module	1
19-1	CS	Main body case	1
19-2	CV	Front cover	1
19-3	CV	Terminals cover	1
19-4	CV	Spacer cover	1
19-5	PVOD	Cooling fan attachment board	1
19-6	PL	DC bus capacitor attachment blind	1
19-7	BEO	Terminal attachment board	1
19-8	CV	Main body cover	1
21	FAN	Cooling fan	2
61	P/L	Logic PCB	1
62	P/SUB	Control circuit terminals PCB	1
64	PCB	Main PCB	1
66	PCB	DM PCB	1
67	PCB	Power source PCB	1
68	PANEL	Digital operator	1
69	RB	Balance resistor	4
70	CB	Snubber capacitor	1
75	WIRE	FPC	1
78	PLUG	Digital operator connection plug	1
80	RB	Current-limiting resistor	1
81	PL	Wiring blind cover	1
86	TRM	Thermistor	1

OWN M. HIRATA
 CHKD S. SENOYUCHI
 APPD N. YOKOSHIKI

DIM 11 14
 SJ300-150LF
 Structure diagram

Hitachi, Ltd.
 Tokyo, Japan

WARASHINO WORKS DIV. NO.
 324 3T823586

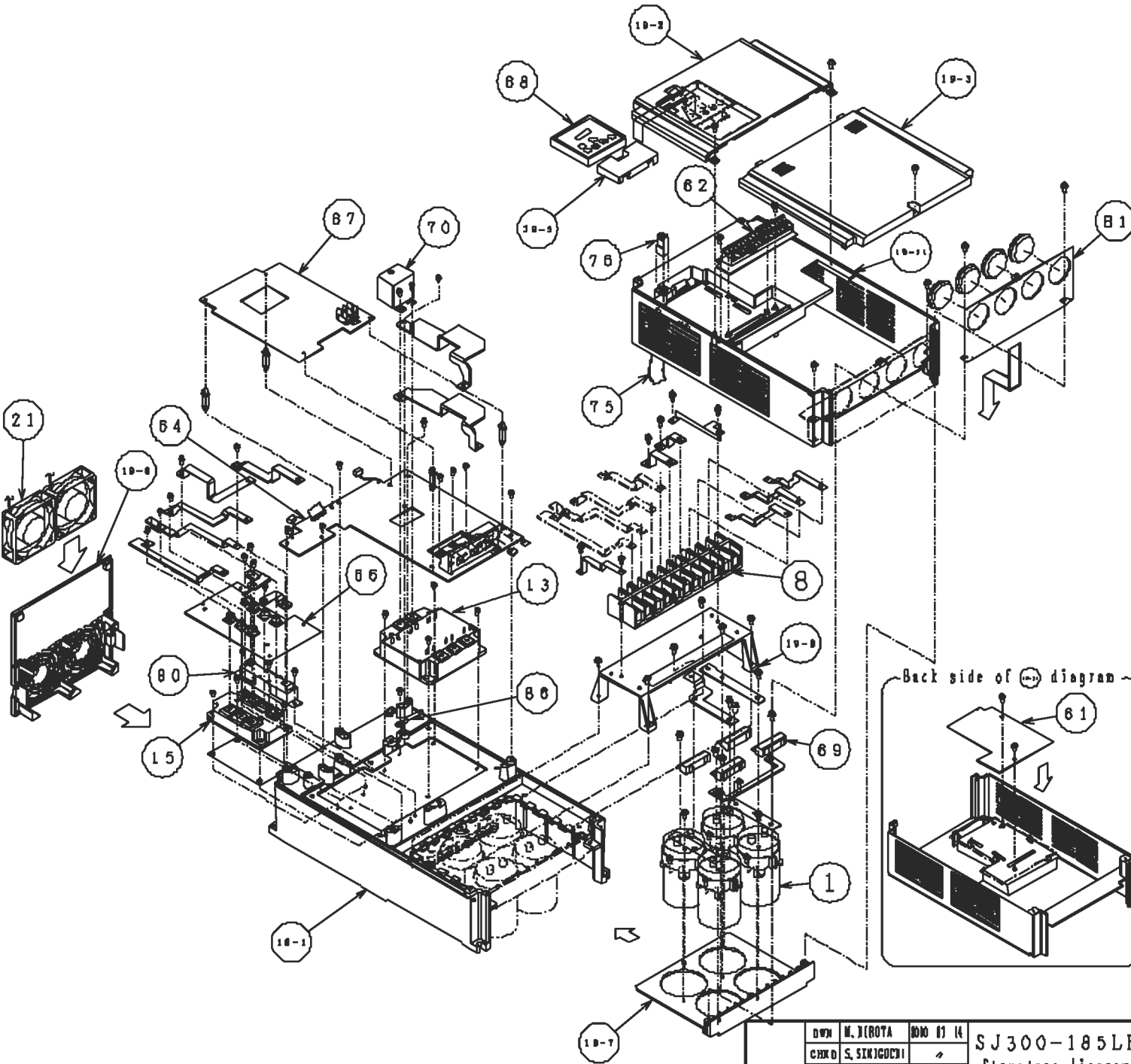

No.	Abbreviation	Name of parts	Quantity for 1 unit
1	CB	DC bus capacitor	4
8	T, BLK	Main circuit terminals	1
13	TRM	ICBT module	1
15	DM	Diode module	1
19-1	CS	Main body case	1
19-2	CV	Front cover	1
19-3	CV	Terminals cover	1
19-4	CV	Spacer cover	1
19-5	FJDO	Cooling fan attachment board	1
10-1	PL	Wiring capacitor attachment block	1
10-2	RED	Terminal attachment board	1
10-3	CV	Main body cover	1
21	FAN	Cooling fan	2
81	P/L	Logic PCB	1
82	P/SUB	Control circuit terminals PCB	1
64	PCB	Main PCB	1
68	PCB	DM PCB	1
67	PCB	Power source PCB	1
68	PANEL	Digital operator	1
68	RB	Balance resistor	4
70	CB	Subber capacitor	1
75	WIRE	FFC	1
76	PLUG	Digital operator connection plug	1
80	RS	Current-limiting resistor	1
81	PL	Wiring blind cover	1
86	TRM1	Thermistor	1

DWN M. YUROYA BDDO BT IA
 CHRD S. SAKIGUCHI
 APPD M. YOKASAKI

SJ300-185LF
 Structure diagram

Hitachi, Ltd.
 Tokyo, Japan

NAWASHINO WORKS DWG. NO.
 324 3T823587

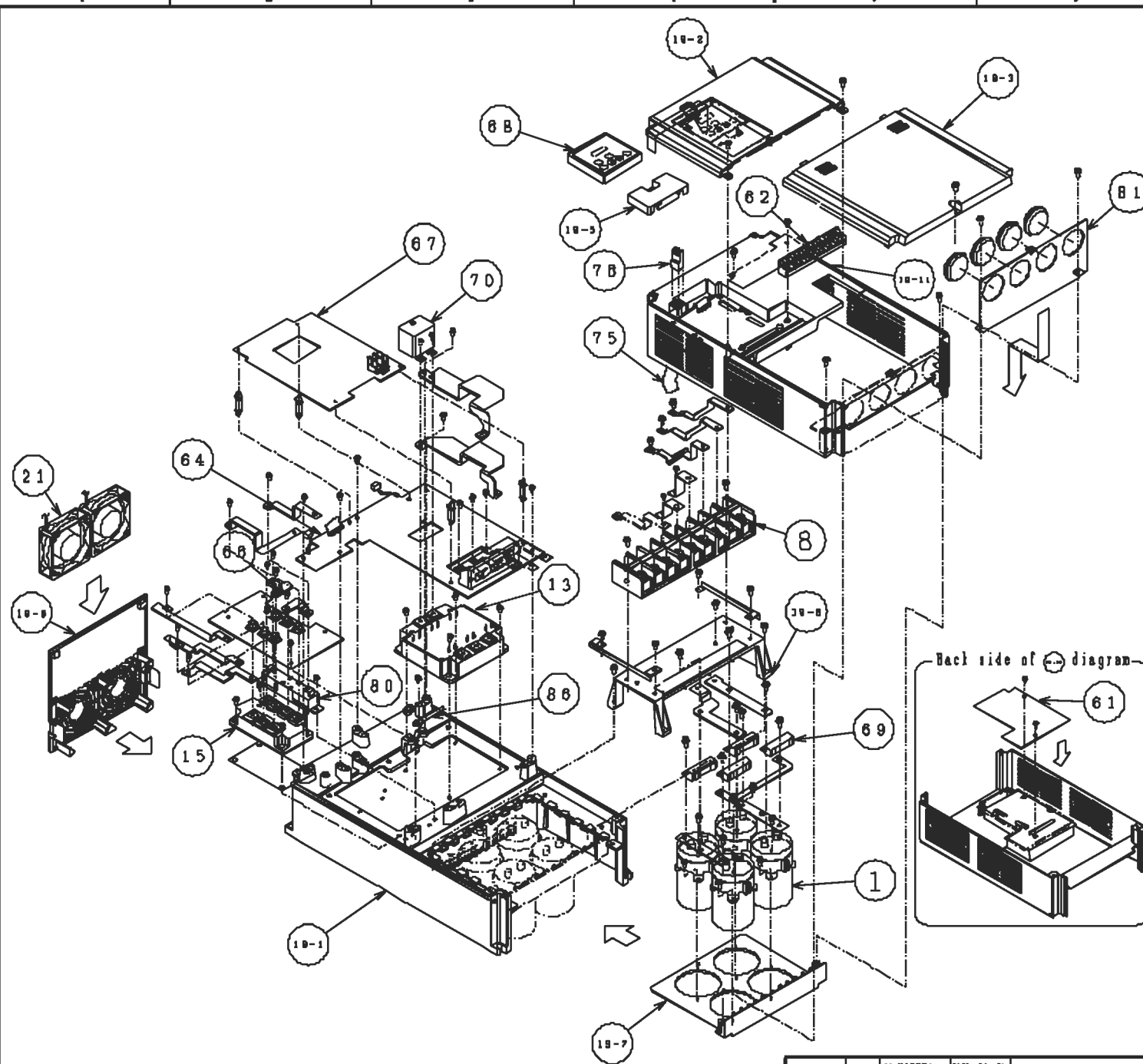

No.	Abbreviation	Name of parts	Quantity for 1 unit
1	CB	DC bus capacitor	4
8	T. BLK	Main circuit terminals	1
13	TRS	IGBT module	1
15	DM	Diode module	1
19-1	CS	Main body case	1
19-2	CV	Front cover	1
19-3	CV	Terminals cover	1
19-4	CV	Spacer cover	1
19-5	FUDO	Cooling fan attachment board	1
19-6	PL	DC bus capacitor attachment block	1
19-7	BED	Terminal attachment board	1
19-11	CV	Main body cover	1
21	FAN	Cooling fan	2
61	P/L	Logic PCB	1
62	P/SUB	Control circuit terminals PCB	1
64	PCB	Main PCB	1
66	PCB	DM PCB	1
67	PCB	Power source PCB	1
68	PANEL	Digital operator	1
69	RB	Balance resistor	4
70	CB	Sunbber capacitor	1
75	WIRE	FFC	1
76	PLUG	Digital operator connection plug	1
80	RS	Current-limiting resistor	1
81	PL	Wiring blind cover	1
86	TRMI	Thermistor	1

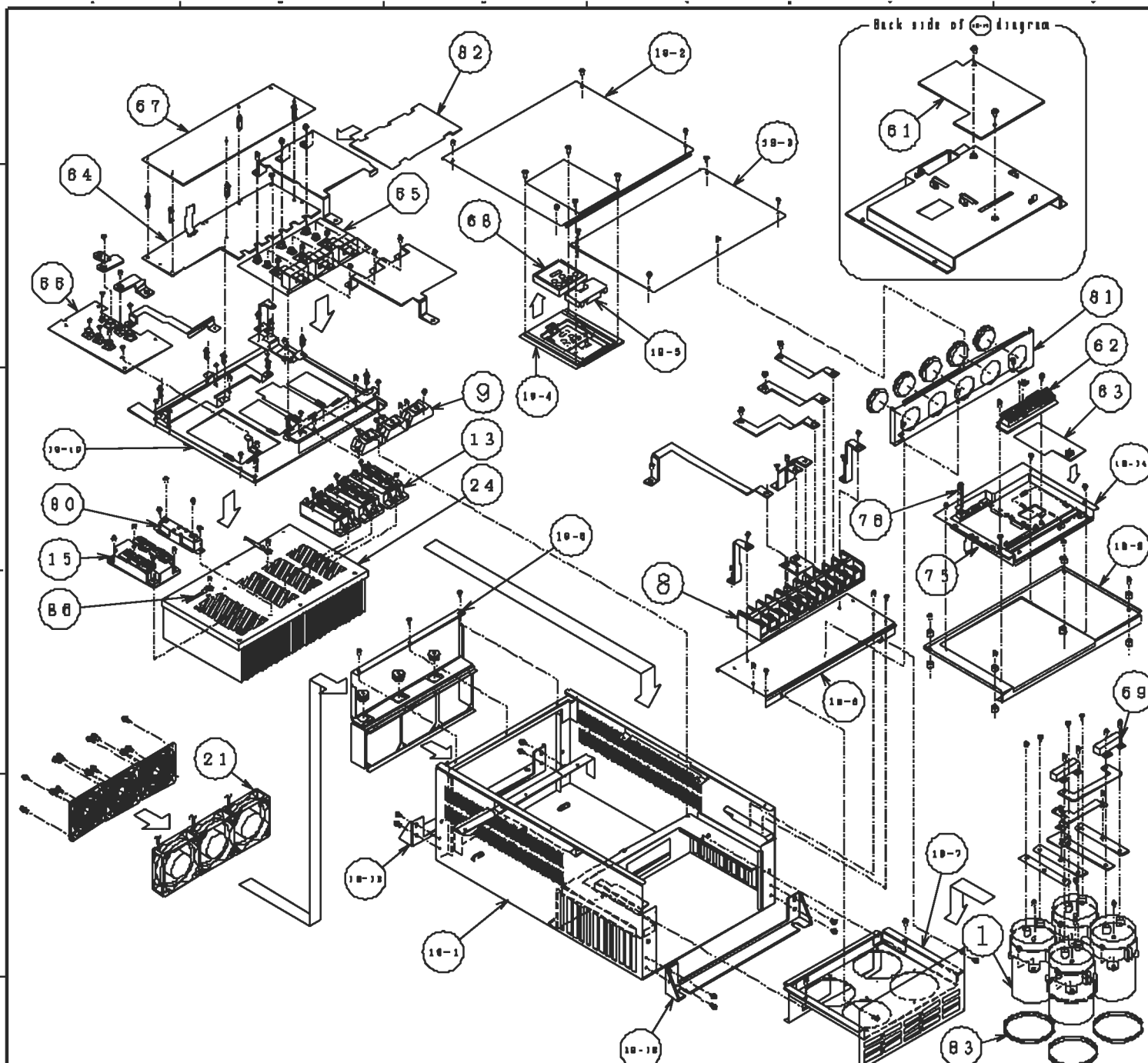

No.	Abbreviation	Name of parts	Quantity for 1 unit
1	CB	DC bus capacitor	4
8	T. BLK	Main circuit terminals	1
9	INS	Insulation terminal	3
13	TRS	IGBT module	3
15	DM	Diode module	1
19-1	CS	Main body case	1
19-1	CV	Front cover	1
19-1	CV	Terminals cover	1
19-1	CV	Digital operator attachment board	1
19-1	CV	Spacer cover	1
19-1	PUDD	Cooling fan attachment board	1
19-1	PL	DC bus capacitor attachment block	1
19-1	BED	Terminal attachment board	1
19-1	PL	Shielding board	1
11-10	PL	Parts attachment board	1
11-11	PL	Attachment board	1
11-12	PL	Attachment board	1
11-13	PL	Attachment board	1
11-14	PL	Control PCB attachment board	1
21	FAN	Cooling fan	3
24	FIN	Heat sink	1
81	P/L	Logic PCB	1
82	P/SUB	Control circuit terminals PCB	1
83	PCB	ROTD PCB	1
84	PCB	Main PCB	1
85	PCB	(CT/snubber PCB)	1
86	PCB	DM PCB	1
67	PCB	Power source PCB	1
68	PANEL	Digital operator	1
69	RB	Balance resistor	4
75	WIRE	PFC	1
78	PLUG	Digital operator connection plug	1
80	RS	Current-limiting resistor	1
81	PL	Wiring blind cover	1
82	PL	Busbar insulation board	1
83	SPACER	Spacer	4
88	TRMI	Thermistor	2

DWG V. HIRATA
 CHKD S. SAKIGUCHI
 APPD M. YOKASHIKI

SJ300-300LP
 Structure diagram

Hitachi Ltd.
 Tokyo Japan

NABASHINO WORKS BNG, FD,
 324 3T823589

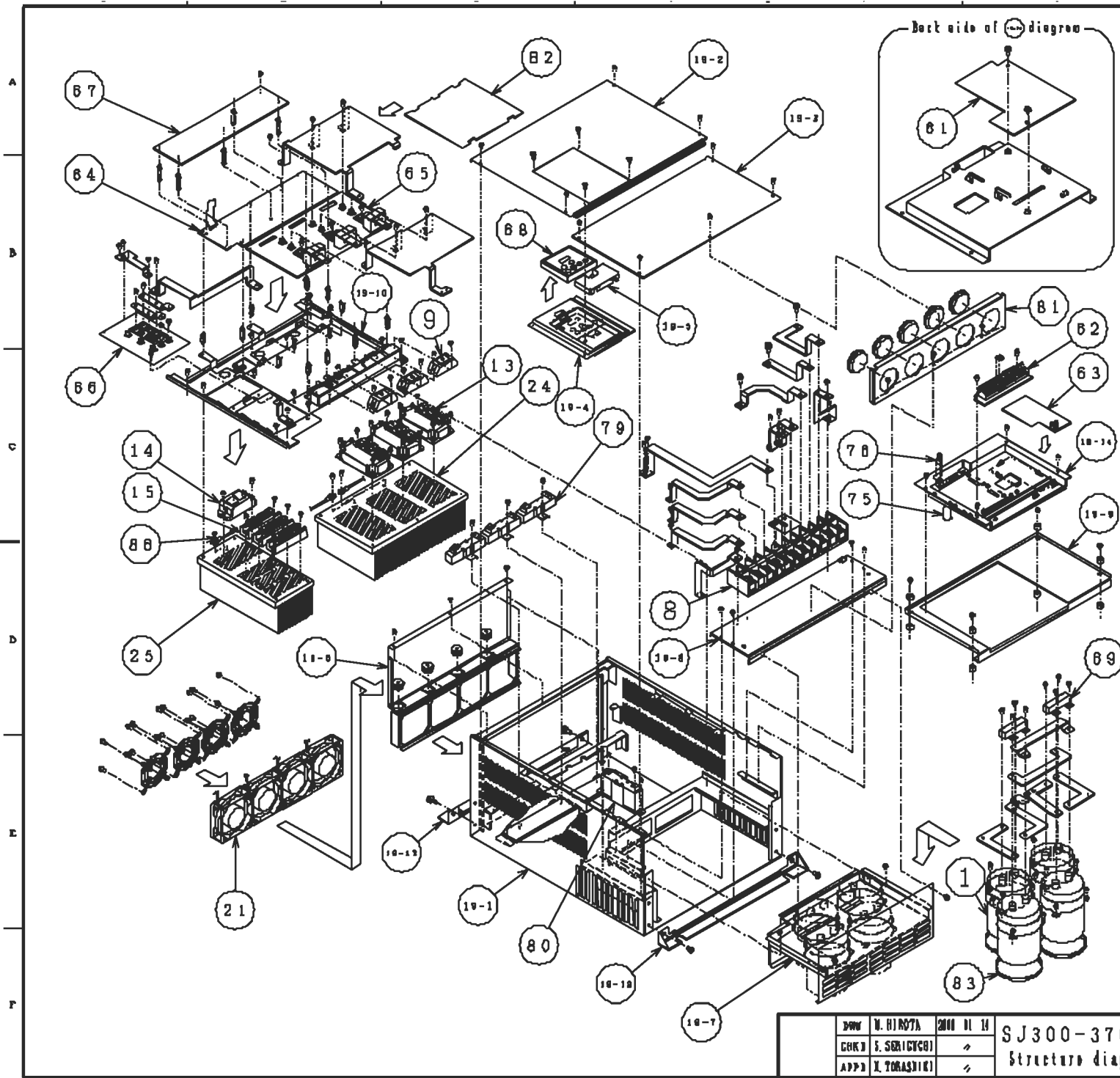

No.	Abbreviation	Name of parts	Quantity per Unit
1	CB	DC bus capacitor	4
8	7. BLK	Main circuit terminals	1
9	INS	Insulation terminal	3
13	TRS	IGBT module	3
14	THY	Thyristor module	1
15	DM	Diode module	3
19-1	CS	Main body case	1
19-2	CV	Front cover	1
19-3	CV	Terminals cover	1
19-4	CV	Digital operator attachment board	1
19-5	CV	Spacer cover	1
19-6	FUDO	Cooling fan attachment board	1
19-7	PL	DC bus capacitor attachment block	1
19-8	BED	Terminal attachment board	1
19-9	PL	Shielding board	1
19-10	PL	Parts attachment board	1
19-11	PL	Attachment board	1
19-12	PL	Attachment board	1
19-13	PL	Control PCB attachment board	1
20	PL	DM PEB attachment board	1
21	FAN	Cooling fan	4
24	FIN	Heat sink	1
25	FIN	Heat sink	1
81	P/L	Logic PCB	1
82	P/SUB	Control circuit terminals PCB	1
83	PCB	ROTO PCB	1
84	PCB	Main PCB	1
85	PCB	(GT/snubber PCB)	1
86	PCB	DM PCB	1
87	PCB	Power source PCB	1
88	PANEL	Digital operator	1
89	RB	Balance resistor	4
75	WIRE	FPC	1
76	PLUG	Digital operator connection plug	1
79	R1~R3	Snubber resistor	3
80	RS	Current-limiting resistor	1
81	PL	Wiring blind cover	1
82	PL	Busbar insulation board	1
83	SPACER	Spacer	4
86	TRM	Thermistor	3

DWG	N. HIRATA	2008.01.11	SJ300-370 L.F Structure diagram	 Hitachi, Ltd. Tokyo, Japan	NARASAKI WORKS INC. NO. 324 3T823590
CHKD	S. SAKITSUBO	✓			
APPD	X. TORASHIIE	✓			

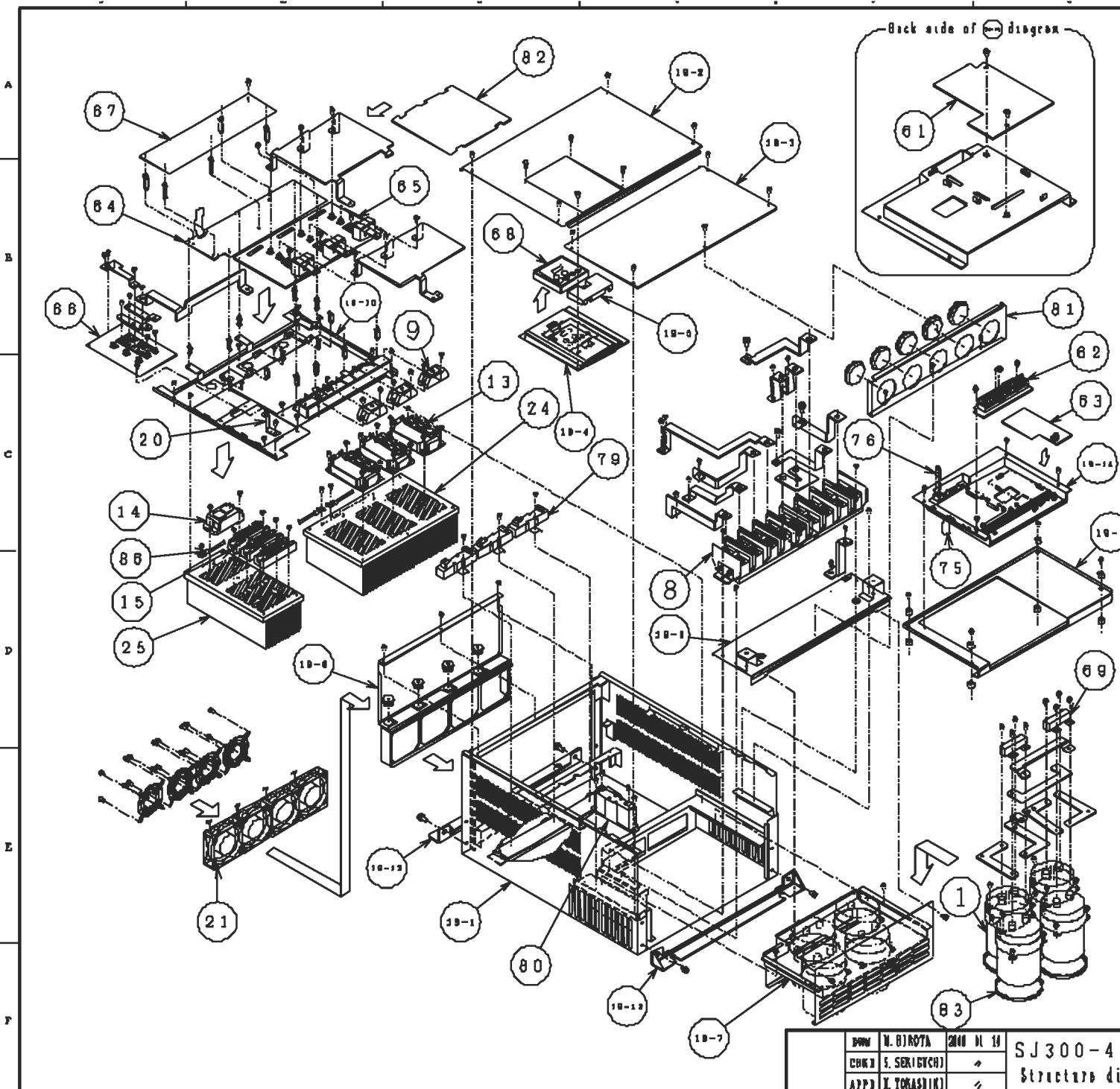

No.	Abbreviation	Name of parts	Quantity for 1 unit
1	CB	DC bus capacitor	4
8	T, BLK	Main circuit terminals	1
9	INS	Insulation terminal	3
13	TR3	IGBT module	3
14	TRX	Thyristor module	1
15	DM	Diode module	3
19_1	CS	Main body case	1
19_2	CV	Front cover	1
19_3	CV	Terminals cover	1
19_4	CV	Digital operator attachment board	1
19_5	CV	Spacer cover	1
19_6	PVDO	Cooling fan attachment board	1
19_7	PL	DC bus capacitor attachment block	1
19_8	BBD	Terminal attachment board	1
19_9	PL	Shielding board	1
19_10	PL	Parts attachment board	1
19_11	PL	Attachment board	1
19_12	PL	Attachment board	1
19_13	PL	Control PCB attachment board	1
20	PL	DM PCB attachment board	1
21	FAN	Cooling fan	4
24	FIN	Heat sink	1
25	FIN	Heat sink	1
61	P/L	Logic PCB	1
62	P/SUB	Control circuit terminals PCB	1
63	PCB	RDTO PCB	1
64	PCB	Main PCB	1
65	PCB	(CT/snubber PCB)	1
66	PCB	DM PCB	1
67	PCB	Power source PCB	1
68	PANEL	Digital operator	1
69	RB	Balance resistor	4
75	WIRE	FFC	1
76	PLUG	Digital operator connection plug	1
79	R1~R3	Snubber resistor	3
80	RS	Current-limiting resistor	1
81	PL	Wiring blind cover	1
82	PL	Busbar insulation board	1
83	SPACER	Spacer	4
86	TRM1	Thermistor	3

DRW	N. OJICHTA	2008.11.14	SJ300-450LF Structure diagram	Hitachi, Ltd. Tokyo, Japan	HATAGAKIHO WORKS CO., NO. 324 3T823591
CHKD	S. SAKIGUCHI				
APPD	K. TAKASHIKI				

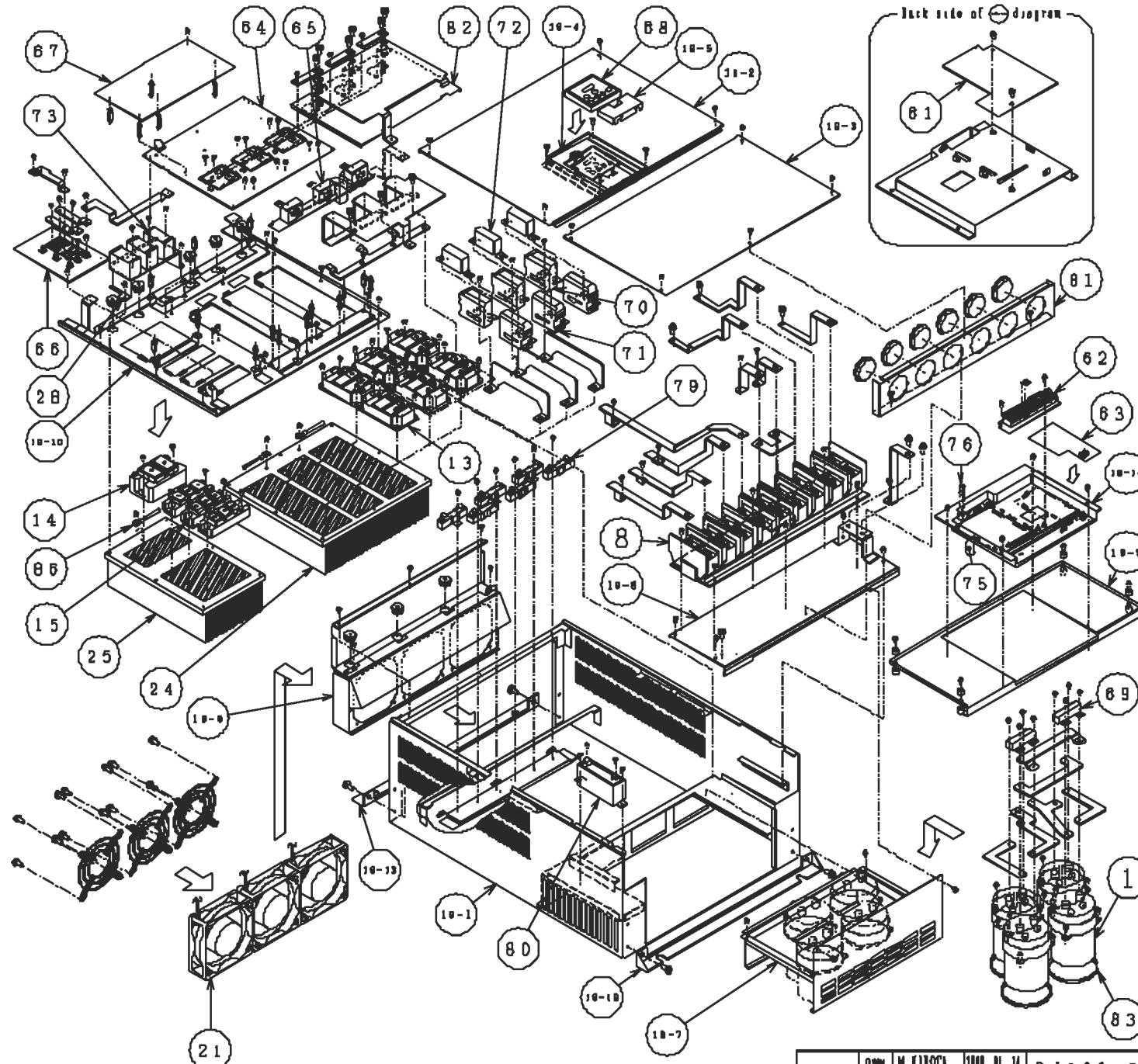

No.	Abbreviation	Name of parts	Quantity for 1 set
1	CB	DC bus capacitor	4
8	T, BLK	Main circuit terminals	1
13	TRS	IGBT module	6
14	THY	Thyristor module	1
15	DM	Diode module	3
18-1	CS	Main body case	1
18-2	CV	Front cover	1
18-3	CV	Terminals cover	1
18-4	CV	Digital operator attachment board	1
18-5	CV	Spacer cover	1
18-6	PCDD	Cooling fan attachment board	1
18-7	PL	DC bus capacitor attachment block	1
18-8	BED	Terminal attachment board	1
18-9	PL	Shielding board	1
18-10	PL	Parts attachment board	1
18-11	PL	Attachment board	1
18-12	PL	Attachment board	1
18-13	PL	Control PCB attachment board	1
21	FAN	Cooling fan	3
24	FIN	Heat sink	1
25	FIN	Heat sink	1
28	PL	Snubber capacitor attachment board	1
81	P/L	Logic PCB	1
62	P/SVB	Control circuit terminals PCB	1
63	PCB	ROTO PCB	1
64	PCB	Main PCB	1
65	PCB	(CT/snubber PCB)	1
66	PCB	DM PCB	1
67	PCB	Power source PCB	1
68	PANEL	Digital operator	1
89	RB	Balance resistor	2
70	Cl-C3	Snubber capacitor	3
71	Cl-C3	Snubber capacitor	3
72	Cl-C3	Snubber capacitor	3
73	Cl-C3	Snubber capacitor	3
75	WIRE	FFC	1
76	PLUG	Digital operator connection plug	1
79	R1-R6	Snubber resistor	6
80	RS	Current-limiting resistor	1
81	PL	Wiring blind cover	1
82	PL	Busbar insulation board	1
83	SPACER	Spacer	4
86	TRM1	Thermistor	3

OWN M. KUROKI 1988 DL 31
 CHOD S. SEKIGUCHI
 APPD M. YOKASAKI

SJ300-550LF
 Structure diagram

Hitachi, Ltd.
 Tokyo, Japan

MARASHINO WORKS BNG, NO.
 324 3T823592

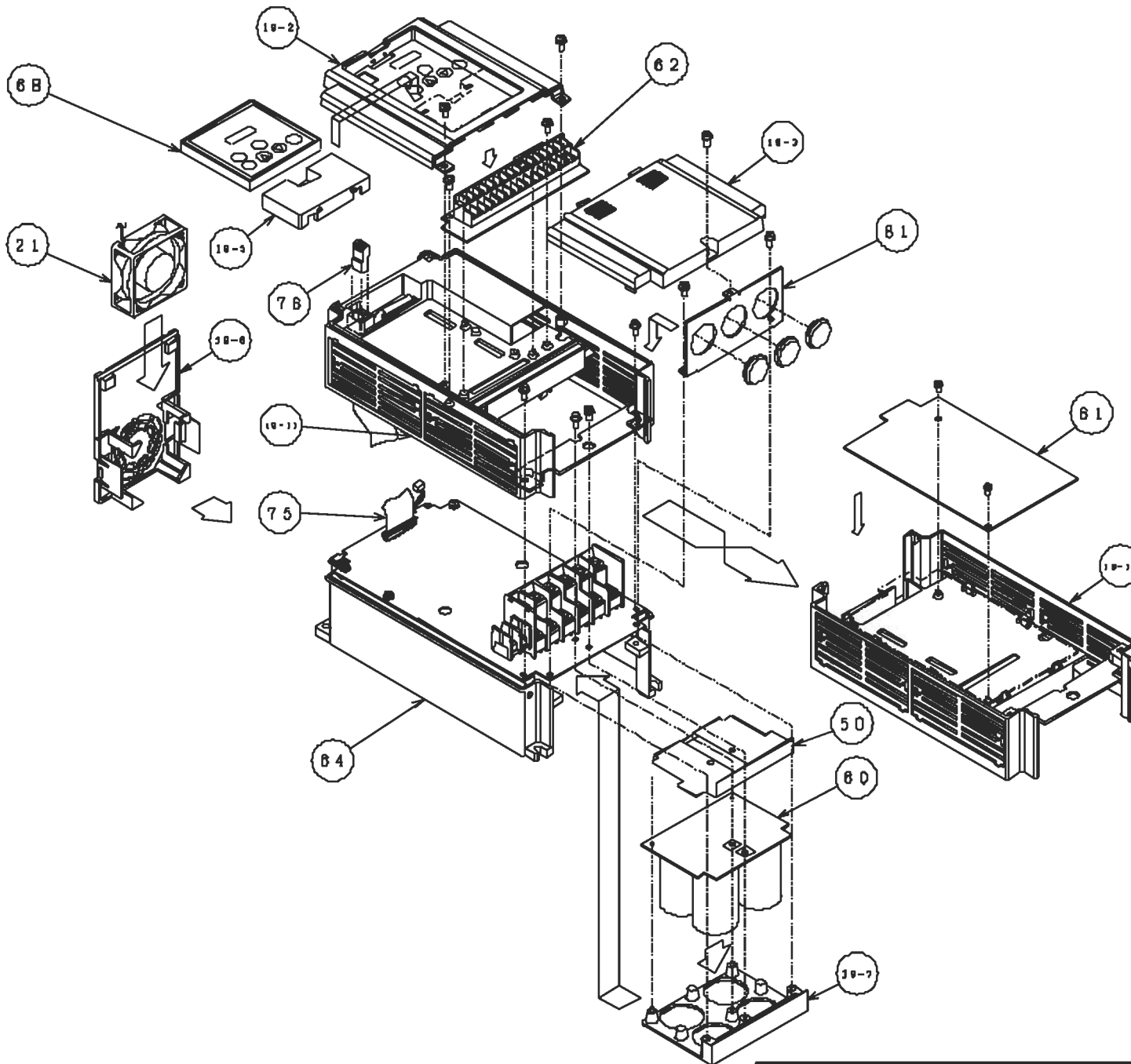

No.	Abbreviation	Name of parts	Quantity per Unit
19-2	CV	Front cover	1
19-3	CV	Terminals cover	1
19-4	CV	Spacer cover	1
19-5	FVDO	Cooling fan attachment board	1
19-6	PL	DC bus capacitor attachment block	1
19-11	CV	Main body cover	1
21	FAN	Cooling fan	1
50	INS	Insulation board	1
60	P/SUB	DC bus capacitor PCB	1
61	P/L	Logic PCB	1
62	P/SUB	Control circuit terminals PCB	1
64	PCB	Main PCB with main body case	1
68	PANEL	Digital operator	1
75	WIRE	FFC	1
76	PLUG	Digital operator connection plug	1
81	PL	Wiring blind cover	1

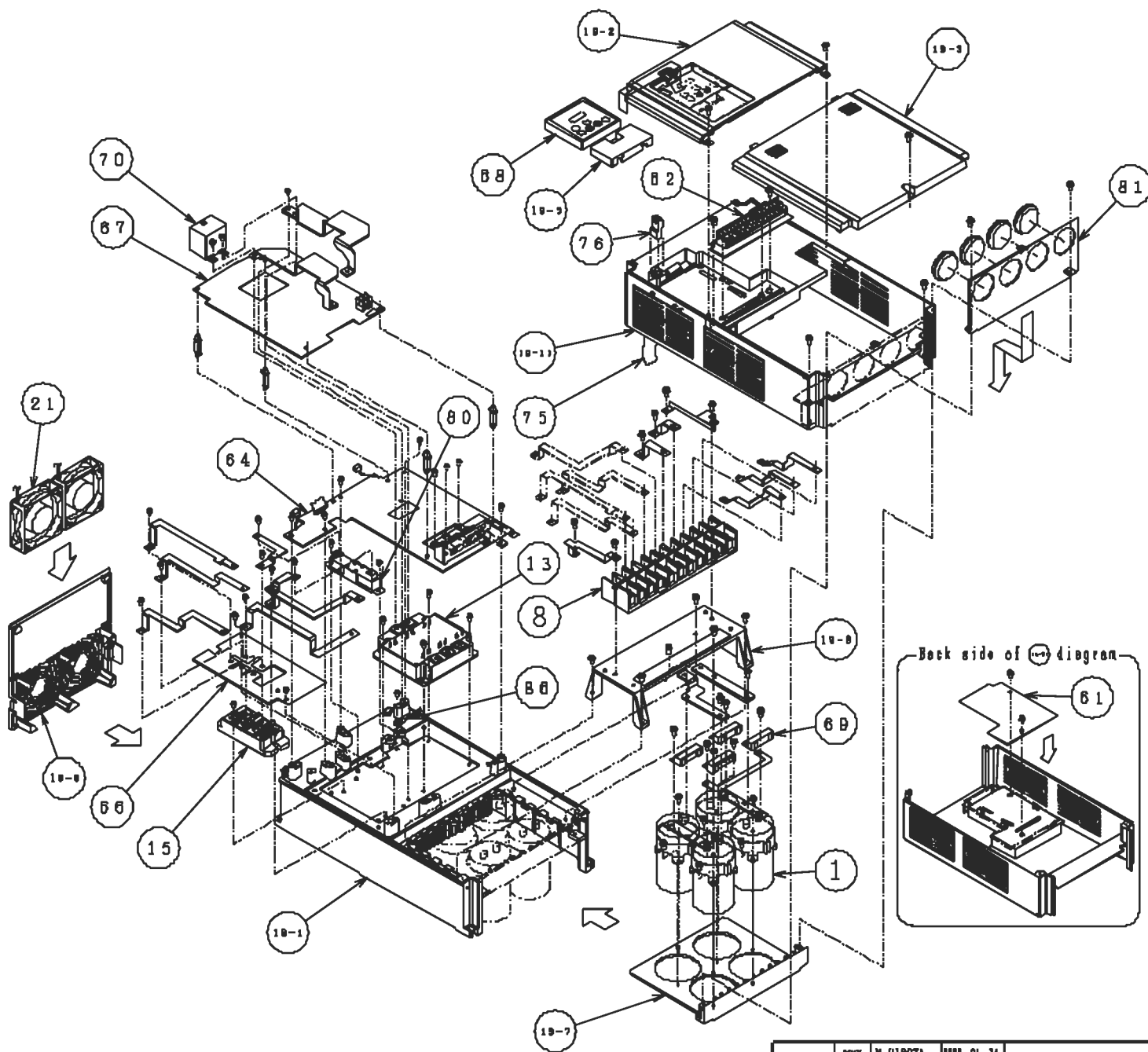

No.	Abbreviation	Name of parts	Quantity per unit
1	CB	DC bus capacitor	4
8	T, BLK	Main circuit terminals	1
13	TRS	IGBT module	1
15	DM	Diode module	1
19-1	CS	Main body case	1
19-2	CV	Front cover	1
19-3	CV	Terminals cover	1
19-4	CV	Spacer cover	1
19-5	FVDO	Cooling fan attachment board	1
19-6	PL	DC bus capacitor attachment block	1
19-7	BED	Terminal attachment board	1
19-11	CV	Main body cover	1
21	FAN	Cooling fan	2
61	P/L	Logic PCB	1
62	P/SUB	Control circuit terminal PCB	1
64	PCB	Main PCB	1
66	PCB	DM PCB	1
67	PCB	Power source PCB	1
68	PANEL	Digital operator	1
69	RB	Balance resistor	4
70	CB	Sunbber capacitor	1
75	WIRE	FFC	1
76	PLUG	Digital operator connection plug	1
80	RS	Current-limiting resistor	1
81	PL	Wiring blind cover	1
86	TRMI	Thermistor	1

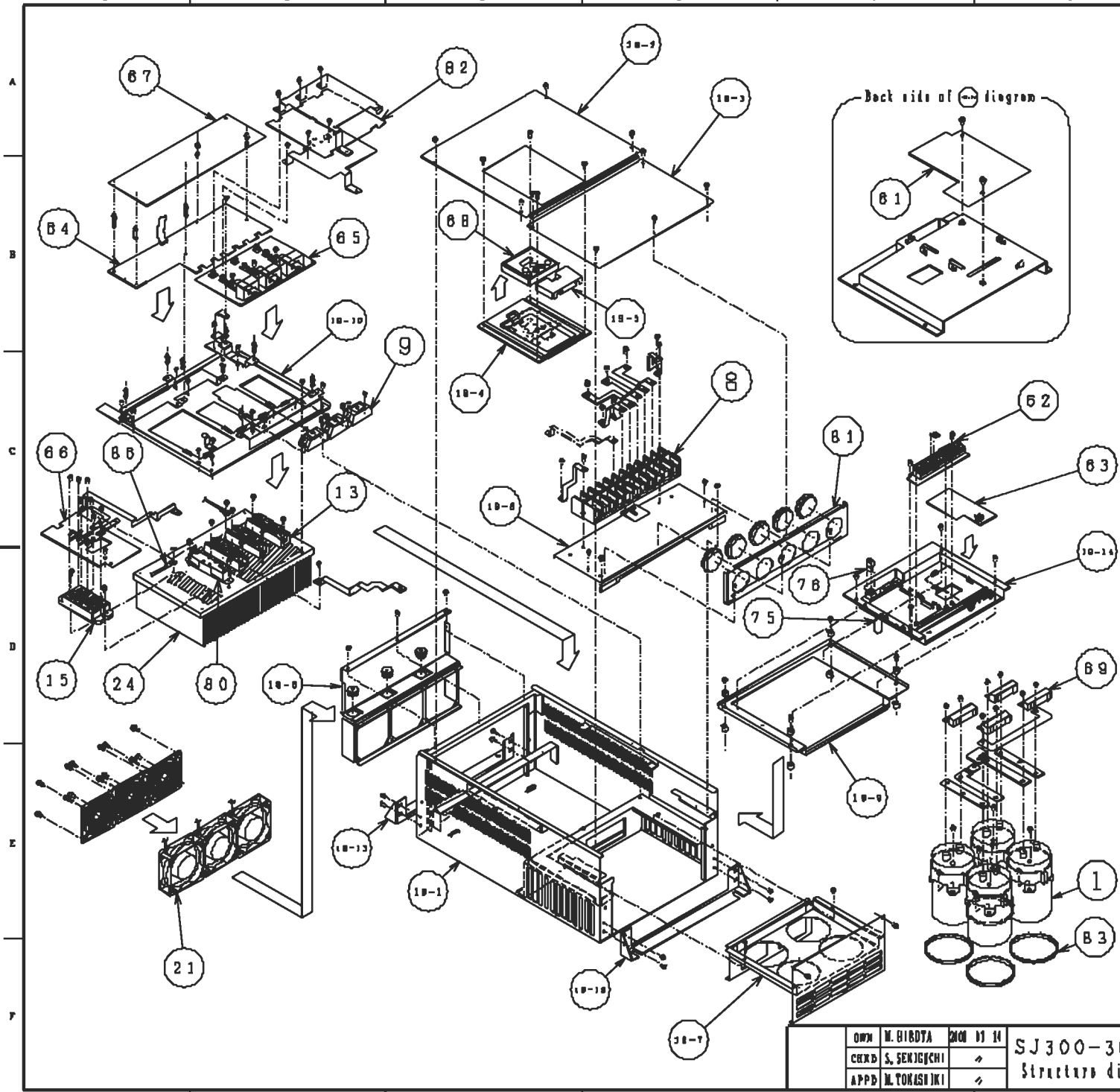

No.	Abbreviation	Name of parts	Quantity for 1 unit
1	CB	DC bus capacitor	4
8	T. BLK	Main circuit terminals	1
9	INS	Insulation terminal	3
13	TR3	IGBT module	3
15	DM	Diode module	1
18-1	CS	Main body case	1
18-2	CV	Front cover	1
18-3	CV	Terminals cover	1
18-4	CV	Digital operator attachment board	1
18-5	CV	Spacer cover	1
18-6	FUDO	Cooling fan attachment board	1
18-7	PL	DC bus capacitor attachment block	1
18-8	BED	Terminal attachment board	1
18-9	PL	Shielding board	1
18-10	PL	Parts attachment board	1
18-11	PL	Attachment board	1
18-12	PL	Attachment board	1
18-13	PL	Control PCB attachment board	1
21	FAN	Cooling fan	3
24	FIN	Heat sink	1
61	P/L	Logic PCB	1
62	P/SUB	Control circuit terminals PCB	1
63	PCB	ROTC PCB	1
64	PCB	Main PCB	1
65	PCB	(CT/snubber PCB)	1
66	PCB	DM PCB	1
67	PCB	Power source PCB	1
68	PANEL	Digital operator	1
69	RB	Balance resistor	4
75	WIRE	FFC	1
76	PLUG	Digital operator connection plug	1
80	RS	Current-limiting resistor	1
81	PL	Wiring blind cover	1
82	PL	Busbar insulation board	1
83	SPACER	Spacer	4
86	TRM	Thermistor	2

OWN	W. HIROTA	CHK BY	14	SJ300-300HF Structure diagram		NARASHINO WORKS DIV. NO. 324 3T823595
CHKD	S. SENOJICHI					
APPD	M. TOKASTIKI					

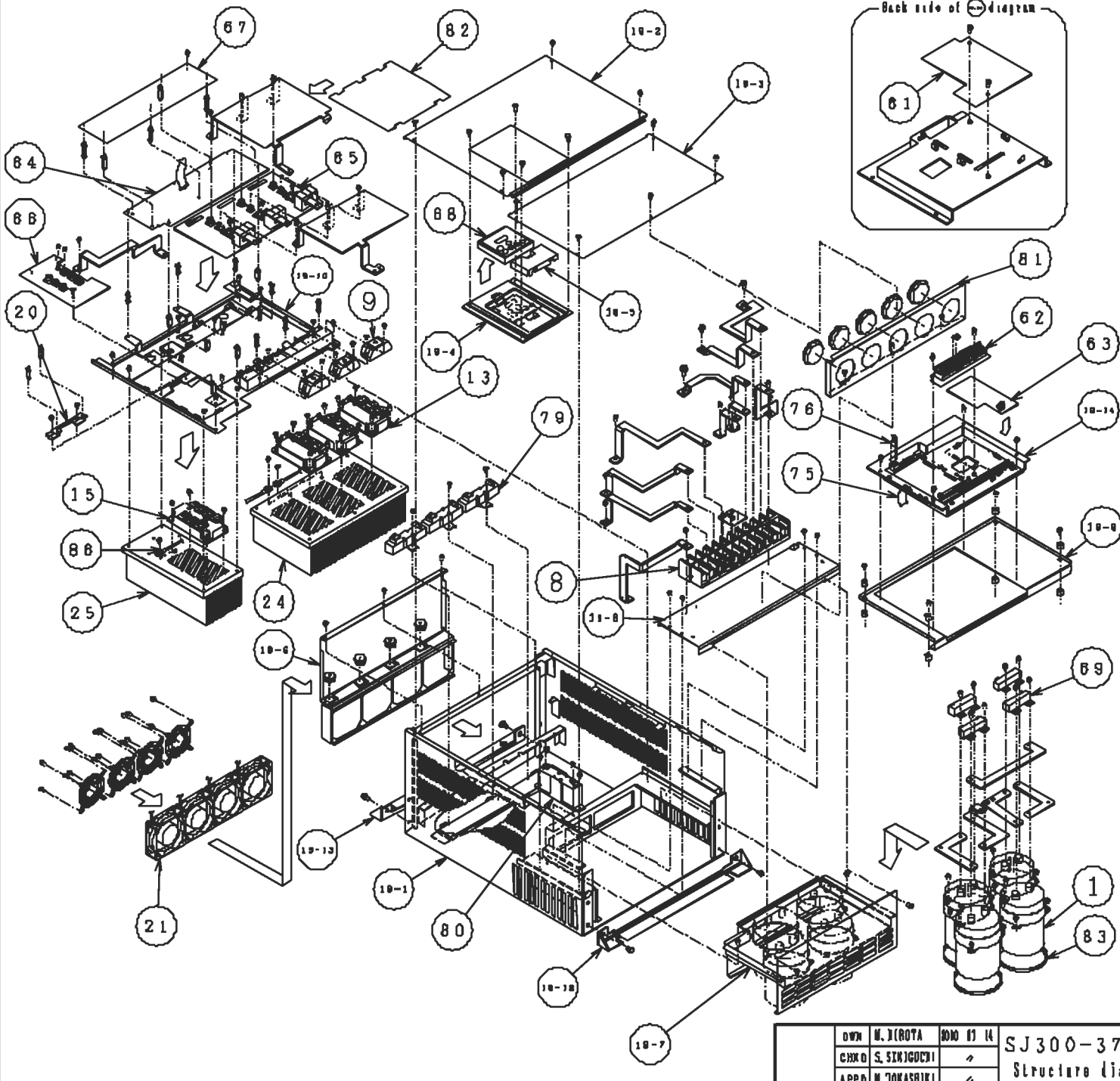
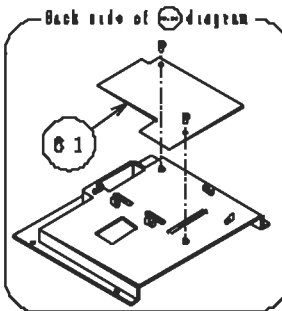

No	Abbreviation	Name of parts	Quantity per 1 unit
1	CB	DC bus capacitor	4
7	HLK	Main circuit terminals	1
9	INS	Insulation terminal	3
13	TRB	IGBT module	3
15	DM	Diode module	1
19-1	CS	Main body case	1
19-1	CV	Front cover	1
19-1	CV	Terminals cover	1
19-1	CV	Digital operator attachment board	1
19-1	CV	Spacer cover	1
19-1	FUDO	Cooling fan attachment board	1
19-1	PL	DC bus capacitor attachment block	1
19-1	RED	Terminal attachment board	1
19-1	PL	Shielding board	1
19-1	PL	Parts attachment board	1
19-1	PL	Attachment board	1
19-1	PL	Attachment board	1
19-1	PL	Control PCB attachment board	1
20	PL	DM PCB attachment board	1
21	FAN	Cooling fan	4
24	PIN	Heat sink	1
25	FIN	Heat sink	1
61	P/L	Logic PCB	1
62	P/SUB	Control circuit terminals PCB	1
63	PCB	ROTO PCB	1
64	PCB	Main PCB	1
65	PCB	(CT/snubber PCB)	1
68	PCB	DM PCB	1
67	PCB	Power source PCB	1
68	PANEL	Digital operator	1
69	RB	Balance resistor	4
75	WIRE	FFC	1
78	PLUG	Digital operator connection plug	1
78	R1-R3	Snubber resistor	3
80	RS	Current-limiting resistor	1
81	PL	Wiring blind cover	1
82	PL	Busbar insulation board	1
83	SPACER	Spacer	4
86	TRMI	Thermistor	3

OWN M. YAMOTA
 CHKD S. SAKAGUCHI
 APPD M. YOKASAKI

SJ300-370HF
 Structure Diagram

Hitachi, Ltd.
 Tokyo, Japan

WARASHINO WORKS INC. NO.
 324 3T823596

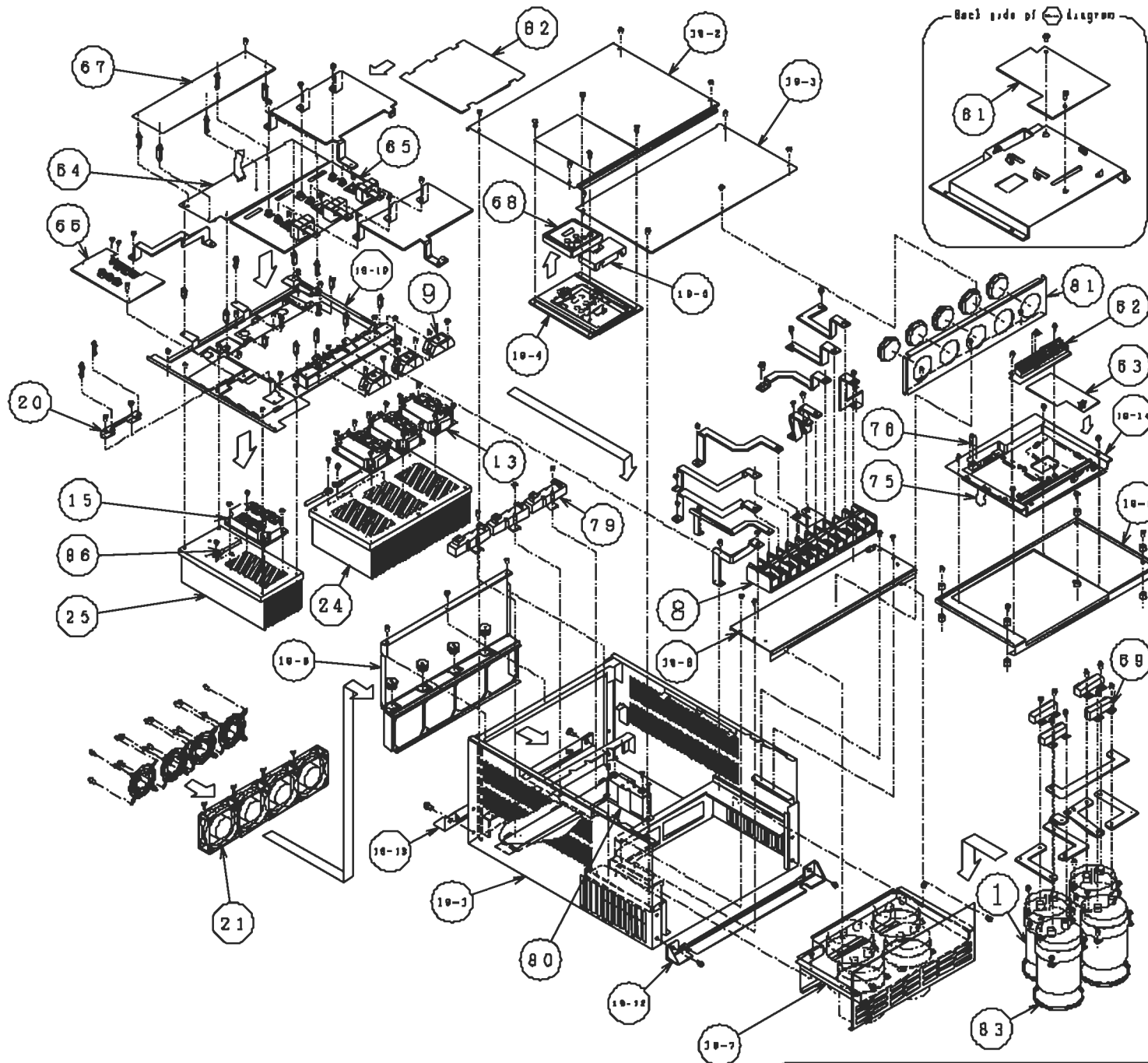

No.	Abbreviation	Name of parts	Quantity for 1 unit
1	CB	DC bus capacitor	4
8	T. BLK	Main circuit terminals	1
9	INS	Insulation terminal	3
13	TRS	IGBT module	3
15	DM	Diode module	1
18-1	CS	Main body case	1
18-2	CV	Front cover	1
18-3	CV	Terminals cover	1
18-4	CV	Digital operator attachment board	1
18-5	CV	Spacer cover	1
18-6	FUDO	Cooling fan attachment board	1
18-7	PL	DC bus capacitor attachment block	1
18-8	BED	Terminal attachment board	1
18-9	PL	Shielding board	1
18-10	PL	Parts attachment board	1
18-11	PL	Attachment board	1
18-12	PL	Attachment board	1
18-13	PL	Control PCB attachment board	1
18-14	PL	DM PCB attachment board	1
20	PL	DM PCB attachment board	1
21	PAN	Cooling fan	4
24	FIN	Heat sink	1
25	FIN	Heat sink	1
81	P/L	Logic PCB	1
82	P/SUB	Control circuit terminals PCB	1
83	PCB	ROTD PCB	1
84	PCB	Main PCB	1
85	PCB	{CT/snubber PCB}	1
86	PCB	DM PCB	1
87	PCB	Power source PCB	1
88	PANEL	Digital operator	1
89	RB	Balance resistor	4
75	WIRE	FFC	1
78	PLUG	Digital operator connection plug	1
79	R1-R3	Snubber resistor	3
80	RS	Current-limiting resistor	1
81	PL	Wiring blind cover	1
82	PL	Busbar insulation board	1
83	SPACER	Spacer	4
86	TRM	Thermistor	3

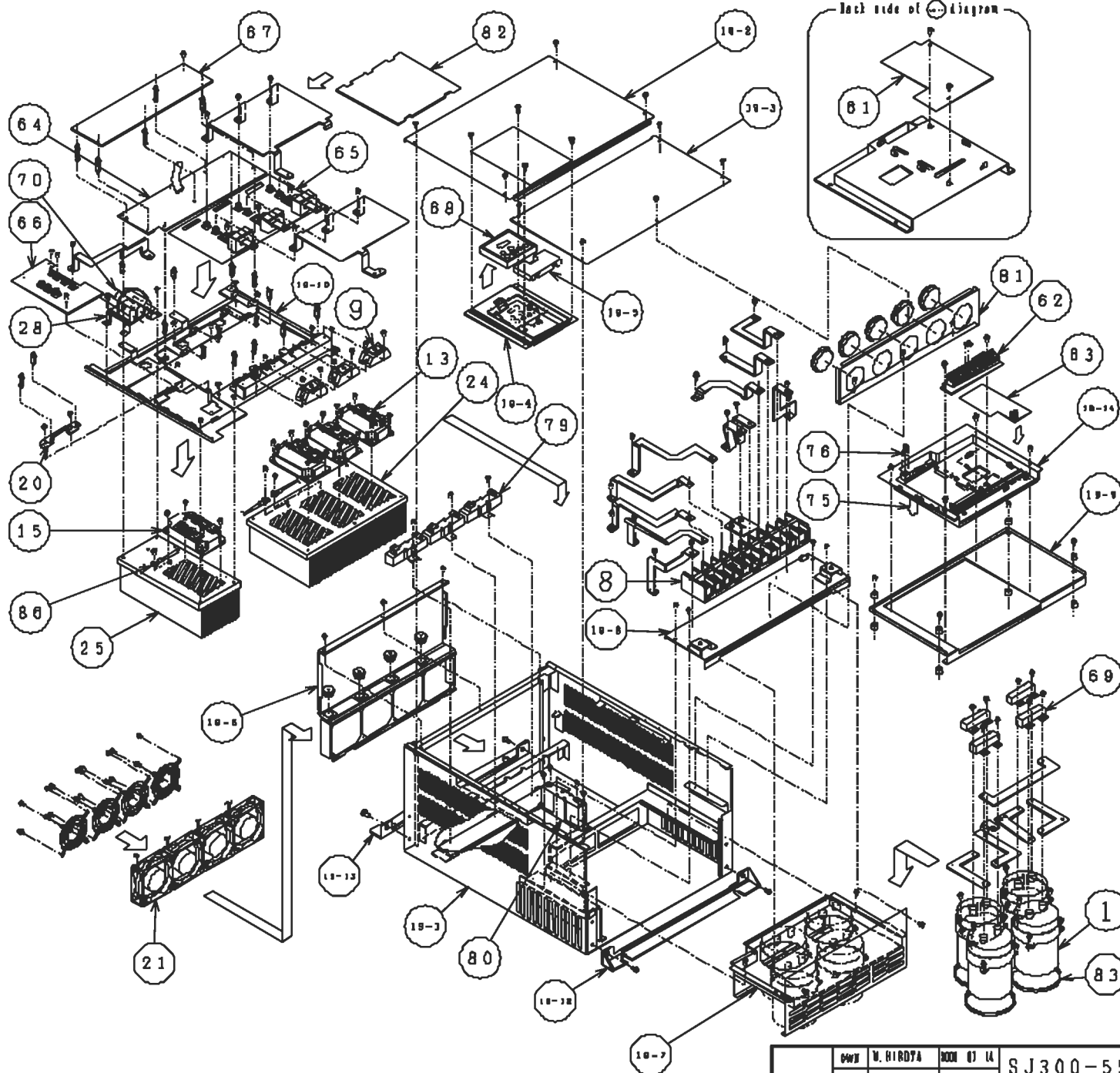

No.	Abbreviation	Name of parts	Quantity per 1 unit
1	CB	DC bus capacitor	4
8	T. BLK	Main circuit terminals	1
8	INS	Insulation terminal	3
13	TR5	IGBT module	3
15	DM	Diode module	1
19-1	CS	Main body case	1
19-2	CV	Front cover	1
19-3	CV	Terminals cover	1
19-4	CV	Digital operator attachment board	1
19-5	CV	Spacer cover	1
19-6	FUOD	Cooling fan attachment board	1
19-7	PL	IG bus capacitor attachment block	1
19-8	BED	Terminal attachment board	1
19-9	PL	Shielding board	1
19-10	PL	Parts attachment board	1
19-11	PL	Attachment board	1
19-12	PL	Attachment board	1
19-13	PL	Control PCB attachment board	1
20	PL	DM PCB attachment board	1
21	FAN	Cooling fan	4
24	FIN	Heat sink	1
25	FIN	Heat sink	1
28	PL	Rubber capacitor attachment board	1
61	P/L	Logic PCB	1
62	P/SUB	Control circuit terminals PCB	1
63	PCB	ROTO PCB	1
64	PCB	Main PCB	1
65	PCB	(CT/snubber PCB)	1
66	PCB	DM PCB	1
67	PCB	Power source PCB	1
68	PANEL	Digital operator	1
68	RB	Balance resistor	4
70	CI-C3	Snubber capacitor	3
75	WIRE	FFC	1
76	PLUG	Digital operator connection plug	1
78	R1-R3	Snubber resistor	3
80	RS	Current-limiting resistor	1
81	PL	Wiring blind cover	1
82	PL	Busbar insulation board	1
83	SPACER	Spacer	4
86	TRM1	Thermistor	3

品番	部品名称	部品名	1台分 使用数量
1	CB	DC bus capacitor	8
8	T. BLK	Main circuit terminals	1
13	TR3	IGBT module	6
14	THY	Thyristor module	1
15	DM	Diode module	3
19-1	CS	Main body case	1
19-2	CV	Front cover	1
19-3	CV	Terminals cover	1
19-4	CV	Digital operator attachment board	1
19-5	CV	Spacer cover	1
19-6	FUDO	Cooling fan attachment board	1
19-7	PL	DC bus capacitor attachment block	1
19-8	BED	Terminal attachment board	1
19-9	PL	Shielding board	1
19-10	PL	Parts attachment board	1
19-11	PL	Attachment board	1
19-12	PL	Attachment board	1
19-13	PL	Control PCB attachment board	1
21	FAN	Cooling fan	2
24	FIN	Heat sink	1
27	PL	Parts attachment board	1
60	P/SUB	Driver PCB	6
61	P/L	Logic PCB	1
62	P/SUB	Control circuit terminals PCB	1
63	PCB	ROTD PCB	1
64	PCB	GA PCB	1
65	PCB	Main PCB	1
66	PCB	DM PCB	1
67	PCB	Power source PCB	1
68	PANEL	Digital operator	1
69	RB	Balance resistor	8
75	WIRE	FEC	1
76	PLUG	Digital operator connection plug	1
79	R1~R6	Snubber resistor	6
80	RS	Current-limiting resistor	1
82	PL	Busbar insulation board	1
83	SPACER	Spacer	8
88	TRM1	Thermistor	5

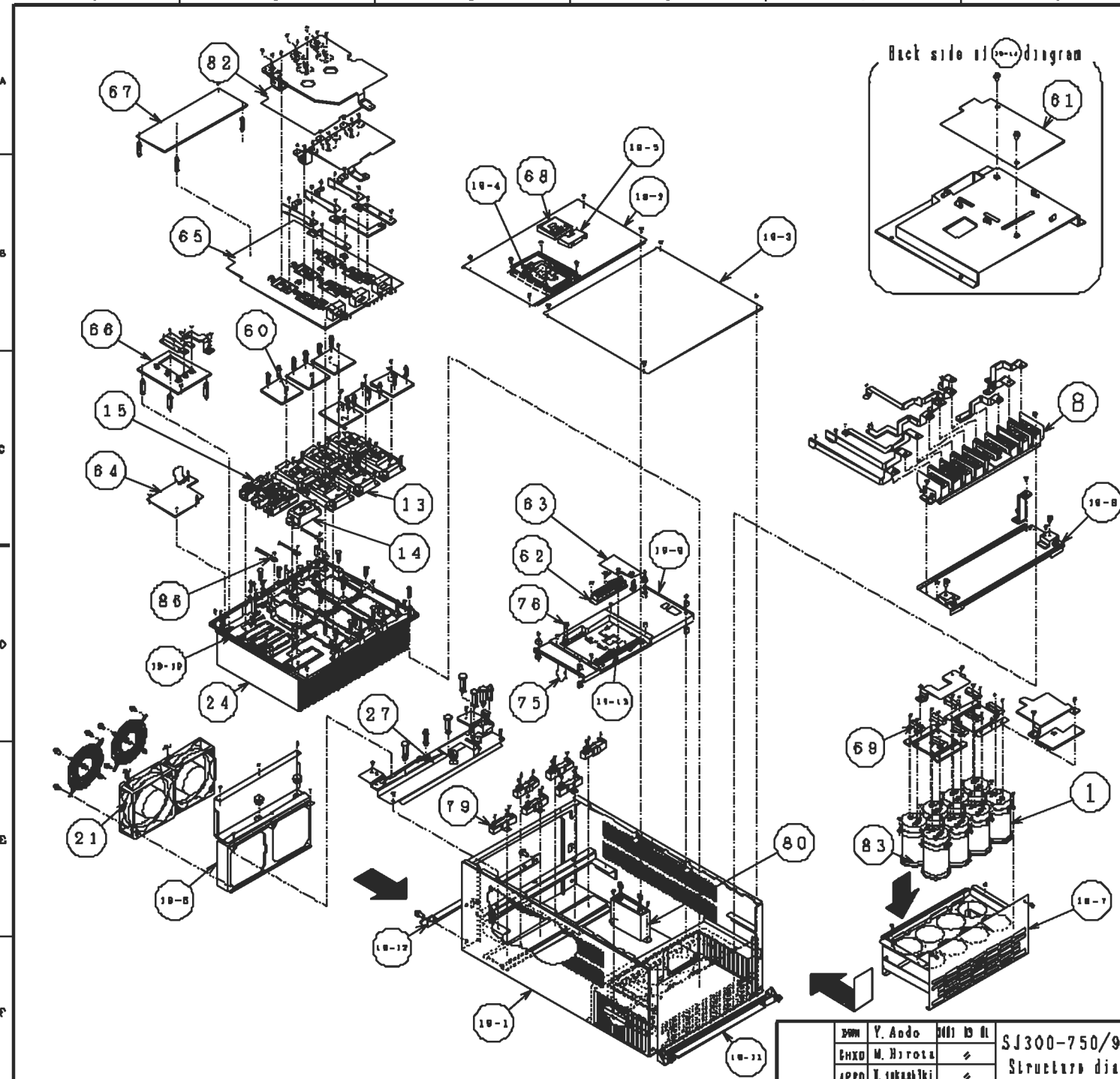
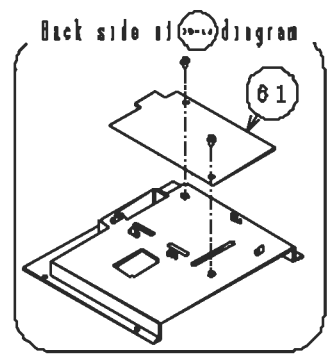

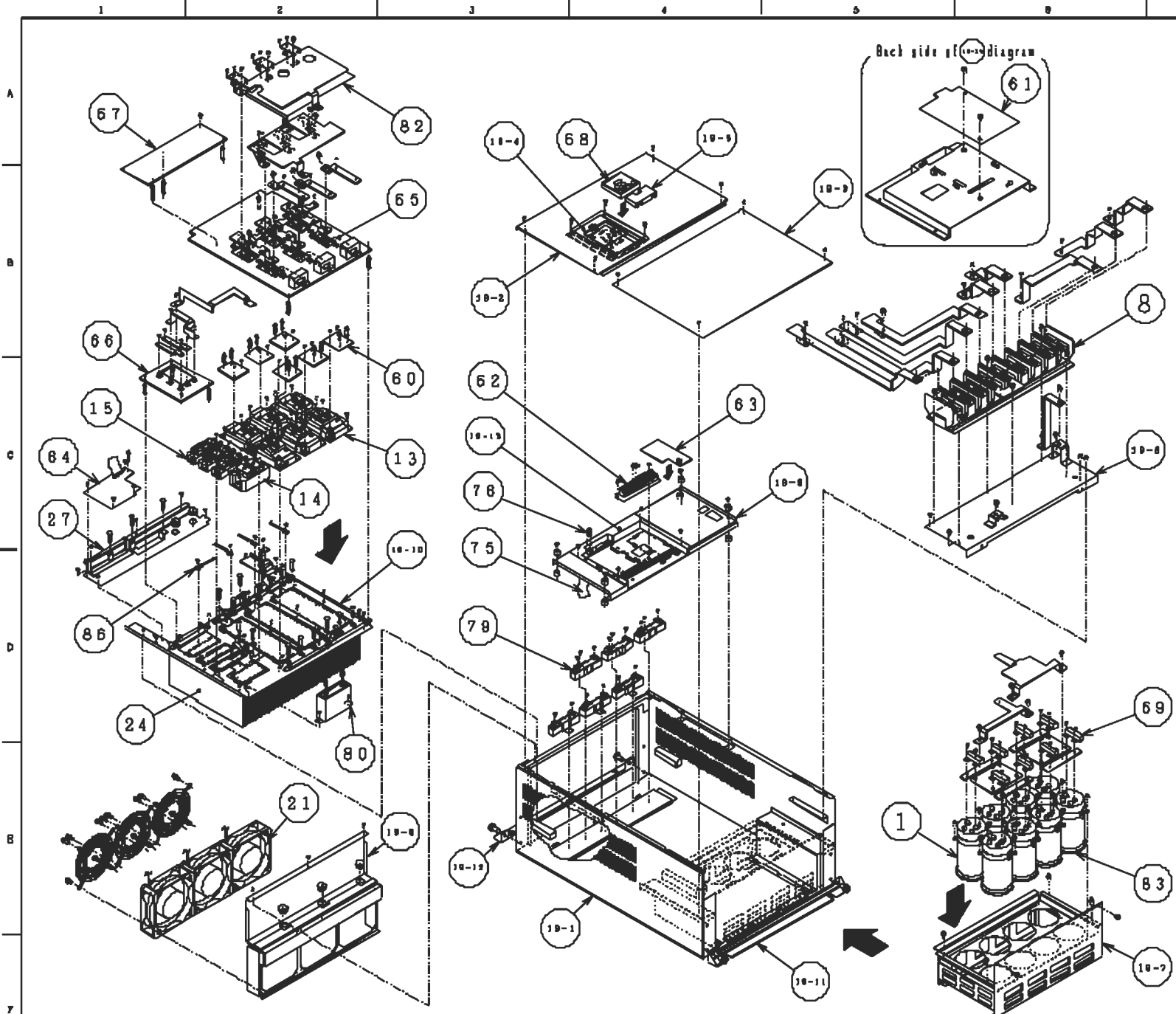

品番	部品名称	部品名	1台分 使用数量
1	CB	DC bus capacitor	8
8	7. BLK	Main circuit terminals	1
13	TR5	IGBT module	6
14	THY	Thyristor module	1
15	DM	Diode module	3
18-1	CS	Main body case	1
18-2	CV	Front cover	1
18-3	CV	Terminals cover	1
18-4	CV	Digital operator attachment board	1
18-5	CV	Spacer cover	1
18-6	FUDO	Cooling fan attachment board	1
18-7	PL	DC bus capacitor attachment block	1
18-8	BBB	Terminal attachment board	1
18-9	PL	Shielding board	1
18-10	PL	Parts attachment board	1
18-11	PL	Attachment board	1
18-12	PL	Attachment board	1
18-13	PL	Control PCB attachment board	1
21	PAN	Cooling fan	3
24	FIN	Heat sink	1
27	PL	Parts attachment board	1
60	P/SUB	Driver PCB	6
61	P/L	Logic PCB	1
62	P/SUB	Control circuit terminals PCB	1
63	PCB	ROTO PCB	1
64	PCB	GA PCB	1
65	PCB	Main PCB	1
66	PCB	DM PCB	1
67	PCB	Power source PCB	1
68	PANEL	Digital operator	1
69	RB	Balance resistor	8
75	WIRE	FEC	1
76	PLUG	Digital operator connection plug	1
79	R1-R8	Snubber resistor	6
80	RS	Current-limiting resistor	1
82	PL	Busbar insulation board	1
83	SPACER	Spacer	8
88	TRM	Thermistor	5

DEV	Y. Ando	CHK	H. H.	SJ300-1100/1320HP Structure diagram
ENGR	M. Hirota	APP	M. Takahashi	
APP	M. Takahashi			

Hitachi, Ltd.
Tokyo Japan
MARIKAWA WORKS Bldg. 4D,
324 3T 825274

SJ300/L300P Series SPARE PARTS LIST

No.	Parts No.	Drawing No.	Description	Remarks	Applied Model		Qty/Unit
					SJ300	L300P	
1	255023	3T017245-1	DC Bus Capacitor	1500uF	150LFU,LFE,HFU,HFE	185LFU,LFE,HFU,HFE	4
1	255024	3T017245-2	DC Bus Capacitor	1800uF	185LFU,LFE,HFU,HFE	220LFU,LFE,HFU,HFE	4
1	255025	3T017245-3	DC Bus Capacitor	2200uF	220LFU,LFE,HFU,HFE	300LFU,LFE,HFU,HFE	4
1	255026	3T017997-1	DC Bus Capacitor	3300uF	300LFU,LFE,HFU,HFE	370LFU,LFE,HFU,HFE	4
1	255027	3T017997-2	DC Bus Capacitor	3900uF	370LFU,LFE,HFU,HFE	450LFU,LFE,HFU,HFE	4
1	255028	3T017997-3	DC Bus Capacitor	4700uF	450LFU,LFE,HFU,HFE	550LFU,LFE,HFU,HFE	4
1	255029	3T017997-4	DC Bus Capacitor	5600uF	550HFU,HFE	750HFU,HFE	4
1	255030	3T017997-6	DC Bus Capacitor	5600uF	550LFU,LFE	750LFU	4
1	254065	3T017997-10	DC Bus Capacitor	3300uF	750HFU,HFE	900HFU,HFE	8
1	254066	3T017997-11	DC Bus Capacitor	3900uF	800HFU,HFE	1100HFU,HFE	8
1	254068	3T017997-8	DC Bus Capacitor	4700uF	1100HFU,HFE	1320HFU,HFE	8
1	254069	3T017997-9	DC Bus Capacitor	5600uF	1320HFU,HFE		8
8	255067	3T011307-2	Main Circuit Terminals	M6	150,185LFU,LFE 150-220HFU,HFE	185LFU,LFE 185-300HFU,HFE	1
8	255063	3T016823-1	Main Circuit Terminals	M8	220LFU,LFE	220,300LFU,LFE	1
8	255062	3T011307-8	Main Circuit Terminals	M6	300,370HFU,HFE	370HFU,HFE	1
8	255064	3T016823-4	Main Circuit Terminals	M8	300,370LFU,LFE, 450,550HFU,HFE	370LFU,LFE 450-750HFU,HFE	1
8	255065	3T018306-1	Main Circuit Terminals	M10	450LFU,LFE 750,900HFU,HFE	450-750LFU,LFE 900,1100HFU,HFE	1
8	255066	3T018716-1	Main Circuit Terminals	M10	550LFU,LFE 1100,1320HFU,HFE	1320HFU,HFE	1
13	255042	NCM150TU1-2F	IGBT Module	150A/600V	150,185LFU,LFE	185,220LFU,LFE	1
13	255043	NCM200TU1-2F	IGBT Module	200A/600V	220LFU,LFE	300LFU,LFE	1
13	255044	N2MBI300S-06	IGBT Module	300A/600V	300LFU,LFE	370LFU,LFE	3
13	255045	NCM300DU1-2F	IGBT Module	300A/600V	370LFU,LFE	450LFU,LFE	3
13	255046	NCM400DU1-2F	IGBT Module	400A/600V	450LFU,LFE	550LFU,LFE	3
13	255047	NCM600HU1-2F	IGBT Module	600A/600V	550LFU,LFE	750LFU	6
13	255048	NCM75TU24- F	IGBT Module	75A/1200V	150-185HFU,HFE	185-220HFU,HFE	1
13	255049	NCM100TU24- F	IGBT Module	100A/1200V	220HFU,HFE	300HFU,HFE	1
13	255050	N2MBI150C-12	IGBT Module	150A/1200V	300HFU,HFE	370HFU,HFE	3
13	255051	NCM150DU2-4F	IGBT Module	150A/1200V	370HFU,HFE	450HFU,HFE	3

No.	Parts No.	Drawing No.	Description	Remarks	Applied Model		Qty/Unit
					SJ300	L300P	
13	255052	NCM200DU2-4F	IGBT Module	200A/1200V	450HFU,HFE	550HFU,HFE	3
13	255053	NCM300DU2-4F	IGBT Module	300A/1200V	550HFU,HFE	750HFU,HFE	3
13	254070	NMBN400GR-12	IGBT Module	400A/1200V	750,900HFU,HFE	900,1320HFU,HFE	6
13	254071	NMBN600GR-12	IGBT Module	600A/1200V	1100,1320HFU,HFE	1320HFU,HFE	6
14	255040	NPHT2508	Thyristor Module	250A/800V	370,450LFU,LFE	450,550LFU,LFE	1
14	255041	NPHT4008	Thyristor Module	400A/800V	550LFU,LFE	750LFU	1
14	254077	NPHT25016	Thyristor Module	250A/1600V	750,900HFU,HFE	900,1100HFU,HFE	1
14	255177	NPHT40016	Thyristor Module	400A/1600V	1100,1320HFU,HFE	1320HFU,HFE	1
15	255031	NPGH1008A- M	Diode Module	100A/800V	150LFU,LFE	185LFU,LFE	1
15	255033	NPGH1508A- M	Diode Module	150A/800V	185,220LFU,LFE	220LFU,LFE	1
15	255036	NPGH2008A-M	Diode Module	200A/800V	300LFU,LFE	300,370LFU,LFE	1
15	255038	NPD1008AC	Diode Module	100A/800V	370,450LFU,LFE	450,550LFU,LFE	3
15	255039	NPD1508	Diode Module	150A/800V	550LFU,LFE	750LFU	3
15	255032	NPGH5016A-M	Diode Module	50A/1600V	150HFU,HFE	185HFU,LFE	1
15	255034	NPGH7516A-M	Diode Module	75A/1600V	185,220HFU,HFE	220,300HFU,HFE	1
15	255035	NPGH10016-AM	Diode Module	100A/1600V	300HFU,HFE	370HFU,HFE	1
15	255037	NPGH20016-AM	Diode Module	200A/1600V	370,450,550HFU,HFE	450,550,750HFU,HFE	1
15	254084	NPD10016	Diode Module	100A/1600V	750,900HFU,HFE	900,1100HFU,HFE	3
15	254086	NPD15116	Diode Module	150A/1600V	1100,1320HFU,HFE	1320HFU,HFE	3
19-2	254099	2T004540-1	Front Cover		004-055LFU,LFE 007-055HFU,HFE		1
19-2	254101	2T004549-1	Front Cover		075-110LFU,LFE 075-110HFU,HFE		1
19-2	254103	2T004568-1	Front Cover		150-220LFU,LFE 150-220HFU,HFE		1
19-2	254230	2T004549-2	Front Cover			110-150LFU,LFE 110-150HFU,HFE	1
19-2	254251	2T004568-2	Front Cover			185-300LFU,LFE 185-300HFU,HFE	1
19-2	254103	2T004568-1	Front Cover		150-220LFU,LFE 150-220HFU,HFE		1
19-2	254230	2T004549-2	Front Cover			110-150LFU,LFE 110-150HFU,HFE	1
19-2	254251	2T004568-2	Front Cover			185-300LFU,LFE 185-300HFU,HFE	1
19-3	254373	4T016893-1A	Terminals Cover		004-055LFU,LFE 007-055HFU,HFE		1

SJ300/L300P Series SPARE PARTS LIST

No.	Parts No.	Drawing No.	Description	Remarks	Applied Model		Qty/Unit
					SJ300	L300P	
19-3	254501	4T016894-1A	Terminals Cover		075-110LFU,LFE 075-110HFU,HFE		1
19-3	254502	4T016895-1A	Terminals Cover		150-220LFU,LFE 150-220HFU,HFE		1
19-3	254503	4T016894-1B	Terminals Cover			110-150LFU,LFE 110-150HFU,HFE	1
19-3	254504	4T016895-1B	Terminals Cover			185-300LFU,LFE 185-300HFU,HFE	1
19-5	254814	3T016788-1	Spacer Cover		004-550LFU,LFE 007-1320HFU,HFE		1
19-5	254815	3T016788-2	Spacer Cover			110-750LFU,LFE 110-1320HFU,HFE	1
19-6	254979	3T016596-1	Cooling Fan Attachment Board		004-055LFU,LFE 007-055HFU,HFE		1
19-6	254980	2T004544-1	Cooling Fan Attachment Board		075-110LFU,LFE 075-110HFU,HFE		1
19-6	254986	2T004566-1	Cooling Fan Attachment Board		150-220LFU,LFE 150-220HFU,HFE		1
19-6	254990	2T004544-2	Cooling Fan Attachment Board			110-150LFU,LFE 150HFU,HFE	110- 1
19-6	254991	2T004566-2	Cooling Fan Attachment Board			185-300LFU,LFE 185-300HFU,HFE	1
19-7	254992	3T016597-3	DC Bus Capacitor Attachment Block		004-007LFU,LFE 007HFU,HFE		1
19-7	255006	3T016597-1	DC Bus Capacitor Attachment Block		015-055LFU,LFE 015-055HFU,HFE		1
19-7	255119	2T004545-1	DC Bus Capacitor Attachment Block		075-110LFU,LFE 110HFU,HFE	075-	1
19-7	255122	2T004565-1	DC Bus Capacitor Attachment Block		150-220LFU,LFE 150-220HFU,HFE		1
19-7	255123	2T004545-2	DC Bus Capacitor Attachment Block			110-150LFU,LFE 110-150HFU,HFE	1
19-7	255124	2T004565-2	DC Bus Capacitor Attachment Block			185-300LFU,LFE 185-300HFU,HFE	1
19-11	254808	1T001890-1	Main Body Cover		004-055LFU,LFE 007-055HFU,HFE		1
19-11	254810	1T001894-1	Main Body Cover		075-110LFU,LFE 110HFU,HFE	075-	1
19-11	254811	1T001906-1	Main Body Cover		150-220LFU,LFE 220HFU,HFE	150-	1
19-11	254812	1T001894-2	Main Body Cover			110-150LFU,LFE 110-150HFU,HFE	1
19-11	254813	1T001906-2	Main Body Cover			185-300LFU,LFE 300HFU,HFE	185- 1
21	255020	3T016890-1	Cooling Fan (MMF-06F24ES-RN1)	60mm DC24V	004-055LFU,LFE 007-055HFU,HFE		1
21	255021	3T016989-1	Cooling Fan (MMF-08D24ES-RN2)	80mm DC24V	075-220LFU,LFE,HFU,HFE	110-300LFU,LFE,HFU,HFE	2
21	255021	3T016989-1	Cooling Fan (MMF-08D24ES-RN2)	80mm DC24V	300LFU,LFE,HFU,HFE	370LFU,LFE,HFU,HFE	3
21	255021	3T016989-1	Cooling Fan (MMF-08D24ES-RN2)	80mm DC24V	370,450LFU,LFE 370-550HFU,HFE	450,550LFU,LFE,HFU,HFE 750HFU,HFE	4
21	255022	3T018969-1	Cooling Fan (MMF-12D24DS-RN5)	120mm DC24V	550LFU,LFE	750LFU	3
21	254515	3T019914-1	Cooling Fan (109P1324S103)	127mm DC24V	750,900HFU,HFE	900,1100HFU,HFE	2

No.	Parts No.	Drawing No.	Description	Remarks	Applied Model		Qty/Unit
					SJ300	L300P	
21	254515	3T019914-1	Cooling Fan (109P1324S103)	127mm DC24V	1100,1320HFU,HFE	1320HFU,HFE	3
60	254516	SJ3 CB004L	DC Bus capacitor PCB		004LFU,LFE		1
60	254517	SJ3 CB007L	DC Bus capacitor PCB		007LFU,LFE		1
60	255008	SJ3 CB015L	DC Bus capacitor PCB		015LFU,LFE		1
60	255009	SJ3 CB022L	DC Bus capacitor PCB		022LFU,LFE		1
60	255010	SJ3 CB037L	DC Bus capacitor PCB		037LFU,LFE		1
60	255011	SJ3 CB055L	DC Bus capacitor PCB		055LFU,LFE		1
60	255016	SJ3 CB075L	DC Bus capacitor PCB		075LFU,LFE	110LFU,LFE	1
60	255017	SJ3 CB110L	DC Bus capacitor PCB		110LFU,LFE	150LFU,LFE	1
60	254518	SJ3 CB007H	DC Bus capacitor PCB		007HFU,HFE		1
60	255012	SJ3 CB015H	DC Bus capacitor PCB		015HFU,HFE		1
60	255013	SJ3 CB022H	DC Bus capacitor PCB		022HFU,HFE		1
60	255014	SJ3 CB037H	DC Bus capacitor PCB		037HFU,HFE		1
60	255015	SJ3 CB055H	DC Bus capacitor PCB		055HFU,HFE		1
60	255018	SJ3 CB075H	DC Bus capacitor PCB		075HFU,HFE	110HFU,HFE	1
60	255019	SJ3 CB110H	DC Bus capacitor PCB		110HFU,HFE	150HFU,HFE	1
61	254937	SJ300P-L	Logic PCB		004-550LFU,LFE 007-550HFU,HFE	110-750LFU,LFE 110-750HFU,HFE	1
61	255146	SJ300P-L	Logic PCB		750-1320HFU,HFE	900-1320HFU,HFE	1
62	254049	SJ300TM	Control circuit Terminals PCB		004-550LFU,LFE 007-1320HFU,HFE		1
62	255007	L300PTM	Control circuit Terminals PCB			110-750LFU,LFE 110-1320HFU,HFE	1
63	254040	SJ3 D030-55L	ROTO PCB		300-550LFU,LFE	370-750LFU,LFE	1
63	254043	SJ3 D030-55H	ROTO PCB		300-1320HFU,HFE	370-1320HFU,HFE	1
64	254519	SJ3 B007L	Main PCB with Main body case		004LFU,LFE		1
64	254520	SJ3 B004L	Main PCB with Main body case		007LFU,LFE		1
64	255099	SJ3 B015L	Main PCB with Main body case		015LFU,LFE		1
64	255100	SJ3 B022L	Main PCB with Main body case		022LFU,LFE		1
64	255101	SJ3 B037L	Main PCB with Main body case		037LFU,LFE		1
64	255102	SJ3 B055L	Main PCB with Main body case		055LFU,LFE		1

SJ300/L300P Series SPARE PARTS LIST

No.	Parts No.	Drawing No.	Description	Remarks	Applied Model		Qty/Unit
					SJ300	L300P	
64	254985	SJ3 B075L	Main PCB with Main body case		075LFU,LFE		1
64	255103	SJ3 B110L	Main PCB with Main body case		110FU,LFE		1
64	255104	SJ3 B150L	Main PCB		150LFU,LFE		1
64	255105	SJ3 B185L	Main PCB		185LFU,LFE		1
64	255106	SJ3 B220L	Main PCB		220LFU,LFE		1
64	255110	SJ3 B300L	Main PCB		300LFU,LFE	370LFU,LFE	1
64	255098	SJ3 B370L	Main PCB		370LFU,LFE	450LFU,LFE	1
64	255112	SJ3 B450L	Main PCB		450LFU,LFE	550LFU,LFE	1
64	255116	SJ3 B650L	Main PCB		550LFU,LFE	750LFU	1
64	254521	SJ3 B007H	Main PCB with Main body case		007HFU,HFE		1
64	254981	SJ3 B015H	Main PCB with Main body case		015HFU,HFE		1
64	254982	SJ3 B022H	Main PCB with Main body case		022HFU,HFE		1
64	254983	SJ3 B037H	Main PCB with Main body case		037HFU,HFE		1
64	254984	SJ3 B055H	Main PCB with Main body case		055HFU,HFE		1
64	254987	SJ3 B075H	Main PCB with Main body case		075HFU,HFE		1
64	254988	SJ3 B110H	Main PCB with Main body case		110HFU,HFE		1
64	255107	SJ3 B150H	Main PCB		150HFU,HFE		1
64	255108	SJ3 B185H	Main PCB		185HFU,HFE		1
64	255109	SJ3 B220H	Main PCB		220HFU,HFE		1
64	255111	SJ3 B300H	Main PCB		300HFU,HFE	370HFU,HFE	1
64	255113	SJ3 B370H	Main PCB		370HFU,HFE	450HFU,HFE	1
64	255114	SJ3 B450H	Main PCB		450HFU,HFE	550HFU,HFE	1
64	255115	SJ3 B550H	Main PCB		550HFU,HFE	750HFU,HFE	1
64	254522	SJ3 B750H	Main PCB		750HFU,HFE		1
64	254523	SJ3 B900H	Main PCB		900HFU,HFE		1
64	254524	SJ3 B1100H	Main PCB		1100HFU,HFE		1
64	254525	SJ3 B1320H	Main PCB		1320HFU,HFE		1
64	254526	L3P B900H	Main PCB			900HFU,HFE	1

No.	Parts No.	Drawing No.	Description	Remarks	Applied Model		Qty/Unit
					SJ300	L300P	
64	254527	L3P 1100H	Main PCB			1100HFU,HFE	1
64	254528	L3P 1320H	Main PCB			1320HFU,HFE	1
64	255117	L3P B110L	Main PCB with Main body case			110LFU,LFE	1
64	255118	L3P B150L	Main PCB with Main body case			150LFU,LFE	1
64	254995	L3P B185L	Main PCB			185LFU,LFE	1
64	254996	L3P B220L	Main PCB			220LFU,LFE	1
64	254997	L3P B300L	Main PCB			300LFU,LFE	1
64	254993	L3P B110H	Main PCB with Main body case			110HFU,HFE	1
64	254994	L3P B150H	Main PCB with Main body case			150HFU,HFE	1
64	254998	L3P B185H	Main PCB			185HFU,HFE	1
64	254999	L3P B220H	Main PCB			220HFU,HFE	1
64	255000	L3P B300H	Main PCB			300HFU,HFE	1
65	255054	SJ3 S300L	CT/Snubber PCB		300LFU,LFE		1
65	255056	SJ3 S370L	CT/Snubber PCB		370LFU,LFE		1
65	255057	SJ3 S450L	CT/Snubber PCB		450LFU,LFE		1
65	255058	SJ3 CT550L	CT PCB		550LFU,LFE		1
65	255055	SJ3 S300H	CT/Snubber PCB		300HFU,HFE		1
65	255059	SJ3 S370H	CT/Snubber PCB		370HFU,HFE		1
65	255060	SJ3 S450H	CT/Snubber PCB		450HFU,HFE		1
65	255061	SJ3 S550H	CT/Snubber PCB		550HFU,HFE		1
65	254529	L3P S370L	CT/Snubber PCB			370LFU,LFE	1
65	254530	L3P S450L	CT/Snubber PCB			450LFU,LFE	1
65	254534	L3P S550L	CT/Snubber PCB			550LFU,LFE	1
65	254536	L3P CT750L	CT PCB			750LFU	1
65	254531	L3P S370H	CT/Snubber PCB			370HFU,HFE	1
65	254532	L3P S450H	CT/Snubber PCB			450HFU,HFE	1
65	254533	L3P S550H	CT/Snubber PCB			550HFU,HFE	1
65	254535	L3P S750H	CT/Snubber PCB			750HFU,HFE	1

SJ300/L300P Series SPARE PARTS LIST

No.	Parts No.	Drawing No.	Description	Remarks	Applied Model		Qty/Unit
					SJ300	L300P	
66	255084	SJ3 C15L	DM PCB		150LFU,LFE	185LFU,LFE	1
66	255085	SJ3 C18-30L	DM PCB		185-300LFU,LFE	220-370LFU,LFE	1
66	255086	SJ3 C37-45L	DM PCB		370-450LFU,LFE	450-550LFU,LFE	1
66	255087	SJ3 C55-90L	DM PCB		550LFU,LFE	750LFU	1
66	255088	SJ3 C15-30H	DM PCB		150-300HFU,HFE	185-370HFU,HFE	1
66	255089	SJ3 C37-55H	DM PCB		370-550HFU,HFE	450-750HFU,HFE	1
66	254537	SJ3 C75-90H	DM PCB		750,900HFU,HFE	900,1100HFU,HFE	1
66	254538	SJ3 CX1-X6H	DM PCB		1100,1320HFU,HFE	1320HFU,HFE	1
67	255001	SJ3D15-22L	Power Source PCB		150-220LFU,LFE	185-300LFU,LFE	1
67	255003	SJ3D30-45L	Power Source PCB		300-450LFU,LFE	370-550LFU,LFE	1
67	255005	SJ3D55-75L	Power Source PCB		550LFU,LFE	750LFU	1
67	255002	SJ3D15-22H	Power Source PCB		150,220HFU,HFE	185-300HFU,HFE	1
67	255004	SJ3D30-55H	Power Source PCB		300-550HFU,HFE	370-750HFU,HFE	1
67	254539	SJ3 D75-X3H	Power Source PCB		750-1320HFU,HFE	900-1320HFU,HFE	1
68	OPE-S	OPE-S	Digital Operator		All models for EC-version		1
68	OPE-SR	OPE-SR	Digital Operator			All models for EC-version	1
68	OPE-SR	OPE-SR(E)	Digital Operator		All models for US-version	All models for US-version	1
69	254431	N4W563JB	Blance Resistor		150-220LFU,LFE,HFU,HFE	185-300LFU,LFE,HFU,HFE	4
69	254431	N4W563JB	Blance Resistor		750,900HFU,HFE	900,1100HFU,HFE	8
69	254432	N4W563JB6	Blance Resistor		300-550LFU,LFE	370-750LFU,LFE	2
69	254432	N4W563JB6	Blance Resistor		300-550HFU,HFE	370-750HFU,HFE	4
69	254432	N4W563JB6	Blance Resistor		1100,1320HFU,HFE	1320HFU,HFE	8
70	255074	4T015352-1	Snubber Capacitor		150-220LFU,LFE	185-300LFU,LFE	1
70	255075	4T015352-3	Snubber Capacitor		150-220HFU,HFE	185-300HFU,HFE	1
70	255080	3T018884-1	Snubber Capacitor	Cable Length 100mm	550LFU,LFE	750LFU	3
70	255147	4T016028-1	Snubber Capacitor	Cable Length 310mm 250mm	550HFU,HFE	750HFU,HFE	1
70	255148	4T016028-2	Snubber Capacitor	Cable Length 400mm 300mm	550HFU,HFE	750HFU,HFE	1
70	255149	4T016028-3	Snubber Capacitor	Cable Length 480mm 390mm	550HFU,HFE	750HFU,HFE	1

No.	Parts No.	Drawing No.	Description	Remarks	Applied Model		Qty/Unit
					SJ300	L300P	
71	255081	3T018886-1	Snubber Capacitor	Cable Length 100mm	550LFU,LFE	750LFU	3
72	255076	4T016022-1	Snubber Capacitor	Non cable	550LFU,LFE	750LFU	3
73	255077	4T016093-1	Snubber Capacitor	Cable Length 410mm	550LFU,LFE	750LFU	1
73	255078	4T016093-2	Snubber Capacitor	Cable Length 440mm	550LFU,LFE	750LFU	1
73	255079	4T016093-3	Snubber Capacitor	Cable Length 550mm	550LFU,LFE	750LFU	1
75	255082	4T014614- 1	FFC		004-220LFU,LFE 007-220HFU,HFE	110-300LFU,LFE,HFU,HFE	1
75	255083	4T014614- 2	FFC		300-550LFU,LFE 300-1320HFU,HFE	370-750LFU,LFE 370-1320HFU,HFE	1
76	255072	N55029881-0	Digital Operetor Connection Plug		004-550LFU,LFE 007-1320HFU,HFE	110-750LFU,LFE 110-1320HFU,HFE	1
79	253006	3T001303-16	Snubber Resistor		370,450LFU,LFE 550HFU,HFE	370-450,550LFU,LFE 450-750HFU,HFE	3
79	253006	3T001303-16	Snubber Resistor		550LFU,LFE 1320HFU,HFE	750-750LFU,LFE 900-1320HFU,HFE	6
80	255068	4T014572-3	Current Limiting Resistor		150-300LFU,LFE	185-370LFU,LFE	1
80	255070	3T011643-3	Current Limiting Resistor		370-550LFU,LFE	450-750LFU,LFE	1
80	255069	4T014572-3	Current Limiting Resistor		150-300HFU,HFE	185-370HFU,HFE	1
80	255071	3T011643-4	Current Limiting Resistor		370-550HFU,HFE	450-750HFU,HFE	1
80	254540	3T013573-17	Current Limiting Resistor		750,900HFU,HFE	900,1100HFU,HFE	1
80	254541	3T013573-18	Current Limiting Resistor		1100,1320HFU,HFE	1320HFU,HFE	1
81	254805	3T016852-2	Wiring Blind Cover		004-055LFU,LFE 007-055HFU,HFE		1
81	254806	3T016959-2	Wiring Blind Cover		075-110LFU,LFE 110HFU,HFE	075-110-150LFU,LFE 110-150HFU,HFE	1
81	254807	3T017422-2	Wiring Blind Cover		150-220LFU,LFE 150-220HFU,HFE	185-300LFU,LFE 185-300HFU,HFE	1
86	254795	4T016519-1	Thermistor		150-220LFU,LFE,HFU,HFE	185-300LFU,LFE,HFU,HFE	1
86	254796	4T016519-1	Thermistor		300LFU,LFE,HFU,HFE	370LFU,LFE,HFU,HFE	2
86	254797	4T016519-3	Thermistor		370-450LFU,LFE 370-550HFU,HFE	450-550LFU,LFE 450-750HFU,HFE	3
86	254796	4T016519-2	Thermistor		550LFU,LFE	750LFU,LFE	3
86	254796	4T016519-2	Thermistor		750-1320HFU,HFE	900-1320HFU,HFE	5
95	254798	SJ3 DR75-90H	Driver PCB		750,900HFU,HFE	900-1100HFU,HFE	6
95	254799	SJ3 DRX1-X3H	Driver PCB		1100,1320HFU,HFE	1320HFU,HFE	6
96	254800	SJ3 GA75-X3H	GA PCB		750-1320HFU,HFE	900-1320HFU,HFE	1

SJ300/L300P Series SPARE PARTS LIST

No.	Parts No.	Drawing No.	Description	Remarks	Applied Model		Qty/Unit
					SJ300	L300P	
	254801	NGMB25	Rubber Bush		004-055LFU,LFE 007-055HFU,HFE		3
	254802	NGMB31	Rubber Bush		075-110LFU,LFE,HFU,HFE	110-150LFU,LFE,HFU,HFE	3
	254803	NGMB39	Rubber Bush		150-220LFU,LFE,HFU,HFE	185-300LFU,LFE,HFU,HFE	4
	254802	NGMB31	Rubber Bush		300LFU,LFE, 370HFU,HFE	370LFU,LFE,HFU,HFE	5
	254804	NGMB51	Rubber Bush		370-450LFU,LFE 370-550HFU,HFE	450-550LFU,LFE,HFU,HFE	5
	254804	NGMB51	Rubber Bush		550LFU,LFE		6
	255125	N04RC1610-10	Ferrite core for J51		004-220LFU,LFE 007-220HFU,HFE	110-300LFU,LFE,HFU,HFE	1
	255126	N04FA4035-12	Ferrite core for FFC		004-220LFU,LFE 007-220HFU,HFE	110-300LFU,LFE,HFU,HFE	1
	255127	N4SR1352-5A	Ferrite core		150-220LFU,LFE,HFU,HFE	185-300LFU,LFE,HFU,HFE	1
	255128	N04SR2093-5A	Ferrite core		150-220LFU,LFE,HFU,HFE	185-300LFU,LFE,HFU,HFE	1
	255129	4T015702-1	Shielding finger (16 Block)		004-110LFU,LFE 007-110HFU,HFE	110-150LFU,LFE,HFU,HFE	1

No.	Parts No.	Drawing No.	Description	Remarks	Applied Model		Qty/Unit
					SJ300	L300P	
	255130	4T015702-2	Shielding finger (2 Block)		004-110LFU,LFE 007-110HFU,HFE	110-150LFU,LFE,HFU,HFE	2
	255131	4T015769-2	Shielding finger (32 Block)		150-220LFU,LFE,HFU,HFE	185-300LFU,LFE,HFU,HFE	2
	255132	4T015018-1	Wire for J51		All Models	All Models	1
	255133	4T015019-1	Wire for J61		All Models	All Models	1
	255134	2T004745-1	Front cover for sheet metal		300-550LFU,LFE 300-1320HFU,HFE		1
	255135	2T004745-2	Front cover for sheet metal			370-750LFU,LFE 370-1320HFU,HFE	1
	255136	1T002032-1	Logic PCB attachment board		300-550LFU,LFE 300-1320HFU,HFE		1
	255137	1T002032-2	Logic PCB attachment board			370-750LFU,LFE 370-1320HFU,HFE	1
	255150	4T015209-1	Insulated plate		004-055LFU,LFE 007-055HFU,HFE		1
	255151	4T015044-1	Insulated plate		075-110LFU,LFE,HFU,HFE	110-150LFU,LFE,HFU,HFE	1
	255152	N6208520030	FFC Connector		All Models	All Models	2

Rev.# 1 = Added MCU100TU24-F in item No.13

Rev.# 2 = Mentioned the parts number

Rev.# 3 = Modified some points (Blue color)

Rev.# 4 = Modified some points and added some items (Orange color)